

**CONNECTOR
 DESIGNATORS
 A-F-H-L-S
 ROTATABL
 COUPLING**

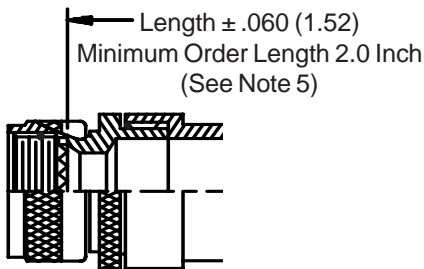

STYLE 2
 (STRAIGHT
 See Note 1)

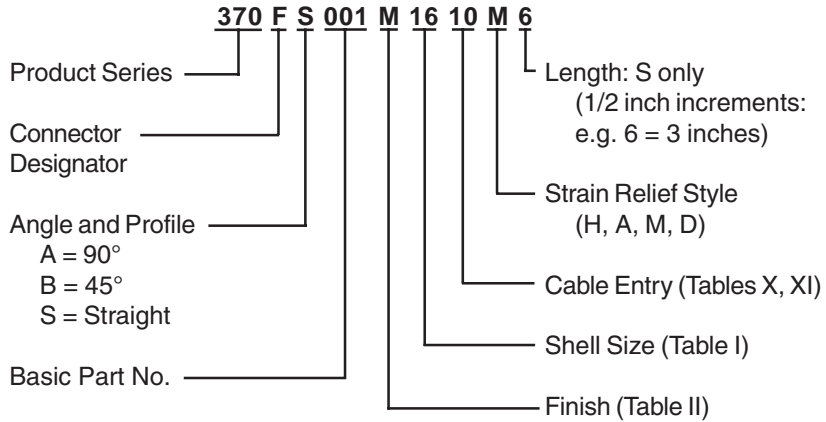
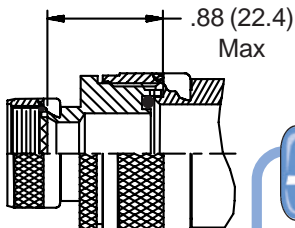
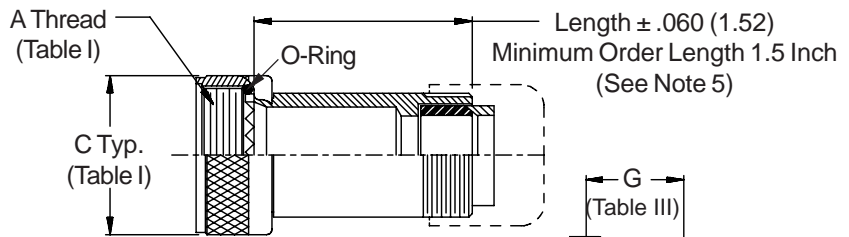

STYLE 2
 (45° & 90°
 See Note 1)

-445 Now Available with the "NESTOR"
 Glenair's Non-Detent, Spring-Loaded, Self-Locking Coupling.
 Add "-445" to Specify This AS85049 Style "N" Coupling Interface.

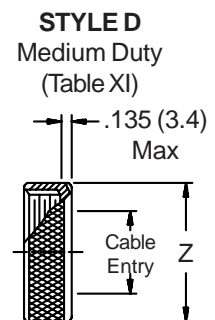
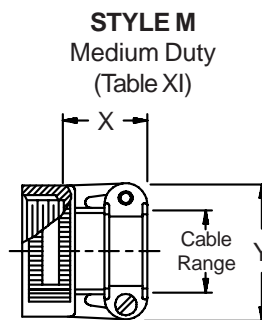
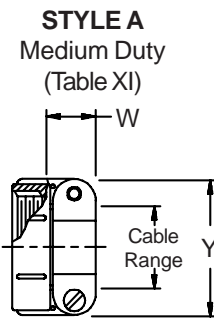
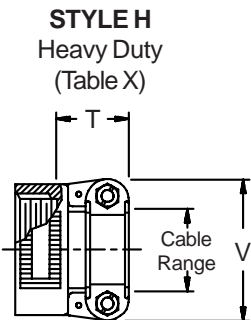
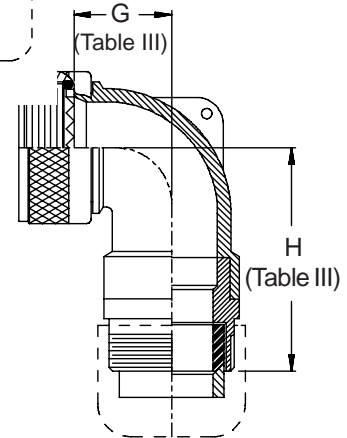
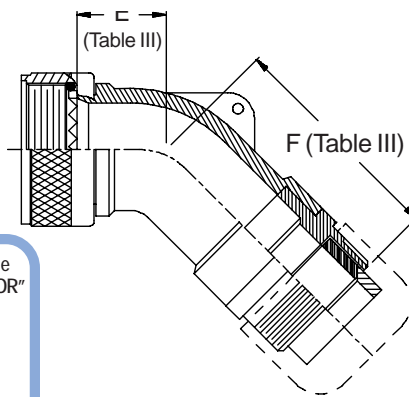

370-001
Submersible Cable Sealing Backshell
with Strain Relief
Low Profile - Rotatable Coupling



TABLE III: ELBOW DIMENSIONS

Shell Size		E		F		G		H	
Conn. Desig.	H	Max		Max		Max		Max	
A-F-L-S									
08	09	.457	(11.6)	1.810	(46.0)	.500	(12.7)	1.820	(46.2)
10	11	.520	(13.2)	1.869	(47.5)	.595	(15.1)	1.940	(49.3)
12	13	.582	(14.8)	1.929	(49.0)	.610	(15.5)	1.960	(49.8)
14	15	.645	(16.4)	2.359	(59.9)	.700	(17.8)	2.369	(60.2)
16	17	.738	(18.7)	2.469	(62.7)	.885	(22.5)	2.459	(62.5)
18	19	.926	(23.5)	2.659	(67.5)	.975	(24.8)	2.629	(66.8)
20	21	.926	(23.5)	2.659	(67.5)	.975	(24.8)	2.629	(66.8)
22	23	1.020	(25.9)	2.872	(72.9)	1.125	(28.6)	2.802	(71.2)
24	25	1.020	(25.9)	2.872	(72.9)	1.125	(28.6)	2.802	(71.2)
28		1.145	(29.1)	2.905	(73.8)	1.225	(31.1)	2.955	(75.1)
32		1.207	(30.7)	3.005	(76.3)	1.575	(40.0)	3.205	(81.4)
36		1.238	(31.4)	3.315	(84.2)	1.775	(45.1)	3.255	(82.7)

1. When maximum cable entry (page 21) is exceeded, Style 2 will be supplied. Dimensions E, F, G and H will not apply. Please consult factory.
2. Metric dimensions (mm) are indicated in parentheses.
3. Cable range is defined as the accommodations range for the wire bundle or cable. Dimensions shown are not intended for inspection criteria.
4. Interface O-Ring not supplied with connector designator A.
5. Consult factory for shorter lengths on straight backshells.

TABLE X: CABLE ENTRY

Dash No.	T Max	V Max	Cable Range	
			Min	Max
04	.780 (19.8)	.957 (24.3)	.125 (3.2)	.312 (7.9)
06	.780 (19.8)	1.145 (29.1)	.250 (6.4)	.437 (11.1)
08	.780 (19.8)	1.332 (33.8)	.387 (9.8)	.562 (14.3)
10	.780 (19.8)	1.332 (33.8)	.350 (8.9)	.625 (15.9)
12	.811 (20.6)	1.551 (39.4)	.500 (12.7)	.750 (19.1)
16	.905 (23.0)	1.770 (45.0)	.625 (15.9)	.937 (23.8)
20	1.092 (27.7)	2.113 (53.7)	.875 (22.2)	1.250 (31.8)
24	1.124 (28.5)	2.363 (60.0)	1.000 (25.4)	1.375 (34.9)
28	1.399 (35.5)	2.770 (70.4)	1.250 (31.8)	1.625 (41.3)
32	1.399 (35.5)	3.020 (76.7)	1.437 (36.5)	1.875 (47.6)

See inside back cover fold-out or pages 13 and 14 for unabridged Tables I and II.

TABLE II: STANDARD FINISHES

GLENAIR SYMBOL	FINISH
B	Cadmium Plate, Olive Drab
C	Anodize, Black
G	Hard Coat, Anodic
M	Electroless Nickel
NF	Cadmium Plate, Olive Drab Over Electroless Nickel

See Inside Back Cover for Additional Finish Options

TABLE XI: CABLE ENTRY

Dash No.	W Max	X Max	Y Max	Z Max	Cable Range	
					Min **	Max
03*	.437 (11.1)	.760 (19.3)	.843 (21.4)	.630 (16.0)	.156 (4.0)	.250 (6.4)
04*	.437 (11.1)	.760 (19.3)	.906 (23.0)	.755 (19.2)	.188 (4.8)	.312 (7.9)
06*	.500 (12.7)	.760 (19.3)	1.093 (27.8)	.942 (23.9)	.281 (7.1)	.438 (11.1)
08	.563 (14.3)	.760 (19.3)	1.187 (30.1)	1.067 (27.1)	.387 (9.8)	.562 (14.3)
10	.563 (14.3)	.760 (19.3)	1.281 (32.5)	1.192 (30.3)	.375 (9.5)	.625 (15.9)
12	.563 (14.3)	.760 (19.3)	1.500 (38.1)	1.380 (35.1)	.438 (11.1)	.750 (19.1)
16	.656 (16.7)	1.073 (27.3)	1.719 (43.7)	1.535 (39.0)	.625 (15.9)	.938 (23.8)
20	.656 (16.7)	1.323 (33.6)	2.062 (52.4)	1.848 (46.9)	.875 (22.2)	1.250 (31.8)
24	.656 (16.7)	1.323 (33.6)	2.312 (58.7)	2.255 (57.3)	1.000 (25.4)	1.375 (34.9)
28	1.188 (30.2)	1.572 (39.9)	2.719 (69.1)	2.505 (63.6)	1.250 (31.8)	1.625 (41.3)
32*	1.187 (30.1)	1.572 (39.9)	2.969 (75.4)	2.755 (70.0)	1.437 (36.5)	1.875 (47.6)
40*	1.125 (28.6)	1.572 (39.9)	3.531 (89.7)	3.255 (82.7)	1.875 (47.6)	2.375 (60.3)

* Not available in Style M clamp. ** Not Applicable Style D