



10K PSI / 700 BAR / 7000M
**SuperG55™ High-Pressure,
 Dry-Mate Subsea Connectors**



G55 R1 right angle cable connector plug



SuperG55™ CCP-RA- - How To Order					
Sample Part Number	G55	R1	15	03	-0001
Series	SuperG55™ = Underwater dry-mate				
Connector Style	R1 = Overmolded, right angle cable connector plug				
Shell Size	15, 20, 24				
Number of Contacts	See contact arrangements (page 23)				
Cable Length	in feet (0001 = 1 foot, 0002 = 2 feet, etc.)				

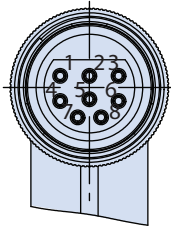
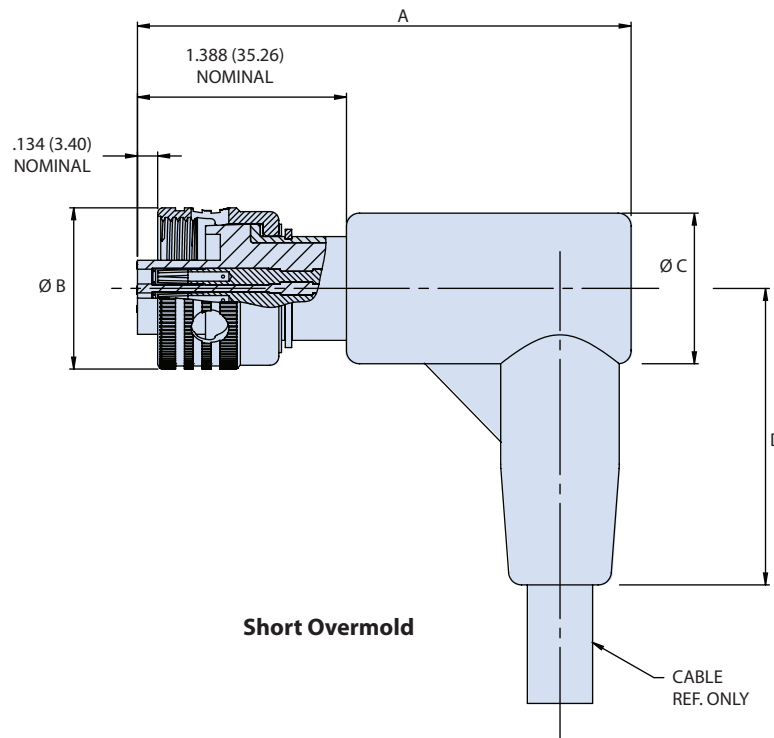

SUBSEA/ DEEPWATER: SUPERG55™

Dimensions				
Shell Size	Dim A Nominal	Dim B ±.15 (.006)	Dim C ±.25 (.10)	Dim D Nominal
15	3.278 (83.26)	1.070 (27.18)	1.00 (25.40)	1.968 (49.99)
20	3.518 (89.36)	1.450 (36.85)	1.380 (35.05)	2.759 (70.08)
24	3.778 (95.96)	1.700 (43.20)	1.640 (41.66)	3.179 (80.75)

NOTES

- 1508 Pin configuration shown. Other pin configurations available
- All contacts / pin configurations suit 16 AWG wire