

# 600-157 Composite-Hex-Coupling Wrench

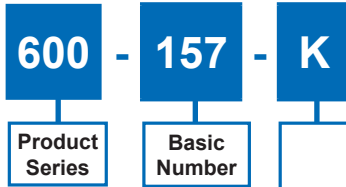

STAINLESS STEEL TOOL FOR USE WITH GLENAIR COMPOSITE BACKSHELLS



**Dash Number for Individual Wrench or:**  
*K* - Kit of dash numbers 08 thru 28, no case  
*KC* - "K" kit with case  
*KL* - Kit of dash numbers 32 thru 44, no case  
*KLC* = "KL" kit with case  
*KIT* = Kit of dash numbers 08 thru 44 with case

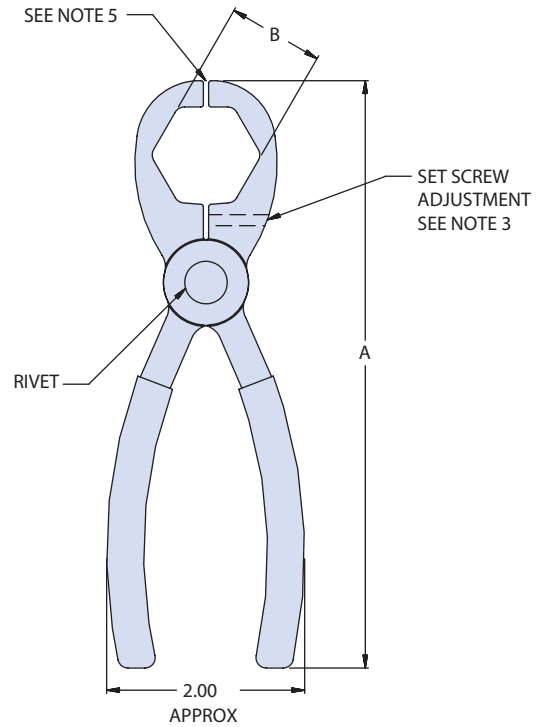
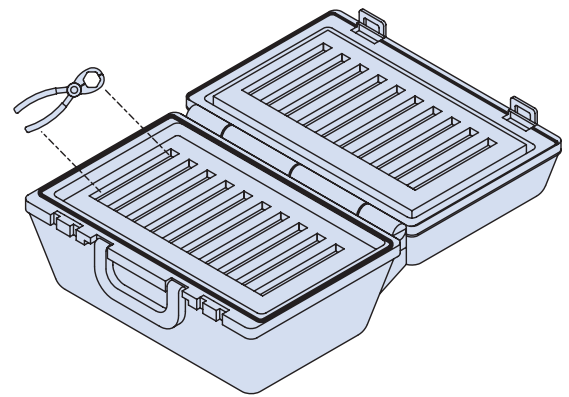

TABLE I: DASH NUMBER

Dash No.	A Ref	B Hex <sup>2</sup> Ref	Connector for Shell Size Codes		Composite Torque Inch Pounds In-Lbs Min/Max
			A & F	Code H	
08	6.70 (170.2)	.750 (19.1)	08	09	20/25
10	6.75 (171.5)	.875 (22.2)	10	11	20/30
12	6.81 (173.0)	1.000 (25.4)	12	13	25/35
14	6.88 (174.8)	1.125 (28.6)	14	15	25/35
16	6.95 (176.5)	1.250 (31.8)	16	17	30/40
18	7.05 (179.1)	1.375 (34.9)	18	19	30/40
20	7.15 (181.6)	1.500 (38.1)	20	21	35/45
22	7.38 (187.5)	1.625 (41.3)	22	23	35/45
24	7.44 (189.0)	1.750 (44.5)	24	25	35/45

### APPLICATION NOTES

- Use in conjunction with Glenair 600G161 torque wrench and 600-162B or 600-162BV bench mounts (see page 14).
- Adjust set screw per tool setting procedure GAP134 (available on Glenair.com). Once adjusted must fit Glenair hex composite coupling nuts
- Dash Number 08, 10, 12 only. Customer is responsible for maintaining adjustment to compensate for wear.
- Replace tool if excessive wear is observed
- Gap is permissible during tool use for coupling nut assembly
- If set screw becomes loose causing loss of adjustment reapply suitable thread locking compound
- Wrenches are made of passivated SST with vinyl grips.
- Using other manufacturer's hex wrench pliers or soft jaw coated pliers will result in premature fracturing or damage to the composite product



KC Option  
Approximate Case Dimensions: 13.5 x 15.5 x 3.875