



RJ45 AND USB 2.0 Contacts, Tools, and Accessories



310-001 Shrink Boot Adapter with Rotatable Coupling for 28840 Type Connectors

MIL-DTL-28840 Type



| How To Order | | | | | | |
|-----------------------|---|---|---|-----|---|----|
| Sample Part Number | 310 | G | S | 001 | M | 17 |
| Series/Basic Part No. | 310 - Shrink Boot Adapter | | | | | |
| Connector Designator | G = 28840 | | | | | |
| Angular Function | S = Straight For 45° and 90° versions contact factory | | | | | |
| Basic Part No. | 001 | | | | | |
| Finish | See Material and Finish Table | | | | | |
| Shell Size | 15, 17, 19 | | | | | |

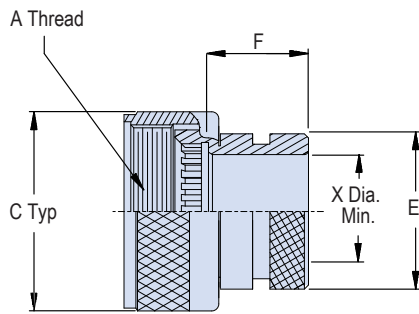

| Materials and Finishes | |
|------------------------|------------------------------|
| NF | Aluminum/ Cadmium olive drab |
| M | Aluminum/ Electroless nickel |
| MT | Aluminum/ Nickel PTFE |
| ZR | Aluminum/ Zinc-nickel black |
| Z1 | Stainless Steel/ Passivate |

| Dimensions | | | | | |
|------------|---------------|-------------|--------------|-------------|-------------|
| Shell Size | A Thread | C Typ | E Max | F Max | X Dia. Min. |
| 15 | M22 X 1 -- 6H | 1.07 (27.2) | .838 (21.3) | .940 (23.9) | .565 (14.4) |
| 17 | M25 X 1 -- 6H | 1.21 (30.7) | .963 (24.5) | .940 (23.9) | .690 (17.5) |
| 19 | M28 X 1 -- 6H | 1.36 (34.5) | 1.042 (26.5) | .940 (23.9) | .769 (19.5) |

| Recommended Shrink Boot* | | |
|--------------------------|------------------------------------|---------------------------------------|
| Shell Size | Shrink Boot with Low Temp Adhesive | Shrink Boot without Low Temp Adhesive |
| 15 | 770-028S904 Lipless boot | 770-028S904U Lipless boot |
| 17 | 770-028S906 | 770-028S906U |
| 19 | 770-028S906 | 770-028S906U |

* Shrink Boot **MUST** be ordered seperately.
Shrink boot material: compound 2013 low temperature polyolefin.