



USB 2.0 TYPE A

Series IPT (26482 Type) Bayonet Coupler



IPT343 Receptacle with USB

Female Interface to Solder Cup Termination

G



How to Order							
Sample Part Number	IPT343	02	16	2	A	H	F6
Basic Number	IPT343						
Connector Style ¹	02 = Wall Mount Receptacle 07 = Rear Panel Mount Jam Nut Receptacle						
Shell Size	16						
USB Performance	2 = 2.0						
USB Rear Jack Type	A = Type A						
Orientation Option	H = Horizontal V = Vertical						
Material/Finish	Omit for Cadmium/Olive Drab F6 = Black Polymer Electrocoat F7 = Conductive Black Zinc Nickel F11 = Electroless Nickel						

USB Orientation Options

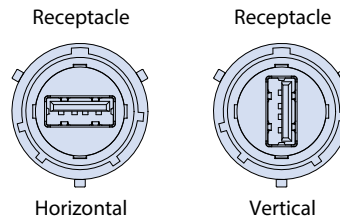

SOLDER CUP LAYOUTS FOR USB 2.0

Horizontal USB layout

-02 Style Solder Cup Layouts

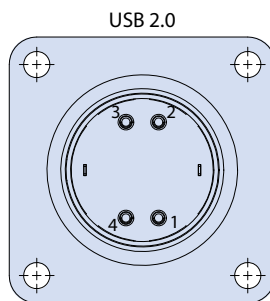

-07 Style Solder Cup Layouts

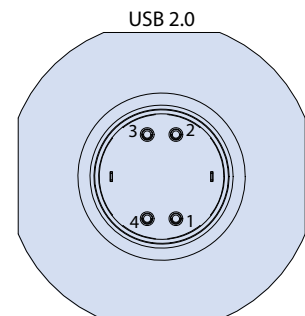



USB 2.0 TYPE A
Series IPT (26482 Type) Bayonet Coupler
 IPT343 Receptacle with USB
 Female Interface to Solder Cup Termination



02 - WALL MOUNT RECEPTACLE

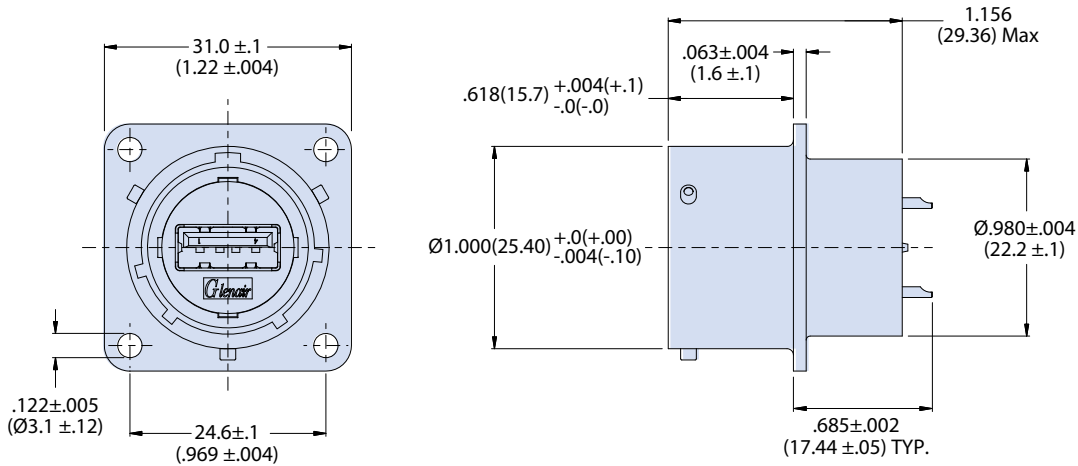

07 - REAR PANEL MOUNT JAM NUT RECEPTACLE

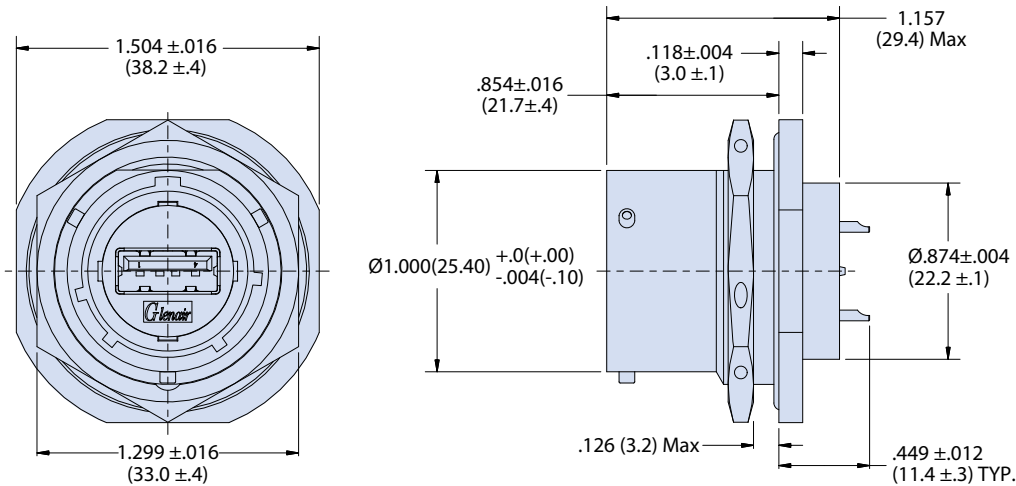

NOTES

1. See Section A panel cutout dimensions