

M29504/05 TYPE, STYLE 2 SOCKET TERMINUS FOR MIL-DTL-38999 SERIES III

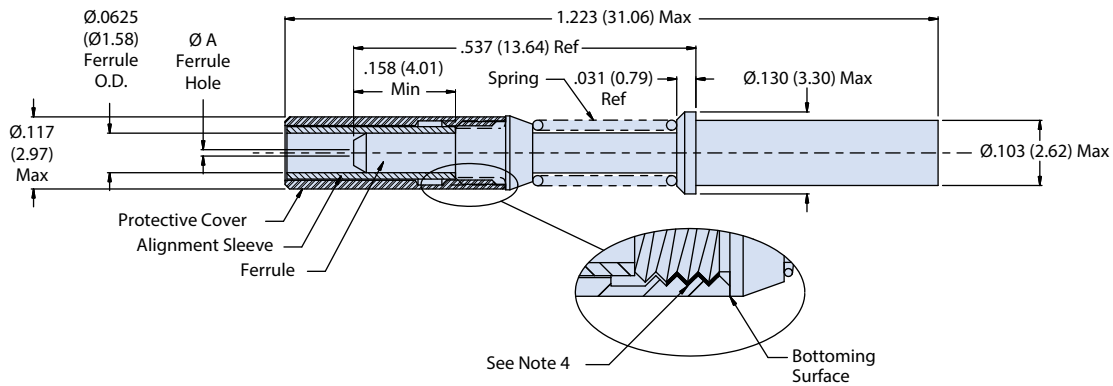

Part Number	Fiber Size Core/Cladding/Coating (Microns)	Ø A (Microns)	Ref. M29504/05-XXXX
181-009-125	9/125 (Singlemode)	125.5	M29504/05-4247
181-009-1265	9/125 (Singlemode)	126.0	M29504/05-4248
181-009-126	50/125 & 62.5/125	126.0	M29504/05-4249
181-009-127	50/125 & 62.5/125	127.0	M29504/05-4250
181-009-142	100/140	142.0	M29504/05-4253
181-009-145	100/140	145.0	M29504/05-4254
181-009-156	62.5/125/155 (Polyimide)	156.0	M29504/05-4251
181-009-157	62.5/125/155 (Polyimide)	157.0	M29504/05-4252
181-009-173	100/140/172 (Polyimide)	173.0	M29504/05-4255
181-009-175	100/140/172 (Polyimide)	175.0	M29504/05-4256
181-009-231	200/230	231.0	N/A
181-009-236	200/230	236.0	N/A
181-009-286	200/280	286.0	N/A
181-009-448	400/440	448.0	N/A

Consult factory for additional sizes and QPL status



Accessories	
Part Number	Description
181-001-S	Alignment Sleeve, Split Ceramic (standard)
181-001-K	Alignment Sleeve, Split Stainless Steel
181-001-C	Protective cover

NOTES

1. Insertion/extraction tool: M81969/14-03
2. Threaded protective cover must be retained using "Threadlocker Loctite 222" prior to insertion into connector. See Glenair assembly procedure GAP-019 for termination instructions
3. For socket dust cap use part number 187-019 over ferrule and 187-029 over protective cover
4. Alignment sleeve and protective cover are supplied with terminus and may be ordered separately (see accessories table)
5. Hand polishing tool: 182-001S or 182-001SW
6. Material/finish
 - Ferrule: zirconia ceramic
 - Alignment sleeve: zirconia ceramic or stainless steel/passivate
 - Terminus body, spring and cover: stainless steel/passivate