

## MIL-DTL-38999 Series III Type

### 233-221 Crimp-contact 90° “Cobra” plug with banding porch

ENVIRONMENTAL CONNECTORS

Part Number Development	
Sample Part Number	233-221 -G6 ME 25-35 S N -06
Series / Basic Part No.	233-221 = SuperNine crimp contact wire harness connectors
Connector Style*	G6 = 90° Low profile plug, with integral backshell
Finish	NF = Aluminum alloy/Cadmium Olive Drab MT = Aluminum alloy/Nickel PTFE ME = Aluminum alloy/Electroless Nickel ZR = Aluminum alloy/Black Zinc Nickel MN = Aluminum alloy, Tri-Nickel, 1,000 hrs salt spray
Shell Size-Insert Arrangement*	Per MIL-STD-1560, not all arrangements available for 233-221 connectors, contact factory
Contact Type	P = Pin S = Socket
Alternate Polarization*	A, B, C, D, E, N = Normal (IAW MIL-DTL-38999 Series III)
Cable Entry	See Cable Entry Code Table
Cable Exit Direction	See Figure 2, omit for 0° as shown in Figure 1

\*Refer to Section A for complete details

Plug Dimensions								
Shell Size	ØA Max	ØB Max	Coupling Nut Thread	C Max	Max Entry	PW1 Max	PW2 Max	PJ Max
9	.811 (20.60)	.858 (21.79)	.6250 -0.1P-0.3L-TS-2B	1.500 (38.10)	6	1.572 (39.93)	1.898 (48.21)	1.744 (44.30)
11	.929 (23.60)	.984 (24.99)	.7500 -0.1P-0.3L-TS-2B	1.560 (39.62)	8	1.632 (41.45)	1.958 (49.73)	1.804 (45.82)
13	1.110 (28.19)	1.157 (29.39)	.8750 -0.1P-0.3L-TS-2B	1.625 (41.28)	8	1.697 (43.10)	2.023 (51.38)	1.869 (47.47)
15	1.232 (31.29)	1.280 (32.51)	1.0000 -0.1P-0.3L-TS-2B	1.720 (43.69)	11	1.792 (45.52)	2.118 (53.80)	1.964 (49.89)
17	1.358 (34.49)	1.406 (35.71)	1.1875 -0.1P-0.3L-TS-2B	1.750 (44.45)	12	1.822 (46.28)	2.148 (54.56)	1.994 (50.65)
19	1.469 (37.31)	1.516 (38.51)	1.2500 -0.1P-0.3L-TS-2B	1.813 (46.05)	14	1.885 (47.88)	2.211 (56.16)	2.057 (52.25)
21	1.594 (40.49)	1.642 (41.71)	1.3750 -0.1P-0.3L-TS-2B	1.950 (49.53)	14	2.023 (51.38)	2.346 (59.59)	2.194 (55.73)
23	1.720 (43.69)	1.768 (44.91)	1.5000 -0.1P-0.3L-TS-2B	2.063 (52.40)	16	2.136 (54.25)	2.459 (62.46)	2.307 (58.60)
25	1.843 (46.81)	1.890 (48.01)	1.6250 -0.1P-0.3L-TS-2B	2.375 (60.33)	17	2.448 (62.18)	2.771 (70.38)	2.619 (66.52)

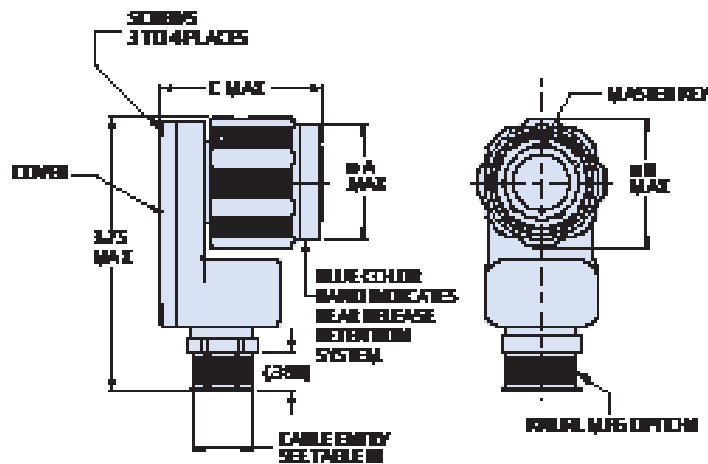
Cable Entry Code Table							
Code	Entry Size	Code	Entry Size	Code	Entry Size	Code	Entry Size
02	.125 (3.18)	06	.375(9.52)	10	.625(15.88)	14	.875(22.23)
03	.188 (4.78)	07	.438(11.13)	11	.688(17.48)	15	.938(23.83)
04	.250(6.35)	08	.500(12.70)	12	.750(19.05)	16	1.000(25.4)
05	.313(7.95)	09	.563(14.30)	13	.813(20.65)	17	1.063 (27.00)

Cable Exit Code Direction Table															
Code	D°	Code	D°	Code	D°	Code	D°	Code	D°	Code	D°	Code	D°	Code	D°
A	45	D	180	G	315	K	60	N	120	S	195	V	255	Y	330
B	90	E	225	H	15	L	75	P	150	T	210	W	285	Z	345
C	135	F	270	J	30	M	105	R	165	U	240	X	300		

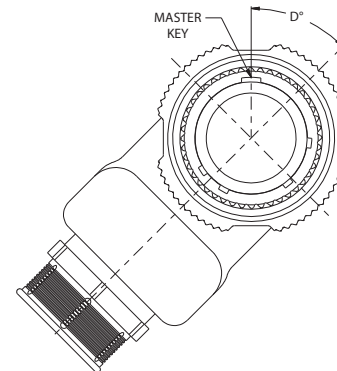
#### NOTES

- 233-221 Plug connector is designed to meet the general mechanical dimensional, electrical, and environmental requirements of MIL-DTL-38999, D38999/26, and MIL-STD-1560, except as shown and/or noted. Plug mates with and QPL manufacturers receptacles having the same shell size, insert arrangement, polarization, and opposite contact style
- Standard insert arrangements are in accordance with MIL-STD-1560, contact manufacturer for available arrangements. Not all arrangements are available for 233-221 plug connectors.
- Connector is supplied with contacts (including spares), insertion/removal tool and sealing plugs
- Material/finish
  - Barrel, coupling nut, cover: see part number development
  - Insulator: high grade rigid dielectric/N.A.
  - Seals, grommet: fluorosilicone blend/N.A.
  - Contacts: copper alloy/gold plate

**233-221 DIMENSIONS AND CABLE EXIT DIRECTIONS**

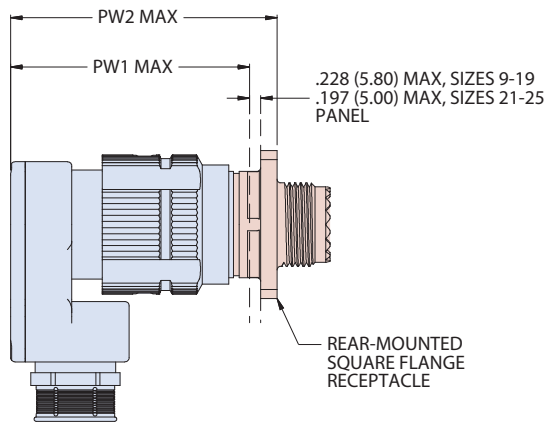


**FIGURE 1**

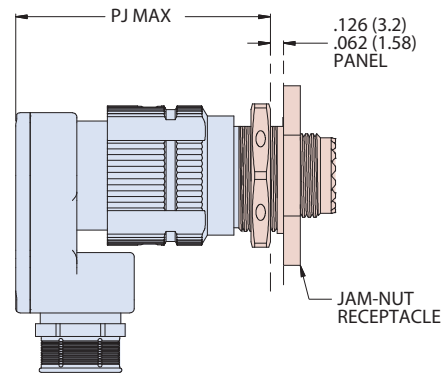


**FIGURE 2**

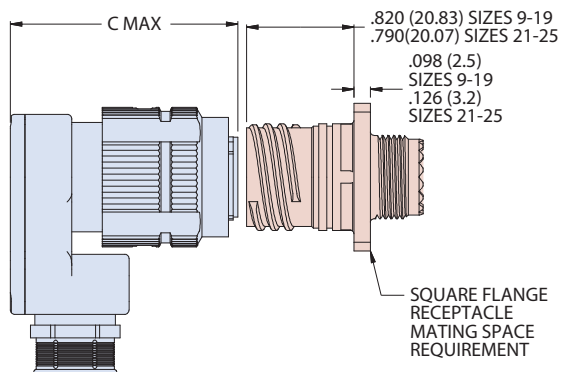
CABLE EXIT DIRECTION  
(DIRECTION A SHOWN)



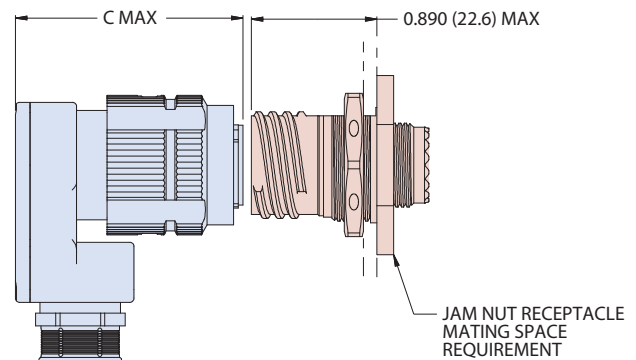
SHOWN MATED  
(SQUARE FLANGE)



SHOWN MATED  
(JAM NUT)



SQUARE FLANGE RECEPTACLE MATING SPACE REQUIREMENT



JAM NUT RECEPTACLE MATING SPACE REQUIREMENT