

# SuperNine® Environmental Series



## MIL-DTL-38999 Series III Type

### 233-208 Sealed PCB receptacle with stepped contacts

ENVIRONMENTAL CONNECTORS

Part Number Development									
Sample Part Number	233-208				-00	NF	17-8	P	N
Series / Basic Part No.	233-208 = SuperNine sealed PCB receptacle with washout standoffs								
Connector Style*	00 = Wall Mount Receptacle with Slotted Holes CM = Wall Mount Receptacle with Metric Clinch Nuts CS = Wall Mount Receptacle with Standard Clinch Nuts HM = Wall Mount Receptacle with Metric Helicoils HS = Wall Mount Receptacle with Standard Helicoils								
Finish	NF = Al alloy/Cadmium Olive Drab ME = Al alloy/Electroless Nickel			MT = Al alloy/Nickel PTFE ZR = Al alloy/Black Zinc Nickel			Consult factory for additional finish options		
Shell Size-Insert Arrangement*	Per MIL-STD-1560								
Contact Type	P = Pin, Gold, 1500 cycles    S = Socket, Gold, 1500 cycles    H = Pin, Pd/Ni, 1500 cycles    J = Socket, Pd/Ni, 1500 cycles								
Alternate Polarization*	A, B, C, D, E, N = Normal (IAW MIL-DTL-38999 Series III)								

\*Refer to Section A for complete details

Wall Mount Receptacle Dimensions													
Shell Size Code	Shell Size	A Thread -0.1P-0.3L-TS-2A	B Sq	B'	C Bsc	D Bsc <sup>3</sup>	E	F	G	G'	Ø J Min	L Thd	L' Thd
A	9	.6250	.948 (24.08) .925 (23.50)	1.094 (27.79) 1.054 (26.77)	.719 (18.26)	.594 (15.09)	.136 (3.45) .120 (3.05)	.224 (5.69) .208 (5.28)	.122 (3.10) .083 (2.11)	.179 (4.55) .140 (3.56)	.340 (8.64)	.112-40 UNC	M3X0.5
B	11	.7500	1.043 (26.49) 1.019 (25.88)	1.187 (30.15) 1.147 (29.13)	.812 (20.62)	.719 (18.26)		.202 (5.13)			.468 (11.89)		
C	13	.8750	1.137 (28.88) 1.114 (28.30)	1.281 (32.54) 1.241 (31.52)	.906 (23.01)	.812 (20.62)		.186 (4.72)			.572 (14.53)		
D	15	1.0000	1.232 (31.29) 1.208 (30.68)	1.344 (34.14) 1.304 (33.12)	.969 (24.61)	.906 (23.01)		.181 (4.60) .165 (4.19)			.705 (17.91)		
E	17	1.1875	1.323 (33.60) 1.299 (32.99)	1.437 (36.50) 1.397 (35.48)	1.062 (26.97)	.969 (24.61)		.202 (5.13) .186 (4.72)			.830 (21.08)		
F	19	1.2500	1.449 (36.80) 1.425 (36.20)	1.531 (38.89) 1.491 (37.87)	1.156 (29.36)	1.062 (26.97)					.934 (23.72)		
G	21	1.3750	1.575 (40.00) 1.551 (39.40)	1.625 (41.28) 1.585 (40.26)	1.250 (31.75)	1.156 (29.36)					1.055 (26.80)		
H	23	1.5000	1.701 (43.21) 1.677 (42.60)	1.750 (44.45) 1.710 (43.43)	1.375 (34.92)	1.250 (31.75)	.162 (4.11) .146 (3.71)	.114 (2.90)	.190 (4.83)	1.160 (29.46)	.138-32 UNC	M4X0.7	
J	25	1.6250	1.823 (46.30) 1.799 (45.69)	1.875 (47.63) 1.835 (46.61)	1.500 (38.10)	1.375 (34.92)		.250 (6.35) .234 (5.94)	.170 (4.32)	1.307 (33.20)			

#### NOTES

- 233-208 receptacle connector is designed to meet or exceed the mechanical, electrical, environmental and dimensional requirements of D38999/20 or /24 and MIL-STD-1560 except as shown and/or noted. Receptacle mates with any QPL manufacturer's D38999/26 Series III plug having the same shell size, insert arrangement and polarization.
- Insert arrangements IAW MIL-STD-1560, contact factory for additional arrangement options
- Front panel mount only
- 233-208 receptacle connector is designed with fixed PC tail contacts. Connector potting meets or exceeds protection rating IP67 and is environmentally sealed with a leak rate <math>1 \times 10^{-4}</math> ccHe/sec in an unmated condition.
- 233-208 receptacle connector is designed to withstand a minimum of 1500 mating durability cycles when mated to a SuperNine plug and appropriate contacts. Contact finish should be the same for both mating connectors to optimize performance.

## MIL-DTL-38999 Series III Type

### 233-208 Sealed PCB receptacle with stepped contacts

#### 00, CM, CS, HM AND HS - WALL MOUNT RECEPTACLES

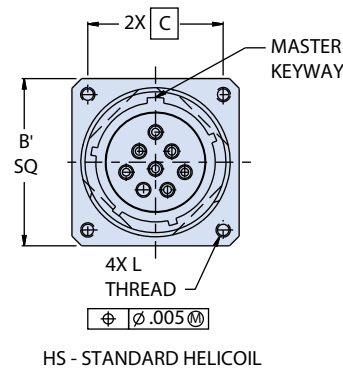
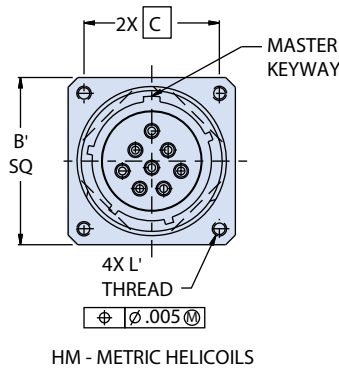
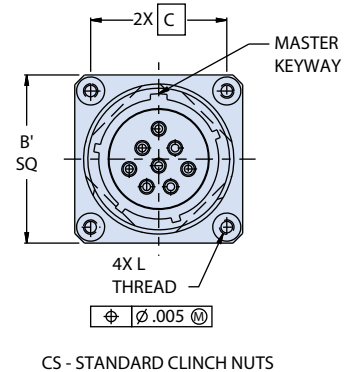
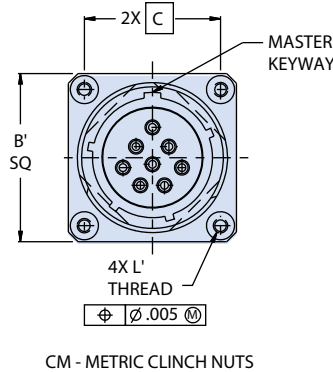
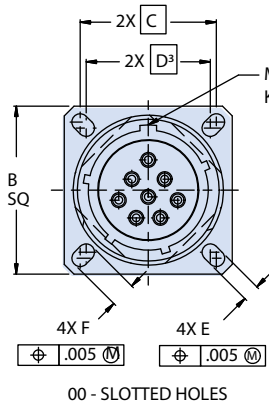

PC Tail Diameter	
Contact Size	ØV
23	.020 (.51) .018 (.46)
22	.020 (.51) .018 (.46)
20	.030 (.76) .028 (.71)
16	.040 (1.02) .038 (.97)
12	.072 (1.83) .070 (1.78)

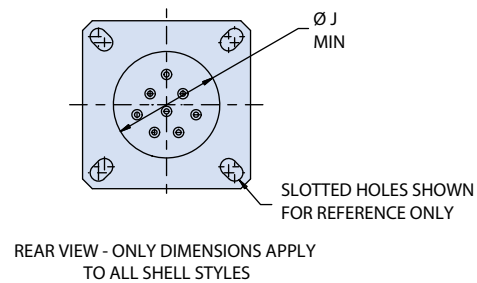
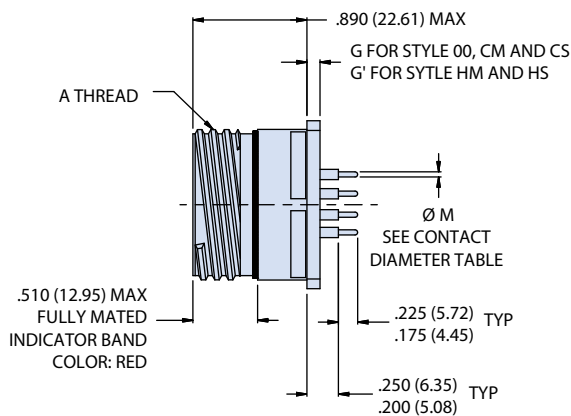

ENVIRONMENTAL CONNECTORS

#### NOTES (CONTINUED)

- Material/finish
  - Shell: see P/N development, finish
  - Contacts: copper alloy, see P/N development, contacts
  - insulators: high grade rigid dielectric/N.A.
  - Seals: fluorosilicone blend/N.A.
  - Potting: epoxy/N.A.



**MIL-DTL-38999 Series III Type**

**233-208-07 PCB jam nut receptacle with stepped contacts**

ENVIRONMENTAL CONNECTORS

Part Number Development									
Sample Part Number	233-208				-00	NF	17-8	P	N
Series / Basic Part No.	233-208 = SuperNine PCB receptacle with stepped contacts								
Connector Style*	07 = Jam Nut Mount Receptacle								
Finish	NF = Al alloy/cadmium Olive Drab ME = Al alloy/electroless Nickel		MT = Al alloy/nickel PTFE ZR = Al alloy/black Zinc Nickel		Consult factory for additional finish options				
Shell Size-Insert Arrangement*	Per MIL-STD-1560								
Contact Type	P = Pin, Gold, 1500 cycles   S = Socket, Gold, 1500 cycles   H = Pin, Pd/Ni, 1500 cycles   J = Socket, Pd/Ni, 1500 cycles								
Alternate Polarization*	A, B, C, D, E, N = Normal (IAW MIL-DTL-38999 Series III)								

Jam Nut Receptacle Dimensions									
Shell Size Code	Shell Size	A Thread -0.1P-0.3L-TS-2A	Ø B	C Sq	D Flat	E Thd ISO Metric	F	Ø G Min	Ø H Max
A	9	.6250	1.200 (30.48) 1.178 (29.92)	1.078 (27.38) 1.048 (26.62)	.654 (16.61) .645 (16.38)	M17 X 1.0-6g	.122 (3.10) .083 (2.11)	.340 (8.64)	.470 (11.94)
B	11	.7500	1.386 (35.20) 1.362 (34.59)	1.268 (32.21) 1.236 (31.39)	.755 (19.18) .745 (18.92)	M20 X 1.0-6g		.468 (11.89)	.590 (14.99)
C	13	.8750	1.512 (38.40) 1.488 (37.80)	1.390 (35.31) 1.358 (34.49)	.942 (23.93) .932 (23.67)	M25 X 1.0-6g		.572 (14.53)	.708 (17.98)
D	15	1.0000	1.638 (41.61) 1.614 (41.00)	1.516 (38.51) 1.484 (37.69)	1.066 (27.08) 1.056 (26.82)	M28 X 1.0-6g		.705 (17.91)	.865 (21.97)
E	17	1.1875	1.764 (44.81) 1.740 (44.20)	1.642 (41.71) 1.610 (40.89)	1.191 (30.25) 1.181 (30.00)	M32 X 1.0-6g*		.830 (21.08)	.985 (25.02)
F	19	1.2500	1.949 (49.50) 1.925 (48.90)	1.827 (46.41) 1.795 (45.59)	1.316 (33.43) 1.306 (33.17)	M35 X 1.0-6g	.153 (3.89) .114 (2.90)	.934 (23.72)	1.105 (28.07)
G	21	1.3750	2.075 (52.71) 2.051 (52.10)	1.953 (49.61) 1.921 (48.79)	1.441 (36.60) 1.431 (36.35)	M38 X 1.0-6g		1.055 (26.80)	1.220 (30.99)
H	23	1.5000	2.201 (55.91) 2.177 (55.30)	2.079 (52.81) 2.047 (51.99)	1.566 (39.78) 1.556 (39.52)	M41 X 1.0-6g		1.160 (29.46)	1.340 (34.04)
J	25	1.6250	2.323 (59.00) 2.299 (58.39)	2.205 (56.01) 2.173 (55.19)	1.691 (42.95) 1.681 (42.70)	M44 X 1.0-6g		1.307 (33.20)	1.455 (36.96)

\* Modified major diameter 31.95 - 31.80 (1.257 - 1.252)

**MIL-DTL-38999 Series III Type**

**233-208-07 PCB jam nut receptacles with stepped contacts**

**07 - JAM NUT MOUNT RECEPTACLE**

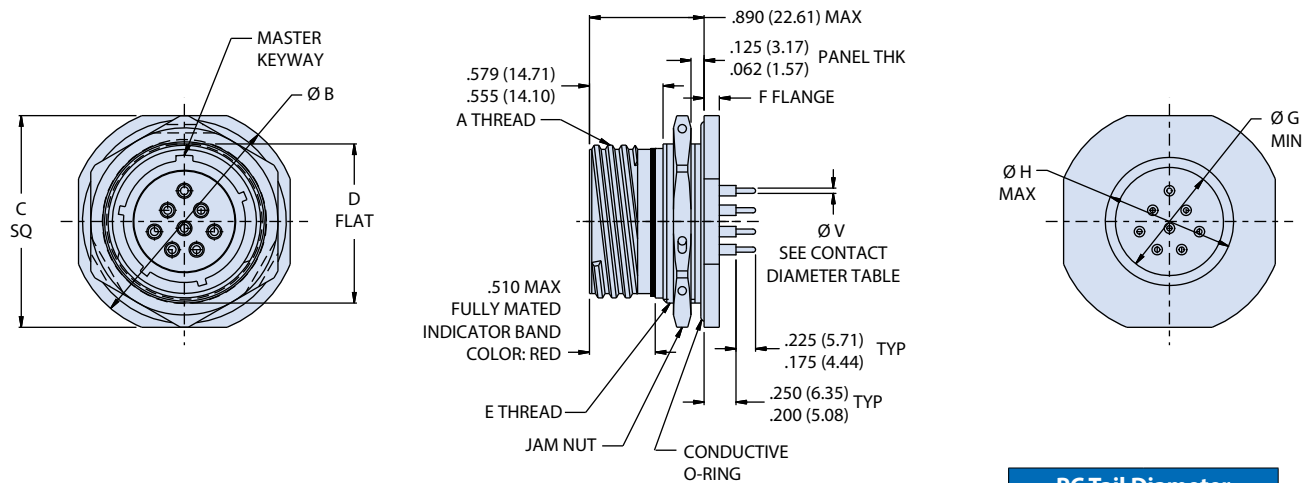

PC Tail Diameter	
Contact Size	ØV
23	.020 (.51)
	.018 (.46)
22	.020 (.51)
	.018 (.46)
20	.030 (.76)
	.028 (.71)
16	.040 (1.02)
	.038 (.97)
12	.072 (1.83)
	.070 (1.78)

**NOTES**

- 233-208-07 receptacle connector is designed to withstand a minimum of 1500 mating durability cycles when mated to a SuperNine® plug and appropriate contacts. Contact finish should be the same for both mating connectors to optimize performance.
- 233-208-07 receptacle connector is designed with fixed PC tail contacts. Connector Potting process meets or exceeds ingress protection rating IP67 and is environmentally sealed with a leak rate of  $< 1 \times 10^{-4}$  ccHe/sec in unmated condition.
- 233-208-07 receptacle connector is designed to meet or exceed the mechanical, electrical, environmental requirements of D38999/24 and MIL-STD-1560 except as shown and/or noted. Receptacle mates with any QPL manufacturer's D38999/26, Series III plug having same shell size, insert arrangement and polarization.
- Insert arrangements IAW MIL-STD-1560, contact manufacturer for additional arrangement options.
- Material/finish
  - Shell, jam-nut: see part number development, finish
  - Contacts: copper alloy/see part number development, contact type
  - Insulators: high-grade rigid dielectric/N.A.
  - Seals: fluorosilicone blend/N.A.
  - Potting: epoxy/N.A.
  - O-ring: silver plated aluminum in fluorosilicone (cho-seal 1298 or equivalent)