

8571-0013 Threaded Coupling Cordset, Plug-to-Receptacle, 10GbE



Lower installed cost. 100% tested. 10GbE. Save assembly time and cost with pre-wired SuperFly Datalink "White" assemblies for 10G Ethernet. These back-to-back Octaxial cordsets are terminated to Cat 6A aerospace-grade shielded cable. Two cable constructions are available: S/UTP (unshielded pairs with overall braid shield) or S/FTP (foil shielded pairs with overall braid). 24 AWG or 26 AWG stranded conductors. Series 882 connectors are designed for demanding aerospace environments.

SIZE AND WEIGHT SAVING

- Ultra small .415" (10.5 mm.) diameter coupling nut
- Integral backshell and cable seal

LOWER INSTALLED COST

- Factory-terminated
- 100% tested

HARSH ENVIRONMENT

- Aerospace grade Category 6A cable
- Shock, vibration, moisture

Wiring Diagram

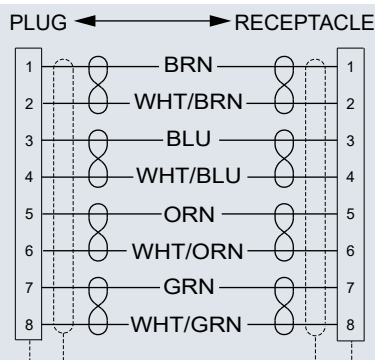

How To Order SuperFly Datalink Plug-to-Receptacle Cordset

Sample Part Number	8571-0013	-MT	-03	-72
Product	8571-0013 = Pre-wired SuperFly Datalink Assembly, Threaded Coupling, Plug to Receptacle			
Shell Finish	M = Electroless Nickel (aluminum shell) MT = Nickel-PTFE (aluminum shell) ZR = Black Zinc-Nickel (aluminum shell) Z2 = Gold (aluminum shell) ZMT = Nickel-PTFE (stainless steel shell)			
Cable Type	01 = Category 6A, #26 AWG, S/UTP* P/N 963-003-26 02 = Category 6A, #26 AWG, S/FTP** P/N 963-033-26 03 = Category 6A, #24 AWG, S/UTP* P/N 963-037-24 04 = Category 6A, #24 AWG, S/FTP** P/N 963-033-24 *S/UTP cable has overall braid shield **S/FTP cable has overall braid shield plus foil wrap on pairs			
Overall Length	Length in Inches (12 inch minimum)			

Construction

- **Shell, coupling nut, backshell:** aluminum alloy or stainless steel
- **Insulators:** high-grade rigid dielectric
- **Contacts:** copper alloy, 50 microinches gold over nickel plating
- **Grommets:** fluorosilicone
- **O-rings:** fluorosilicone
- **Shield sleeve, ferrule, spline:** copper alloy, electroless nickel plated
- **Cable:** aerospace-grade fluoropolymer per AS6070

Specifications

- **Operating temp.:** -65° to +175°C
- **Impedance:** 100 ohms
- **DWV:** 500 Vrms unmatd
- **Current Rating:** 1.5 A
- **IR:** 200 MΩ minimum
- **Durability:** 2000 mating cycles

El Ochito® White

