

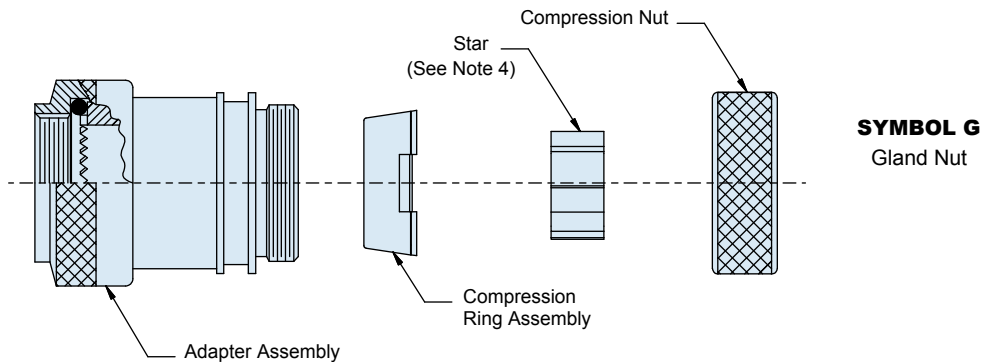

477-007
StarShield™ EMI/RFI Shield Termination Backshell
For MIL-DTL-38999 Series III & IV connectors

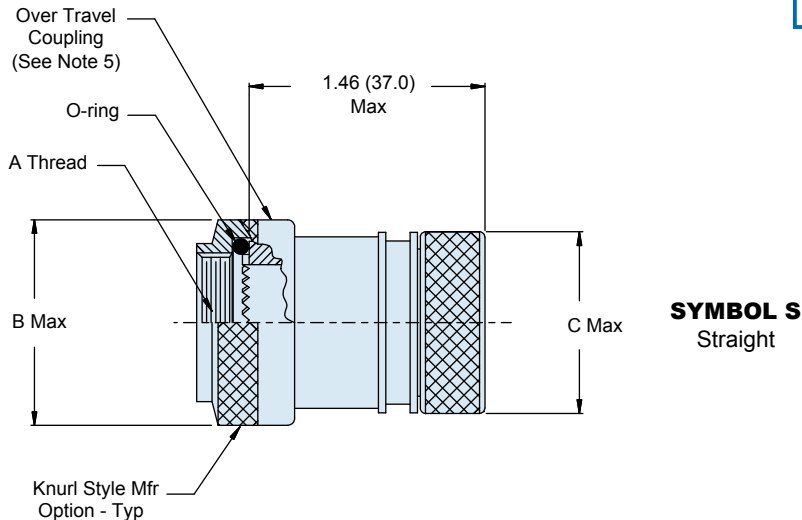

StarShield™ environmental, extended length backshell with self-nestor coupling

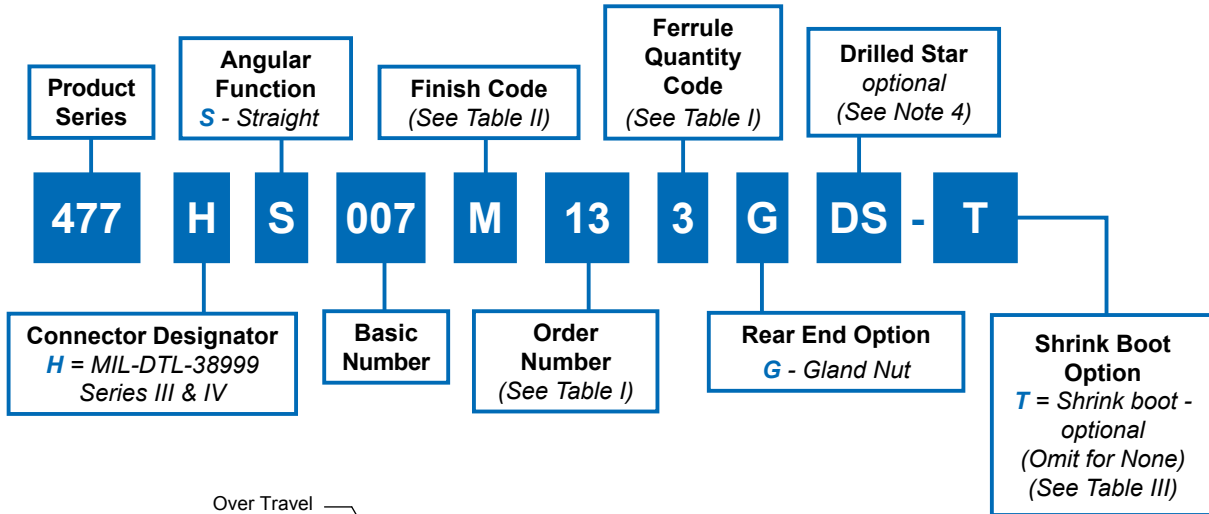

Dimensions in inches (millimeters) and are subject to change without notice.

477-007
StarShield™ EMI/RFI Shield Termination Backshell
 For MIL-DTL-38999 Series III & IV connectors



Table I: Dimensionsw

Order No	Connector Shell Size Ref	A Thread ISO Metric	B Dia Max	C Dia Max	Ferrule Quantity (See Note 4)	
					Std.	Opt.
09	A/9	M12 X 1 - 6H	.75 (19.0)	.69(17.5)	1	-
11	B/11	M15 X 1 - 6H	.87 (22.0)	.85 (21.5)	2	-
13	C/13	M18 X 1 - 6H	1.00 (25.5)	.89 (22.5)	3	-
15	D/15	M22 X 1 - 6H	1.20 (30.5)	1.00 (25.5)	5	-
17	E/17	M25 X 1 - 6H	1.32 (33.5)	1.12 (28.5)	6	7
19	F/19	M28 X 1 - 6H	1.46 (37.0)	1.24 (31.5)	7	-
21	G/21	M31 X 1 - 6H	1.52 (38.5)	1.38 (35.0)	9	11
23	H/23	M34 X 1 - 6H	1.65 (42.0)	1.50 (38.0)	10	13
25	J/25	M37 X 1 - 6H	1.83 (46.5)	1.61 (41.0)	12	17

Table II: Material and Finish Options

Code	Material; Finish Description
M	Aluminum; electroless nickel
MT	Aluminum; nickel - PTFE
NF	Aluminum; CAD/O. D. over electroless nickel
ZN	Aluminum; zinc nickel/O. D. over electroless nickel
ZR	Aluminum; zinc nickel/black over electroless nickel (RoHS)
Z1	Stainless steel; passivate
ZM	Stainless steel; electroless nickel

Table III: Shrink Boots

Shell Size	Shrink Boot Ref. Part Number
09	770-001S1 04
11	770-001S1 06
13	770-001S1 06
15	770-001S1 07
17	770-001S1 07
19	770-001S1 08
21	770-001S1 08
23	770-001S1 08
25	770-001S1 09

Material/Finish

Backshell, gland nut, compression ring, and star	Al alloy/Table II
Coupling nut	Stainless steel/passivate
O-ring	Silicone/n.a.

Notes:

1. Assembly identified with manufacturer's name and P/N, space permitting.
2. For effective grounding, connector with conductive finish should be used.
3. Glenair 600 series backshell assembly tools are recommended for assembly and installation.
4. Star not supplied with order number 09. Drilled star is available on order numbers 15-25 only. If optional ferrule qty per Table I is selected, one split and one solid star will be supplied.
5. Over-travel coupling design provides self-seating & self-locking functionality eliminating lock-wire requirements.
6. Ferrule kit sold separately.
 687-764 ferrule and HST device kit
 687-809 ferrule and sealing device kit
 687-748 solder ferrule
 687-841-01 HST flex device

Dimensions in inches (millimeters) and are subject to change without notice.