

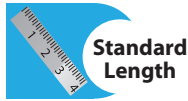

477-006
StarShield™ 30° EMI/RFI Shield Termination
Backshell
For MIL-DTL-38999 Series III & IV Connectors

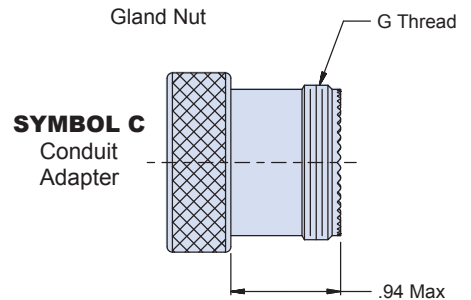

StarShield™ 30° environmental, high ferrule count backshell with self-nestor coupling

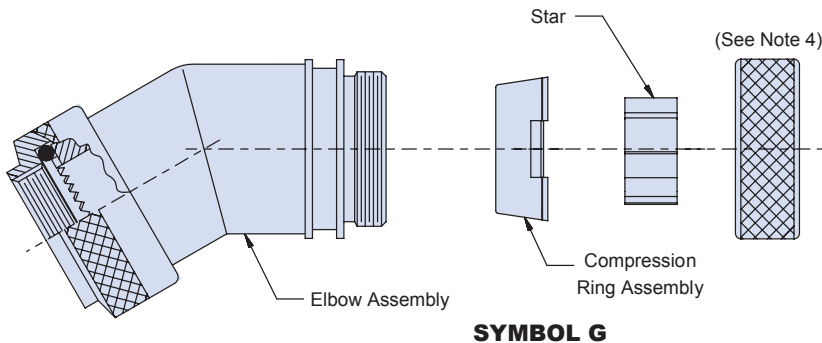
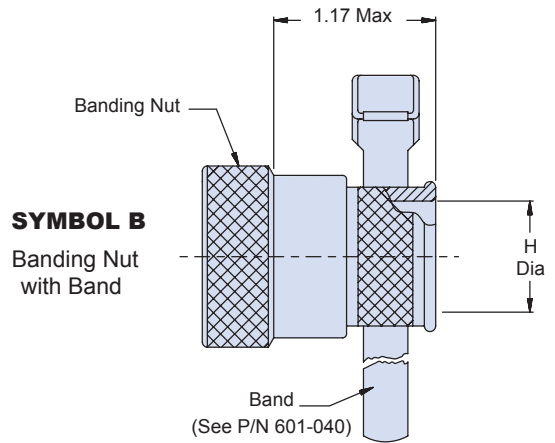
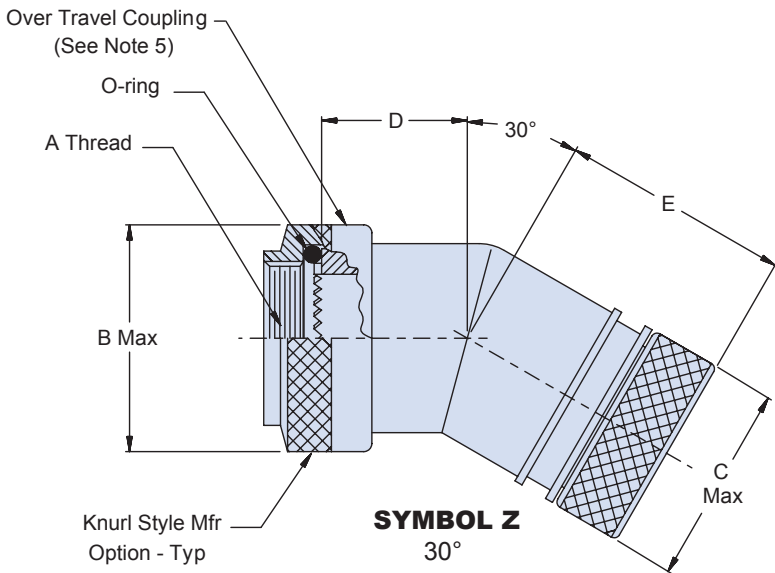
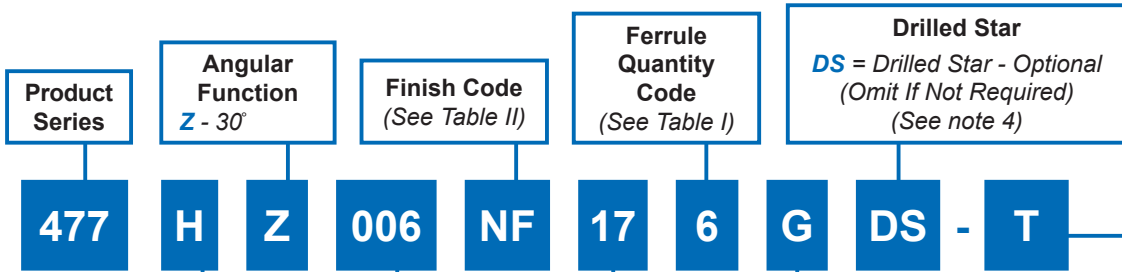

Dimensions in inches (millimeters) and are subject to change without notice.

477-006
StarShield™ 30° EMI/RFI Shield Termination
Backshell
For MIL-DTL-38999 Series III & IV Connectors



Table I: Dimensions

Order No	Connector Shell Size Ref	A Thread ISO Metric	B Dia Max	C Dia Max	D Max	E Max	G Thread ISO Metric	H ±.004 (0.10)	Ferrule Quantity (See Note 4)	
									Std.	Optional
09	A/9	M12 X 1 - 6H	.75 (19.0)	.69 (17.5)	.45(11.5)	.94 (24.0)	M12X 1 - 6g	.315 (8.00)	1	-
11	B/11	M15 X 1 - 6H	.87 (22.0)	.85 (21.5)	.47(12.0)	.96 (24.5)	M15X 1 - 6g	.531 (13.50)	2	-
13	C/13	M18 X 1 - 6H	1.00 (25.5)	.89 (22.5)	.49(12.5)	.98 (25.0)	M18 X 1 - 6g	.591 (15.00)	3	-
15	D/15	M22 X 1 - 6H	1.20 (30.5)	1.00 (25.5)	.51(13.0)	1.00 (25.5)	M22 X 1 - 6g	.709 (18.00)	5	-
17	E/17	M25 X 1 - 6H	1.32 (33.5)	1.12 (28.5)	.53(13.5)	1.02 (26.0)	M25 X 1 - 6g	.827 (21.00)	6	7
19	F/19	M28 X 1 - 6H	1.46 (37.0)	1.24 (31.5)	.55(14.0)	1.04 (26.5)	M28 X 1 - 6g	.945 (24.00)	7	-
21	G/21	M31 X 1 - 6H	1.52 (38.5)	1.38 (35.0)	.57(14.5)	1.06 (27.0)	M31 X 1 - 6g	1.063 (27.00)	9	11
23	H/23	M34 X 1 - 6H	1.65 (42.0)	1.50 (38.0)	.59(15.0)	1.08 (27.5)	M34 X 1 - 6g	1.181 (30.00)	10	11,12,13,15
25	J/25	M37 X 1 - 6H	1.83 (46.5)	1.61 (41.0)	.61(15.5)	1.10 (28.0)	M37 X 1 - 6g	1.299 (33.00)	12	13,14,15,17,18

Table II: Material and Finish Options

Code	Material; Finish Description
M	Aluminum; electroless nickel
MT	Aluminum; nickel - PTFE
NF	Aluminum; CAD/O. D. over electroless nickel
ZN	Aluminum; zinc nickel/O. D. over electroless nickel
ZR	Aluminum; zinc nickel/black over electroless nickel (RoHS)
Z1	Stainless steel; passivate
ZM	Stainless steel; electroless nickel

Table III: Shrink Boot

Shell Size	Shrink Boot Ref. Part Number
09	770-001S1 04
11	770-001S1 06
13	770-001S1 06
15	770-001S1 07
17	770-001S1 07
19	770-001S1 08
21	770-001S1 08
23	770-001S1 08
25	770-001S1 09

Materials/Finish

Backshell, elbows, coupling & gland nut, compression ring, star	Al alloy or CRES/ Table III
O-ring	Silicone/n.a.
Band	CRES/passivate

Notes:

1. Assembly identified with manufacturer's name and P/N, space permitting.
2. For effective grounding, connector with conductive finish should be used.
3. Glenair 600 series backshell assembly tools are recommended for assembly and installation.
4. Star not supplied with order number 09. Drilled star is available on order numbers 15-25 only. If optional ferrule qty per Table 1 is selected, one split and one solid star will be supplied
5. Over-travel coupling design provides self-seating & self-locking functionality eliminating lock-wire requirements.
6. Ferrule kit sold separately.
 687-764 ferrule and HST device kit
 687-809 ferrule and sealing device kit
 687-748 solder ferrule
 687-841-01 HST flex device

Dimensions in inches (millimeters) and are subject to change without notice.