

SPEEDMASTER Assembly Instructions

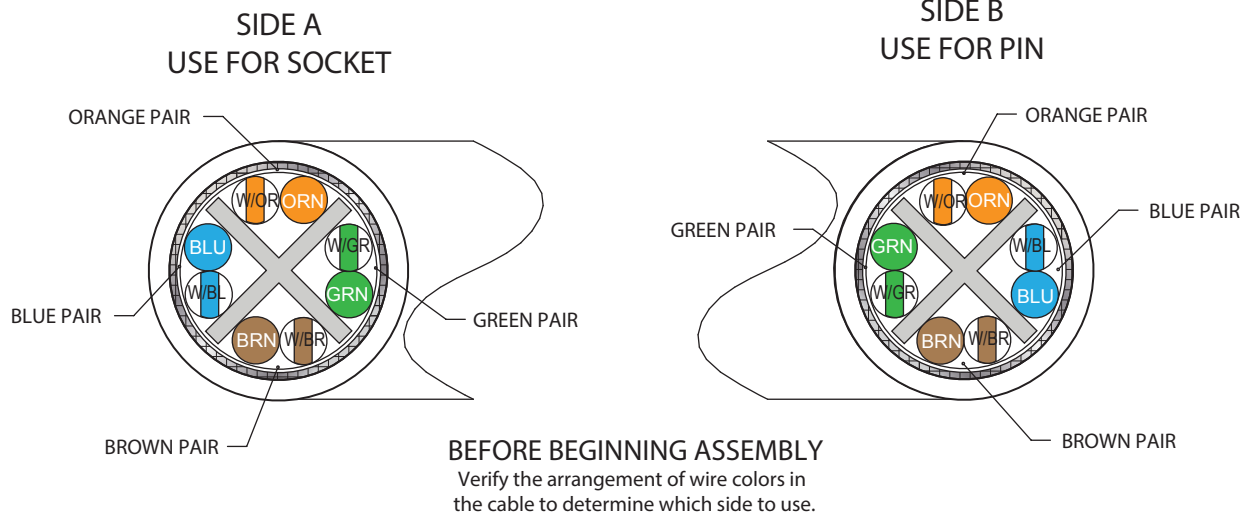

AI85082 SpeedMaster™ Contact Module Assembly Instructions



STEP 1

- Place o-ring onto thread ferrule so that it is seated behind the thread. (Figure 1)
- Slide retention ferrule with o-ring onto cable.

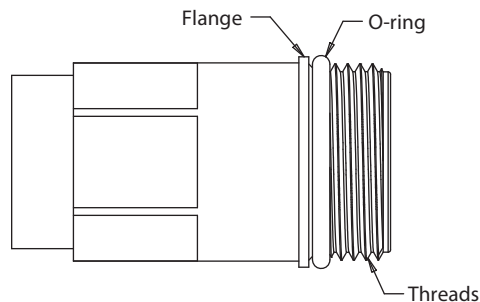

FIGURE 1

STEP 2

- Slide shield ferrule onto cable.
- Use proper tool to remove cable outer jacket to approximately 0.75 Inch.
- Comb braid out straight, and trim it to approximately .3 Inches. Fold braid back afterward.
- Trim outer tape, cable splice, and filler if any as close to the folded back braid shield as possible. (Figure 2)
- Use appropriate tool to strip the individual wires to .130 Inches max.

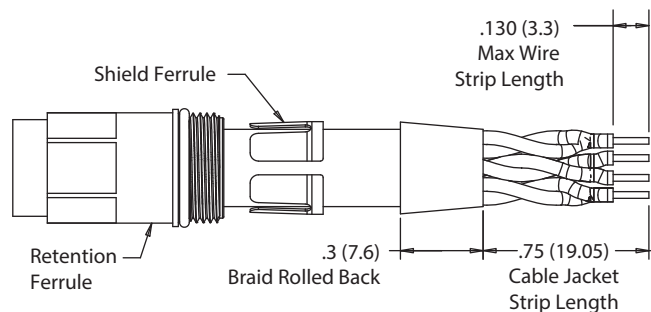

FIGURE 2

SPEEDMASTER Assembly Instructions



AI85082 SpeedMaster™ Contact Module Assembly Instructions

STEP 3

Maintain twist of pairs as best as possible. If needed – undo half a twist, do not over twist

- Crimp contacts onto each individual wire using Daniels crimp tool M22520/2-01 (Glenair P/N 809-015). Use Daniels positioner K41 (Glenair P/N 859-019) for sockets or positioner K42 (Glenair P/N 859-018) for pins.
- Insert each pair of wires into the appropriate quadrant on the isolator according to figure 3 for socket modules, and figure 4 for pin modules.

NOTES:

- Crossing of pairs is not recommended. (cables should only be terminated as pin to socket).
- Assembly instructions use socket module (858-100) for illustrations. Pin module (858-101) is assembled in the same fashion.

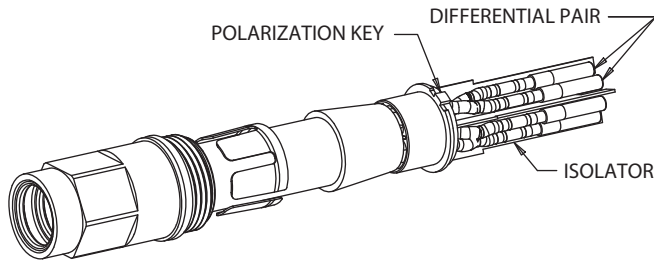

FIGURE 3
SOCKET MODULE PIN-OUT
FROM FRONT

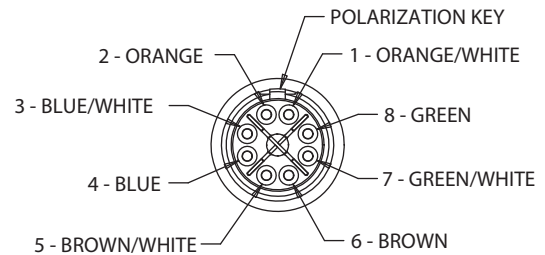
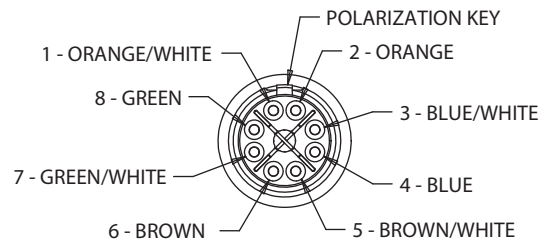

FIGURE 4
PIN MODULE PIN-OUT
FROM FRONT



STEP 4

- Push the cable all the way into the isolator so the wire pairs can be spread out easily
- Move the wires/contacts out of the way and insert the inner insulator on the isolator. Slide the inner insulator all the way onto the isolator.
- Snap each pair into the appropriate position on the inner insulator. Refer to figure 2 for sockets and figure 3 for pins.

Notes:

Be sure to maintain twist of each pair as close to the insulator as possible to improve signal. Do not over twist

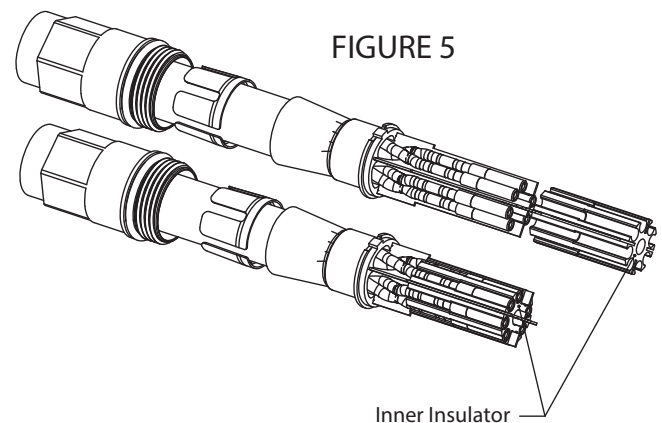

FIGURE 5

SPEEDMASTER Assembly Instructions



AI85082 SpeedMaster™ Contact Module Assembly Instructions

STEP 5

- A. Slide outer insulator onto module assembly. Be sure to align the slots/fins and polarization keys. (Figure 6 and 7)
- B. Fold braid shield forward onto termination zone. (Figure 7)
- C. Slide thread ferrule over shield ferrule and move both to the main shoulder. (Figure 8)
- D. Trim excessive braid to behind main shoulder. (Figure 8)

FIGURE 6

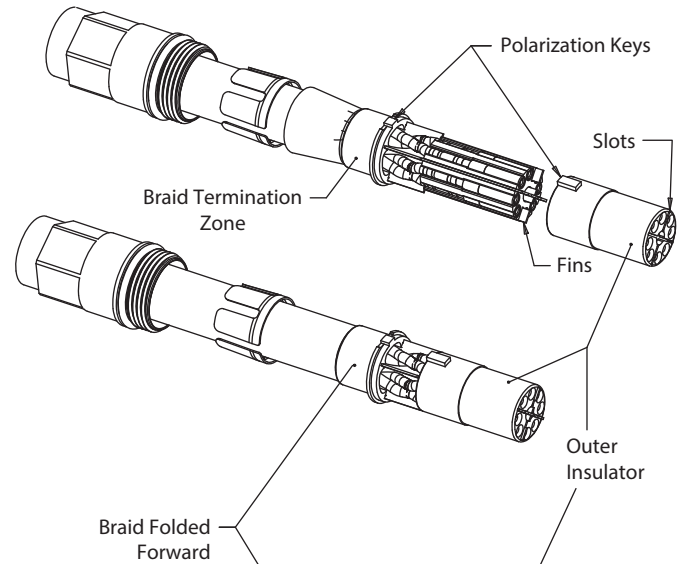
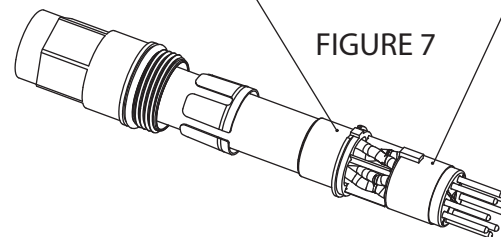

FIGURE 7



Pin Module (858-101) Shown For Reference

FIGURE 8

