

# MIL-PRF-24758-17 Adapter for Tapered Pipe Thread

A

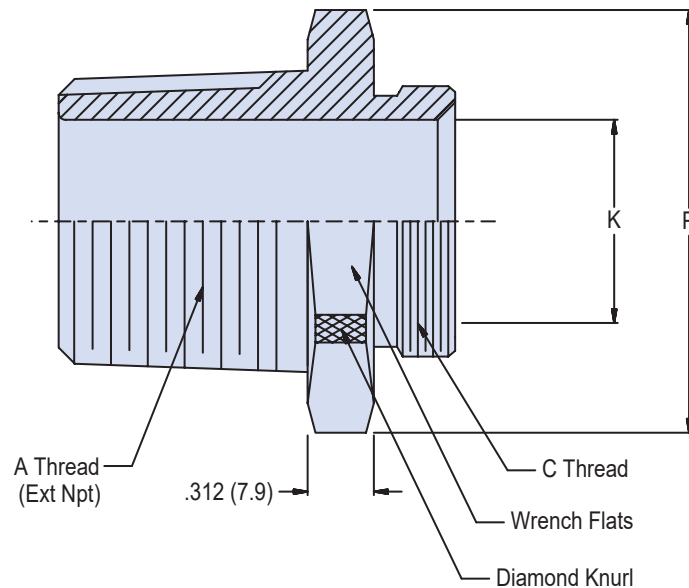
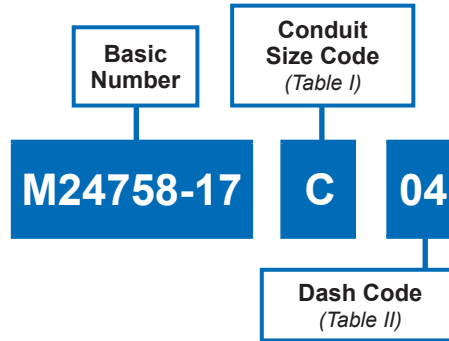

## APPLICATION NOTES

1. Assembly identified with manufacturer's code identification number (Glenair, part number and classification code 490).
2. The M24758-17 adapter couples any fittings that have a female tapered pipe thread to M24758-2, M24758-3 or M24758-4 fittings.
3. Material / Finish: Adapter, - 316 / electroless nickel, matte finish.
4. Metric dimensions (mm) are indicated in parentheses.

**MIL-PRF-24758-17**  
**Adapter for Tapered Pipe Thread**



MIL-PRF  
24758A

**A**

**TABLE I**

CONDUIT SIZE CODE	C CLASS - 2A THREAD	K DIA MIN	MAX ENTRY DASH NUMBER
A	.438-28 UNEF	.245 (6.22)	01
B	.688-24 UNEF	.495 (12.57)	03
C	.938-20 UNEF	.745 (18.92)	04
D	1.250-18 UNEF	.995 (25.27)	05
E	1.563-18 UNEF	1.245 (31.62)	06
F	1.875-16 UN	1.495 (37.97)	07
G	2.375-16 UN	1.995 (50.67)	08
H	2.875-16 UN	2.495 (63.37)	09
J	.563-24 UNEF	.370 (9.40)	02
K	.813-20 UNEF	.620 (15.75)	04
L	3.375-16 UN	2.995 (76.07)	10

**TABLE II**

DASH NUMBER	A EXTERNAL TAPER PIPE THREAD	P DIA MAX
01	.250-18 NPT	1.000 (25.40)
02	.375-18 NPT	1.130 (28.70)
03	.500-14 NPT	1.250 (31.75)
04	.750-14 NPT	1.500 (38.10)
05	1.000-11.5 NPT	1.750 (44.45)
06	1.250-11.5 NPT	2.130 (54.10)
07	1.500-11.5 NPT	2.380 (60.45)
08	2.000-11.5 NPT	2.880 (73.15)
09	2.500-8 NPT	3.380 (85.85)
10	3.000-8 NPT	4.130 (104.90)