

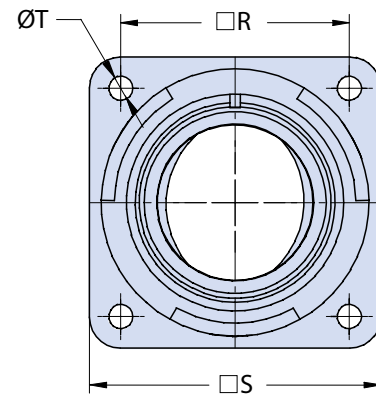

ITS 3100 A N5 and ITS 3100 R N5
ITS 4100 A N5 and ITS 4100 R N5
Front Panel Mount Square Flange Receptacle Assembly
with Class C (Environmental) IT3057 Cable Clamp

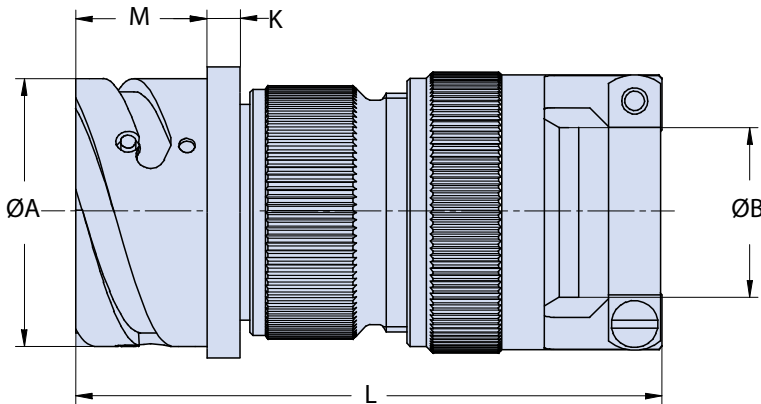
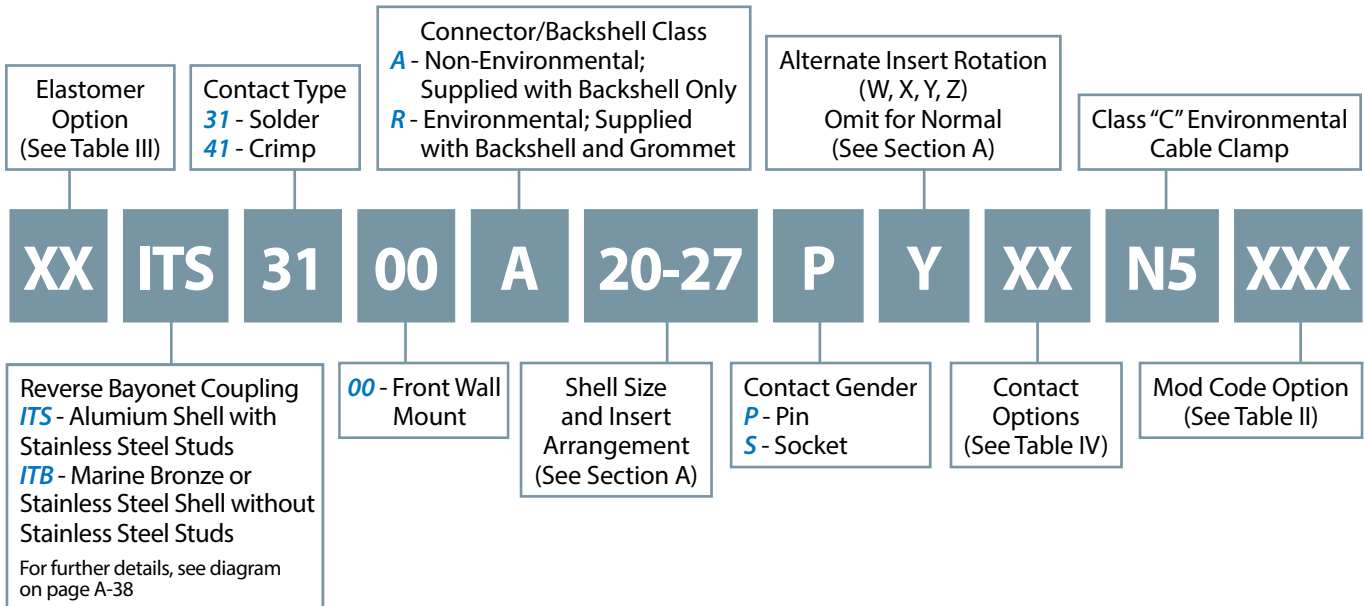

Application Notes

1. Front panel mount square flange receptacle assembly with a class C (environmental) IT3057 cable clamp for use with jacketed cable. Through mounting holes.
2. Connector/Backshell Class "A" (non-environmental)—Not supplied with wire sealing grommet; Class "R" (environmental)—Supplied with grommet.
3. Standard materials configuration consists of aluminum alloy. For platings, see TABLE II finish options.
4. Standard contact material consists of copper alloy with silver plating or gold plating.

**ITS 3100 A N5 and ITS 3100 R N5
ITS 4100 A N5 and ITS 4100 R N5
Front Panel Mount Square Flange Receptacle Assembly
with Class C (Environmental) IT3057 Cable Clamp**



TABLE I: DIMENSIONS

Shell Size	ØA +0.2 -0.1	ØB		K ±0.2	L Max.	M +0.4 -0	R ±0.2	S ±0.2	ØT +0.1 -0
		Open	Closed						
10 SL	18.2	7.93	2.38	2.8	73.0	14.2	18.25	25.4	3.2
14 S	24.5	11.12	5.84	3.2	76.0	14.2	23.00	30.4	3.2
16 S	27.2	13.48	8.00	3.2	73.0	14.2	24.60	32.5	3.2
16	27.2	13.48	8.00	3.2	84.0	19.0	24.60	32.5	3.2
18	30.7	15.87	9.60	4.0	88.0	19.0	27.00	35.0	3.2
20	34.0	19.00	11.30	4.0	90.0	19.0	29.40	38.0	3.2
22	37.3	19.00	11.30	4.0	89.0	19.0	31.75	41.0	3.2
24	40.9	23.80	15.50	4.0	95.0	20.6	34.90	44.5	3.7
28	46.7	23.80	15.50	4.0	103.0	20.6	39.70	50.9	3.7
32	53.4	31.75	23.40	4.0	111.0	22.2	44.50	57.0	4.3
36	59.6	35.00	23.40	4.0	123.0	22.2	49.20	63.5	4.3
40	65.5	41.25	29.90	4.0	123.0	22.2	55.55	69.9	4.3

B

TABLE II: MODIFICATION CODES

STANDARD MATERIAL AND FINISH (*)		
Sym	Description	RoHS
	Omit for Aluminum/ Cadmium Olive Drab	
F6	Aluminum/ Black Electrodeposited Paint	✓
F7	Aluminum/ Black Zinc Nickel	✓
F11	Aluminum/ Electroless Nickel	✓
MB	Marine Bronze/ Unplated	✓
FK	Stainless Steel/ Passivate	✓

TABLE III

ELASTOMER OPTIONS	
Sym	Description
	Omit for Polychloroprene Elastomer
FR	Fire Resistant Elastomer
S	Silicone Elastomer

TABLE IV: MODIFICATION CODES

CONTACT OPTIONS	
Sym	Description
B0	Connector without Contacts**
B1	Connector with Gold Plated Contacts
Omit for standard version (Silver plated)	

(*) For further options, please contact the factory.

(**) Crimp Contacts Only