

507-062
EMI/RFI Backshell
 With Lamp Thread Type Split Strain-Relief
 for MIL-DTL-83733 Connectors

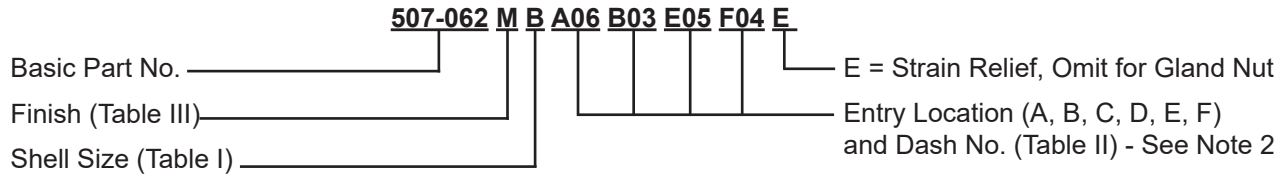

1. Metric dimensions (mm) are indicated in parentheses.
2. When entry options "C" and/or "D" are selected, entry option "B" cannot be selected. When "C" and "D" are selected on shell size A, the maximum dash number available is 02.
3. Material/Finish:
 Backshell, Adapter, Clamp,
 Ferrule = Al Alloy/See Table III
 Hardware = SST/Passivate

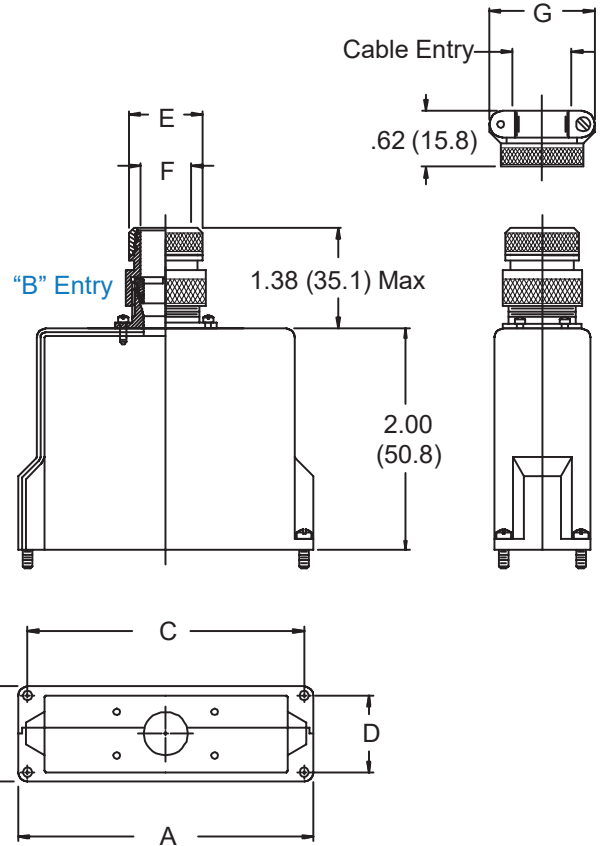
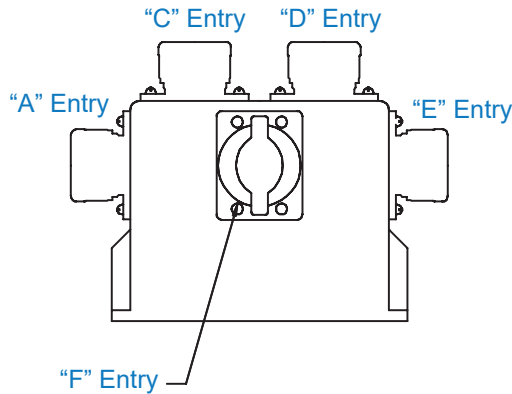

TABLE I: DIMENSIONS

Shell Size	A Dim	B Dim	C ± .005 (.1)	D ± .005 (.1)	Max Entry
A	2.095 (53.2)	1.000 (25.4)	1.895 (48.1)	.815 (20.7)	.750 (19.1)
B	3.395 (86.2)	1.000 (25.4)	3.195 (81.2)	.815 (20.7)	.750 (19.1)

TABLE II: CABLE ENTRY

Dash No.	E Max	F Entry Max	G Max	Cable Entry	
				Min	Max
01	.510 (13.0)	.078 (2.0)	.78 (19.8)	.062 (1.6)	.125 (3.2)
02	.577 (14.7)	.203 (5.2)	.97 (24.6)	.125 (3.2)	.250 (6.4)
03	.702 (17.8)	.328 (8.3)	1.05 (26.7)	.250 (6.4)	.375 (9.5)
04	.827 (21.0)	.453 (11.5)	1.16 (29.5)	.250 (6.4)	.500 (12.7)
05	.982 (24.9)	.578 (14.7)	1.22 (31.0)	.375 (9.5)	.625 (15.9)
06	1.077 (27.4)	.703 (17.9)	1.34 (34.0)	.500 (12.7)	.750 (19.1)

TABLE III: FINISHES

Sym.	Finish
B	Cadmium Plate, Olive Drab
M	Electroless Nickel
N	Cadmium Plate, Olive Drab, Over Nickel
NF	Cadmium Plate, Olive Drab, Over Electroless Nickel (500 Hour Salt Spray)

CONSULT FACTORY FOR OTHER AVAILABLE FINISHES