

507-195 EMI/RFI Micro-D Split Backshell Assembly with Clamp and Gland Nut Style Strain-Relief

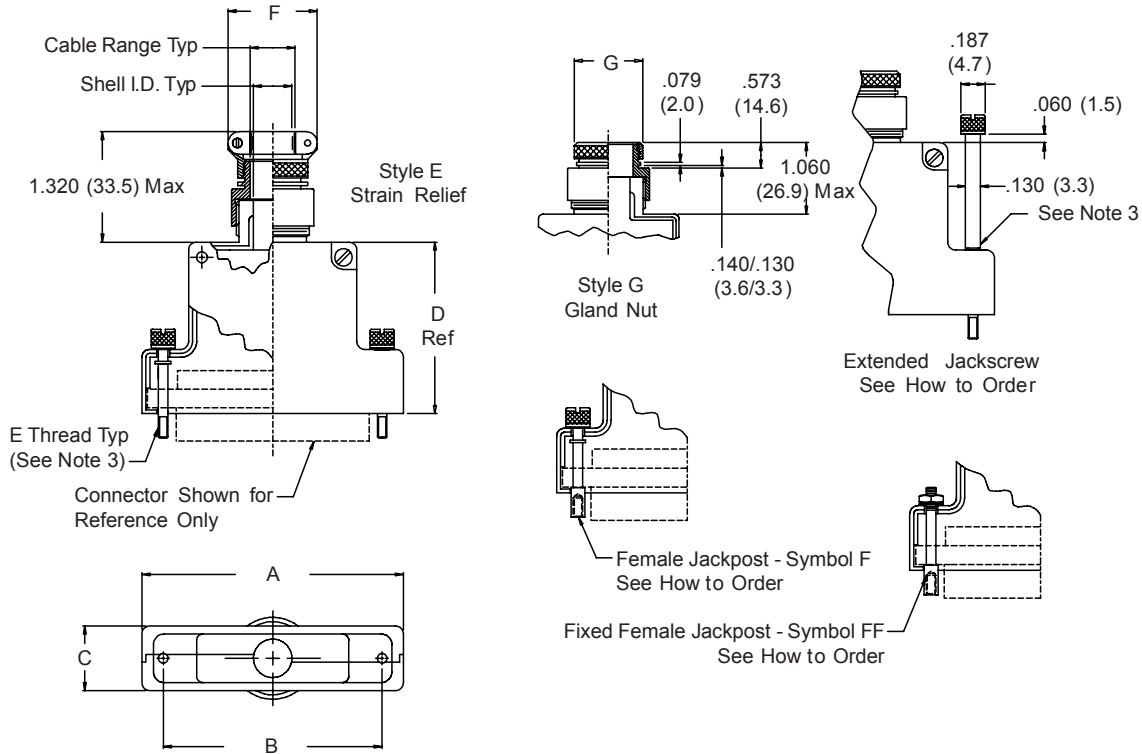

HOW TO ORDER					
Series/ Basic Number	Finish Symbol (Table III)	Shell Size (Table I)	Dash No. (Table II)	Jackscrew Option*	Gland Nut or Strain Relief
507-195		09		E – Extended Jackscrew	G – Gland Nut
		15			
		21			
		25			
		31			
		37			
		51			
100					
Sample Part Number:					
507-195	M	21	02	E	G
* SEE PAGE C-4 FOR COMPLETE INFORMATION					

NOTES:

1. Metric dimensions (mm) are indicated in parentheses.
2. Accommodates MS3109 through MS3117 and M85049/68 Lipped-Type Shrink Boots.
3. Jackscrew and Jackpost to float allowing Connector to engage prior to Jackscrew.

507-195
EMI/RFI Micro-D Split Backshell Assembly
with Clamp and Gland Nut Style Strain-Relief



MIL-DTL-83513
 Micro-D

TABLE I: SHELL SIZE, CABLE ENTRY, BACKSHELL & CONNECTOR INTERFACE DIMENSIONS

Shell Size	A Max	B ±.005 (0.13)	C Max	D ±.010 (0.25)	E Thread	Shell I.D.
09	.915 (23.4)	.565 (14.4)	.450 (11.4)	.701 (17.8)	2-56 UNC-2A	.310 (7.9)
15	1.065 (27.1)	.715 (18.2)	.450 (11.4)	.763 (19.4)	2-56 UNC-2A	.310 (7.9)
21	1.215 (30.9)	.865 (22.0)	.450 (11.4)	.795 (20.4)	2-56 UNC-2A	.310 (7.9)
25	1.315 (33.4)	.965 (24.5)	.450 (11.4)	.857 (21.8)	2-56 UNC-2A	.310 (7.9)
31	1.465 (37.2)	1.115 (28.3)	.450 (11.4)	.888 (22.6)	2-56 UNC-2A	.310 (7.9)
37	1.615 (41.0)	1.265 (32.1)	.450 (11.4)	.951 (24.2)	2-56 UNC-2A	.310 (7.9)
51	1.565 (39.8)	1.215 (30.9)	.495 (12.6)	1.013 (25.7)	2-56 UNC-2A	.360 (9.1)
100	2.305 (51.7)	1.800 (45.7)	.540 (13.7)	1.076 (27.3)	4-40 UNC-2A	.400 (10.2)

TABLE II: DASH NUMBER AND CABLE ENTRY

Dash No.	Clamp Range		F Dia	G
	Min	Max	Max	Max
02	.125 (3.2)	.250 (6.4)	.968 (24.6)	.515 (13.1)
03	.250 (6.4)	.375 (9.5)	1.046 (9.5)	.640 (16.3)
04	.312 (7.9)	.500 (12.7)	1.156 (29.4)	.765 (19.4)

TABLE III: FINISH OPTIONS

Symbol	Finish
B	Cadmium Plate/Olive Drab
C*	Black Anodize
G*	Anodic Hard Coat
J	Gold Iridite over Cadmium Plate over Electroless Nickel
LF	Cadmium Plate/Bright over Electroless Nickel
M	Electroless Nickel
N	Cadmium Plate/Olive Drab over Electroless Nickel
NC	Zinc Cobalt/Dark Olive Drab
NF	Cadmium Plate/Olive Drab over Electroless Nickel
T	Cadmium Plate/Bright over Electroless Nickel
U**	Cadmium Plate/Black
ZN	Zinc-Nickel Alloy/Olive Drab

*Anodize finish is not suitable for EMI shielding or grounding applications.

**Applicable to corrosion resisting steel backshells and accessories. Consult factory for other available finishes.

NOTES:

1. Metric dimensions (mm) are indicated in parentheses.
2. Accommodates MS3109 through MS3117 and M85049/68 Lipped-Type Shrink Boots.
3. Jackscrew and Jackpost to float allowing Connector to engage prior to Jackscrew.