

STYLE T - TOP ENTRY

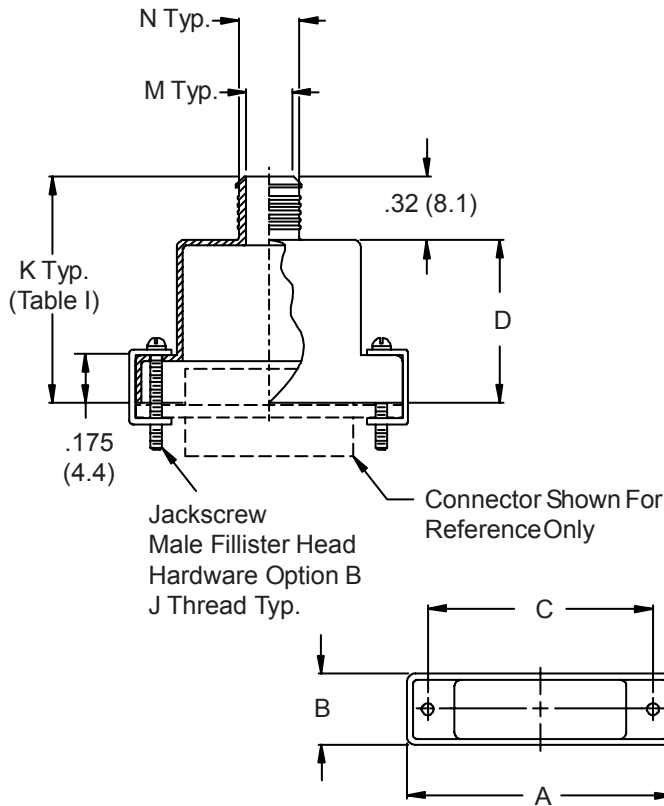

STYLE E - 45° ENTRY

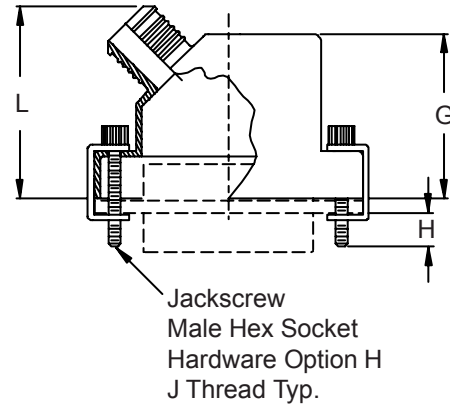

STYLE S - SIDE ENTRY

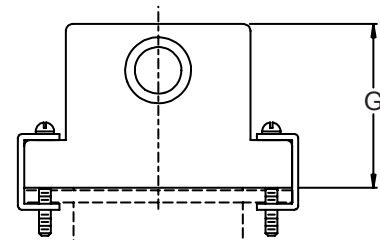

HOW TO ORDER

Series	Cable Entry Style	Basic Part No.	Shell Plating	Shell Size (Table I)	Hardware Options *	Cable Entry (Table II)	Qwik-Ty Option	Band Option
507	T - Top	088	XM - Electroless Nickel (See Opposite Page)	9	B - (2) male fillister head	04	S (Omit for Standard)	B 600-057 Band Supplied - (Omit if Not Required)
	S - Side			15	E - (2) extended jackscrew	05		
				21	H - (2) male hex socket	06		
				25	F - (2) female jackpost	07		
				31		08		
				37		09		
				51		10		
				100		11		
			12					

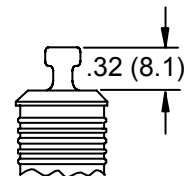

Sample Part Number:

507	T	088	XM	21	B	06	S	B
-----	---	-----	----	----	---	----	---	---

* SEE PAGE C-4 FOR COMPLETE INFORMATION

507-088 EMI/RFI Composite Micro-D Banding Backshell



MIL-DTL-83513
Micro-D

Composite shielded backshells offer over 40% weight savings compared to aluminum versions.

These composite backshells meet the requirements of SAE AIR 4567 and MIL-DTL-85049.

Available in a full range of sizes and options, composite backshells are designed for use with Glenair's EMI banding system for shield termination.

Material: High Grade Engineering Thermoplastic

Finish: Electroless Nickel

TABLE I: DIMENSIONS

SHELL SIZE	A	B	C	D	G
09	.775 (19.7)	.36 (9.1)	.565 (14.4)	.43 (10.9)	.650 (16.5)
15	.925 (23.5)	.36 (9.1)	.715 (18.2)	.44 (11.2)	.700 (17.8)
21	1.075 (27.3)	.36 (9.1)	.865 (22.0)	.56 (14.2)	.735 (18.7)
25	1.175 (29.8)	.36 (9.1)	.965 (24.5)	.62 (15.7)	.800 (20.3)
31	1.325 (33.7)	.36 (9.1)	1.115 (28.3)	.68 (17.3)	.860 (21.8)
37	1.475 (37.5)	.36 (9.1)	1.265 (32.1)	.72 (18.3)	.925 (23.5)
51	1.425 (36.2)	.40 (10.2)	1.215 (30.9)	.75 (19.1)	.975 (24.8)
100	2.160 (54.9)	.45 (11.4)	1.800 (45.7)	.81 (20.6)	1.050 (26.7)

SHELL SIZE	H REF	J THREAD	K ±.03 (0.8)	L MAX
09	.154 (3.9)	2-56 UNC-2	.75 (19.1)	1.00 (25.4)
15	.154 (3.9)	2-56 UNC-2	.76 (19.3)	1.03 (26.2)
21	.154 (3.9)	2-56 UNC-2	.88 (22.4)	1.05 (26.7)
25	.154 (3.9)	2-56 UNC-2	.94 (23.9)	1.09 (27.7)
31	.154 (3.9)	2-56 UNC-2	1.00 (25.4)	1.13 (28.7)
37	.154 (3.9)	2-56 UNC-2	1.04 (26.4)	1.16 (29.5)
51	.154 (3.9)	2-56 UNC-2	1.07 (27.2)	1.25 (31.8)
100	.184 (4.7)	4-40 UNC-2	1.13 (28.7)	1.32 (33.5)

TABLE II: CABLE ENTRY

Cable Entry	Shell Size	M Entry Dia	N Dia
04	09 THRU 100	.125 (3.2)	.219 (5.6)
05	09 THRU 100	.156 (4.0)	.250 (6.4)
06	09 THRU 100	.188 (4.8)	.281 (7.1)
07	09 THRU 100	.219 (5.6)	.313 (8.0)
08	09 THRU 100	.250 (6.4)	.344 (8.7)
09	31 THRU 100	.281 (7.1)	.375 (9.5)
10	51 THRU 100	.312 (7.9)	.406 (10.3)
11	100 ONLY	.344 (8.7)	.438 (11.1)
12	100 ONLY	.375 (9.5)	.469 (11.9)

Metric dimensions (mm) are indicated in parentheses.