

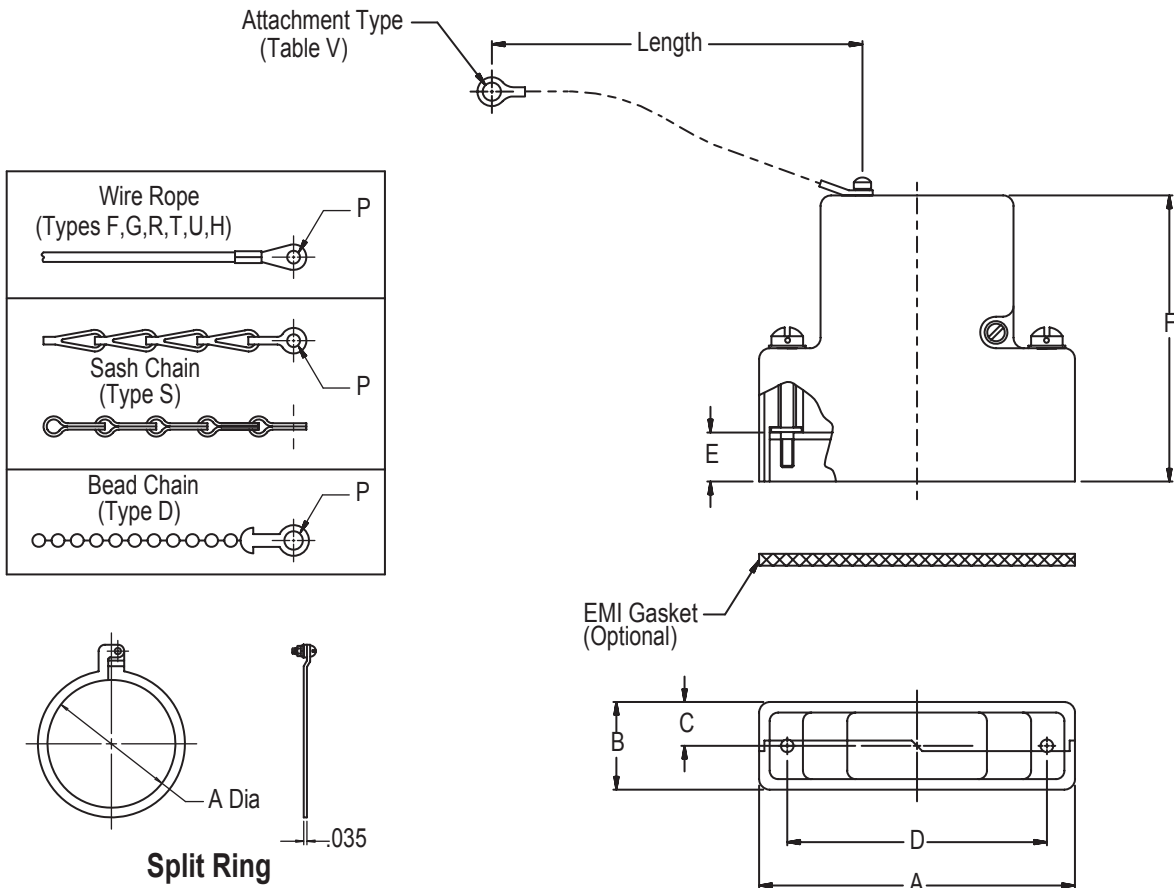

550-200 D-Subminiature Shorting Cap Split Backshells

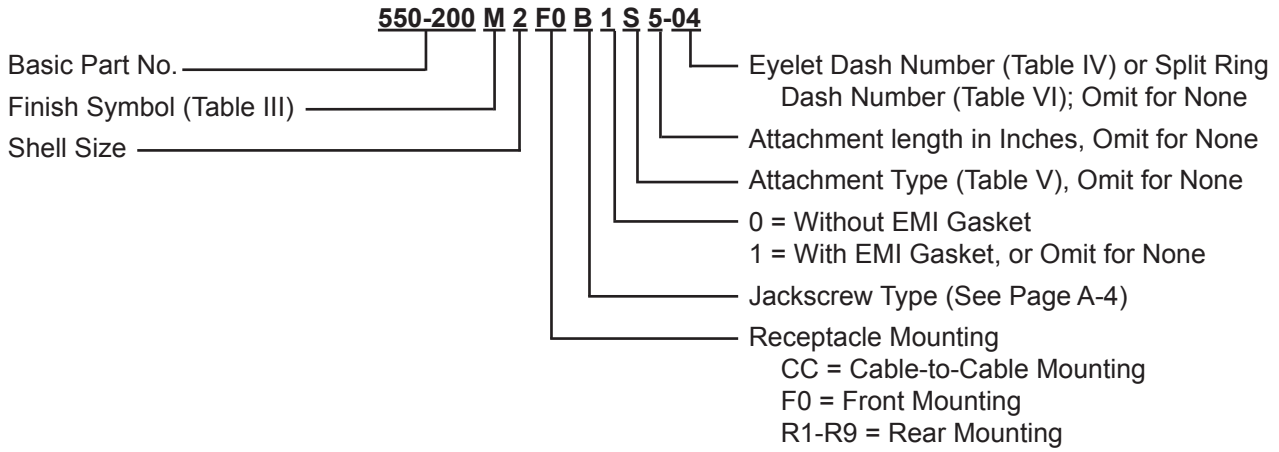

550-200 D-Subminiature Shorting Cap Split Backshells



TABLE I: Common Backshell Dimensions

Dash No.	A Max	B Max	C	D ± .005 (0.13)
1	1.393 (35.4)	.624 (15.8)	.322 (8.2)	.984 (25.0)
2	1.706 (43.4)	.624 (15.8)	.322 (8.2)	1.312 (33.3)
3	2.265 (57.5)	.624 (15.8)	.322 (8.2)	1.852 (47.0)
4	2.900 (73.7)	.624 (15.8)	.322 (8.2)	2.500 (63.5)
5	2.800 (71.1)	.735 (18.7)	.375 (9.5)	2.406 (61.1)
6	2.900 (73.7)	.844 (21.4)	.422 (10.7)	2.500 (63.5)

TABLE II: Cable Mounting Dimensions

Dash No.	Panel Thickness	E	F		
			Sizes 1 & 2	Sizes 3 to 5	Size 6
CC	N/A	.174 (4.4)	1.451 (36.9)	1.671 (42.4)	1.820 (46.2)
F0	N/A	.343 (8.7)	1.625 (41.3)	1.844 (46.8)	2.000 (50.8)
R1	.031 (0.8)	.247 (6.3)	1.525 (38.7)	1.745 (44.3)	1.890 (48.0)
R2	.047 (1.2)	.231 (5.9)	1.509 (38.3)	1.728 (43.9)	1.875 (47.6)
R3	.062 (1.6)	.216 (5.5)	1.500 (38.1)	1.720 (43.7)	1.860 (47.2)
R4	.093 (2.4)	.185 (4.7)	1.470 (37.3)	1.690 (42.9)	1.829 (46.5)
R5	.104 (2.6)	.174 (4.4)	1.451 (36.9)	1.671 (42.4)	1.820 (46.2)
R6	.125 (3.2)	.153 (3.9)	1.430 (36.3)	1.650 (41.9)	1.798 (45.7)
R7	.156 (4.0)	.125 (3.2)	1.400 (35.6)	1.620 (41.1)	1.767 (44.9)
R8	.135 (3.4)	.140 (3.6)	1.417 (36.0)	2.637 (41.6)	1.805 (45.8)
R9	.188 (4.8)	.094 (2.4)	1.368 (34.7)	2.590 (40.4)	1.740 (44.2)

TABLE III: Finishes

Symbol	Description
A	Cadmium Plate/Bright Dip
B	Cadmium Plate/Olive Drab
J	Gold Iridite over Cadmium Plate over Nickel
M	Electroless Nickel
N	Cadmium Plate/Olive Drab over Nickel
NF	Cadmium/Olive Drab over Electroless Nickel (1,000 Hr. Salt Spray)
T	Cadmium Plate/Bright Dip over Nickel
Y	Gold Iridite over Cadmium Plate

TABLE IV: Attachment Diameter P

Dash No.	P Dia ± .010 (0.25)
01	.140 (3.6)
02	.182 (4.6)
03	.191 (4.9)
04	.197 (5.0)
05	.167 (4.2)
06	.125 (3.2)
07	.218 (5.5)
09	.156 (4.0)
00	No Eyelet

TABLE V: Attachment Options

Symbol	Description
D	Bead Chain, CRES, Passivated
F	Wire Rope, Nylon Jacket
G	Nylon Rope
H	Wire Rope, Teflon Jacket
R	Wire Rope, PVC Jacket
T	Wire Rope, No Jacket
S	#8 Sash Chain, CRES, Passivated
U	Wire Rope, Polyurethane Jacket

TABLE VI: Split Ring Diameter and Maximum Mandrel Diameter

Dash No.	A Dia	Max Mandrel Dia (See Note 3)
50	.425 (10.8)	.410 (10.4)
52	.485 (12.3)	.470 (11.9)
54	.640 (16.3)	.625 (15.9)
56	.750 (19.1)	.735 (18.7)
58	.890 (22.6)	.875 (22.2)
60	1.015 (25.8)	1.000 (25.4)
62	1.095 (27.8)	1.080 (27.4)
64	1.130 (28.7)	1.115 (28.3)
66	1.250 (31.8)	1.235 (31.4)
68	1.350 (34.3)	1.335 (33.9)
70	1.375 (34.9)	1.360 (34.5)
72	1.485 (37.7)	1.470 (37.3)
74	1.625 (41.3)	1.610 (40.9)
76	1.750 (44.5)	1.735 (44.1)
78	1.875 (47.6)	1.860 (47.2)
80	1.980 (50.3)	1.965 (49.9)
82	2.060 (52.3)	2.045 (51.9)
84	2.235 (56.8)	2.220 (56.4)
86	2.310 (58.7)	2.295 (58.3)
88	2.475 (62.9)	2.460 (62.5)
90	2.655 (67.4)	2.640 (67.1)
92	2.810 (71.4)	2.795 (71.0)
94	3.045 (77.3)	3.030 (77.0)

1. Metric dimensions (mm) are indicated in parentheses.
2. **DO NOT USE CONNECTORS WITH FLOAT MOUNTINGS.**
3. Maximum recommended diameter of Mandrel over which assembled ring will rotate freely.