



550-033 D-Subminiature Dual Banding Split Backshell

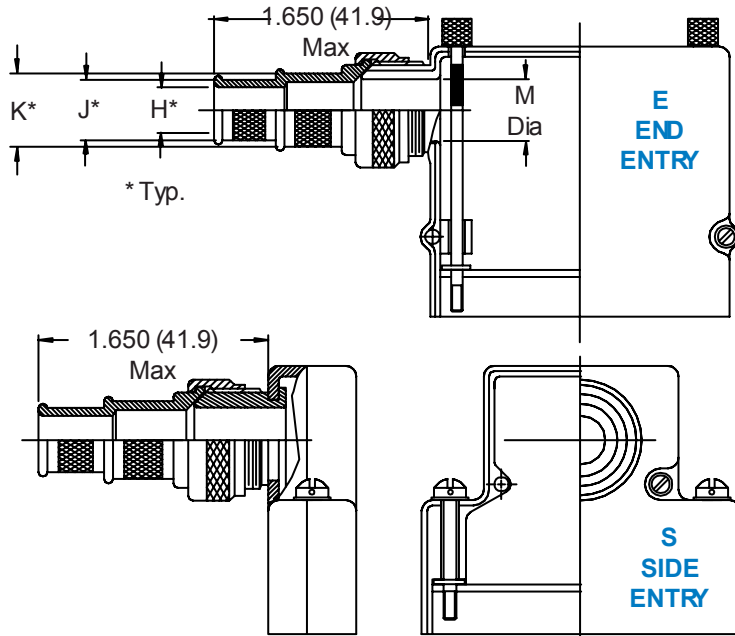
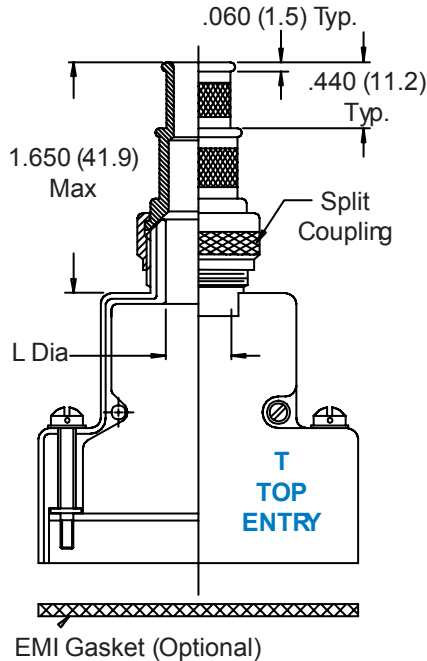
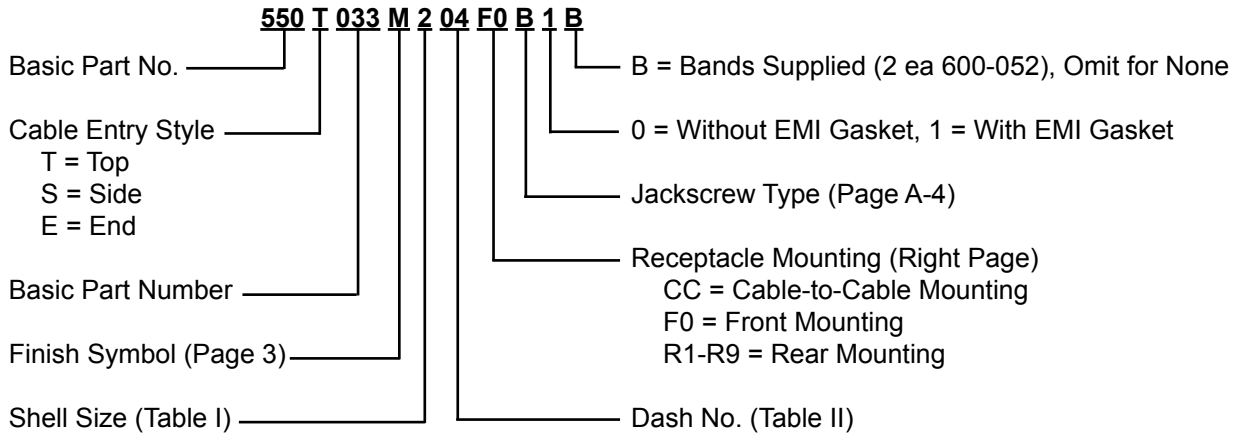

TABLE I: SHELL SIZE & ENTRY STYLE

Shell Size	Com'l Shell Size Ref	L Dia Style T Shell I.D.	M Dia Style E Shell I.D.	Max Entry Dash No.
1	E/09	.250 (6.4)	.375 (9.5)	02
2	A/15	.375 (9.5)	.375 (9.5)	04
3	B/25	.475 (12.1)	.475 (12.1)	05
4	C/37	.475 (12.1)	.475 (12.1)	05
5	D/50	.575 (14.6)	.575 (14.6)	07
6*	F/104	1.000 (25.4)	n/a	12

* Shell Size 6 Available in Top Entry Only.

TABLE II: BACKSHELL DIMS & CABLE ENTRY

Dash No.	H Dia	J Dia	K Dia
01	.125 (3.2)	.250 (6.4)	.312 (7.9)
02	.250 (6.4)	.375 (9.5)	.438 (11.1)
03	.312 (7.9)	.438 (11.1)	.500 (12.7)
04	.375 (9.5)	.500 (12.7)	.562 (14.3)
05	.438 (11.1)	.562 (14.3)	.625 (15.9)
06	.500 (12.7)	.625 (15.9)	.688 (17.5)
07	.562 (14.3)	.688 (17.5)	.750 (19.1)
08	.625 (15.9)	.750 (19.1)	.812 (20.6)
09	.687 (17.4)	.812 (20.6)	.875 (22.2)
10	.750 (19.1)	.875 (22.2)	.938 (23.8)
11	.812 (20.6)	.937 (23.8)	.969 (24.6)
12	.875 (22.2)	1.000 (25.4)	1.062 (27.0)

1. Metric dimensions (mm) are indicated in parentheses.
2. **DO NOT USE CONNECTORS WITH FLOAT MOUNTINGS.**

D-Subminiature Split Backshells Standard Dimensions

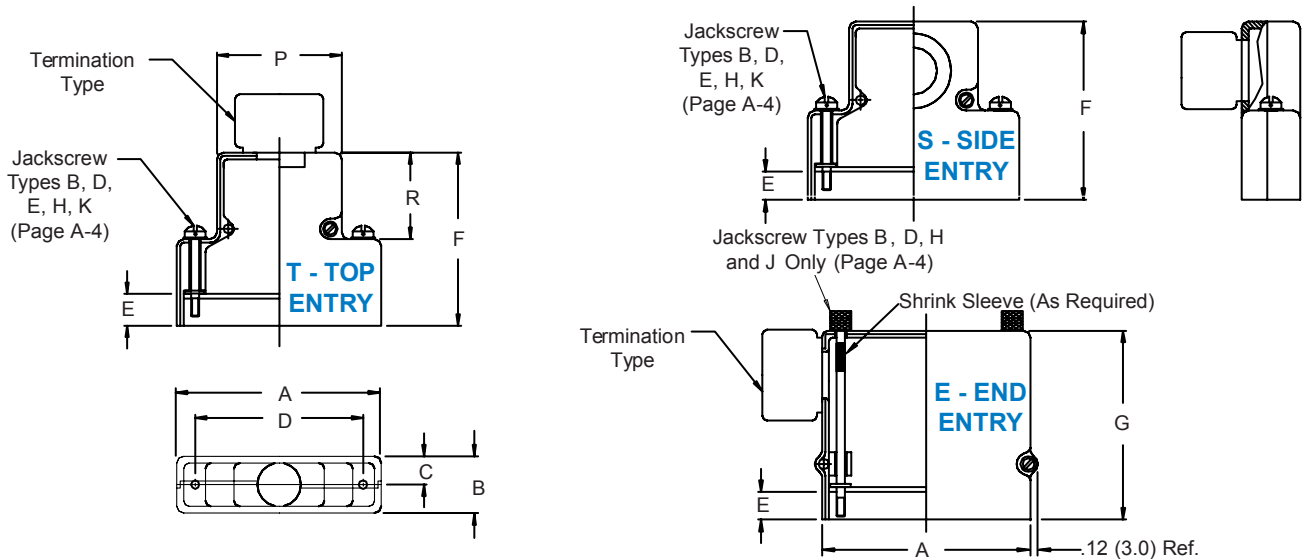

COMMON CONNECTOR/SHELL INTERFACE & BACKSHELL DIMENSIONS

Shell Size	Com'l Shell Ref	Com'l							
		A Max	B Max	C Ref.	D ±.005 (.1)	P	R Ref		
1	E/09	1.393 (35.4)	.624 (15.8)	.312 (7.9)	.984 (25.0)	.730 (18.5)	.719 (18.3)		
2	A/15	1.706 (43.3)	.624 (15.8)	.312 (7.9)	1.312 (33.3)	1.050 (26.7)	.719 (18.3)		
3	B/25	2.265 (57.5)	.624 (15.8)	.312 (7.9)	1.852 (47.0)	1.594 (40.5)	.938 (23.8)		
4	C/37	2.900 (73.7)	.624 (15.8)	.312 (7.9)	2.500 (63.5)	2.240 (56.9)	.938 (23.8)		
5	D/50	2.800 (71.1)	.750 (19.1)	.375 (9.5)	2.406 (61.1)	2.140 (54.4)	.938 (23.8)		
6	F/104	2.900 (73.7)	.844 (21.4)	.422 (10.7)	2.500 (63.5)	2.240 (56.9)	1.094 (27.8)		

CABLE MOUNTING AND BACKSHELL DIMENSIONS

Dash No.	Panel Thickness	E	F ± .031 (0.79)			G ± .031 (0.79)	
			Sizes 1 & 2	Sizes 3 - 5	Size 6	Sizes 1 & 2	Sizes 3 - 5
CC	n/a	.174 (4.4)	1.451 (36.9)	1.671 (42.4)	1.820 (46.2)	1.583 (40.2)	1.831 (46.5)
F0	n/a	.343 (8.7)	1.625 (41.3)	1.844 (46.8)	2.000 (50.8)	1.750 (44.5)	2.000 (50.8)
R1	.031 (.8)	.247 (6.3)	1.525 (38.7)	1.745 (44.3)	1.890 (48.0)	1.656 (42.1)	1.904 (48.4)
R2	.047 (1.2)	.231 (5.9)	1.509 (38.3)	1.728 (43.9)	1.875 (47.6)	1.640 (41.7)	1.888 (48.0)
R3	.062 (1.6)	.216 (5.5)	1.500 (38.1)	1.720 (43.7)	1.860 (47.2)	1.625 (41.3)	1.873 (47.6)
R4	.093 (2.4)	.185 (4.7)	1.470 (37.3)	1.690 (42.9)	1.829 (46.5)	1.594 (40.5)	1.842 (46.8)
R5	.104 (2.6)	.174 (4.4)	1.451 (36.9)	1.671 (42.4)	1.820 (46.2)	1.583 (40.2)	1.831 (46.5)
R6	.125 (3.2)	.153 (3.9)	1.430 (36.3)	1.650 (41.9)	1.798 (45.7)	1.563 (39.7)	1.811 (46.0)
R7	.156 (4.0)	.125 (3.2)	1.400 (35.6)	1.620 (41.1)	1.767 (44.9)	1.531 (38.9)	1.781 (45.2)
R8	.135 (3.4)	.140 (3.6)	1.417 (36.0)	1.637 (41.6)	1.805 (45.8)	1.550 (39.4)	1.798 (45.7)
R9	.188 (4.8)	.094 (2.4)	1.368 (34.7)	1.590 (40.4)	1.740 (44.2)	1.500 (38.1)	1.750 (44.5)

Metric dimensions (mm) are indicated in parentheses.