

Application Notes:

- Plug with screen EMC gland. RoHs compliant.
- Working voltage: 1500 Vac.
- Test voltage: 4500 Vac.
- Water proof: IP67 level (coupled connectors).
- Contact resistance: 0.3 mΩ max.
- Temperature range: -55 to +125°C.
- Contact: copper alloy silver plating.
- Insulator: UL94V0-NFF16-102:12F1 (exigency 4).
- Shell: Aluminium alloy with conductive black plating.
- Clearance in air: 26.8 mm Min.
- Creepage distance: 26.8 mm Min.

IRT Series
Rectangular Multi Pole Power Connector
 Plug Shell Size 05
 Assembly for Screen EMC Gland



IRT
Connectors

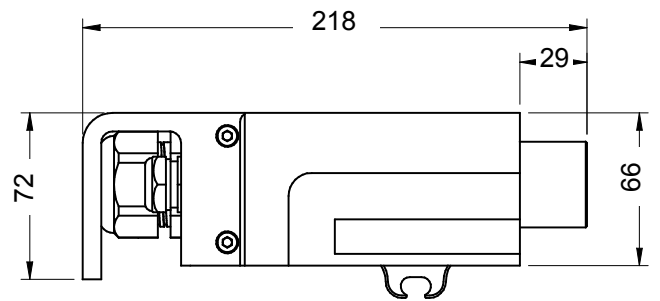
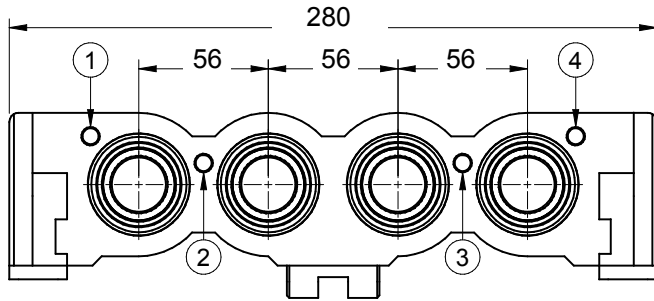

A

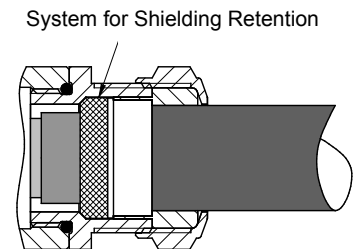
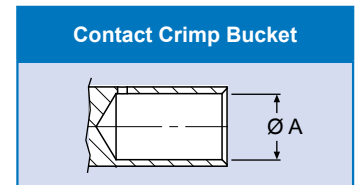
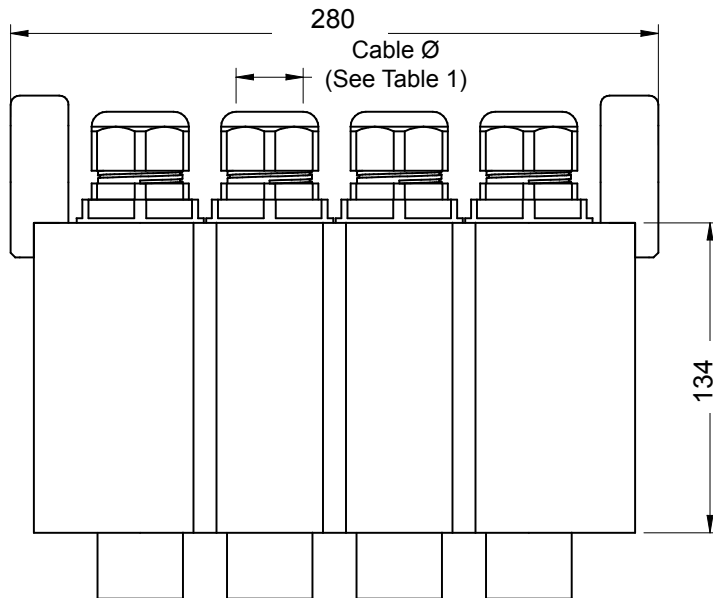

TABLE 1 - CONTACTS

Contact Type	Male Contact P/N	Female Contact P/N	Crimp Bucket - A - (mm)	Cable Section (AWG)	Cable Section (mmq)	Cable Diameter (mmq)		Working Current (A) *	Max Current (A) *
						Min	Max		
5	IRT-5-P-2200G10	IRT-5-S-2200G10	22	373MCM	185	28	32	550	600
5A	IRT-5-P-2090G10	IRT-5-S-2090G10	20.9	313MCM	150	24	28	500	550
5B	IRT-5-P-1780G10	IRT-5-S-1780G10	17.8	262MCM	120	16	19	450	520
5C	IRT-5-P-1550G10	IRT-5-S-1550G10	15.5	3/0	95	13	16	320	400
5D	IRT-5-P-900G10	IRT-5-S-900G10	9	2	35	8	11	120	150

* Related to cables section