



QwikConnect

GLEN AIR ■ APRIL 2007 ■ VOLUME 11 ■ NUMBER 2

In This Issue:

**A Strain-Relief Revolution:
The Glenair Swing-Arm
Takes To the Sky**

To Most People It's Just a Strain Relief

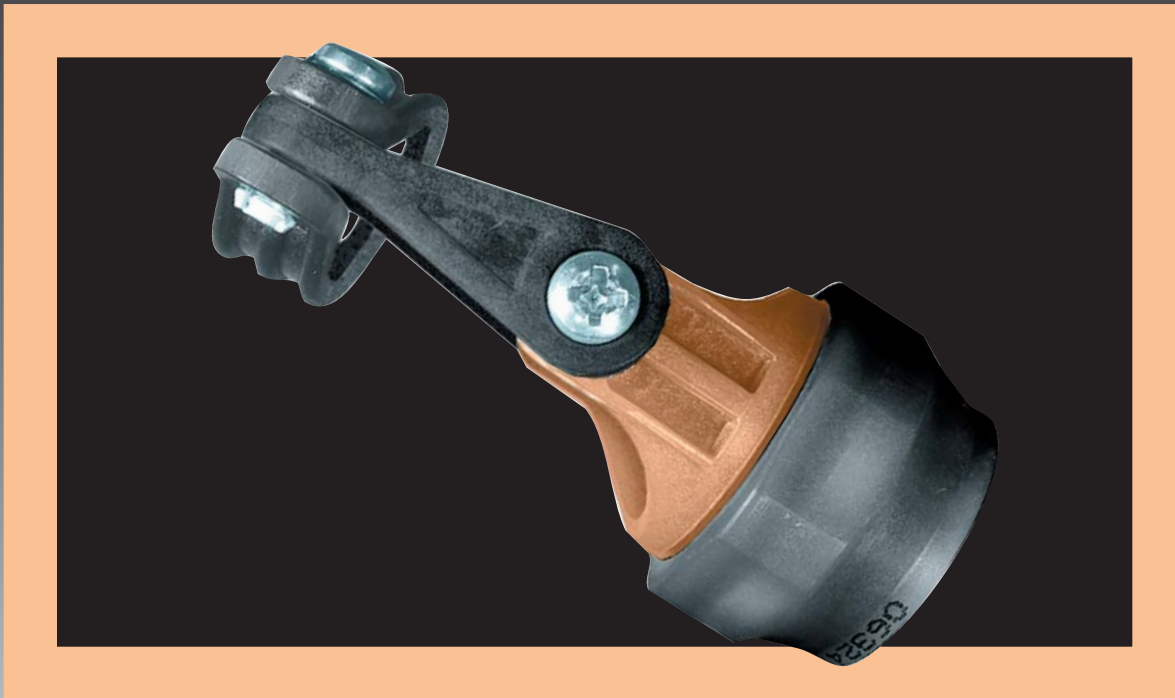

To Glenair It's a Promise

Most customers have a simple expectation when they go shopping for safety-critical interconnect components: they want fast and accurate service. Glenair addresses this most basic customer requirement in several different ways. First and foremost, by providing immediate access to our technical information and product documentation: whether you prefer an office visit, the telephone, the Internet, a CD or a printed catalog, Glenair is ready with answers to your most complex questions and design challenges. Secondly, Glenair stocks thousands of popular catalog products for those

situations when even a two or three week lead-time is just too long. We stock over 60,000 interconnect components—bagged and tagged and ready for immediate shipment. And for those situations when a customized solution is required, our engineers are fully versed in all aspects of interconnect system design: from shielding against EMI, to reducing weight and connector package size, to stopping corrosion and other forms of environmental damage.

You have a simple expectation: fast and accurate service. At Glenair, we're ready to give you exactly that. It's a promise.



1211 Air Way

Glendale, California 91201-2497

Telephone: 818-247-6000 · Facsimile: 818-500-9912 · EMail: sales@glenair.com

United States · United Kingdom · Germany · Nordic · France · Italy · Spain · Japan

www.glenair.com

Revolutions Never Turn Back, But They Sometimes Take Very Acute Angles

In the early 1990s, Glenair was tapped to solve a major problem on the F-22. Program engineers were looking to reduce the weight of interconnect cables in order to free-up weight for a package of electronic upgrades in the avionic system. Glenair was asked to design a backshell that would reduce weight by up to 50% while maintaining the strength, performance and flammability characteristics of the original metal parts. Program engineers also sought a dramatically faster method for termination of EMI shielding. Finally, they asked for a conductive part that did not require surface plating of the backshell coupling nut or body, to eliminate scratched parts that were susceptible to galvanic corrosion.

Glenair's solution to this list of requirements was nothing short of revolutionary. We designed a composite thermoplastic strain-relief with an integrated shield-sock and an internal ground ring. By design, the interlocking teeth on the internal ring created such an effective ground-path between the backshell and the connector, that there was no need to apply conductive plating to the backshell coupling nut. The choice of composite plastic answered the weight reduction requirement, and the shield-sock was a faster, easier method for EMI shield termination. More importantly, the product met all testing requirements for AS85049, including electrical resistance, vibration, and the full range of shock and strength tests. Additional F-22 testing was even more stringent, and included transfer impedance and shielding effectiveness requirements. The Glenair F-22 backshell, passed every test (relevant test reports available).

Fast forward to the year 2000, an engineer on a major airframe program presented Glenair with a new challenge: What if we don't know in advance the exact route a cable will take as it enters or exits a box or panel? He wondered how he could avoid downtime waiting for new parts once the final angle and profile was determined for each cable clamp in a harness. Ideally, he wanted to be able to reposition

the angle of the strain-relief "on the fly." He also wanted a strain-relief made of lightweight conductive materials compatible with a number of different metals yet to be specified.

This set of requirements eventually led to the development of the Glenair Swing-Arm Strain-Relief Backshell: a composite thermoplastic connector accessory based almost entirely on the 440 Series F-22 parts but with the addition of articulating arms that quickly adjust and lock into three positions—straight, 45°, and 90°. Although speed of assembly,

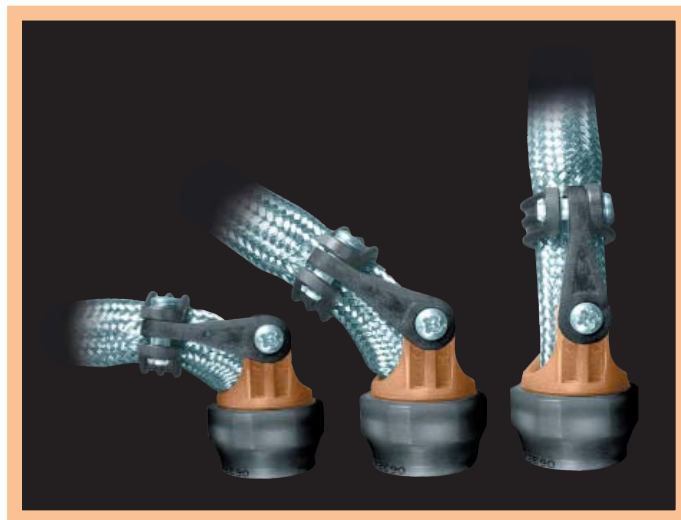

weight reduction and versatility were obvious benefits of the Swing-Arm, our launch customer soon recognized another significant advantage: the three-in-one product effectively reduced accessory inventories from 27 part numbers (three angles each for nine shell sizes) to just nine (one part for each shell size)—a major cost-saving advantage.

Since its introduction, the Glenair Swing-Arm has evolved into a number of distinct configurations and designs and has now established itself as a viable EMI/RFI shield termination device for high reliability military and commercial aerospace applications.

Special Features and Benefits of the Composite Swing-Arm EMI/RFI Strain-Relief Backshell

Glenair's patented composite Swing-Arm backshell provides lightweight and corrosion-free strain-relief for wire bundles and open loom cable assemblies. The shield-sock version of the product is also appropriate as a strain-relief and shield termination device for use with shielded, jacketed cables. When specified with its integrated shield-sock, the Swing-Arm offers extremely fast and reliable termination of EMI shields using industry-standard banding tools and bands.

Made from high-temperature composite thermoplastic, these rugged assemblies offer easy installation, long term durability, and outstanding weight and cost reduction. Standard features



Glenair is the industry leader in the innovative use of thermoplastics in high-reliability interconnect systems.

include self-locking rotatable coupling nuts, and, on shield-sock versions, a choice of integrated nickel/copper or metallized thermoplastic EMI/RFI braiding for electromagnetic compatibility. The Swing-Arm technology can also be incorporated into other EMI/RFI shield termination methods such as standard banding backshells. All versions have been performance tested to stringent AS85049 mechanical and electrical standards, as well as individual air frame test regimens, including the F-22.

We mentioned earlier that the Swing-Arm

achieves a stock-keeping economy of three-to-one, but there is more to the story. EMI/RFI Shield Sock versions actually achieve an even greater economy over traditional strain relief systems when cable entry sizes are considered. Assuming an average of five cable entry sizes for each of the nine standard connector shell sizes, stock keeping units (SKUs) for backshells drop from 135 SKUs (3 angles X 9 shell sizes X 5 cable entry sizes) to only nine backshell SKUs and a handful of support rings. This is due to the Swing-Arm's design versatility in accommodating all of the standard cable entry sizes for each connector shell size.

In addition to standard "click-style" self-locking rotatable coupling nuts, Swing-Arm is also available with Glenair-patented G-Load Coupling technology. The coupling nut spins freely without audible detents and employs a composite wave washer designed to apply locking pressure as the part is mounted to the connector. G-Load Coupling is the perfect solution for applications which require additional protection against vibration-related decoupling of the connector-to-backshell termination. Providing precise axial alignment and seating of interlocking teeth, the G-Load prevents decoupling even when backshells are installed with inadequate torque values. G-Load Couplers meet all MIL-DTL-38999 and AS85049 performance requirements at low torque: 25 inch pounds for sizes 08-19 and 35 inch pounds for sizes 20-25.

The original and most popular Swing-Arm design is made of injection-molded, high-temperature composite thermoplastic (PEI) reinforced with a 30% fill of glass fiber. The material results in a corrosion-free strain relief backshell which is 40% lighter than aluminum, 80% lighter than stainless steel, and can endure 2000+ hours salt spray. In addition to its resistance to corrosion and galvanic coupling, the thermoplastic material also provides exceptional vibration dampening and superior mechanical properties at temperatures ranging from -65° to +175° C. Fully compatible with a broad range of materials including other composites, aluminum, stainless steel, brass and more, the Swing-Arm base material is compatible with all standard finish treatments such as cadmium and electroless nickel.

Swing-Arm is made of the same composite material (PEI, 30% glass filled) used on other Glenair connector, backshell and box products. The Glenair family of composite interconnect components is the most diverse in the industry, and the PEI material used has been subjected to considerable performance testing including shock, vibration, thread strength, and bend moment requirements of AS85049, MIL-DTL-38999, MIL-STD-167, MIL-C-901D and MOD 70G Long Duration Shock. Swing-Arm has demonstrated impressive EMI/RFI, HIRF and indirect lightning strike performance in various qualification tests. As noted in the upcoming sidebar, Glenair Swing-Arm is the only backshell to pass Boeing's and the FAA's rigorous qualification testing for placement on the new 787 Dreamliner.



The Swing-Arm Strain-Relief has passed both the Boeing Company and FAA's qualification tests.

Swing-Arm can be shipped in two Shield Sock options: 36 AWG nickel-plated copper or composite thermoplastic metallized thermoplastic braiding. Nickel-plated copper braid provides excellent EMI/RFI protection with good corrosion resistance and easy grounding termination. Corrosion-free metallized thermoplastic braids offer equally easy grounding termination with performance comparable to the nickel-plated copper—and just half the weight.

The appeal of the Swing-Arm concept makes new product innovation inevitable. Glenair has already adapted the Swing-Arm concept to the requirements of our ultra-miniature connector line, the Series 80 "Mighty Mouse." Fabricated



The Glenair patented Swing-Arm Strain Relief Backshell is now available for "Mighty Mouse" style connectors. The three-in-one product enables easy straight, 90° and 45° cable routing configurations.

from aluminum alloy (or stainless steel for high temperature applications), the "Mighty Mouse" version of the Swing-Arm also uses the articulated arm system to enable straight, 45° and 90° configurations all from the same basic part. The product provides the same advantage of reduced stocking requirements, and it is considerably lighter weight than traditional miniaturized strain-relief systems.

Glenair is also introducing a new banding adapter Swing-Arm strain relief backshell which integrates the adjustable Swing-Arm technology with Band-It Shield Termination. Accommodating individual or overall shielding, the Banded Swing-Arm is the lightest weight EMI Swing-Arm design yet.

The Swing-Arm is just one of the many interconnect innovations available now from Glenair. The product not only meets the application requirements, performance benchmarks and material specifications required by the Mil-Aero marketplace, it does so while reducing overall inventory-carrying costs and assembly times. And when you figure in Glenair's customer service commitment and our Same Day inventory program, Glenair truly has all the angles covered to support this revolutionary design's adoption in hi-rel interconnect systems.

Swing-Arm has already been designed-in to a broad range of military and commercial application platforms including missile launchers, unmanned aerial vehicles and commercial and military aircraft. Even though most of Swing-Arm's applications to date have come from the aerospace industry, its utility is by no means limited to that market. Any system that requires up to three strain-relief angles in an open bundle design is ideally suited for the Swing-Arm revolution.

How Does the Glenair Swing-Arm Work?

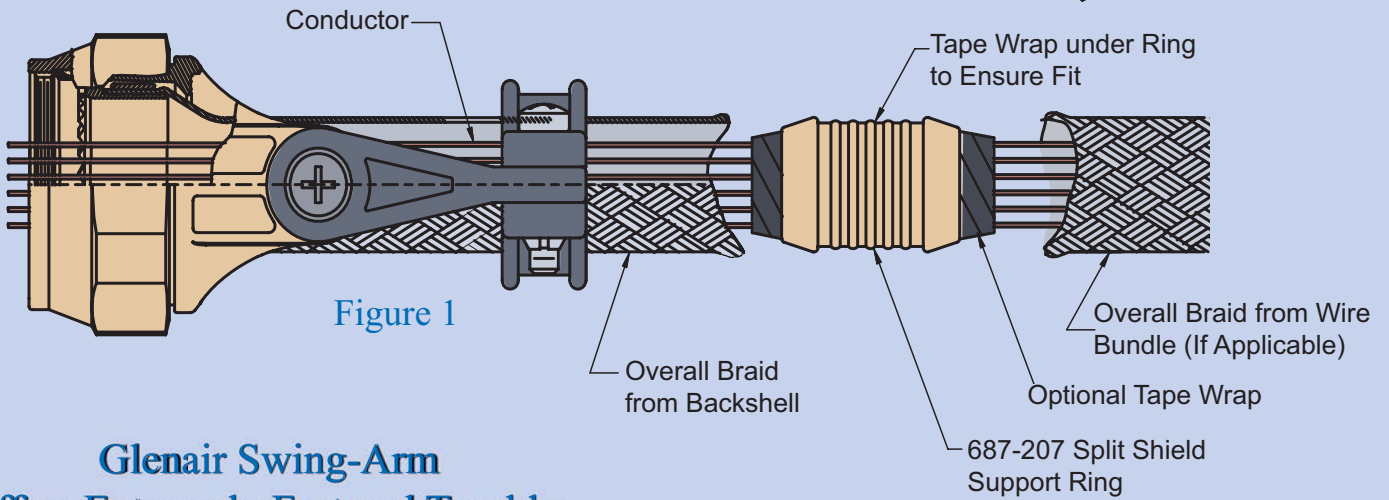
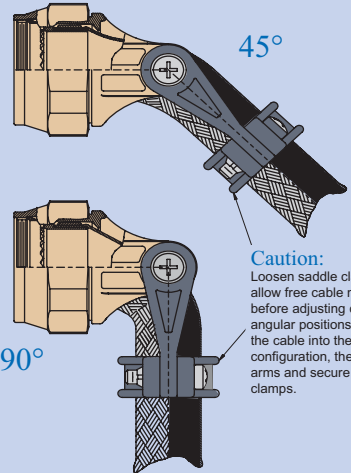

Figure 1

Glenair Swing-Arm Offers Extremely Fast and Trouble-Free Termination of EMI Shielding:

Choose Straight, 45° or 90° angle, and tighten screws to lock arms in place. Leave the saddle clamp hardware loose.

Next, insert the wire bundle into the backshell to determine if the braid transition angle from the backshell to wire bundle is less than 45°. If it is less than 45°, build up the wire bundle with tape and re-insert wire bundle into backshell to support the transition of overall braid from the backshell to the wire bundle.

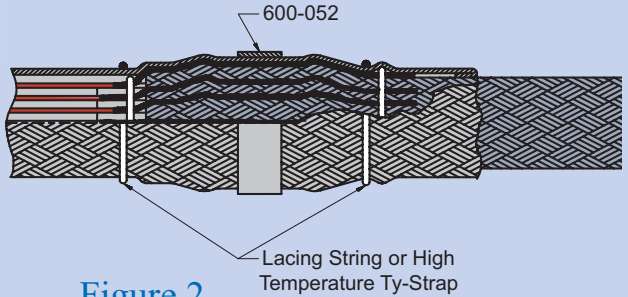

Figure 2

Note:
It is recommended that trial samples of appropriate shield wire bundles be used to determine proper trim dimensions of the cable (if applicable), and individual shields and conductors.

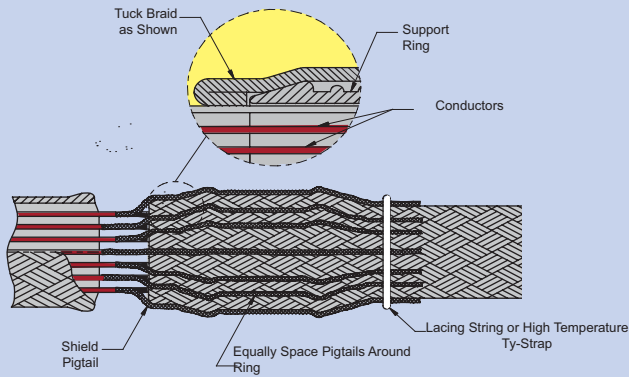

Figure 3

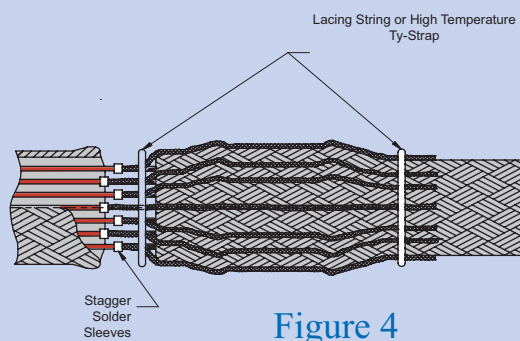

Figure 4

Loosely assemble the adapter to the connector and push back the backshell braid. Insert the wire bundle into the adapter and bottom it against the connector. Holding the cable, mark or tag the location where the shield support ring (Glenair Part Number 687-207) will be located. This distance may vary depending on your technique and the flexibility of the wire bundle immediately to the rear of the saddles (Figure 1).

At the marked location, near the shield support ring, wrap tape around wire bundle for snug fit of shield support ring (Figure 1). Tape wrap is optional.

You can then slide the overall braid from the wire bundle side over the shield support ring, trimming braid ends and tucking extra braid underneath itself for a clean appearance.

For pin connectors, slide the backshell forward, and hand tighten backshell to connector. Then, evenly space shield pigtails (Figure 3) or solder sleeve pigtails (Figure 4) around the shield support ring. Cut the pigtails so that the end of the pigtails slightly beyond end of shield support ring.

Bring the shield sock from backshell and completely cover the pigtails and support ring. Trim and fold the braid as shown in Figure 2. Lace tie the shield adjacent to support ring ends.

Install Glenair's *Band-it*[®] band (600-052) between the lace ties onto the center of the support ring as shown in Figure 2. The hand banding tool (600-058) or pneumatic banding tool (600-067) is used for this banding process.

Next, you can wrap the shield support ring assembly with high temperature tape. Place lacing cord, high temperature tape, or high temperature plastic Ty-Straps on the braid transition to the rear of the backshell to secure the overbraid on wire bundle. If you wish, you can cover the overbraid with 102-080 braid sock.

Tighten the adapter to the connector using Glenair 600-091 composite hex coupling torque wrench and related tooling accessories to established torque values. Secure the strain relief saddle onto the wire bundle using TG69 soft jaw pliers. Torque the saddle screws to established values. You can use Teflon tape wrap or M85049/127 bushing strip as needed to cushion the braid sock under the saddle clamps.

With these few steps, your Swing-Arm strain relief installation is complete!

Glenair Swing-Arm: The Sky's the Limit

The Glenair Swing-Arm Strain-Relief Backshell is ideally suited for use in avionics, data and communications systems, instrumentation, sensing systems, lighting, flap and actuator controls, landing gear, seat controllers, and in-flight entertainment systems. The Swing-Arm protects investments in connection systems while enhancing EMI/RFI shielding. Lightweight, rugged, corrosion free, and versatile, the Glenair Swing-Arm is the perfect choice to help both commercial and defense aircraft manufacturers realize their plans for unparalleled fuel efficiency, dramatic reductions in assembly times for interconnect systems, and improved stock-keeping economies.

QwikConnect would like to draw your attention to the evolution of the Swing-Arm by describing three key applications: The F-22 Raptor, the Bell Helicopter 429 and the new Boeing Company 787 Dreamliner. In the early 1990s, Glenair was tapped to solve a major problem on the F-22. Program engineers were looking to reduce the weight of backshells while maintaining the strength, performance and flammability characteristics of heavier metal parts. Although it did not yet have the articulating arm, the Series 440 Composite Shield-Sock Backshell Glenair designed for the F-22 had the same internal grounding ring with interlocking teeth for positive

Bell Helicopter adopted Swing-Arm for its new Bell 429 model. The Bell 429 is an advanced, lightweight, twin engine helicopter developed primarily for emergency medical applications. Similar to the F-22, weight reduction and performance in harsh conditions were paramount requirements for connector accessories on the Bell 429. Swing-Arm has performed so well that Bell is specifying it on additional new commercial and military programs.





Extensive qualification testing with Boeing and the FAA has established Glenair Swing-Arm's superiority—it is now fully approved and specified for accessory needs for all electrical systems. Lightweight, rugged, corrosion free, and versatile, the Glenair Swing-Arm is the perfect choice to help commercial aircraft manufacturers realize their plans for unparalleled fuel efficiency, dramatically reduced assembly time and stock-keeping economies.

contact with the connector. Because the ring accomplished complete grounding, there was no need to plate the backshell, eliminating the possibility of scratching and corrosion. Glenair Series 440 Composites met all testing requirements for F-22, including electrical resistance, vibration, half-sine shock under AS85049.

Once the articulating arm design was established, Bell Helicopter adopted Swing-Arm for its new Bell 429 model. The Bell 429 is an advanced, lightweight, twin engine helicopter developed primarily for emergency medical applications. Quite possibly the most advanced light twin helicopter ever created, the Bell 429 is both incredibly fast and incredibly light-weight—due in part to the selection of lightweight composite components throughout the aircraft. The Swing-Arm has contributed significantly to the 429's landmark performance.

The Boeing 787 Dreamliner is a mid-sized, wide body, twin engine jet airliner currently under development and scheduled to enter service in May 2008. It will carry between 210 and 330 passengers, and will be more fuel-efficient than comparable aircraft. It will also be the first major airliner to use composite material for most of its construction. Extensive qualification testing with Boeing and the FAA proved out Glenair Swing-Arm's superiority—it is now fully approved and specified for accessory needs of all electrical systems on this revolutionary aircraft.

How To Order Swing Arm Backshells

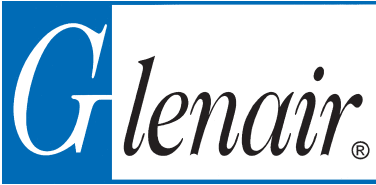

319-064
Composite Swing-Arm Strain Relief
 with ASTM-B-355 Nickel/Copper EMI/RFI Braided Shielding

U.S. PATENT NO. 6419519

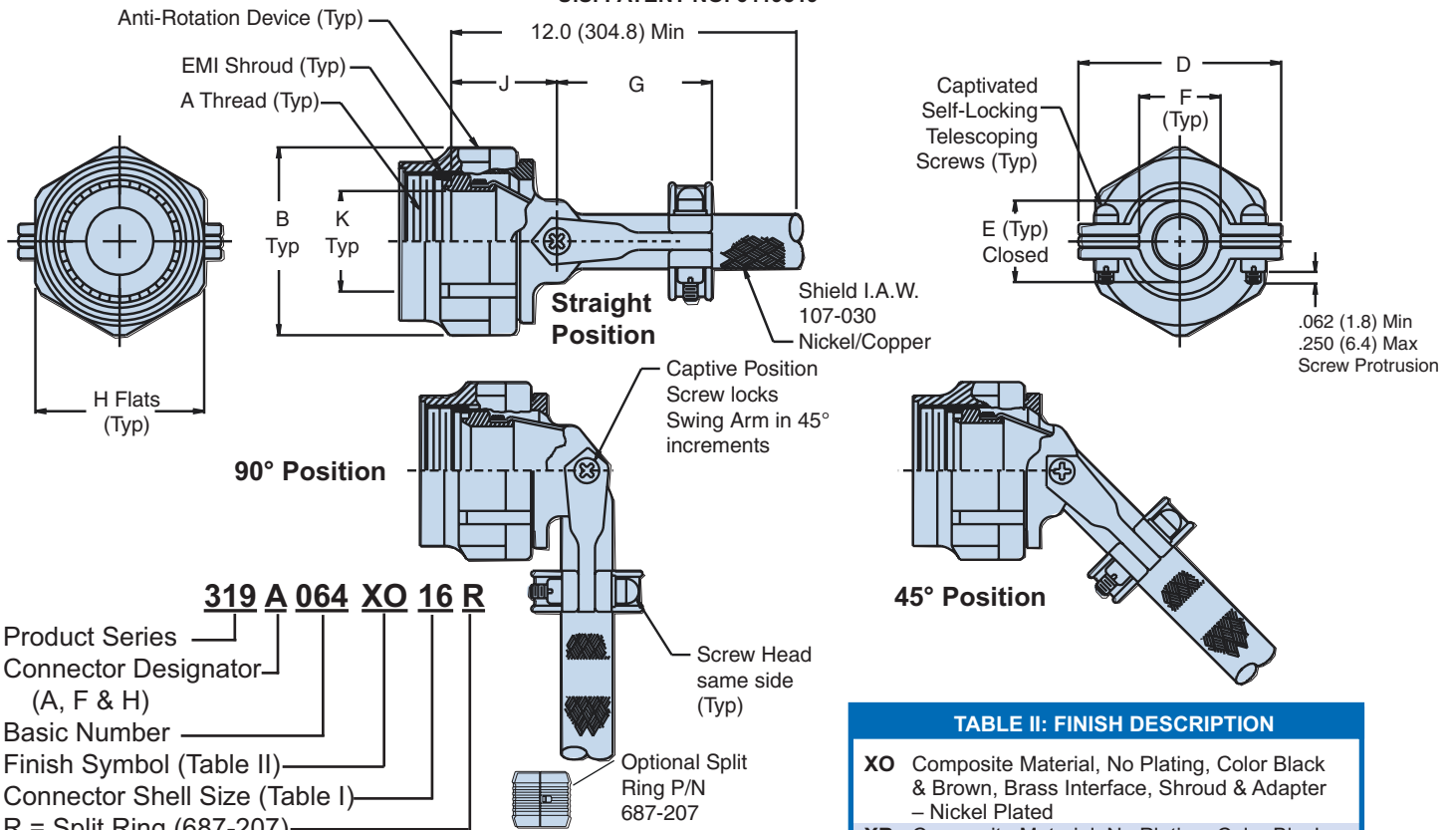

319 A 064 XO 16 R

Product Series
 Connector Designator (A, F & H)
 Basic Number
 Finish Symbol (Table II)
 Connector Shell Size (Table I)
 R = Split Ring (687-207) and Band (600-052) Supplied.
 (Omit if Not Required)

TABLE II: FINISH DESCRIPTION

- XO** Composite Material, No Plating, Color Black & Brown, Brass Interface, Shroud & Adapter – Nickel Plated
- XB** Composite Material, No Plating, Color Black, Brass Interface Shroud & Adapter – Nickel Plated
- XN** Composite Material, No Plating, Color Black & Brown, Brass Interface Shroud & Adapter – Selectively Plated Cadmium

Metric dimensions (mm) are in parentheses and are for reference

TABLE I: CONNECTOR SHELL SIZE ORDER NUMBER

Shell Size for Connector Designator			B Dia	D	E	F	G	H Flats		J	K
A	F	H	Max	Max	±.06 (1.5)	Min	Max	Max	Min	±.06 (1.5)	Ref
08	08	09	.812 (20.6)	.980 (24.9)	.265 (6.7)	.220 (5.9)	1.060 (26.9)	.750 (19.1)	.736 (18.7)	.940 (23.9)	.265 (6.7)
10	10	11	.938 (23.8)	1.050 (26.7)	.310 (7.9)	.270 (6.9)	1.090 (27.7)	.875 (22.2)	.860 (21.8)	.970 (24.6)	.370 (9.4)
12	12	13	1.125 (28.6)	1.200 (30.5)	.390 (9.9)	.350 (8.9)	1.180 (30.0)	1.000 (25.4)	.980 (24.9)	1.030 (26.2)	.506 (12.9)
14	14	15	1.250 (31.8)	1.300 (33.0)	.506 (12.9)	.470 (11.9)	1.240 (31.5)	1.125 (28.6)	1.100 (27.9)	1.090 (27.7)	.580 (14.7)
16	16	17	1.375 (34.9)	1.440 (36.6)	.591 (15.0)	.550 (14.0)	1.320 (33.5)	1.250 (31.8)	1.224 (31.1)	1.120 (28.4)	.705 (17.9)
18	18	19	1.500 (38.1)	1.560 (39.6)	.661 (16.8)	.620 (15.7)	1.390 (35.3)	1.375 (34.9)	1.469 (37.3)	1.150 (29.2)	.784 (19.9)
20	20	21	1.625 (41.3)	1.690 (42.9)	.744 (18.9)	.700 (17.8)	1.550 (39.4)	1.500 (38.1)	1.500 (38.1)	1.180 (30.0)	.909 (23.1)
22	22	23	1.750 (44.5)	1.770 (45.0)	.826 (21.0)	.780 (19.8)	1.550 (39.4)	1.625 (41.3)	1.581 (40.2)	1.250 (31.8)	1.034 (26.3)
24	24	25	1.875 (47.6)	1.890 (48.0)	.896 (22.8)	.850 (21.6)	1.610 (40.9)	1.750 (44.5)	1.960 (49.8)	1.280 (32.5)	1.149 (29.2)

Consult factory for additional entry sizes available.

How To Order Swing Arm Backshells

319-065
Composite Swing-Arm Strain Relief
 with Ultra Lightweight Metallized
 Composite Thermoplastic EMI/RFI Braided Shielding



U.S. PATENT NO. 6419519

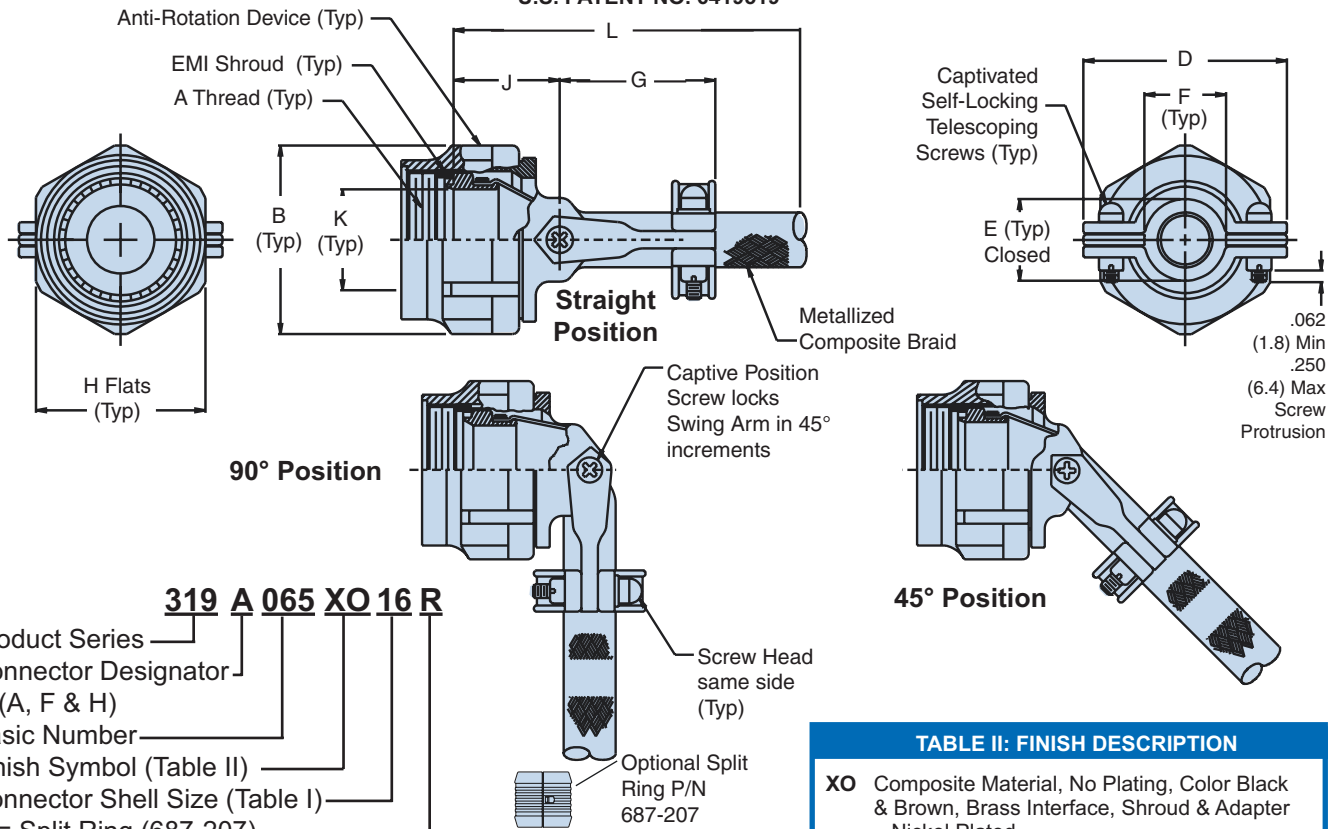

319 A 065 XO 16 R

Product Series
 Connector Designator (A, F & H)
 Basic Number
 Finish Symbol (Table II)
 Connector Shell Size (Table I)
 R = Split Ring (687-207) and Band (600-052) Supplied.
 (Omit if Not Required)

Metric dimensions (mm) are in parentheses and are for reference

TABLE II: FINISH DESCRIPTION

XO	Composite Material, No Plating, Color Black & Brown, Brass Interface, Shroud & Adapter – Nickel Plated
XB	Composite Material, No Plating, Color Black, Brass Interface Shroud & Adapter – Nickel Plated
XN	Composite Material, No Plating, Color Black & Brown, Brass Interface Shroud & Adapter – Selectively Plated Cadmium

TABLE I: CONNECTOR SHELL SIZE ORDER NUMBER

Shell Size for Connector Designator			B Dia	D	E	F	G	H Flats		J	K	L
A	F	H	Max	Max	±.06 (1.5)	Min	Max	Max	Min	±.06 (1.5)	Ref	Min
08	08	09	.812 (20.6)	.980 (24.9)	.265 (6.7)	.220 (5.9)	1.060 (26.9)	.750 (19.1)	.736 (18.7)	.940 (23.9)	.265 (6.7)	7.000 (177.8)
10	10	11	.938 (23.8)	1.050 (26.7)	.310 (7.9)	.270 (6.9)	1.090 (27.7)	.875 (22.2)	.860 (21.8)	.970 (24.6)	.370 (9.4)	7.000 (177.8)
12	12	13	1.125 (28.6)	1.200 (30.5)	.390 (9.9)	.350 (8.9)	1.180 (30.0)	1.000 (25.4)	.980 (24.9)	1.030 (26.2)	.506 (12.9)	7.000 (177.8)
14	14	15	1.250 (31.8)	1.300 (33.0)	.506 (12.9)	.470 (11.9)	1.240 (31.5)	1.125 (28.6)	1.100 (27.9)	1.090 (27.7)	.580 (14.7)	9.000 (228.6)
16	16	17	1.375 (34.9)	1.440 (36.6)	.591 (15.0)	.550 (14.0)	1.320 (33.5)	1.250 (31.8)	1.224 (31.1)	1.120 (28.4)	.705 (17.9)	11.000 (279.4)
18	18	19	1.500 (38.1)	1.560 (39.6)	.661 (16.8)	.620 (15.7)	1.390 (35.3)	1.375 (34.9)	1.469 (37.3)	1.150 (29.2)	.784 (19.9)	11.000 (279.4)
20	20	21	1.625 (41.3)	1.690 (42.9)	.744 (18.9)	.700 (17.8)	1.550 (39.4)	1.500 (38.1)	1.500 (38.1)	1.180 (30.0)	.909 (23.1)	11.000 (279.4)
22	22	23	1.750 (44.5)	1.770 (45.0)	.826 (21.0)	.780 (19.8)	1.550 (39.4)	1.625 (41.3)	1.581 (40.2)	1.250 (31.8)	1.034 (26.3)	11.000 (279.4)
24	24	25	1.875 (47.6)	1.890 (48.0)	.896 (22.8)	.850 (21.6)	1.610 (40.9)	1.750 (44.5)	1.960 (49.8)	1.280 (32.5)	1.149 (29.2)	11.000 (279.4)

Consult factory for additional entry sizes available.



627-122
Swing-Arm Strain-Relief
 for Connector Designators A, F and H

U.S. PATENT NO. 6419519

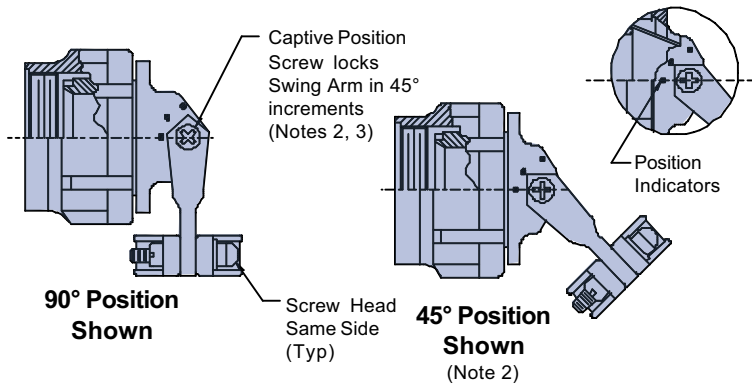
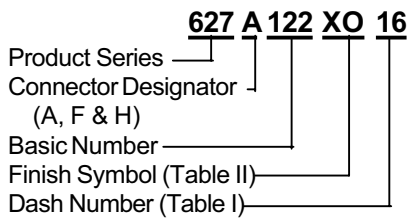
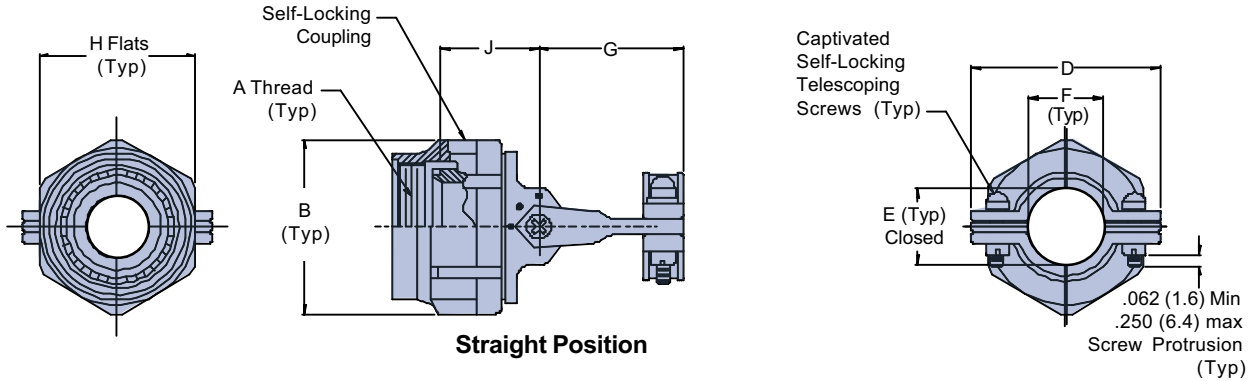

TABLE II: FINISH

XM*	Electroless Nickel
XW*	Cadmium Olive Drab Over Electroless Nickel
XO	No Plating - Base Material Non-conductive
XB	No Plating - Black Material

* Note: Coupling Nut, Saddle Bars & Arms supplied unplated.

- NOTES:**
- Glenair series 600 Backshell assembly Tools are recommended for assembly and installation.
 - Swing Arm locks in 45° increments—Sizes 08 thru 24, additional positioning increments are manufacturer's option.
 - Captive Screw can remain engaged to the body when positioning the Arm. When tightened, the Screw shall not protrude into the inside surfaces.

Metric dimensions (mm) are in parentheses and are for reference only.

TABLE I: CONNECTOR SHELL SIZE ORDER NUMBER

Shell Size for Connector Designator*			B Dia	D	E	F	G	H Flats		J
A	F	H	Max	Max	±.06 (1.5)	Min	Max	Max	Min	±.03 0.8
08	08	09	.812 (20.6)	.980 (24.9)	.265 (6.7)	.220 (5.9)	1.060 (26.9)	.750 (19.1)	.736 (18.7)	.880 (22.4)
10	10	11	.938 (23.8)	1.050 (26.7)	.310 (7.9)	.270 (6.9)	1.090 (27.7)	.875 (22.2)	.860 (21.8)	.910 (23.1)
12	12	13	1.125 (28.6)	1.200 (30.5)	.390 (9.9)	.350 (8.9)	1.180 (30.0)	1.000 (25.4)	.980 (24.9)	.950 (24.1)
14	14	15	1.250 (31.8)	1.300 (33.0)	.506 (12.9)	.470 (11.9)	1.240 (31.5)	1.125 (28.6)	1.100 (27.9)	1.010 (25.7)
16	16	17	1.375 (34.9)	1.440 (36.6)	.591 (15.0)	.550 (14.0)	1.320 (33.5)	1.250 (31.8)	1.224 (31.1)	1.050 (26.7)
18	18	19	1.500 (38.1)	1.560 (39.6)	.661 (16.8)	.620 (15.7)	1.390 (35.3)	1.375 (34.9)	1.469 (37.3)	1.080 (30.0)
20	20	21	1.625 (41.3)	1.690 (42.9)	.744 (18.9)	.700 (17.8)	1.550 (39.4)	1.500 (38.1)	1.500 (38.1)	1.120 (28.4)
22	22	23	1.750 (44.5)	1.770 (45.0)	.826 (21.0)	.780 (19.8)	1.550 (39.4)	1.625 (41.3)	1.581 (40.2)	1.160 (29.5)
24	24	25	1.875 (47.6)	1.890 (48.0)	.896 (22.8)	.850 (21.6)	1.610 (40.9)	1.750 (44.5)	1.960 (49.8)	1.200 (30.5)

Glenair Swing-Arm Same Day Inventory List

Glenair is pleased to offer our customers Same Day availability on over 60,000 connector and backshell part numbers. The following list of Swing-Arm Strain Reliefs and Accessories demonstrates our commitment to providing the interconnect industry's best service and availability for these high-reliability components. Our promise: When you design-in Swing-Arm into your commercial or military application, we will do our utmost to keep the products in stock and ready for immediate shipment.

Part Number	Description	Backshell Plating	Delivery
319F064XO08	Strain relief with nickel plated copper EMI/RFI shield sock	No Plating	1-25 pieces 1 day A.R.O.
319H064XO09R	Strain relief with nickel plated copper EMI/RFI shield sock, split ring included	No Plating	1-10 pieces 1 day A.R.O.
319H064XO11	Strain relief with nickel plated copper EMI/RFI shield sock	No Plating	1-50 pieces 1 day A.R.O.
319H064XO13	Strain relief with nickel plated copper EMI/RFI shield sock	No Plating	1-25 pieces 1 day A.R.O.
319H064XO15	Strain relief with nickel plated copper EMI/RFI shield sock	No Plating	1-10 pieces 1 day A.R.O.
319H064XO17	Strain relief with nickel plated copper EMI/RFI shield sock	No Plating	1-10 pieces 1 day A.R.O.
319H064XO19	Strain relief with nickel plated copper EMI/RFI shield sock	No Plating	1-10 pieces 1 day A.R.O.
319H064XO21	Strain relief with nickel plated copper EMI/RFI shield sock	No Plating	1-25 pieces 1 day A.R.O.
319H064XO23	Strain relief with nickel plated copper EMI/RFI shield sock	No Plating	1-25 pieces 1 day A.R.O.
319H064XO25	Strain relief with nickel plated copper EMI/RFI shield sock	No Plating	1-10 pieces 1 day A.R.O.
319A099XO24	Special strain relief with nickel plated copper EMI/RFI shield sock	No Plating	1-10 pieces 1 day A.R.O.
319H099XO09	Special strain relief with nickel plated copper EMI/RFI shield sock	No Plating	1-50 pieces 1 day A.R.O.
319H099XO11	Special strain relief with nickel plated copper EMI/RFI shield sock	No Plating	1-10 pieces 1 day A.R.O.
319H099XO13	Special strain relief with nickel plated copper EMI/RFI shield sock	No Plating	1-25 pieces 1 day A.R.O.
319H099XO15	Special strain relief with nickel plated copper EMI/RFI shield sock	No Plating	1-10 pieces 1 day A.R.O.
319H099XO17	Special strain relief with nickel plated copper EMI/RFI shield sock	No Plating	1-10 pieces 1 day A.R.O.
627H135XO09	Special strain relief: no shield sock	No Plating	1-25 pieces 1 day A.R.O.
627H135XO13	Special strain relief: no shield sock	No Plating	1-10 pieces 1 day A.R.O.
627H135XO17	Special strain relief: no shield sock	No Plating	1-10 pieces 1 day A.R.O.
627H135XO21	Special strain relief: no shield sock	No Plating	1-25 pieces 1 day A.R.O.
627H135XO23	Special strain relief: no shield sock	No Plating	1-25 pieces 1 day A.R.O.

Glenair Makes the Broadest Range of Composite Interconnect Components in the World

Swing-Arm is just one of many backshell, strain-relief products Glenair makes from lightweight, thermoplastic composite materials. Glenair has been designing and manufacturing composite connector accessories since 1986.

With hundreds of designs already tooled and ready for immediate shipment, we have more designs tooled and in stock than the rest of the interconnect accessory industry combined.

When it comes to composite connector accessories, Glenair does it all—from environmental and EMI/RFI backshells to our new G-Load Coupling and Knit Braid Backshells.

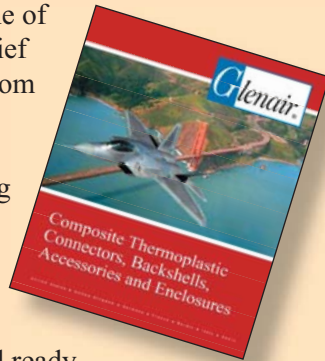

Composite Protective Covers and Stowage Receptacles

Glenair makes a full range of QPL'd composite plug and receptacle covers for 5015, 28840, 38999 and 83723 series connectors. Series 660



protective covers are critical components in interconnect systems where maintenance and test cycles can lead to damage of exposed connectors. Customers may select from split and solid ring designs equipped with rope, sash and bead style chains made from either nylon or stainless steel. Conductive and nonconductive plating options are available to match application requirements.



Composite RFI/EMI Rectangular Backshells

Glenair's line of composite rectangular backshells is the largest in the industry. Providing EMI protection for rectangular connectors used in harsh or severe operating environments, our D-Subminiature and Micro-D versions are both available in top, side and 45° entry configurations together with the full range of conductive and nonconductive finishes. All backshell designs meet the exact dimensional requirements for the specified connector series. Many styles are available from Glenair's Same Day inventory. Rectangular composite backshells include:

- Series 507 RFI/EMI Banding Backshell for MIL-DTL-83513 and Micro-D Connectors
- Series 557 RFI/EMI Banding Backshell for MIL-C-24308 and D-Subminiature Connectors

Composite Fittings for Convolted Tubing and Conduit Systems

When conduit requirements include weight reduction, electromagnetic compatibility, and corrosion-free performance, Glenair high temperature thermoplastic composites are the answer. Composite conduit fittings, including Y's, T's, panel mounts and feedthroughs, are ideally suited for use with lightweight PEEK™ plastic convoluted tubing or with other material formulas in our Series 74 tubing line.





Designed to meet stringent RFI/EMI shielding and transfer impedance requirements, Glenair's composite conduit fittings serve a wide variety of shipboard, aerospace and heavy equipment applications. Split shell designs feature tongue and groove joints. All designs are available in both plated and non-plated versions. Many composite adapters are available from our Same-Day inventory for immediate shipment.



Composite Thru-Box, Panel and Bulkhead Fittings

Glenair manufactures a full line of feed-through fittings to route wire and cable into and out of switchgear and other junction boxes. The fittings are also ideal for thru-panel and bulkhead applications. Our composite designs offer weight savings and corrosion protection. Composite feedthroughs meet RTCA/DO-160C environmental and strength requirements.



Composite Circular Backshells and Connector Accessories

Glenair has composite backshells and accessories for virtually every Mil-Spec circular connector. The products are intermatable with all qualified connector manufacturers. We offer a wide variety of plating options, couplings, and profiles. Glenair's composite accessories for circular connectors are available for immediate shipment from our huge Same-Day inventory. Selected composite backshells for circular connectors include:

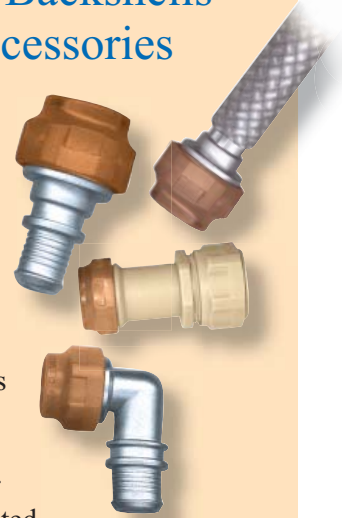

- 311 Series EMI/RFI Lamp Thread
- 319 Series Banded Shield Sock
- 380 Series EMI/RFI Cone Ring
- 380 Series Knit Braid (Westlands)
- 440 Series "Three Finger" Design
- 440 Series Banding Backshells
- 440 Series Ultra Low Profile
- 447 Series Band-in-a-Can and Other Banding Designs

Composite Connector Accessory Assembly Tools

Glenair addresses interconnect system assembly requirements with a variety of military standard and specialized connector-to-backshell assembly tools, braided shielding banding tools and accessories. Our tool line for composite components includes connector wrenches and universal connector holding tools for production use and field maintenance.

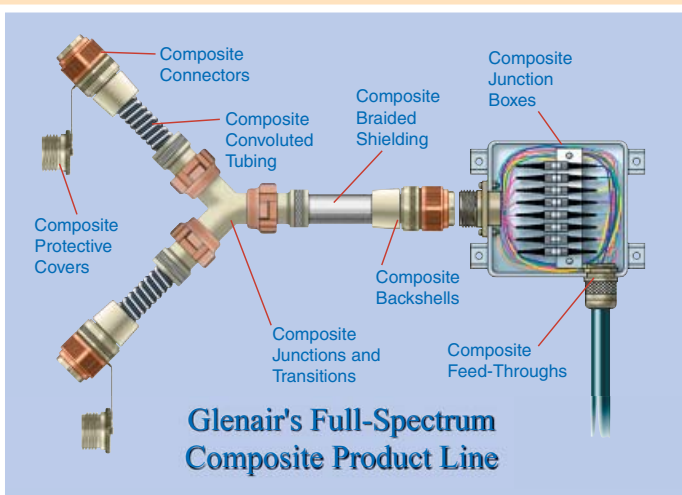

Qualification Test Report for Swing Arm Backshell

1 INTRODUCTION

1.1 Purpose

To verify compliance with all required specifications.

1.2 Scope

This report covers electrical, mechanical and environmental performance testing of Glenair Swing Arm Backshell strain relief clamps and EMI shield terminations with strain relief. The information in this report was obtained from a series of tests conducted by the test facilities in the table below. Test report documents are on file at Glenair, Glendale, California and are available upon request.

TABLE 1—TESTS CONDUCTED

Testing Agency	Location	Date	Description of Test	Document Reference
National Testing Systems	Fullerton, CA	November 11, 2005	Firewall Flame	576-4617
Lightning Technologies, Inc.	Pittsfield, MA	March 20, 2006	Indirect effects lightning	LT-06-2613
Boeing Company	Seattle, WA	April 25, 2006	Fluid Immersion, Flammability, Smoke Density & Toxicity	D022Z001-03 Rev NEW
Glenair Inc,	Glendale, CA	July 19 and July 27, 2006	Backshell Torque, GAP 027 Swing Arm Assembly Procedure, Rev 3	
Environment Associates, Inc.	Santa Ana, CA.	October 16 and November 17, 2006	Examination of Products, Magnetic Permeability, Shell Conductivity, Life Cycling, Screw Hardware Durability, Temperature Cycling, Hydrolytic stability (Composite Only), Coupling Thread Strength, Corrosion Resistance (Salt Spray), Shell Conductivity, Vibration, Shock, Shell Conductivity, External Bending Moment, Braid Retention	OC17901-1112713B, OC18631-1013308, OC18461-0713174

1.3 Conclusion

The Glenair Swing Arm Backshell strain relief clamp and EMI shield termination with strain relief have been shown to meet all required specifications.

1.4 Product Description

The Glenair Swing Arm Backshell strain relief clamp and EMI shield termination with strain relief are circular connector cable strain relief accessories intended for application on aerospace equipment, tactical military equipment, and harsh environment commercial equipment. Swing Arm products have an articulating arm that allows the backshell to quickly adjust and lock into three positions—straight, 45°, and 90°. Made of injection-molded, high temperature thermoplastic composite Ultem (PEI) reinforced with fiber glass, the Swing Arm is

available as a strain relief clamp, or in two EMI shield sock termination options: nickel-plated copper braid sock or metalized composite thermoplastic braid sock.

1.5 Test Specimens

Swing Arm Backshell strain reliefs, 627A(H)122X0 type and EMI nickel-plated copper shield termination strain reliefs, 319A(H)064XO(XN) type, in sizes small, medium and large for Groups 1, 2, 3 and 4 were used as described in table 2.

TABLE 2—TEST SPECIMEN DESCRIPTIONS

Specimen	Description
319HxxxXO11	38999 Series III, shell size 11, electroless nickel interface
319HxxxXO17	38999 Series III, shell size 17, electroless nickel interface
319HxxxXO25	38999 Series III, shell size 25, electroless nickel interface
319AxxxXN10	Shell size 10, interface I.A.W. AS85049 Figure 4A, cadmium/electroless nickel selectively plated
319AxxxXN16	Shell size 16, interface I.A.W. AS85049 Figure 4A, cadmium/electroless nickel selectively plated
319AxxxXN24	Shell size 24, interface I.A.W. AS85049 Figure 4A, cadmium/electroless nickel selectively plated
627HxxxXO11	38999 Series III, shell size 11 strain relief clamp
627HxxxXO17	38999 Series III, shell size 17 strain relief clamp
627HxxxXO25	38999 Series III, shell size 25 strain relief clamp

1.6 Test Preparation

Qualification test specimens were grouped by shell size: small size; (shell sizes 08-13), medium size; (shells sizes 14–19) and large size; (shell sizes 20 thru 28). Three (3) samples of each size group shall be tested. Small group shell size 10/11. Medium group shell size 16/17 and large group shell size 24/25 shall represent all shell sizes for purposes of this qualification. A combination of straight and 90° configured assemblies were tested.

System Test Groups 2 & 3 had the cable dead end inside the dummy test connector by sealing and tape wrapping the cable to fit snugly inside the bore (representing a wired mated connector). The assembly was wired using standard practices and Glenair’s braid sock backshell procedure GAP-027, attachment 2.

Component Test Group 4 required coupons for Flammability, Smoke & Toxicity tests. Indirect lightning strike, hydrolytic stability and fluid resistance test were performed on a complete backshell assembly.

TABLE 3—PREPARATION OF SPECIMENS

GROUP	SPECIMEN	CONNECTOR	CABLE TYPE	Solder Sleeve Pigtail
1	319H***XO**	NONE	NONE	NA
2, 3	319H***XO**	Dummy Test Connector AT44H()XM Composite / Nickel Finish	MS27500- 20SB2T23 OR EQUIVALENT	TIN
2, 3	319H***XO**	Dummy Test Connector AT441H()ZM Stainless Steel / Nickel Finish	MS27500- 20SB2T23 OR EQUIVALENT	TIN
2, 3	319A***XN**	Dummy Test Connector AT439BA()NF Aluminum/Cadmium Finish	MS27500- 20SB2T23 OR EQUIVALENT	TIN
4	HYDROLYTIC STABILITY	627H***XO**	NONE	NONE
	FLUID RESISTANCE	319H***XO**	D38999/2()M or Equivalent Mil- DTL-38999 Series III Composite Connector	NONE
	FLAMMABILITY, SMOKE AND TOXICITY	COUPONS (SAMPLES)	NONE	NONE
	INDIRECT LIGHTNING STRIKE	319H***XO**	Dummy Test Connector AT441H()ZM Stainless Steel / Nickel Finish	MS27500- 20SB2T23 OR EQUIVALENT

TABLE 4—TEST GROUPS

PRODUCT	Swing Arm Backshell EMI Shield Termination Strain Relief for MIL-DTL-38999 Series III & IV				Swing Arm Backshell EMI Shield Termination Strain Relief for I.A.W. AS85049 Figure 4A			Swing Arm Backshell Strain Relief for Series III & IV
	Group 1	Group 2	Group 3	Group 4	Group 1	Group 2	Group 3	Group 4
319HxxxXO11	2	4	2	1				
319HxxxXO17	2	4	2	1				
319HxxxXO25	2	4	1	1				
319AxxxXN10					1	1	1	
319AxxxXN16					1	1	1	
319AxxxXN24					1	2	1	
627HxxxXO11								1
627HxxxXO17								1
627HxxxXO25								1

1.7 Inspection Conditions

All tests were performed with the test specimens at standard laboratory conditions as defined below unless otherwise required by the procedure.

1. Temperature between 15° C. and 35° C.
2. Relative humidity 90% maximum.
3. Barometric pressure between 711 mm and 813 mm of mercury absolute.

1.8 Qualification Test Sequence

TABLE 5—TEST SEQUENCE

PRODUCT	Swing Arm Backshell EMI Shield Termination Strain Relief for MIL- DTL-38999 Series III & IV				Swing Arm Backshell EMI Shield Termination Strain Relief for I.A.W. AS85049 Figure 4A			Swing Arm Backshell Strain Relief for Series III & IV
	Test Group				Test Group			Test Group
TEST	1	2	3	4	1	2	3	4
	Test Sequence				Test Sequence			Test Sequence
Braid Retention	9				9			
Corrosion Resistance (salt spray)	6		4		6		4	
Coupling Thread Strength	5			2	5			2
External Bending Moment	8				8			
Flammability								6
Fluid Resistance								5
Hydrolytic Stability (composite only)				3				3
Indirect Lightning Strike								4
Life Cycling	4				4			
Magnetic Permeability	2				2			
Screw Hardware Durability		3, 10				3, 10		
Shell Conductivity	3, 7	2, 5, 9	2, 5, 7		3, 7	2, 5, 9	2, 5, 7	
Shock		7				7		7
Smoke								
Temperature Cycling		4	3			4	3	
Toxicity								8
Vibration		6				6		
Visual and mechanical examination	1, 10	1, 8	1, 6	1	1	1, 8	1, 6	1, 4

2 **SUMMARY OF QUALIFICATION TESTING**

2.1 Initial Examination of Product

All specimens submitted for testing were representative of standard production lots. All specimens were accepted by Glenair Quality Assurance prior to submittal to testing. Testing agencies visually examined specimens for mechanical damage, workmanship and markings.

2.2 Braid Retention

2.2.1 Requirement

When tested as specified, the braid shall not pull out nor shall slippage exceed .025 inch. Breakage of braid shall not be considered a failure.

2.2.2 Test Method

Backshell shall be tested for Braid Retention to a tensile load of 50 pounds minimum for shell sizes 9-16 and 100 pounds minimum for shell sizes 17-28. Backshell shall be mounted to a suitable fixture and the load shall be applied for 15 seconds minimum.

2.2.3 Results

Braid did not pull out on any of the test samples and slippage did not exceed 0.025 inch.

2.3 Corrosion Resistance (Salt Spray)

2.3.1 Requirement

Salt Spray – Component Level

When tested, backshell shield sock and interface ring shall not exhibit excessive corrosion or exposure of base material detrimental to normal operation of the backshell. Backshells without connectors or wire shall be tested to the component level tests.

Salt Spray – System Level

When tested, cable shield connection points, backshell shield sock and interface ring shall not exhibit excessive corrosion or exposure of base material detrimental to normal operation of the backshell. Backshells installed on specimens that terminate shields shall be tested to the System Level tests.

2.3.2 Test Method

Backshells shall be tested in accordance with EIA 364–026. The samples shall not be mounted, but shall be suspended from the top of the chamber using waxed twine or string, glass rods, or glass cord.

Salt Spray – Composite Backshells – Component Level

The duration of the test for unassembled backshells shall be 1000 hours.

Salt Spray – System Level

Backshells shall be assembled to connectors with shielded wire terminated to Shield Sock. Test sample sizes shall be configured as shown in Figure 1 in Section 2.52 below. The duration of the test shall be 500 hours.

2.3.3 Results

No excessive corrosion or exposure of base material detrimental to normal operation of the test samples.

2.4 Coupling Thread Strength

2.4.1 Requirement

When tested, backshell coupling threads shall withstand the torque specified without damage. The coupling threads shall be inspected with 3 times magnification for damage

2.4.2 Test Method

A counterpart connector or dummy connector shall be mounted in a suitable fixture. The backshell shall be threaded onto the fixture and a torque wrench used to apply the coupling thread strength torque as indicated in the table below at a rate of approximately 10 inch pounds per second. The required load shall be held for one minute minimum.

TABLE 6—COUPLING THREAD STRENGTH

Shell Size	Coupling Installation Torque ± 5 Inch Pounds		Coupling Thread Strength ± 5 Inch Pounds	
	Composite	Steel	Composite	Steel
8 thru 11	35	85	45	100
12 thru 19	40	120	50	150
20 thru 28	80	165	100	200

2.4.3 Results

Test samples were subjected to visual examination with 3X magnification. There was no visible evidence of physical damage noted.

2.5 External Bending Moment

2.5.1 Requirement

When tested, the backshells shall show no evidence of damage detrimental to their normal operation.

2.5.2 Test Method

The backshell shall be mounted to a receptacle or plug as required. A dummy receptacle or fixture simulating a mated connector pair may be used to perform the test. The receptacle or fixture shall be mounted to a rigid surface so as to resist deflection. A load shall be applied to the backshell in two axes 90 degrees apart as shown in Figure 1 below. The load shall be as indicated in the table below and shall be applied at a rate of approximately 10 pounds per second until the required load is achieved. The applied load shall be held for 1 minute.

TABLE 7—EXTERNAL BENDING MOMENT LOAD

Shell Size	Load (pounds min)	
	Straight	90 Degree
8 and 9	15	20
10 and 11	25	30
12 and 13	25	30
14 and 15	30	40
16 and 17	40	50
18 and 19	40	50
20 and 21	40	50
22 and 23	40	50
24 and 25	50	50
28	50	60

FIGURE 1—EXTERNAL BENDING MOMENT

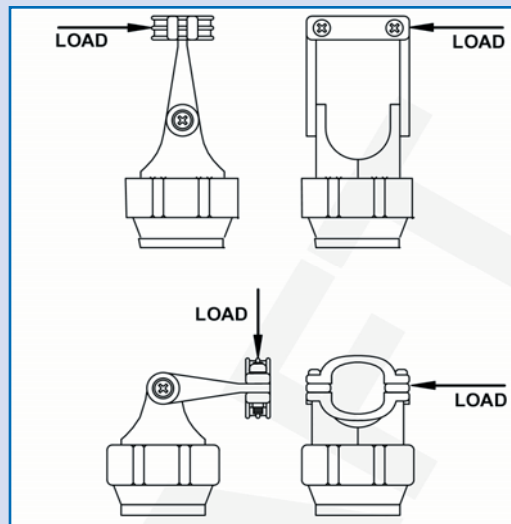

2.5.3 Results

No visible damage to the normal operation of the test samples noted.

2.6 Flammability

2.6.1 Requirement

Materials used in items covered by this specification shall be materials that do not sustain combustion when tested as specified.

2.6.2 Test Method

Non-metallic materials considered for use in items covered by this specification shall be tested under the 12-second ignition, vertical, method.

2.6.3 Results

Backshells passed test requirements as shown below.

TABLE 8—FLAMMABILITY TEST RESULTS

Sample No.	Exiting Time (secs)		Burned Length (inches)		Drip Exiting Time (secs)	
	Max Allowed	Actual	Max Allowed	Actual	Max Allowed	Actual
1	15	0	8	0.4	5	No Drip
2	15	0	8	0.2	5	No Drip
3	15	0	8	0.4	5	No Drip
Average	15	0	8	0.3	5	0

2.7 Fluid Resistance

2.7.1 Requirement

When tested, the test sample shall show no evidence of damage that will affect performance. Any evidence of cracking, loosening of parts or missing parts shall be cause for rejection.

2.7.2 Test Method

The test shall be performed in accordance with EIA-364, Test Procedure 10, using the fluids defined in the Table below.

TABLE 9—TEST FLUIDS

Test Fluid	Test Cycle (Times ± 10 percent)					Number Of Cycles
	Test Fluid Temperature		Drainage Time	Oven Cure, Mated		
	Temp ± 3 C	Time Minutes	Free Air Hours	Time Hours	Temp ± 3 C	
BMS 3-11 Type IV, Class 1 Hydraulic Fluid, Fire Resistant	70	5	1	6	100	7
Isopropyl Alcohol, TT-I-735	23	5	24	---	---	5
Methyl Propyl Ketone, BMS11-9, Grade 1	23	5	1	---	---	7
Anti-Icing Fluid	23	60	1	6	100	7
Lubricating Oil, MIL-PRF-23699	120	5	1	6	125	7
Alkaline Detergent, pH 10.0-10.5	23	5	1	6	100	7
Fuel Jet A, ASTM D 1655	23	5	1	6	55	7
Hydraulic Fluid, MIL-PRF-5606	70	5	1	6	100	7
Hydraulic Fluid, MIL-PRF-87257	70	5	1	6	100	7
Dow frost 60 Heat transfer Fluid	23	5	1	6	100	7
Potassium Formate Runway De-icer	23	5	1	6	55	7

2.7.3 Results

Backshells meet the requirements, except as noted in 2.74 below, of the fluid immersion qualification test for composite connectors and backshells.

2.7.4 Exceptions

The backshells were visually examined per the final examination requirements in section 4.2, D022Z001-01 and section 7.0, Z43S0-WAB. 5X magnification maximum was allowed during the final examination.

The following visual observations were noted: Test article #01, which was soaked in BMS 3-11, type IV, class 1 hydraulic fluid, fire resistant, was missing the part number and date code that was stamped on each of the backshells.

On test article #04, which was soaked in heat transfer fluid, Dow Frost 60, the backshell from the receptacle connector side appears to have a crack around the tightening portion. It was determined that the backshell had cracked before testing. Therefore a new backshell was used to retest the Dow Frost 60 fluid. The retest passed all requirements.

2.8 Hydrolytic Stability (composite only)

2.8.1 Requirement

When tested, there shall be no increase in weight greater than 5 percent. Backshells shall meet the coupling thread strength requirements.

2.8.2 Test Method

Composite backshells shall be tested for water absorption in accordance with ASTM D 570, paragraph 7.4, long term immersion.

2.8.3 Results

All samples met coupling strength requirements. The average two-week weight gain for all samples was less than 1%

2.9 Indirect Lightning Strike

2.9.1 Requirement

The objective of this test is to ensure that the composite backshell does not show any evidence of damage that would prevent proper functioning of the connector assembly. Backshells shall be tested for the ability to conduct indirect lightning currents through the metallic finish without damaging the base materials or causing the metallic finish to blister or char. The parts should be visually inspected for any damage to the metallic plating. There shall be no evidence of blistering or charring. The backshell shall also be inspected to ensure that the thermoplastic material was not damaged by the thermal energy developed during testing.

2.9.2 Test Method

The backshell shall be tested as specified per EIA-364-75, Waveform 5B for the ability to conduct lightning currents except as follows:

Time T1 shall be 50 μ sec +20 percent
Time T2 shall be 500 μ sec +20 percent

Test level shall be 6,000 Amps. Ten positive polarity transients shall be applied followed by ten negative polarity transients. The time between individual transients is not critical. All transients shall be applied at the applicable peak amplitude level.

2.9.3 Results

No sign of physical damage to the connector was observed after completion of the lightning tests. Bonding resistance decreased after transients had been applied to the connector.

2.10 Life Cycling

2.10.1 Requirement

After being subjected to the test specified, backshells shall pass succeeding tests. The Backshells shall show no evidence of damage detrimental to normal operation.

2.10.2 Test Method

Backshells shall be coupled and uncoupled from their connectors 10 cycles at coupling thread strength torque followed by 10 cycles at coupling installation torque as shown in Table 10.

2.10.3 Results

All samples passed test requirements as indicated in the table below.

TABLE 10—LIFE CYCLING RESULTS

Part Number	Coupling Thread Strength ± 5 inch pound	Coupling Installation Torque ± 5 inch pound	Result
319HxxxXO11	45	35	PASSED
319HxxxXO11	45	35	PASSED
319HxxxXO17	50	45	PASSED
319HxxxXO17	50	45	PASSED
319HxxxXO25	100	80	PASSED
319HxxxXO25	100	80	PASSED
319AxxxXN10	45	35	PASSED
319AxxxXN16	50	45	PASSED
319AxxxXN24	100	80	PASSED

2.11 Magnetic Permeability

2.11.1 Requirement

When tested as specified, the relative permeability of the backshell shall be less than 2.0Mu for composite and less than 5.0Mu for stainless steel.

2.11.2 Test Method

The relative permeability shall be tested in accordance with EIA 364–54.

2.11.3 Results

All samples met the test requirements.

2.12 Screw Hardware Durability

2.12.1 Requirements

The locking capability values recorded of the saddle nuts and swing arm pivot nuts shall not be greater than the maximum locking torque nor less than the minimum breakaway torque

specified in the table below. The backshells shall show no evidence of damage detrimental to normal operation.

TABLE 11—SELF LOCKING NUT TORQUE

Screw Size	Maximum Locking Torque (inch pounds)	Minimum Breakaway Torque (inch pounds)
4	5	0.5
6	10	1.0
8	15	1.5
10	18	2.0

2.12.2 Test Method

The saddle clamp screws and the swing arm pivot screws shall be installed into and removed from their respective nuts 15 times. Parts were retested following six additional test procedures.

2.12.3 Results

Samples were visually examined following the initial and subsequent tests. There was no visible evidence of damage detrimental to normal operation of the test samples.

2.13 Shell Conductivity

2.13.1 Requirements

Shell Conductivity – Component Level

When tested as specified, the resistance between the backshell shield sock and the connector shall not exceed 2.5 milliohm for composite backshells and 5.0 milliohm for stainless steel backshells.

Shell Conductivity – System Level

When tested as specified, the resistance between the cable shield and the connector shall be measured, recorded, and submitted in the qualification test report.

2.13.2 Test Method

Shell conductivity shall be measured with an applied potential of 1.5 volts maximum. A resistance shall be in series with the test circuit to limit the current to .100 ampere +.010. Measurement locations are shown in the figure, “Test Measurement Points” below. For the component level test, measurements shall be made from the shield sock to the connector shell. For the system level test, measurements shall be made from the cable shield or cable shield pigtail to the connector shell as shown in the figure below. Samples are tested twice or three times within the test sequence of each group 1, 2, and 3.

FIGURE 2—TEST MEASUREMENT POINTS

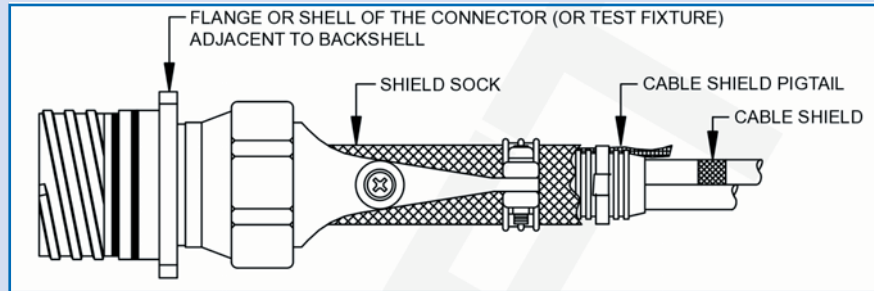

2.13.3 Results

Shell conductivity was less than 2.5 mΩ on all test samples.

On the third retest of Group 2, two backshells failed as a result of a technician repositioning the swing arms without loosening clamp saddle screws. Glenair added a notation to the relevant assembly procedures to caution that saddle clamp screws must be loosened prior to repositioning.

2.14 Shock

2.14.1 Requirements

When tested as specified, backshells shall not be damaged, nor should there be any loosening of parts.

2.14.1.1 Test Method

A counterpart receptacle connector, mounted on a suitable fixture, shall be attached to the shock machine. The wired mating plug connector and backshell shall be engaged to the receptacle connector by normal locking means. The cable shall be clamped to a fixed point at least 8 inches from the rear of the backshell. The assembly shall be subjected to the shock test requirements of EIA 364–27, Condition C, calling for 3 shocks in the positive direction, 3 shocks in the negative direction, repeated in each of three axes for a total of 18 shocks per specimen. Monitoring for discontinuity is not required.

2.14.2 Results

Samples passed the requirements of EIA 364-27, Condition C with no anomalies noted.

2.15 Smoke

2.15.1 Requirements

Materials used in items covered by this specification, when tested in accordance with ASTM F814-83, shall not emit smoke having Specific Optical Density (DS) of 200 or more, as specified.

2.15.2 Test Method

ASTM F814-83

2.15.3 Results

Average results below show no emissions of smoke density at or above Specific Optical Density (DS) of 200.

TABLE 12—SPECIFIC OPTICAL DENSITY (DS)

Specimen Number	----- Minutes -----						Max in 1st 4 min	Time of Maximum
	1:00	1:50	2:00	3:00	4:00	5:00		
1	0.10	0.74	1.72	6.62	15.38	32.74	15.38	4.00
2	0.73	0.92	1.63	3.07	5.45	8.75	5.45	4.00
3	0.24	0.73	1.25	2.98	5.97	12	5.97	4.00
AVG:	0.36	0.80	1.53	4.22	8.93	17.67	8.93	4.00
Sid Dev	0.33	0.11	0.25	2.07	5.59	13.12	5.59	

2.16 Temperature Cycling (composite only)

2.16.1 Requirements

When tested as specified, there shall be no blistering, peeling, or separation of plating, or other damage detrimental to the normal operation of the backshell.

2.16.2 Test Method

Composite backshells shall be tested in accordance with EIA 364–32, Condition I, 5 cycles, except that steps 2 and 4 shall be of 2 minutes maximum duration. The temperature of step 1 shall be -65 ± 0 , -5 degrees C and the temperature of step 3 shall be 200 ± 5 , -0 degrees C.

2.16.3 Results

Samples were visually examined following tests. There was no visible evidence of damage detrimental to normal operation of the test samples.

2.17 Toxicity

2.17.1 Requirements

Materials used in backshells or other parts covered by this specification shall liberate only non-toxic fumes when tested as specified. The average value of toxic gas emissions in parts per million (PPM) after four minutes shall not exceed the values indicted in 2.17.3 below:

2.17.2 Test Method

Ion chromatography as specified.

2.17.3 Results

TABLE 13—TOXICITY RESULTS

Component	Maximum Allowed (PPM)	Actual (PPM)
HCN	150	2.0
HF	200	1.0
HCL	500	1.0
SO ₂	100	-
NO _x	100	-

2.18 Vibration

2.18.1 Requirements

When tested as specified, the test sample shall show no evidence of damage that will affect performance. Any evidence of cracking, loosening of parts or missing parts shall be cause for rejection. Monitoring for electrical continuity shall not be used for pass/fail criteria.

2.18.2 Test Method

The backshell shall be tested in accordance with EIA 364–28, Condition VI, test condition letter I (AS85049 Medium Duty). The duration of the test shall be 8 hours in the longitudinal direction and 8 hours in the perpendicular direction. Parts were tested at maximum installed torque and recommended torque values.

TABLE 14—VIBRATION RESULTS

Part Number	Sample No.	Minimum (recommended) Torque Value	Maximum Torque Value	Result
319HxxxXO11	001		35	PASSED
319HxxxXO11	002		35	PASSED
319HxxxXO11	13A	25		PASSED
319HxxxXO11	14A	25		PASSED
319HxxxXO17	006		45	PASSED
319HxxxXO17	007		45	PASSED
319HxxxXO17	15A	30		PASSED
319HxxxXO17	16A	30		PASSED
319HxxxXO25	008		80	PASSED
319HxxxXO25	009		80	PASSED
319HxxxXO25	17A	35		PASSED
319HxxxXO25	18A	35		PASSED
319AxxxXN10	022		35	PASSED
319AxxxXN16	021		45	PASSED
319AxxxXN24	020		80	PASSED
319AxxxXN24	023		80	PASSED

2.18.3 Results

Samples met the requirements of EIA 364-28, Condition VI, at maximum installed torque and recommended torque values, with no anomalies noted.

2.19 Visual and mechanical examination

2.19.1 Requirements

Backshells shall be examined as specified.

2.19.2 Test Method

Backshells shall be examined to ensure conformance with all requirements of this specification and the applicable detail documents. Examination shall be performed to ensure compliance with dimensions, materials, and identification markings.

2.19.3 Results

Observations are shown in table below. Markings on all test samples were legible. Note that Group 3 samples were subjected to 500 hours salt spray prior to visual inspection.

TABLE 15—VISUAL AND MECHANICAL EXAMINATION RESULTS

Part Number	Group	Sample No.	Observations
319HxxxXO11	1	011	None
319HxxxXO11	1	012	Minor stains (after salt spray)
319HxxxXO17	1	013	None
319HxxxXO17	1	014	Minor stains (after salt spray)
319HxxxXO25	1	015	Traces of stains (after salt spray)
319HxxxXO25	1	016	Minor stains (after salt spray)
319AxxxXN10	1	017	Traces of stains—white deposit on mating receptacle (after salt spray)
319AxxxXN16	1	018	Minor stains (after salt spray)
319AxxxXN24	1	019	Minor stains—some exposure of base metal on mating receptacle (after salt spray)
319HxxxXO11	2	001	None
319HxxxXO11	2	002	None
319HxxxXO17	2	006	None
319HxxxXO17	2	007	Swing Arm screw loose due to ultra sonic insert fastening to the arm. Testing anomaly.
319HxxxXO25	2	008	None
319HxxxXO25	2	009	None
319AxxxXN24	2	020	Shield sock separated from coupling ring due to test technician repositioning Swing Arm without loosening saddle screw.
319AxxxXN16	2	021	None
319AxxxXN10	2	022	None
319AxxxXN24	2	023	Swing Arm screw insert loose. Partial separation of shield sock from coupling ring. Both due to ultra sonic insert fastening to the arm. Testing anomaly.
319HxxxXO25	3	01A	Minor corrosion of pivot arm and clamp screws.
319AxxxXN16	3	02A	Minor corrosion of pivot arm and clamp screws.
319AxxxXN10	3	03A	Minor corrosion of pivot arm and clamp screws.
319HxxxXO11	3	003	Minor discoloration of saddle clamp screws. Shield sock & mating shell show minor stains.
319HxxxXO17	3	005	Minor discoloration of Swing Arm screws and saddle clamp screws. Shell discolored.
319AxxxXN24	3	010	Stains on Swing Arm and saddle clamp screws.
319HxxxXO11	3	028	Minor discoloration of saddle clamp screws. Shield sock stained, minor stains on mating shell.

Part Number	Group	Sample No.	Observations
319HxxxXO17	3	029	Stain on Swing Arm screws. Mating shell discolored. Minor discoloration on shield sock.
319HxxxXO25	3	030	Swing Arm screws and saddle clamp screws discolored. Some local deposit (evidence of leaching) near coupling nut. Mating shell discolored.

Innovation and Distribution

As this edition of *QwikConnect* demonstrates, our Series 319 and 627 Swing-Arm is catching on nicely with our OEM customers, and we have highlighted several applications in which the Swing-Arm is providing OEM's with both superior technical performance as well as better overall value in hi-rel interconnect assemblies. In fact, the Swing-Arm has become popular enough with OEM's that it is now being stocked in our distribution channel—a gratifying development, particularly since these are non-Mil-Spec products.

Our M85049 Backshells and other QPL'd interconnect products have long been a staple within our distribution network. Glenair M83513 Micro-D Connectors, for example, are big sellers via distribution. Obviously it is easier for distributors to forecast usage levels of products that are widely applied throughout the industry. Equally obvious, Mil-Spec qualifications provide distributors with a virtual guarantee that the products are ready for prime-time use in hi-rel interconnect applications. So we are encouraged that our distribution partners share our view that non-Mil-Spec products that solve significant problems—such as weight reduction, corrosion protection and part-number reduction—can compete in the Mil-Aero marketplace.

Glenair works hard to be a good partner to our franchise distributors. Our entire product range is available to distributors—from banding backshells to fiber optic connectors and termini; from hermetic connectors to EMI/EMP filters; from Swing-Arm strain reliefs to our Series 80 "Mighty Mouse" Connector line. Our same day inventory and no-minimum order policy allows distributors to offer exceptional turn-around to their customers. We also offer distributors a wealth of personalized service and support which in turn helps them improve their customer service offerings.

Distribution is such an important channel to market for Glenair that we actively promote cooperation between our own field sales offices and our authorized distributors. There are no disincentives in place that might cause a sales group to disdain a distributor as "the competition." To the contrary, there are many incentives in place for sales groups to work closely with distributors to provide the best possible support to OEM customers. We know that distributors provide an important service to OEM's, who purchase an incredibly broad range of products and appreciate the special terms and one-stop-shopping that distributors offer.

We appreciate and value our authorized distributors and are pleased to have them represent Glenair in the Mil-Aero marketplace. We are doubly pleased to have our distributor partners offer our full range of high-reliability interconnect products—from our more standard Mil-Spec products to our most innovative interconnection solutions.



President
Glenair, Inc.

Publisher

Christopher J. Toomey

Executive Editor

Marcus Kaufman

Managing Editor

Carl Foote

Editor/Art Director

Charles W. Belser

Issue Contributors

Mike Wofford

Jim Plessas

Tom Young

Photographs

Jim Donaldson

Distribution

Terry White

Glenair has been the leading manufacturer and supplier of commercial and Mil-Spec connector accessories since 1956. Building on that foundation, we now offer a dozen, full-spectrum product lines designed to meet every interconnect requirement. From ruggedized military connectors to tactical fiber optic connectors and cables, from EMI conduit systems to Micro-D harness assemblies, from Navy approved composite enclosures to a complete range of connector assembly tools—Glenair does it all. And throughout the years, we've made outstanding customer service our approach to earning customer trust, and to maintaining our position as the industry's best-value interconnect supplier. *QwikConnect* is published occasionally by Glenair, Inc. Printed in U.S.A. All rights reserved. © Copyright 2007 Glenair, Inc.



GLENAIR, INC.

1211 AIR WAY
GLENDALE, CA 91201-2497
TEL: 818-247-6000
FAX: 818-500-9912
EMAIL: sales@glenair.com
www.glenair.com