

# AS85049/85, AS85049/86 and AS85049/87 Straight, 45° and 90° Banding Backshells with Self-Locking Coupling



AS85049

B

<b>CONNECTOR DESIGNATOR:</b>	
<b>F</b>	MIL-DTL-38999 Series I and II

<b>Basic Part Number</b> <i>M85049/85 = Straight</i> <i>M85049/86 = 45°</i> <i>M85049/87 = 90°</i>	<i>— = Detented</i> <i>N = Non-Detented</i>	<b>Shell Size</b> (Table I)	<b>Entry Size</b> (Tables II and III)
<b>M85049/85</b>	<b>N</b>	<b>16</b>	<b>P</b>
			<b>02</b>

Finish	
<i>N</i>	Electroless Nickel
<i>P</i>	Cadmium, Olive Drab over Electroless Nickel with Polysulfide Sealant Strips
<i>W</i>	1,000 Hr. Cadmium Olive Drab over Electroless Nickel
<i>X</i>	Aluminum, Nickel Fluorocarbon Polymer
<i>YP</i>	Aluminum, Pure Dense Electrodeposited Aluminum with Polysulfide Sealant Strips
<i>Z</i>	Aluminum, Zinc-Nickel, Black
<i>ZP</i>	Aluminum, Zinc Nickel with Polysulphide Sealant Strips

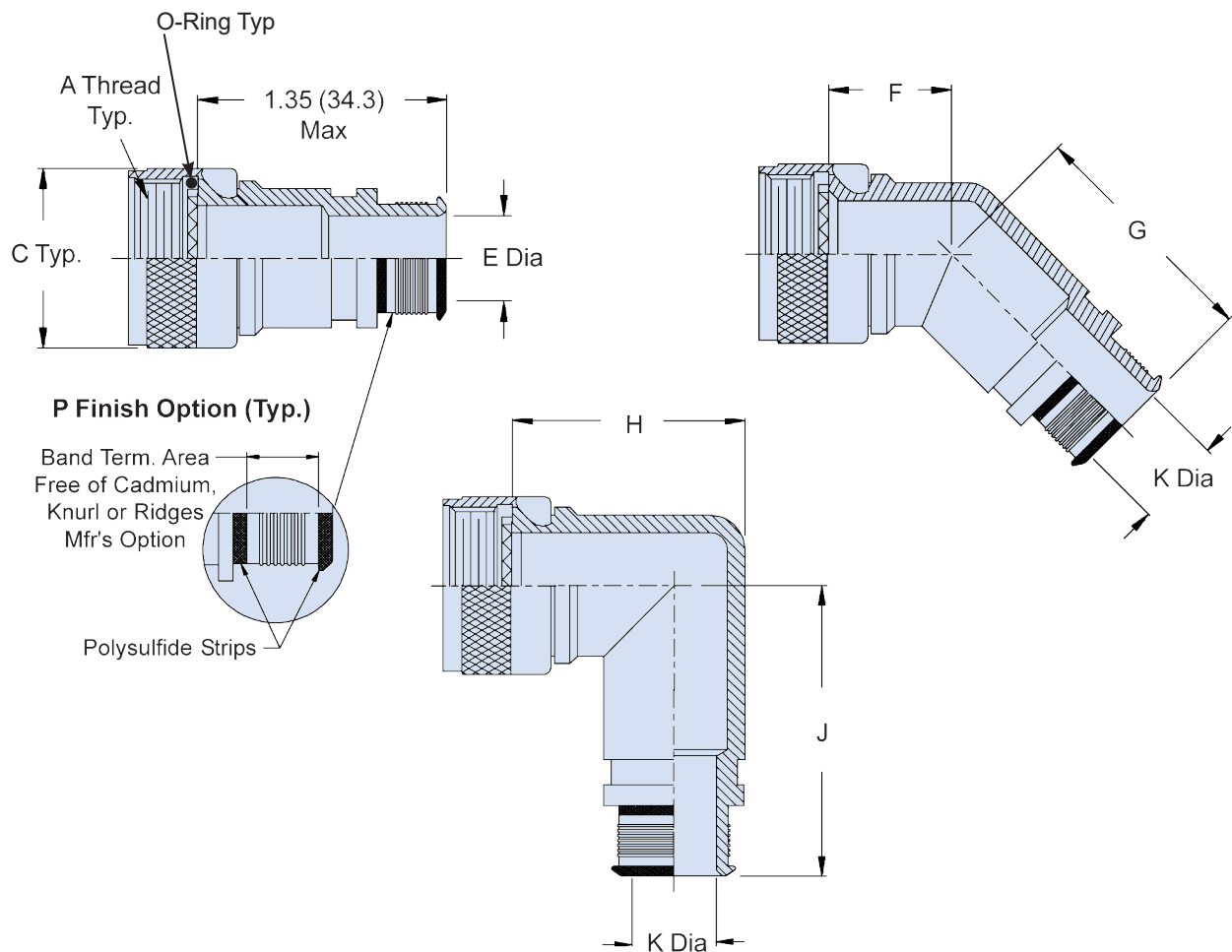

Dimensions in inches (millimeters) and are subject to change without notice.

Rev. 11.09.20

© 2013 Glenair, Inc.

Mil-Spec Backshells

U.S. CAGE Code 06324

Printed in U.S.A.



## AS85049/85, AS85049/86 and AS85049/87 Straight, 45° and 90° Banding Backshells with Self-Locking Coupling

**TABLE I: Shell Size, Cable Entry and Backshell Dimensions**

Shell Size	A Thread Class 2B	C Dia Max	F Max	G Max	H Max	J Max
08	.438 - 28 UNEF	.860 (21.8)	.870 (22.1)	1.160 (29.5)	1.375 (34.9)	1.375 (34.9)
10	.562 - 24 UNEF	.990 (25.1)	.900 (22.9)	1.190 (30.2)	1.437 (36.5)	1.437 (36.5)
12	.688 - 24 UNEF	1.160 (29.5)	.920 (23.4)	1.210 (30.7)	1.562 (39.7)	1.562 (39.7)
14	.813 - 20 UNEF	1.280 (32.5)	.950 (24.1)	1.240 (31.5)	1.687 (42.8)	1.687 (42.8)
16	.938 - 20 UNEF	1.410 (35.8)	.980 (24.9)	1.260 (32.0)	1.750 (44.5)	1.750 (44.5)
18	1.063 - 18 UNEF	1.520 (38.6)	.980 (24.9)	1.270 (32.3)	1.875 (47.6)	1.875 (47.6)
20	1.188 - 18 UNEF	1.640 (41.7)	1.010 (25.7)	1.300 (33.0)	1.938 (49.2)	1.938 (49.2)
22	1.313 - 18 UNEF	1.770 (45.0)	1.040 (26.4)	1.330 (33.8)	2.062 (52.4)	2.062 (52.4)
24	1.438 - 18 UNEF	1.890 (48.0)	1.070 (27.2)	1.350 (34.3)	2.125 (54.0)	2.125 (54.0)

**TABLE II: Shell Size and Cable Entry for Straight Configuration Only**

Shell Size	E Dia Cable Entry Size 01 ±.010 (0.30)	E Dia Cable Entry Size 02 ±.010 (0.30)
08	N/A	.250 (6.4)
10	N/A	.312 (7.9)
12	.312 (7.9)	.438 (11.1)
14	.438 (11.1)	.562 (14.3)
16	.500 (12.7)	.625 (15.9)
18	.625 (15.9)	.750 (19.1)
20	.625 (15.9)	.812 (20.6)
22	.688 (17.5)	.938 (23.8)
24	.750 (19.1)	1.000 (25.4)

**TABLE III: Shell Size and Cable Entry for 45° and 90° Configurations Only**

Shell Size	K Dia Cable Entry Size 02 ±.010 (0.30)	K Dia Cable Entry Size 03 ±.010 (0.30)
08	N/A	.250 (6.4)
10	N/A	.312 (7.9)
12	.312 (7.9)	.438 (11.1)
14	.438 (11.1)	.562 (14.3)
16	.500 (12.7)	.625 (15.9)
18	.625 (15.9)	.750 (19.1)
20	.625 (15.9)	.812 (20.6)
22	.688 (17.5)	.938 (23.8)
24	.750 (19.1)	1.000 (25.4)

### APPLICATION NOTES

1. Assembly identified with manufacturer's name and part number, space permitting.
2. For complete dimensions, see the applicable Military Specification.
3. Metric dimensions (mm) are in parentheses.
4. For use with AS85049/128 Bands.

Dimensions in inches (millimeters) and are subject to change without notice.