

600HH005
Connector Holding Tool
MIL-DTL-38999 Series IV
Plug and Receptacle

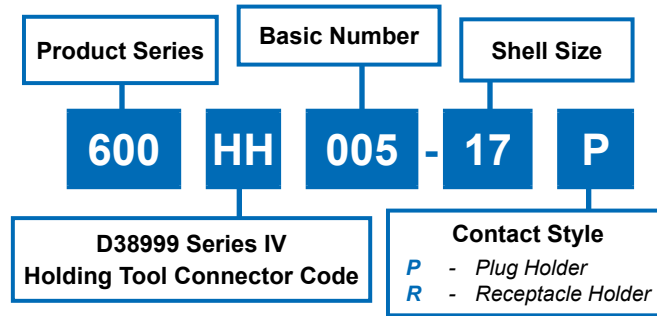

NO POLARIZATION REQUIRED

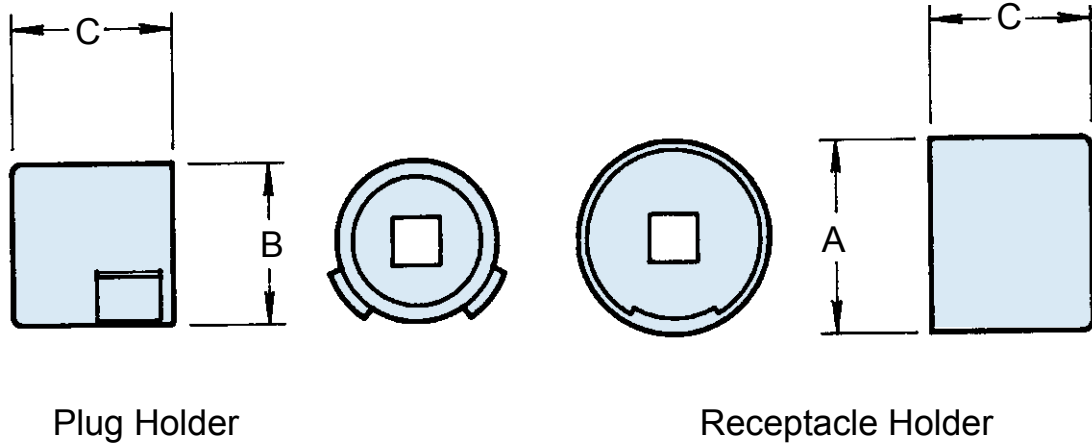

Shell Size		Max. Recommended Torque (Inch Pounds)	A Dia. Max.	B Dia. Max.	C Dim. Max.
Com'l	Mil. Ref.				
11	B	80	.83 (21.1)	.515 (13.1)	1.28 (32.5)
13	C	110	.95 (24.1)	.650 (16.5)	1.28 (32.5)
15	D	120	1.07 (27.2)	.775 (19.7)	1.28 (32.5)
17	E	120	1.20 (30.5)	.901 (22.9)	1.28 (32.5)
19	F	120	1.28 (32.5)	1.015 (25.8)	1.28 (32.5)
21	G	140	1.40 (35.6)	1.140 (29.0)	1.28 (32.5)
23	H	140	1.53 (38.9)	1.265 (32.1)	1.28 (32.5)
25	J	140	1.66 (42.2)	1.392 (35.4)	1.28 (32.5)

NOTES

1. Metric dimensions (mm) are indicated in parentheses.
2. Material: Case hardened carbon steel with electroless nickel finish.
3. Receptacle and plug holder drives: 1/4" - Shell sizes 11 and 13; 3/8" - Shell sizes 15 and up.

