



447-425
EMI/RFI Non-Environmental Band-in-a-Can Backshell
With Cable Clamp Strain-Relief
Rotatable Coupling - Standard Profile

Connector Designators:

MIL-DTL-38999 Series I, II (F)
MIL-DTL-38999 Series III and IV (H)

F-H
ROTATABLE
COUPLING

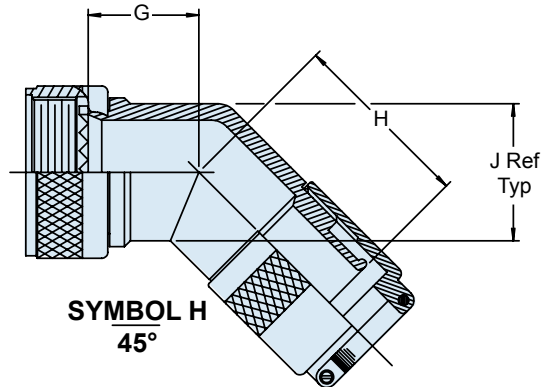
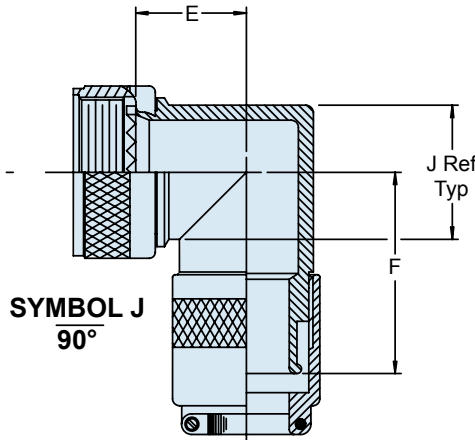
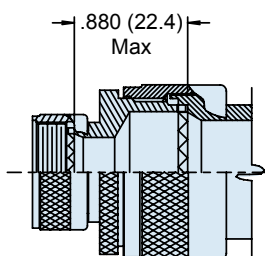
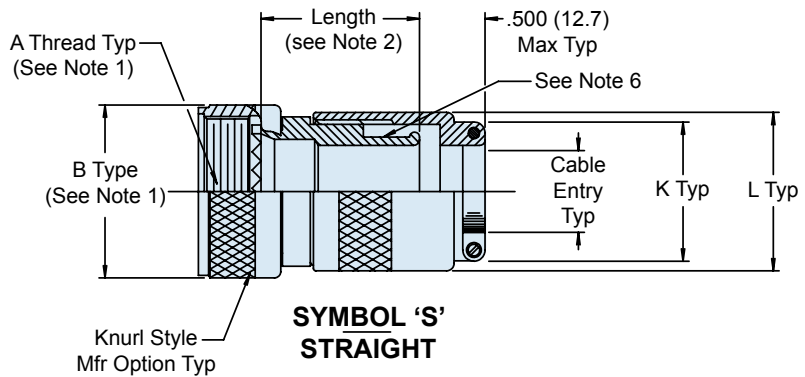
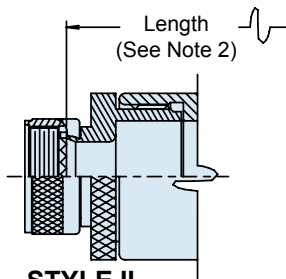
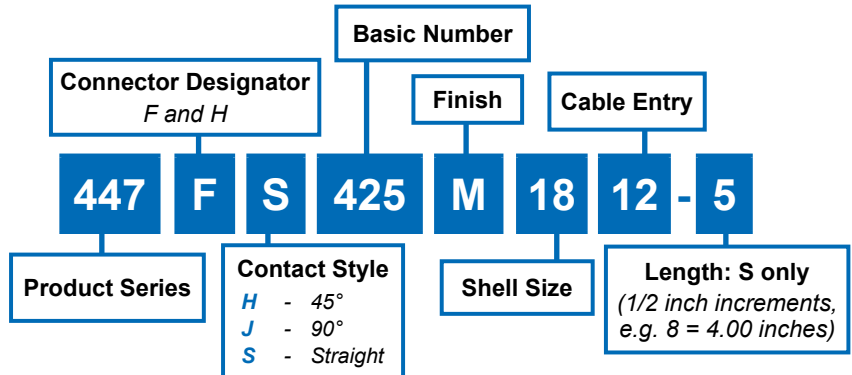

APPLICATION NOTES

- Standard minimum length for Style I is 1 inch (25.4), Style II is 1.5 inches (38.1). Consult factory about shorter lengths (Note: Applies to Symbol S Straight only).
- When cable diameter exceeds "Max Dash No" in Table I, Style II will be supplied.
- For effective grounding, connector with conductive finish should be used.
- Glenair Series 600 Backshell Assembly tools are recommended for assembly and installation.
- For shield termination see Glenair Drawings 600-050 and 600-052.
- Material/Finish:
Adapters, Elbows, Coupling Nuts, Ferrule, Clamp - Al Alloy/See Table I
Hardware - Cres/Passivate
- Metric dimensions (mm) are indicated in parentheses.

447-425
EMI/RFI Non-Environmental Band-in-a-Can Backshell
With Cable Clamp Strain-Relief
Rotatable Coupling - Standard Profile



Connector Accessories

TABLE III: BACKSHELL DIMENSIONS (Continued Below)

Shell Size									
A,F,L,S	H	E Max.	F Max.	G Max.	H Max.	M Max.	N Max.	P Max.	
08	09	.639 (16.23)	1.380 (35.05)	.750 (19.05)	1.500 (38.10)	.817 (20.75)	1.057 (26.85)	1.125 (28.58)	
10	11	.664 (16.87)	1.410 (35.81)	.810 (20.57)	1.550 (39.37)	.861 (21.87)	1.111 (28.22)	1.250 (31.75)	
12	13	.688 (17.48)	1.430 (36.32)	.870 (22.10)	1.610 (40.89)	.911 (23.14)	1.161 (29.49)	1.375 (34.93)	
14	15	.705 (17.91)	1.460 (37.08)	.920 (23.37)	1.680 (42.67)	.965 (24.51)	1.215 (30.86)	1.500 (38.10)	
16	17	.732 (18.59)	1.480 (37.59)	.980 (24.89)	1.740 (44.20)	1.264 (32.11)	1.625 (41.28)	1.875 (47.63)	
18	19	.748 (19.00)	1.490 (37.85)	1.020 (25.91)	1.760 (44.70)	1.064 (27.03)	1.314 (33.38)	1.750 (44.45)	
20	21	.773 (19.63)	1.510 (38.35)	1.080 (27.43)	1.820 (46.23)	1.118 (28.40)	1.368 (34.75)	1.875 (47.63)	
22	23	.800 (20.32)	1.550 (39.37)	1.140 (28.96)	1.900 (48.26)	1.172 (29.77)	1.422 (36.12)	2.000 (50.80)	
24	25	.823 (20.90)	1.580 (40.13)	1.200 (30.48)	1.970 (50.04)	1.221 (31.01)	1.471 (37.36)	2.125 (53.98)	
28		.930 (23.62)	1.610 (40.89)	1.380 (35.05)	2.000 (40.80)	1.271 (32.28)	1.522 (38.66)	2.250 (57.15)	
32		.980 (24.89)	1.610 (40.89)	1.500 (38.10)	2.000 (40.80)	1.375 (34.93)	1.626 (41.30)	2.500 (63.50)	
36		1.040 (26.42)	1.610 (40.89)	1.620 (41.15)	2.040 (51.82)	TBD	TBD	TBD	
40		1.100 (27.94)	1.610 (40.89)	1.740 (44.20)	2.150 (54.61)	TBD	TBD	TBD	
44		1.150 (29.21)	1.610 (40.89)	1.870 (47.50)	2.280 (57.91)	TBD	TBD	TBD	
48		1.200 (30.48)	1.640 (41.66)	1.990 (50.55)	2.400 (60.96)	TBD	TBD	TBD	
61		.880 (22.35)	1.580 (40.13)	1.260 (32.00)	1.970 (50.04)	1.221 (31.01)	1.417 (35.99)	2.125 (53.98)	

TABLE III: BACKSHELL DIMENSIONS (Continued From Above)

Shell Size											Function C Max. Wire Bundle
A,F,L,S	H	R Max.	S Max.	T Max.	U Max.	V Max.	W Max.	Y Max.	Z Ref.		
08	09	1.375 (34.93)	.520 (13.21)	1.840 (46.74)	.680 (17.27)	1.780 (45.21)	.681 (17.30)	2.120 (53.85)	.340 (8.64)	.250 (6.35)	
10	11	1.500 (38.10)	.520 (13.21)	1.900 (48.26)	.750 (19.05)	1.840 (46.74)	.731 (18.57)	2.280 (57.91)	.270 (6.86)	.375 (9.53)	
12	13	1.625 (41.28)	.560 (14.22)	1.970 (50.04)	.810 (20.57)	1.910 (48.51)	.731 (18.57)	2.280 (57.91)	.270 (6.86)	.375 (9.53)	
14	15	1.750 (44.45)	.620 (15.75)	2.000 (50.80)	.870 (22.10)	1.940 (49.28)	.831 (21.11)	2.350 (59.69)	.280 (7.11)	.500 (12.70)	
16	17	.680 (17.27)	2.100 (53.34)	.930 (23.62)	2.040 (51.82)	2.040 (51.82)	.981 (24.92)	2.400 (60.96)	.420 (10.67)	.625 (15.88)	
18	19	2.000 (40.80)	.750 (19.05)	2.160 (54.86)	1.000 (25.40)	2.100 (53.34)	1.181 (30.00)	2.430 (61.72)	.640 (16.26)	.625 (15.88)	
20	21	2.125 (53.98)	.820 (20.83)	2.220 (56.39)	1.060 (26.92)	2.160 (54.86)	1.181 (30.00)	2.430 (61.72)	.640 (16.26)	.625 (15.88)	
22	23	2.250 (57.15)	.880 (22.35)	2.280 (57.91)	1.120 (28.45)	2.220 (56.39)	1.181 (30.00)	2.580 (65.53)	.540 (13.72)	.750 (19.05)	
24	25	2.375 (60.33)	.940 (23.88)	2.340 (59.44)	1.180 (29.97)	2.280 (57.91)	1.181 (30.00)	2.580 (65.53)	.540 (13.72)	.750 (19.05)	
28		2.500 (63.50)	1.090 (27.69)	2.460 (62.48)	1.340 (34.04)	2.450 (62.23)	TBD	TBD	TBD	TBD	
32		2.750 (69.85)	TBD	TBD	TBD	TBD	TBD	TBD	TBD	TBD	
36		TBD	TBD	TBD	1.590 (40.39)	2.680 (68.07)	TBD	TBD	TBD	TBD	
40		TBD	TBD	TBD	1.720 (43.69)	2.890 (73.41)	TBD	TBD	TBD	TBD	
44		TBD	TBD	TBD	TBD	TBD	TBD	TBD	TBD	TBD	
48		TBD	TBD	TBD	TBD	TBD	TBD	TBD	TBD	TBD	
61		2.375 (60.33)	.940 (23.88)	TBD	1.180 (29.97)	2.290 (58.17)	1.181 (30.00)	2.580 (65.53)	.540 (13.72)	.750 (19.05)	

TABLE IV: CABLE ENTRY

Dash No.	K Max.	L Max.	Cable Entry	
			Min.	Max.
10	.220 (5.6)	.1000 (25.4)	.130 (3.3)	.250 (6.4)
12	.310 (7.9)	1.250 (31.8)	.250 (6.4)	.380 (9.7)
14	.440 (11.2)	1.340 (34.0)	.310 (7.9)	.440 (11.2)
16	.560 (14.2)	1.470 (37.3)	.375 (9.5)	.630 (16.0)
18	.630 (16.0)	1.560 (39.6)	.560 (14.2)	.960 (17.5)
20	.750 (19.1)	1.620 (41.1)	.630 (16.0)	.750 (19.1)
22	.880 (22.4)	1.750 (44.5)	.750 (19.1)	.880 (22.4)
24	1.000 (25.4)	1.870 (47.5)	.880 (22.4)	1.000 (25.4)
28	1.060 (26.9)	1.970 (50.0)	1.000 (25.4)	1.130 (28.7)
32	1.190 (30.2)	2.090 (53.1)	1.130 (28.7)	1.250 (31.8)

TABLE II: FINISHES

Symbol	Finish
B	Cadmium Plate, Olive Drab
C	Anodize, Black
GB	Black Anodize, Hard Coat
M	Electroless Nickel
N	Cad Plate, Olive Drab over Electroless Nickel
NF	Cadmium Plate, Olive Drab over Electroless Nickel
MT	Ni-PTFE 1000 Hour Grey™ Nickel Fluorocarbon Polymer
Z1	Stainless Steel Passivate
ZL	CRES, Electroless Nickel
ZN	Zinc-Nickel

