

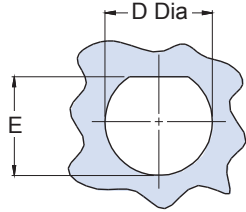

233-103-H7 Jam Nut Mount Hermetic Bulkhead Feed-Thru MIL-DTL-38999 Series III Type

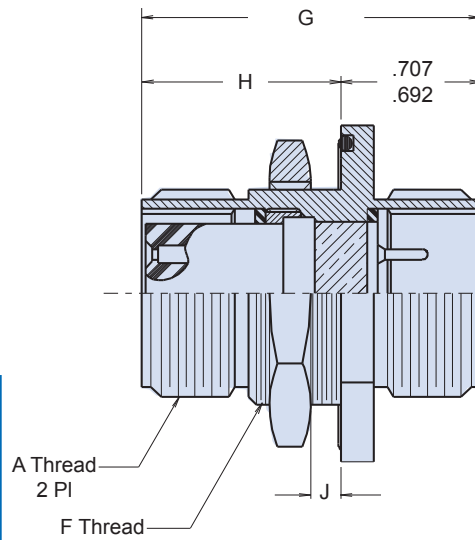
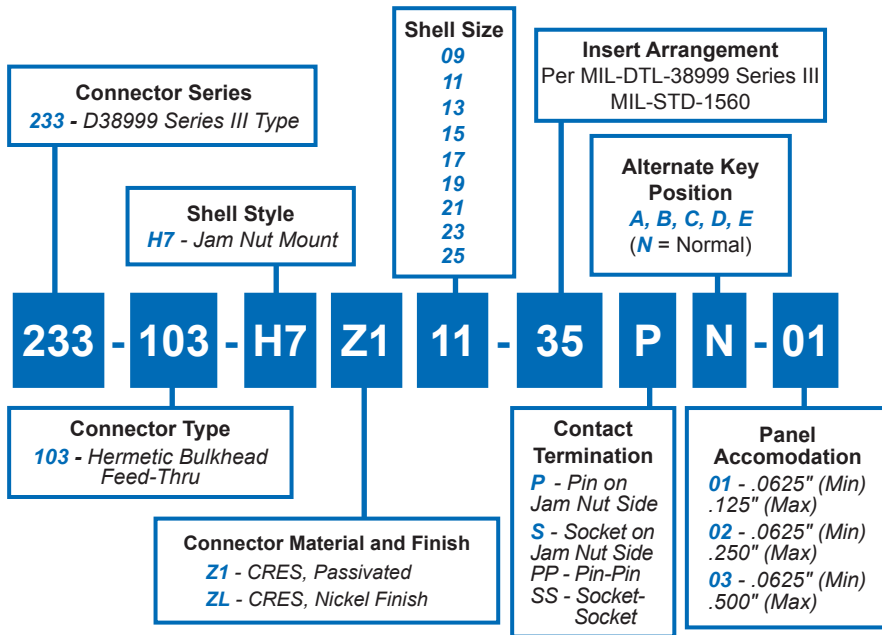

Recommended Panel Cut-Out

HERMETIC LEAK RATE MOD CODES	
Designator	Required Leak Rate
-585A	1 x 10 ⁻¹⁰ cc Helium per second
-585B	1 x 10 ⁻⁹ cc Helium per second
-585C	1 x 10 ⁻⁸ cc Helium per second

TABLE I: CONNECTOR DIMENSIONS

	G Dim, OAL Max	H Dim, Max	J Dim, Panel
-01	1.650 (41.91)	.889 (22.58)	.125 (3.18) .062 (1.57)
-02	1.780 (45.21)	1.090 (27.69)	.250 (6.35) .062 (1.57)
-03	.8750 (51.56)	1.340 (34.04)	.500 (12.7) .062 (1.57)

TABLE II: CONNECTOR DIMENSIONS						
SHELL SIZE	A THREAD 0.1 P-0.3L-TS-2	B DIA	C	D DIA	E DIM	F THREAD METRIC
09	.6250	1.189 (30.20)	1.063 (27.00)	.703 (17.86) .693 (17.60)	.657 (16.69) .655 (16.64)	M17 x 1.0-6g
11	.7500	1.375 (34.93)	1.252 (31.80)	.835 (21.21) .825 (20.96)	.771 (19.58) .769 (19.53)	M20 x 1.0-6g
13	.8750	1.500 (38.10)	1.374 (34.90)	1.020 (25.91) 1.010 (25.65)	.955 (24.26) .953 (24.21)	M25 x 1.0-6g
15	1.0000	1.626 (41.30)	1.500 (38.10)	1.145 (29.03) 1.135 (28.83)	1.085 (27.56) 1.083 (27.51)	M28 x 1.0-6g
17	1.1875	1.752 (44.50)	1.626 (41.30)	1.270 (32.26) 1.260 (32.00)	1.210 (30.73) 1.208 (30.68)	M32 x 1.0-6g
19	1.2500	1.937 (49.20)	1.811 (46.00)	1.395 (35.43) 1.385 (35.18)	1.335 (33.91) 1.333 (33.86)	M35 x 1.0-6g
21	1.3750	2.063 (52.40)	1.937 (49.20)	1.520 (38.61) 1.510 (38.35)	1.460 (37.08) 1.558 (39.57)	M38 x 1.0-6g
23	1.5000	2.189 (55.60)	2.063 (52.40)	1.645 (41.78) 1.635 (41.53)	1.585 (40.26) 1.583 (40.21)	M41 x 1.0-6g
25	1.6250	2.311 (58.70)	2.189 (55.60)	1.770 (44.96) 1.760 (44.70)	1.710 (43.34) 1.708 (43.38)	M44 x 1.0-6g

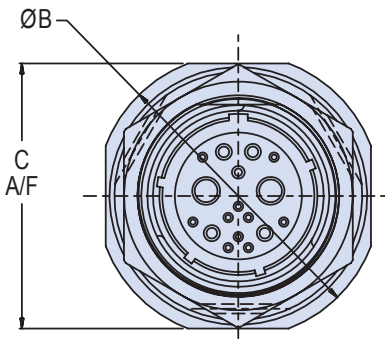

Insert Arrangement per MIL-DTL-38999 Series III MIL-STD-1560

APPLICATION NOTES

- Power to a given contact on one end will result in power to contact directly opposite, regardless of identification letter.
- Hermeticity = less than 1 x 10⁻⁷ cc/sec at one atmosphere. Not for use in liquid atmosphere.
- Material/finish:
Shell, nut – CRES/passivated, carbon steel/fused tin or CRES/nickel per QQ-N-290.
- Contacts – Gold Plated. Pin: alloy 52; Skt.: copper alloy
Insulator – fused vitreous glass/N.A.
Seals – fluorosilicone rubber/N.A.