

**233-105-00**  
**MIL-DTL-38999 Series III Type**  
**Wall Mount Environmental Receptacle Connector**

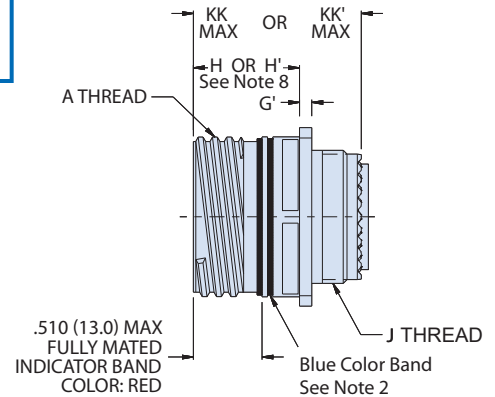

**D0 - ROUND HOLES**

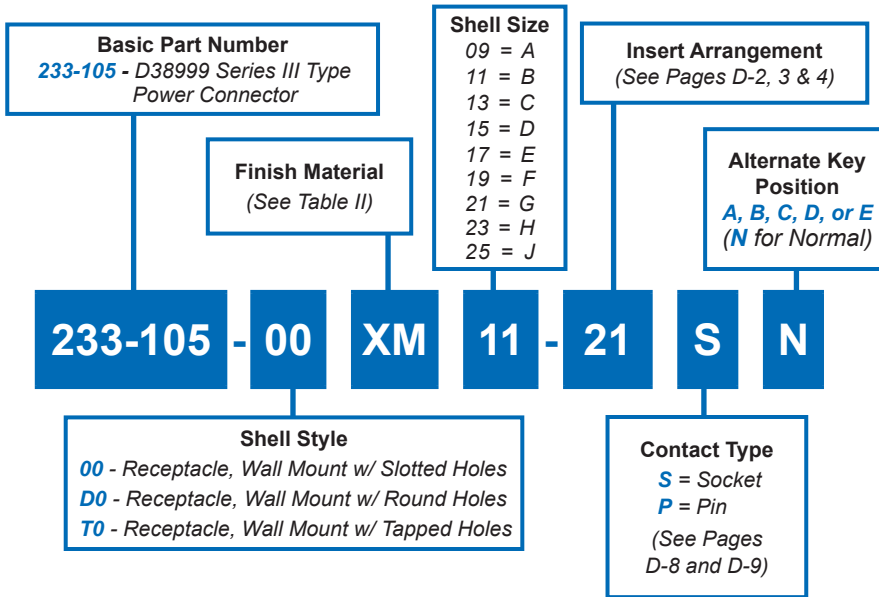
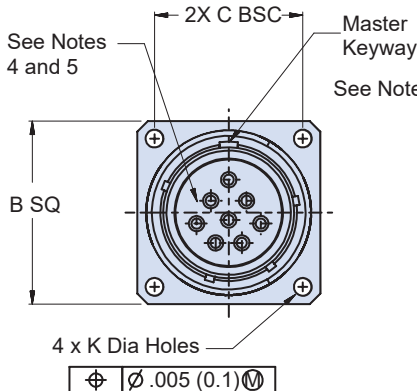

**00 - SLOTTED HOLES**

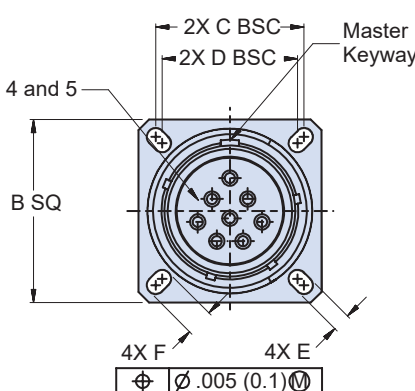

**T0 - TAPPED HOLES**

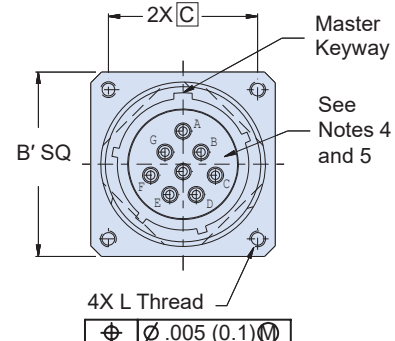

Consult factory for available insert arrangements.

**APPLICATION NOTES**

- Material/ Finishes:  
Shells, Jam Nut - See Table II (Composite Jam Nut & Composite Coupling Nut No Plating Required).  
Insulators- High Grade Rigid Dielectric/ N.A.  
Seals- Fluorosilicone/ N.A.
- Blue Color Band indicates rear release retention system.
- Assembly to be identified with Glenair's name, part number and date code space permitting.
- Insert arrangement in accordance with MIL-STD-1560.
- Insert arrangement shown is for reference only.
- Metric dimensions (mm) are in parentheses.
- Composite connectors use dimensions G', H', and KK'.
- For shell style T0 only dimensions H and G' apply.

**TABLE II: FINISH**

SYM	MATERIAL	FINISH	MIL SYM
ME	Aluminum	Electroless Nickel	F
NF		Cadmium O.D. Over Electroless Nickel	W
ZN		Zinc Ni, Olive Drab	Z
ZE		Zinc Ni, No Chromate	
ZR		Zinc Ni, Black (Tri-Valent CR)	
AL		Pure-Dense Electro-Deposited Aluminum	P
MT		Ni-PTFE 1000 Hour Grey™	T
XM	Composite	Electroless Nickel	M
XMT		Ni-PTFE 1000 Hour Grey™	
XO		No Finish	
XW		Cadmium O.D. over Electroless Nickel	J
Z1	Stainless Steel	Passivate	
ZC		Zinc Colbalt	
ZL		Electro-Deposited Nickel	
ZW		Cadmium O.D. over Nickel	
AB	Marine Bronze	None (Clean Only)	

\*Consult Factory for Additional Plating Options

**TABLE III: SHELL SIZE**

Shell Size Code	Shell Size	A Thread	B SQ	B' SQ	C BSC	D BSC	E	F	G	H	J Thread	K Holes Dia
A	9	.6250-.1P-.3L-TS-2A	.949 (24.1) .925 (23.5)	1.039 (26.39) .999 (25.37)	.719 (18.3)	.594 (15.1)	.136 (3.5) .120 (0.1)	.224 (5.7) .208 (5.3)	.144 (3.7) .083 (2.1)	.820 (20.8) .768 (19.5)	M12 x 1.0-6g 0.100R	.136 (3.5) .120 (3.0)
B	11	.7500-.1P-.3L-TS-2A	1.043 (26.5) 1.019 (25.9)	1.132 (28.75) 1.092 (27.74)	.812 (20.6)	.719 (18.3)	.136 (3.5) .120 (0.1)	.202 (5.1) .188 (4.7)	.144 (3.7) .083 (2.1)	.820 (20.8) .768 (19.5)	M15 x 1.0-6g 0.100R	.136 (3.5) .120 (3.0)
C	13	.8750-.1P-.3L-TS-2A	1.138 (28.9) 1.114 (28.3)	1.226 (31.14) 1.186 (30.12)	.906 (23.0)	.812 (20.6)	.136 (3.5) .120 (0.1)	.202 (5.1) .188 (4.7)	.144 (3.7) .083 (2.1)	.820 (20.8) .768 (19.5)	M18 x 1.0-6g 0.100R	.136 (3.5) .120 (3.0)
D	15	1.0000-.1P-.3L-TS-2A	1.232 (31.3) 1.208 (30.7)	1.289 (32.74) 1.249 (31.72)	.969 (24.6)	.906 (23.0)	.136 (3.5) .120 (0.1)	.202 (5.1) .208 (5.3)	.144 (3.7) .083 (2.1)	.820 (20.8) .768 (19.5)	M22 x 1.0-6g 0.100R	.136 (3.5) .120 (3.0)
E	17	1.1875-.1P-.3L-TS-2A	1.323 (33.6) 1.299 (33.0)	1.382 (35.10) 1.342 (34.09)	1.062 (27.0)	.969 (24.6)	.136 (3.5) .120 (0.1)	.202 (5.1) .188 (4.7)	.144 (3.7) .083 (2.1)	.820 (20.8) .768 (19.5)	M25 x 1.0-6g 0.100R	.136 (3.5) .120 (3.0)
F	19	1.2500-.1P-.3L-TS-2A	1.449 (36.8) 1.425 (36.2)	1.476 (37.49) 1.436 (36.47)	1.156 (29.4)	1.062 (27.0)	.136 (3.5) .120 (0.1)	.202 (5.1) .188 (4.7)	.144 (3.7) .083 (2.1)	.820 (20.8) .768 (19.5)	M28 x 1.0-6g 0.100R	.136 (3.5) .120 (3.0)
G	21	1.3750-.1P-.3L-TS-2A	1.575 (40.0) 1.551 (39.4)	1.582 (40.18) 1.542 (39.17)	1.250 (31.8)	1.156 (29.4)	.136 (3.5) .120 (0.1)	.202 (5.1) .188 (4.7)	.171 (65.2) .083 (39.8)	.790 (20.1) .736 (18.7)	M31 x 1.0-6g 0.100R	.136 (3.5) .120 (3.0)
H	23	1.5000-.1P-.3L-TS-2A	1.701 (43.2) 1.677 (42.6)	1.739 (44.17) 1.699 (43.15)	1.375 (34.9)	1.250 (31.8)	.162 (4.1) .146 (3.7)	.250 (6.4) .234 (5.9)	.171 (65.2) .083 (39.8)	.790 (20.1) .736 (18.7)	M34 x 1.0-6g 0.100R	.162 (4.1) .146 (3.7)
J	25	1.6250-.1P-.3L-TS-2A	1.823 (46.3) 1.799 (45.7)	1.884 (47.85) 1.824 (46.33)	1.500 (38.1)	1.375 (34.9)	.162 (4.1) .146 (3.7)	.250 (6.4) .234 (5.9)	.171 (65.2) .083 (39.8)	.790 (20.1) .736 (18.7)	M37 x 1.0-6g 0.100R	.162 (4.1) .146 (3.7)

**233-105-00**  
**MIL-DTL-38999 Series III Type**  
**Wall Mount Environmental Receptacle Connector**

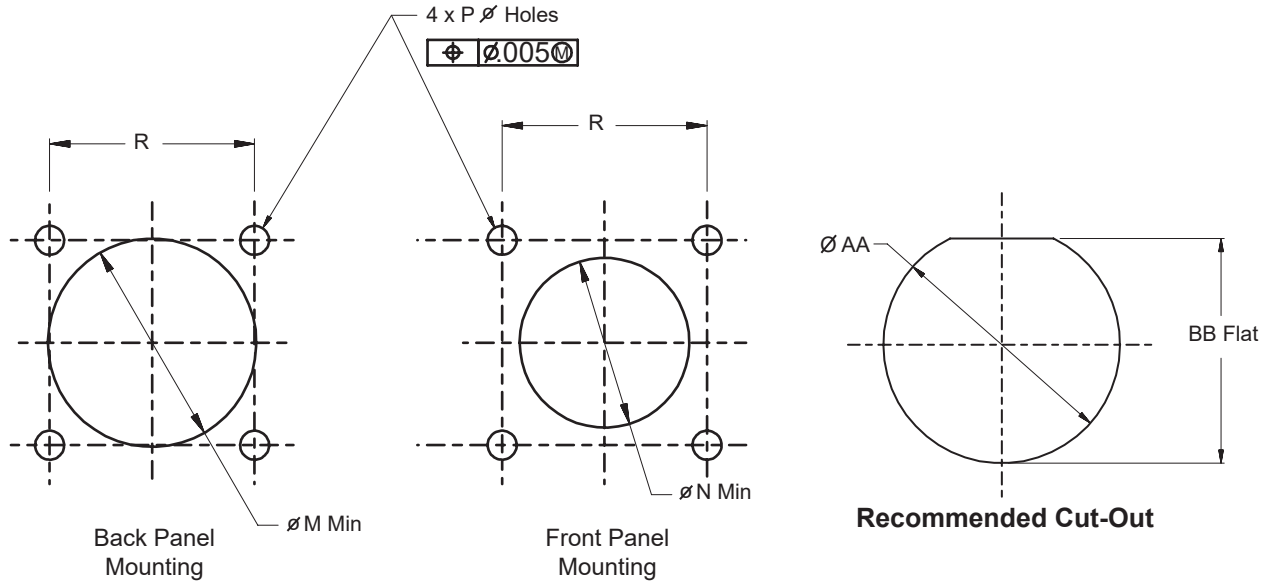

**Recommended Mounting Holes  
for Wall Mount Receptacle**

TABLE IV: SHELL SIZE							
Shell Size Code	Shell Size	AA Dia	BB Flat	M Ø Min	N Ø Min	P Ø Holes	R BSC
A	9	.703 (17.9)	.657 (16.7)	.656 (16.7)	.516 (13.1)	.133 (3.4)	.719 (18.3)
		.693 (17.6)	.655 (16.6)			.123 (3.1)	
B	11	.835 (21.2)	.771 (19.6)	.796 (20.2)	.625 (15.9)	.133 (3.4)	.812 (20.6)
		.825 (21.0)	.769 (19.5)			.123 (3.1)	
C	13	1.020 (25.9)	.955 (24.3)	.922 (23.4)	750 (19.1)	.133 (3.4)	.906 (23.0)
		1.010 (25.7)	.943 (24.0)			.123 (3.1)	
D	15	1.145 (29.1)	1.085 (27.6)	1.047 (26.6)	.906 (23.0)	.133 (3.4)	.969 (24.6)
		1.135 (28.8)	1.083 (27.5)			.123 (3.1)	
E	17	1.270 (32.3)	1.210 (30.7)	1.219 (31.0)	1.016 (25.8)	.133 (3.4)	1.062 (27.0)
		1.260 (32.0)	1.208 (30.7)			.123 (3.1)	
F	19	1.395 (35.4)	1.335 (33.9)	1.297 (32.9)	1.141 (29.0)	.133 (3.4)	1.156 (29.4)
		1.385 (35.2)	1.333 (33.9)			.123 (3.1)	
G	21	1.520 (38.6)	1.460 (37.1)	1.422 (36.1)	1.266 (32.2)	.133 (3.4)	1.250 (31.8)
		1.510 (38.4)	1.458 (37.0)			.123 (3.1)	
H	23	1.645 (41.8)	1.585 (40.3)	1.547 (39.3)	1.375 (34.9)	.159 (4.0)	1.375 (34.9)
		1.635 (41.5)	1.583 (40.2)			.149 (3.8)	
J	25	1.770 (45.0)	1.710 (43.4)	1.672 (42.5)	1.484 (37.7)	.155 (3.9)	1.500 (38.1)
		1.760 (44.7)	1.708 (43.4)			.145 (3.7)	

Metric dimensions (mm) are indicated in parentheses