

QPL QUALIFIED

MIL-DTL-38999 Series IV, Breech Coupling

38999/48 weld mount receptacle



SERIES IV HERMETIC

QPL Part Number Development						
Sample Part Number	D38999/48 Y B 35 P N					
D38999	38999/48 = Weld mount receptacle					
Class	N = Hermetic, CRES, nickel finish, conductive, -65°C to 200°C Y = Hermetic, CRES, passivate finish, conductive, -65°C to 200°C H = Hermetic, CRES, passivate finish, conductive, -65°C to 200°C (space grade)					
Shell Size	B, C, D, E, F, G, H, J					
Insert Arrangement	Per MIL-STD-1560; See reference information section for details					
Contact Style	P = Pin, solder cup S = Socket, solder cup		X = Pin, eyelet Z = Socket, eyelet		C = Pin, PCB flex feedthrough D = Socket, PCB flex feedthrough	
Polarization	N (Normal), A, B, C, D, K, L, M, R; see polarization positions table					



Polarization									
	N	A	B	C	D	K	L	M	R
XX	110°	100°	90°	80°	70°	120°	120°	120°	120°
YY	250°	260°	270°	280°	290°	255°	265°	275°	285°

Wire Accommodation	
Contact Size	Wire Gauge
22D	#22 - #28
20	#20 - #24
16	#16 - #20
12	#12 - #14

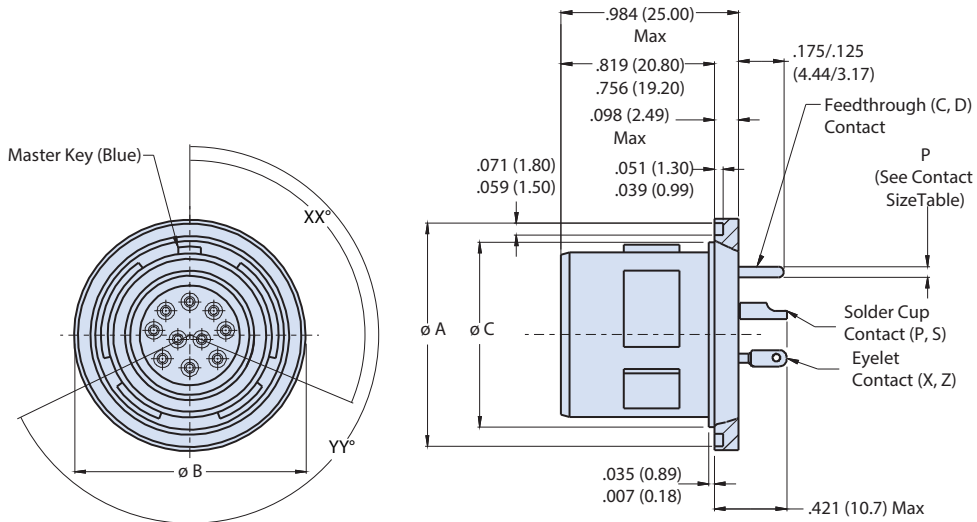

Consult Factory for Recommended Panel Cutout Dimensions

COTS EQUIVALENT
MIL-DTL-38999 Series IV, Breech Coupling
234-100-H8 weld mount receptacle



SERIES IV HERMETIC

DLA Equivalent Part Number Development						
Sample Part Number	234-100-H8		Z1	11	-35	P N
Series / Basic Part No.	234-100-H8 = Hermetic, weld mount receptacle					
Material/Finish*	ZL = CRES, nickel finish, conductive, -65°C to 200°C Z1 = CRES, passivate finish, conductive, -65°C to 200°C Z1S = Hermetic, CRES, passivate finish, conductive, -65°C to 200°C (space grade)					
Shell Size	11, 13, 15, 17, 19, 21, 23, 25					
Insert Arrangement	Per MIL-STD-1560; See reference information section for details					
Contact Style	P = Pin, solder cup S = Socket, solder cup		X = Pin, eyelet Z = Socket, eyelet		C = Pin, feedthrough D = Socket, feedthrough	
Polarization	N (Normal), A, B, C, D, K, L, M, R see polarization position table					

Contact Size	
FEEDTHROUGH CONTACT STYLE C AND D 	
SIZE 12 AND SIZE 16 .050 ± .015 (1.27 ± 0.38)	
SIZE 22D AND SIZE 20 	
Contact Size	ø P
22D	.011 (0.28) .015 (0.38)
20	.024 (0.61) .028 (0.71)
16	.0635 (1.61) .0615 (1.56)
12	.095 (2.41) .093 (2.36)

Dimensions				
SHELL SIZE CODE	SHELL SIZE	ø A	ø B	ø C
B	11	1.035 (26.3)	1.106 (28.1)	.793 (20.1)
		1.024 (26.0)	1.094 (27.8)	.778 (19.8)
C	13	1.161 (29.5)	1.232 (31.3)	.919 (23.3)
		1.150 (29.2)	1.220 (31.0)	.904 (23.0)
D	15	1.287 (32.7)	1.358 (34.5)	1.044 (26.5)
		1.276 (32.4)	1.346 (34.2)	1.029 (26.1)
E	17	1.374 (34.9)	1.445 (36.7)	1.170 (29.7)
		1.362 (34.6)	1.433 (36.4)	1.155 (29.3)
F	19	1.520 (38.6)	1.591 (40.4)	1.294 (32.9)
		1.508 (38.3)	1.579 (40.1)	1.279 (32.5)
G	21	1.661 (42.2)	1.732 (44.0)	1.419 (36.0)
		1.650 (41.9)	1.720 (43.7)	1.404 (35.7)
H	23	1.827 (46.4)	1.898 (48.2)	1.544 (39.2)
		1.815 (46.1)	1.886 (47.4)	1.529 (38.8)
J	25	1.913 (48.6)	1.984 (50.4)	1.669 (42.4)
		1.902 (48.3)	1.972 (50.1)	1.654 (42.0)