

# Series 806 Mil-Aero Connectors

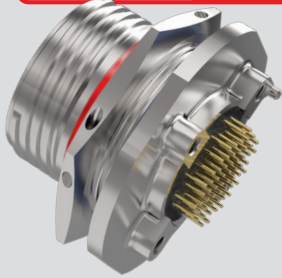

## 806-028 Lightweight Aluminum Hermetic Receptacles, PC Tail

**CODE RED**



### Features

- Triple-start stub ACME mating thread
- High density #20HD and #22HD arrangements for reduced size and weight plus size #16, #12, #8 standard and hybrid layouts
- Aerospace-grade material options, construction
- Integral PC board standoffs
- Threaded holes for secure attachment to rigid or flex circuits
- Alignment post

### Specifications

- Operating temperature: -65°C to +200°C
- Leak Rate: 1E-7 cm<sup>3</sup>/s at 1 ATM pressure differential
- Dielectric withstanding voltage  
#22HD layouts: 1300 VAC  
#20HD layouts: 1800 VAC  
#16 layouts: contact factory  
#12 layouts: contact factory  
#8 layouts: contact factory
- Mating durability: 500 cycles
- Mechanical shock: EIA-364-27, 300g.
- Vibration (sine): MIL-DTL-38999M, 60g.
- Vibration (random): EIA-364-28 Condition VI, Letter J, 43.92 Grms, +200°C
- High Impact shock: MIL-S-901 Grade A
- Salt spray (dynamic): EIA-364-26, 96 hours
- Altitude immersion: EIA-364-03 75,000 feet altitude
- Indirect Lightning Strike: EIA-364-75 Type B Level 2 10kA Peak

### Connector Construction

- Shell and jam-nut: see Table II
- Contacts: copper alloy, gold plating
- Sealing compound: proprietary Glenair formulation
- Dielectric inserts: high grade rigid dielectric
- Interfacial seal, peripheral seal, O-ring: fluorosilicone

*Lightweight aluminum Hermetic. Higher current rating.* 806-028 aluminum hermetic receptacles are lighter than stainless steel glass-to-metal hermetic connectors. A signature sealing process delivers reliable hermetic performance at extreme temperatures. Copper alloy contacts have lower resistance and higher current rating than iron alloy contacts used in standard hermetics. Hermeticity is 1E<sup>-7</sup> cm<sup>3</sup>/sec at 1 ATM pressure differential. Integral standoffs and threaded mounting holes offer secure attachment to rigid or flex circuits. Parylene compatible, and ideal for pressure bulkhead aerospace applications subject to severe vibration, moisture, and shock.

How To Order						
SAMPLE PART NUMBER	806-028	-ME	8-7	P	1	A
<b>Product</b>	806-028 = Jam-nut Receptacle with PC Tails					
<b>Shell Material and Finish</b>	See Table II					
<b>Arrangement Number (Shell Size - Insert Arr.)</b>	See Table I					
<b>Contact Type</b>	P = Pin S = Socket					
<b>PC Tail Length</b>	1 = .125" (3.18 mm.) 2 = .250" (6.35 mm.)					
<b>Polarization</b>	A B C D E F					

Please visit the hermetic catalog for a complete offering of our connectors.

Table I: Shell Size - Insert Arrangement																	
Contact Layout	Number of Contacts					Contact Layout	Number of Contacts					Contact Layout	Number of Contacts				
	22HD	20HD	16	12	8		22HD	20HD	16	12	8		22HD	20HD	16	12	8
7-3	3					22-69	69				16-2					2	
8-4	4					24-92	92				18-3					3	
8-7	7					8-1		1			20-4					4	
9-11	11					10-2		2			22-5					5	
10-15	15					11-4		4			24-8					8	
11-19	19					12-5		5			10-8A	6	2				
12-26	26					14-7		7			11-13	11	2				
14-39	39					16-12		12			12-27	26	1				
16-60	60					18-15		15			14-21	17	4				
18-85	85					20-22		22			16-41	37	4				
20-110	110					22-24		24			18-59	55	4				
22-140	140					24-35		35			11-14	13		1			
24-186	186					9-1			1		12-14	12		2			
8-3		3				12-2			2		14-22	20		2			
9-5		5				14-3			3		12-14	12		2			
10-8		8				16-4			4		16-42	40		2			
11-10		10				16-7			7		18-62	60		2			
12-15		15				18-8			8		14-20A	19			1		
14-20		20				20-11			11		16-22	20			2		
16-31		31				22-13			13		18-21	18			3		
18-41		41				24-19			19		20-28	24			4		
20-55		55				10-1				1	22-44	40			4		
											24-97	93				4	

# Series 806 Mil-Aero Connectors



## 806-028 Lightweight Aluminum Hermetic Receptacles, PC Tail

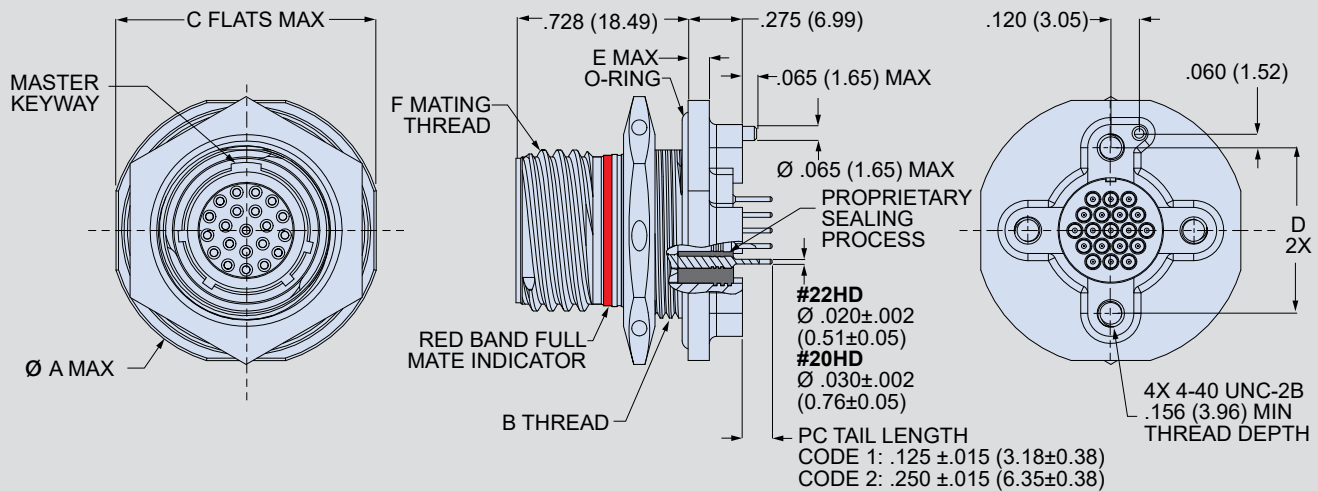

806-028 Receptacle Dimensions

Shell Size	$\varnothing A$ Max	B Thread	C Max	D	E Max	F Mating Thread
7	.848 (21.54)	M8x1.0-6g-0.100R	.908 (23.06)	.489 (12.42)	.100 (2.54)	.4375-.067P-.2L-TS-2A
8	.980 (24.89)	M15x1.0-6g-0.100R	.920 (23.37)	.534 (13.56)	.100 (2.54)	.5000-.067P-.2L-TS-2A
9	1.040 (26.42)	M16x1.0-6g-0.100R	.980 (24.89)	.579 (14.71)	.100 (2.54)	.5625-.067P-.2L-TS-2A
10	1.110 (28.19)	M18x1.0-6g-0.100R	1.050 (26.67)	.679 (17.25)	.100 (2.54)	.6250-.067P-.2L-TS-2A
11	1.160 (29.46)	M19x1.0-6g-0.100R	1.110 (28.19)	.734 (18.64)	.100 (2.54)	.6875-.067P-.2L-TS-2A
12	1.230 (31.24)	M21x1.0-6g-0.100R	1.170 (29.72)	.804 (20.42)	.100 (2.54)	.7500-.067P-.2L-TS-2A
14	1.360 (34.54)	M24x1.0-6g-0.100R	1.320 (33.53)	.891 (22.63)	.100 (2.54)	.8750-.067P-.2L-TS-2A
16	1.515 (38.48)	M27x1.0-6g-0.100R	1.444 (36.68)	1.049 (26.64)	.100 (2.54)	1.0000-.067P-.2L-TS-2A
18	1.610 (40.89)	M30x1.0-6g-0.100R	1.570 (39.88)	1.148 (29.16)	.100 (2.54)	1.1250-.067P-.2L-TS-2A
20	1.850 (46.99)	M34x1.0-6g-0.100R	1.760 (44.70)	1.252 (31.80)	.128 (3.25)	1.2500-.067P-.2L-TS-2A
22	2.010 (51.05)	M37x1.0-6g-0.100R	1.913 (48.59)	1.369 (34.77)	.128 (3.25)	1.3750-.067P-.2L-TS-2A
24	2.195 (55.75)	M41x1.0-6g-0.100R	2.070 (52.58)	1.509 (38.33)	.128 (3.25)	1.5000-.067P-.2L-TS-2A

806-028 Jam-nut D-Hole Dims.

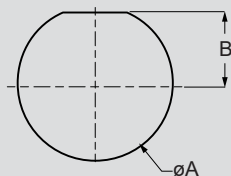

Shell Size	$\varnothing A$ +0.005/-0.00 (+0.13/-0.00)	B +0.005/-0.00 (+0.13/-0.00)
7	.552 (14.02)	.224 (5.69)
8	.601 (15.27)	.256 (6.50)
9	.640 (16.26)	.287 (7.29)
10	.719 (18.26)	.318 (8.08)
11	.759 (19.28)	.350 (8.89)
12	.837 (21.26)	.381 (9.68)
14	.955 (24.26)	.443 (11.25)
16	1.073 (27.25)	.505 (12.83)
18	1.192 (30.28)	.568 (14.43)
20	1.349 (34.26)	.630 (16.00)
22	1.467 (37.26)	.693 (17.60)
24	1.624 (41.25)	.755 (19.18)

Table II: Material and Finish

Sym	Material	Finish	Temp. Range
AB	Marine Bronze	None (Clean Only)	-65° to +200°C
M	Aluminum Alloy	Electroless Nickel,	
MA		Electroless Nickel, Matte Finish	
ME		Electroless Nickel	
NF		Cad/O.D. over electroless nickel	-65° to +175°C
ZN	Zinc Ni, Olive Drab		
ZR	Zinc Ni, Black (Tri-Valent CR)		