

# SERIES 80 MIGHTY MOUSE CONNECTORS Accessories, Backshells, and Tools

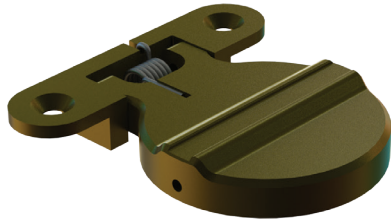

## Series 804 Mighty Mouse Spring Loaded, ProSeal™ Low Profile Spring Action Cover for Jam Nut Connectors



How to Order 667-392			
Sample Part Number	667-392	NF	09
Series	ProSeal protective cover for Series 804 Mighty Mouse Wall Mount connectors		
Material / Finish	See Table II		
Shell Size	See Table I		

- Pressure seal, dust and immersion resistant
- Self-aligning
- Positive spring-action in closed position. Opens to 90°, non-locking.

Table I: Dimensions												
Shell Size	A Dia		B Dim		C ±.005		D Dim		E ±.005		F Dim	
	in	mm	in	mm	in	mm	in	mm	in	mm	in	mm
06	.75	19.05	1.51	38.35	1.055	26.80	.84	21.34	.615	15.62	1.17	29.72
07	.87	22.10	1.58	40.13	1.125	28.58	.87	22.10	.640	16.26	1.25	31.75
08	.87	22.10	1.58	40.13	1.125	28.58	.90	22.86	.673	17.09	1.32	33.53
09	.94	23.88	1.58	40.13	1.125	28.58	.90	22.86	.673	17.09	1.32	33.53
10	1.00	25.40	1.58	40.13	1.125	28.58	.94	23.88	.712	18.08	1.39	35.31
12	1.12	28.45	1.58	40.13	1.125	28.58	1.03	26.16	.800	20.32	1.53	38.86
14	1.25	31.75	1.70	43.18	1.245	31.62	1.08	27.43	.855	21.72	1.69	42.93
15	1.31	33.27	1.70	43.18	1.245	31.62	1.10	27.94	.875	22.23	1.74	44.20

Consult factory for additional shell sizes

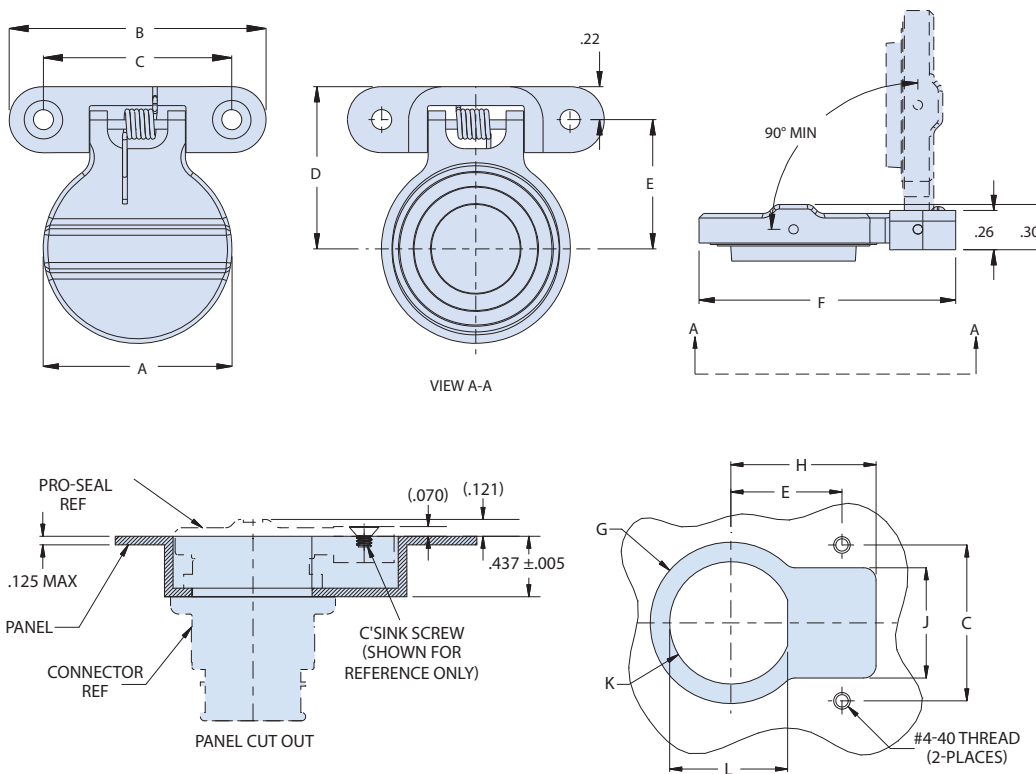

### MATERIAL / FINISH

- Cover, Lever Arm, Bracket - Aluminum Alloy/see Table II
- Shaft / Spring - CRES / Passivate
- Sleeve - Delrin
- Gasket - Silicone

Table II: Material and Finish		
Sym	Material	Finish
M	Aluminum Alloy	Electroless Nickel
NF		Cad Plate / Olive Drab over Electroless Nickel
C		Anodize / Black
ZN		Zinc-Nickel / O.D. over Electroless Nickel
ZR		Zinc-Nickel / Black over Electroless Nickel