



SERIES 80 MIGHTY MOUSE CONNECTORS Accessories, Backshells, and Tools



Series 800, 801, 803, 804 and 805 Direct Coupling, Shield Termination Adapter



440MS134

Band-Master™ ATS
Microband
601-061



Add a boot or overmold for environmental protection (shown without boot)

These adapters are for use with **Band-Master™ ATS Micro Band** shield termination straps. Choose the smallest cable entry for your wire bundle.

Band-Master™ ATS
Micro Band Tool
601-101



NOTES

- Materials
 - Adapter: Aluminum Alloy or SST
 - Band: SST
 - O-Ring: Silicone Elastomer

How To Order					
Sample Part Number	440MS134	NF	07	04	B
Series	440MS134 = Straight Entry				
Shell Material and Finish	See Table I				
Size Code	05, 06, 11, 07, 08, 09, 10, 12, 13, 14, 17; See Table II				
Cable Entry Size	01, 02, 03, 04, 05, 06, 07, 08, 09, 10, 11, 12, 13, 14; See Table III				
Band Option	B = 601-060 flat band supplied K = 601-061 pre-coiled band supplied Omit = no band supplied				

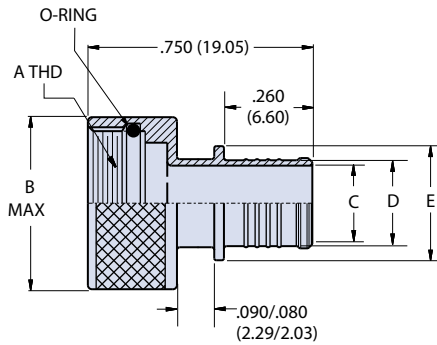

Table I: Material and Finish			
Sym	Description	Sym	Description
M	Aluminum / Electroless Nickel	ZNU	Aluminum / Zinc-Nickel / Black Over Electroless Nickel
NF	Aluminum / Cadmium with Olive Drab	MT	Aluminum / Nickel-PTFE
ZN	Aluminum / Zinc-Nickel with Olive Drab Chromate	Z1	Stainless Steel / Passivated

Table II: Size Code Dimensions and Reference					
Adapter Size Code	Shell Size Reference		A Threads	B Max.	Use with Cable Entry Size Codes
	800, 801, 803, 804	805			
05	5	N/A	.2500-32 UNEF-2B	.350 (8.89)	01 thru 03
06	6	N/A	.3125-32 UNEF-2B	.415 (10.54)	01 thru 04
11	N/A	8	.375-32 UNEF-2B	.465 (11.81)	01 thru 04
07	7	9	.4375-28 UNEF-2B	.530 (13.46)	02 thru 06
08	8	10	.5000-28 UNEF-2B	.595 (15.11)	03 thru 07
09	9	11	.5625-24 UNEF-2B	.650 (16.51)	05 thru 08
10	10	12	.6250-24 UNEF-2B	.715 (18.16)	06 thru 09
12	11, 12, 13	13	.6875-24 UNEF-2B	.785 (19.94)	07 thru 10
13	N/A	15	.750-20 UNEF-2B	.830 (21.08)	07 thru 10
14	14, 15, 16, 17	18, 19	.9375-20 UNEF-2B	1.020 (25.91)	10 thru 15
16	19	21	1.0625-18 UNEF-2B	1.155 (29.34)	10 thru 16
17	21	23	1.1875-18 UNEF-2B	1.280 (32.51)	10 thru 17

Table III: Banding Platform and Cable Entry Dimensions			
Cable Entry Code	Ø C ± .015 (± 0.38)	Ø D ± .015 (± 0.38)	Ø E ± .015 (± 0.38)
01	.094 (2.39)	.133 (3.38)	.235 (5.97)
02	.125 (3.18)	.164 (4.17)	.266 (6.76)
03	.172 (4.37)	.211 (5.36)	.313 (7.95)
04	.234 (5.94)	.273 (6.93)	.375 (9.52)
05	.272 (6.91)	.311 (7.90)	.413 (10.49)
06	.312 (7.92)	.351 (8.92)	.453 (11.51)
07	.375 (9.52)	.414 (10.52)	.516 (13.11)
08	.438 (11.13)	.477 (12.12)	.579 (14.71)
09	.500 (12.70)	.539 (13.69)	.641 (16.28)
10	.562 (14.27)	.601 (15.27)	.703 (17.86)
11	.625 (15.88)	.664 (16.87)	.766 (19.46)
12	.688 (17.48)	.727 (18.47)	.829 (21.06)
13	.750 (19.05)	.789 (20.04)	.891 (22.63)
14	.812 (20.62)	.851 (21.62)	.953 (24.21)
15	.875 (22.23)	.914 (23.22)	1.016 (25.81)
16	.938 (23.83)	.977 (24.82)	1.079 (27.41)
17	1.000 (25.40)	1.039 (26.39)	1.141 (28.98)

ACCESSORIES, BACKSHELLS, AND TOOLS