

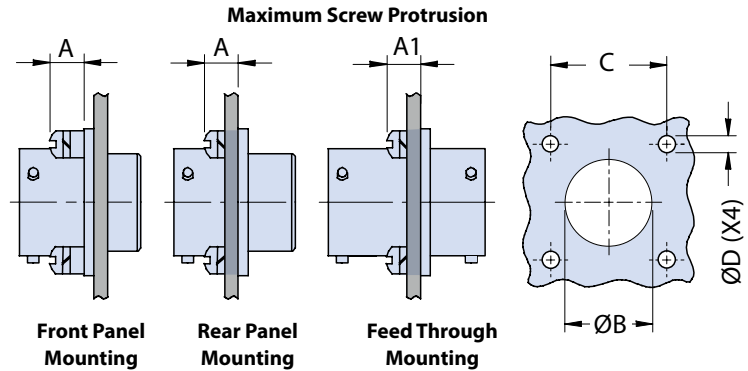

Glenair IPT Series Bayonet-Lock Signal Connectors (MIL-DTL-26482 Serie I) Fastener Height Requirements and Panel Cutout Dimensions

For front panel mount square flange connectors (00) the "A" dimension indicates the measured maximums that mounting hardware can stand proud from the connector flange before it will interfere with connector mating. For rear box mount square flange connectors (02) the same "A" column maximum dimensions apply, but in this case the measurement taken includes the thickness of the panel wall or box (so the mounting hardware needs to be correspondingly shorter). Column "A1" defines the max dimensions for the bulkhead feedthrough (02PP) before mounting hardware interferes with mating.



Panel thickness and panel cutout						
Shell Size	A max	A1 max	ØB +0.2 / -0		C ±0.1	ØD ±0.12
			Front Panel	Rear Panel		
8	2.2	5.54	12.7	15.0	15.10	3.04
10	2.2	5.54	16.0	18.0	18.25	3.04
12	2.2	5.54	19.0	22.5	20.60	3.04
14	2.2	5.54	22.2	25.7	23.00	3.04
16	2.2	5.54	25.5	29.0	24.60	3.04
18	2.2	5.54	28.5	32.0	27.00	3.04
20	5.4	8.74	31.7	35.2	29.35	3.04
22	5.4	8.74	35.0	38.5	31.75	3.04
24	5.4	7.9	38.0	41.6	34.90	3.73

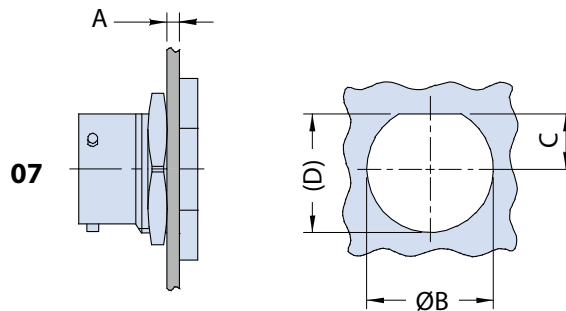

Panel thickness and panel cutout for Jam Nut connectors				
Shell Size	A min - max	ØB +0.2 / -0	C +0 / -0.25	(D)
8	1.6 - 3.2	14.5	6.35	13.6
10	1.6 - 3.2	17.7	7.95	16.8
12	1.6 - 3.2	22.7	9.55	20.9
14	1.6 - 3.2	25.7	11.25	24.1
16	1.6 - 3.2	28.8	12.80	27.2
18	1.6 - 3.2	32.0	14.40	30.4
20	1.6 - 6.3	35.1	16.10	33.6
22	1.6 - 3.2	38.4	17.6	36.8
24	1.6 - 3.2	41.5	19.25	40.0