

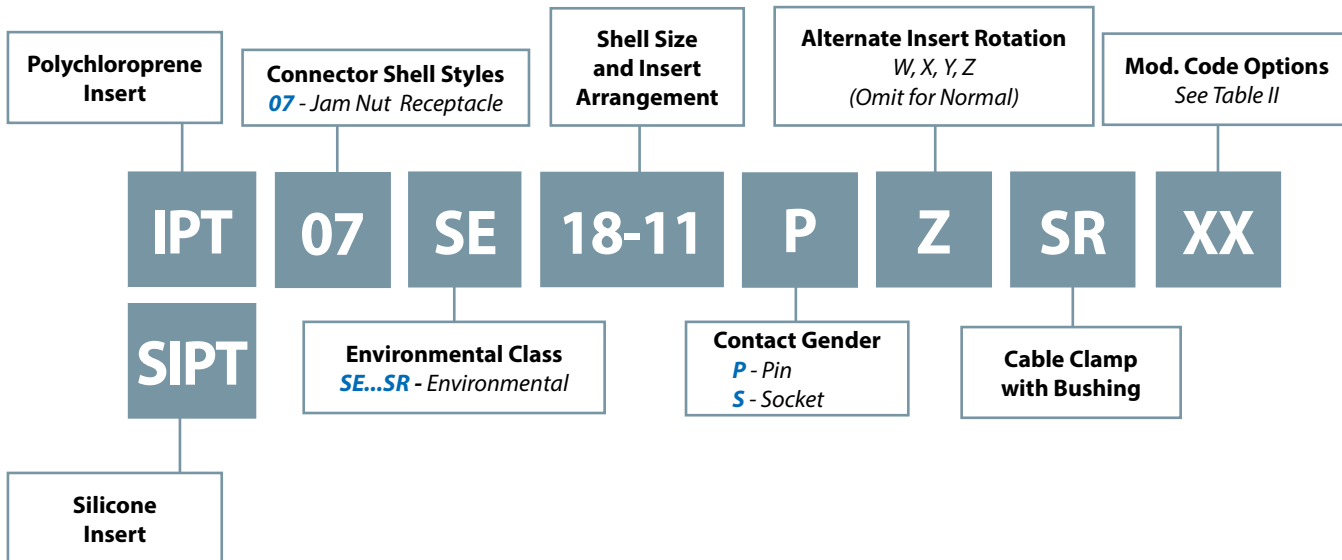

IPT 07 SE...SR
Jam Nut Receptacle
Connector and Backshell with Cable Clamp and Bushing

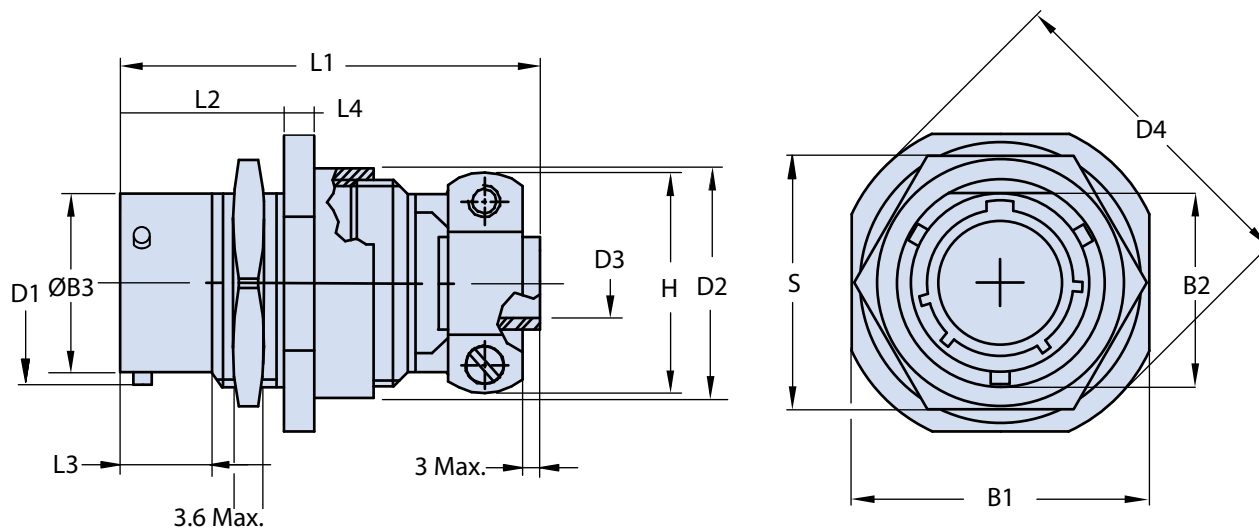

B



Application Notes

1. Jam nut receptacle connector with shrink boot backshell.
2. Connector/Backshell Class "SE...SR" (environmental).
3. Standard materials configuration consists of aluminum alloy with stainless steel coupling pins.
4. Standard contact material consists of copper alloy with gold plating over nickel.
5. A broad range of other front and rear connector accessories are available. See our website and/or contact factory for complete information.
6. Standard insert is high insulation synthetic rubber.

IPT 07 SE...SR
Jam Nut Receptacle
Connector and Backshell with Cable Clamp and Bushing

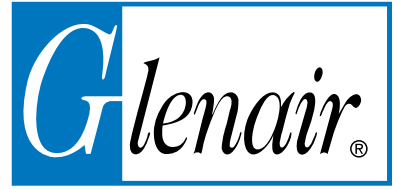

TABLE I: DIMENSIONS

Shell size	B1 Max.	B2 +0 -0.25	ØB3 +0 -0.1	D1	D2 Min.	D3 +0.3 -0.7	D4 +0 -0.8	H ± 0.2	L1 Max.	L2 +0.8 -0	L3 Min.	L4 ±0.15	S ±0.43
8	24.3	13.46	12.00	0.5625 - 24 UNEF	19.0	3.2	27.3	19.10	61.5	17.5	9.75	3.0	19.05
10	27.4	16.64	14.98	0.6875 - 24 UNEF	22.2	4.8	30.5	20.70	61.5	17.5	9.75	3.0	22.23
12	32.2	20.78	19.05	0.8750 - 20 UNEF	25.4	7.9	35.3	23.90	61.5	17.5	9.75	3.0	26.97
14	35.4	23.93	22.22	1.0000 - 20 UNEF	28.5	9.5	38.5	27.00	61.5	17.5	9.75	3.0	30.18
16	38.6	27.08	25.40	1.1250 - 18 UNEF	31.7	12.7	41.6	28.60	64.4	17.5	9.75	3.0	33.32
18	41.7	30.25	28.57	1.2500 - 18 UNEF	34.9	15.9	44.8	35.00	64.4	17.5	9.75	3.0	36.53
20	46.5	33.43	31.75	1.3750 - 18 UNEF	38.8	15.9	49.6	35.00	71.1	22.3	11.32	3.8	39.67
22	49.7	36.60	34.85	1.5000 - 18 UNEF	42.0	19.1	52.7	39.75	71.1	22.3	11.32	3.8	42.88
24	52.8	39.78	38.10	1.6250 - 18 UNEF	45.2	20.3	55.9	42.10	73.6	23.1	12.16	3.8	46.02

B

TABLE II: MODIFICATION CODES

CONTACT OPTIONS	
Sym	Description
B0	Connector Without Contacts (Only for crimp version)
FINISH OPTIONS	
Sym	Description and RoHS compliant
F6	Black Electrodeposited Paint
F7	Black Zinc Nickel
F11	Electroless Nickel
MB	Marine Bronze
Omit for standard version (Cadmium Olive Drab Finish)	