



MIL-DTL-5015 Type Reverse Bayonet Coupling (Series ITS) USB-B Connector

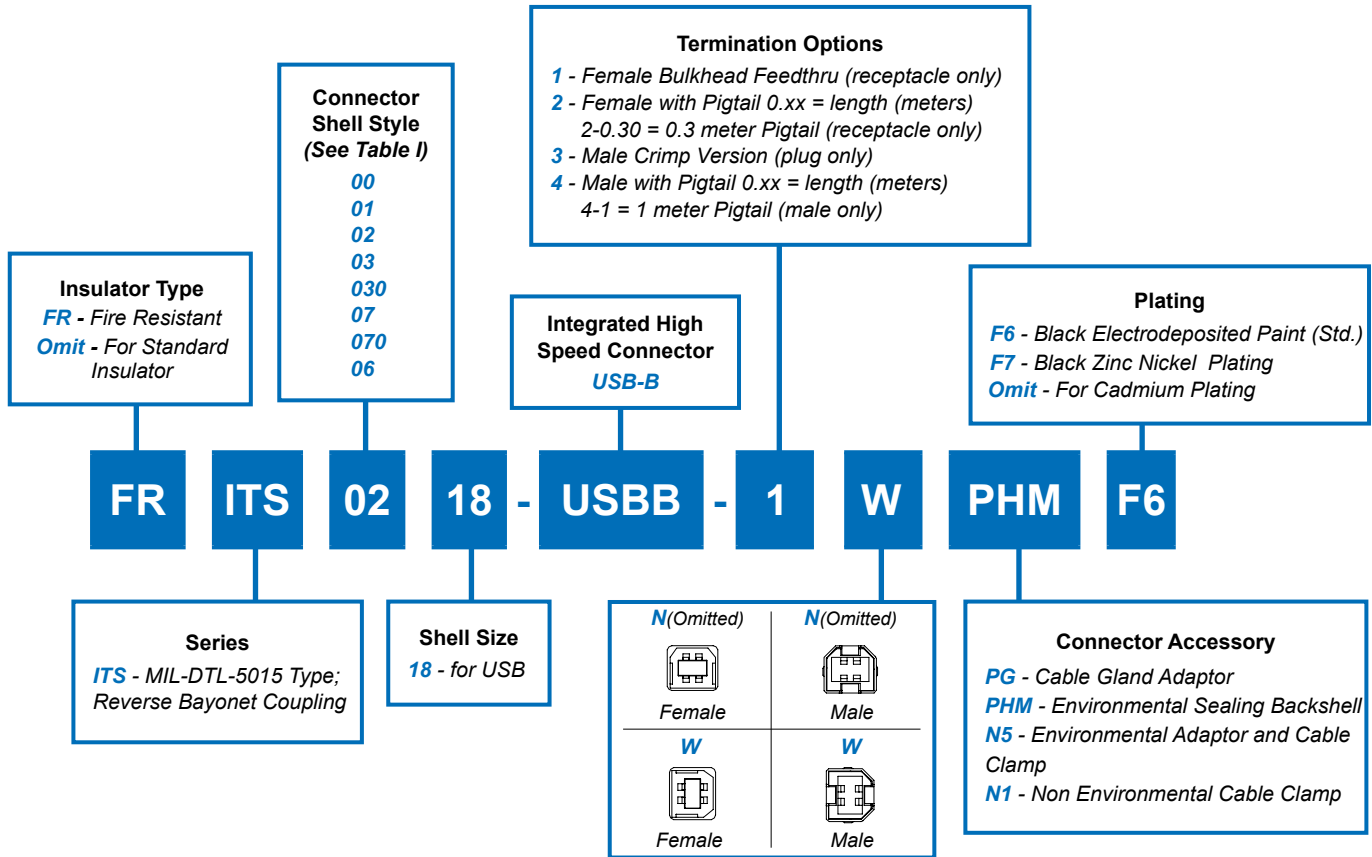

Figure 1
Receptacle (Front)



Figure 2
Plug (Front)



MIL-DTL-5015 Type Reverse Bayonet Coupling (Series ITS) USB-B Connector



TABLE I

**Connector Shell
Detailed Description**

- 00 - Front Panel Mount Square Flange Receptacle with Accessory Threads*
- 01 - In Line Cylindrical Receptacle with Accessory Threads*
- 02 - Front Panel Mount Square Flange Receptacle; No Accessory Threads*
- 03 - Rear Panel Mount Square Flange Receptacle; No Accessory Threads*
- 030 - Rear Panel Mount Square Flange Receptacle with Accessory Threads*
- 07 - Rear Panel Mount Jam Nut Receptacle; No Accessory Threads*
- 070 - Rear Panel Mount Jam Nut Receptacle with Accessory Threads*
- 06 - Straight Cylindrical Plug Connector with Accessory Threads*

Commercial-grade USB-B connectors are intended for use in clean, dry environments. Exposure to dirt and moisture can lead to damage or failure. Glenair's sealed USB-B connectors and feed-thrus provide a high level of protection for the most hostile environments. Standard USB-B connectors are housed in rugged, waterproof ITS and IPT Series bayonet connectors. Connectors feature resilient nitrile inserts and electrodeposited corrosion-resistant black paint or black zinc nickel plating. Cadmium plating is also available. A typical ITS USB-B application consists of a through bulkhead female receptacle (*Figure 1*) and a male plug crimp USB-B (*Figure 2*).

TECHNICAL CHARACTERISTICS

Insert Arrangement	USB Type B
Dielectric Withstanding Voltage	500 Volts AC for 1 minute
Current Rating	1 Amp Max
Max. Contact Resistance	30 mΩ
Min. Insulation Resistance	1.000 mΩ at 500 Volts DC
Working Temperature	-55° to +105° C
Environmental Rating	IP67 (with metal cap)

Assembly Instructions

1. Slide domed nut, rubber bushing, compression fitting and adapter over cable.
2. Strip and prep USB cable.
3. Solder wires to USB Insert.
4. Install USB insert into housing and attach lid.
5. Crimp lid to shield using hex crimp tool.
6. Push assembled USB connector into back side of dielectric; until the metal tab bottoms on the rubber insulator.
7. Install strain relief components and securely tighten.
8. For use with M24758A conduit, remove stock backshell and replace with M24758/29 conduit adapter.



**Solder wires to USB-B
Insert**



**Install insert, attach
lid, and crimp shield**



**Push terminated USB connector
into the dielectric until the tab
bottoms in the notch**



**Attach adapter, fitting,
bushing and nut. Securely
tighten.**



MIL-DTL-5015 Type Reverse Bayonet Coupling (Series ITS) USB-B Connector

CONFIGURATIONS AVAILABLE : ITS 00

Front View

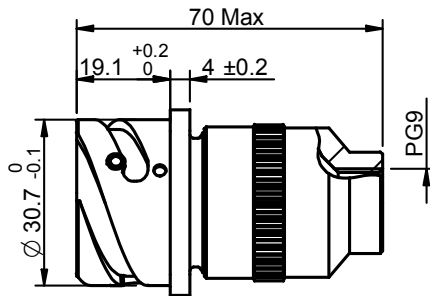
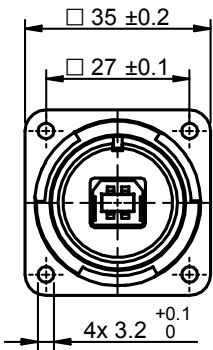

FRITS0018-USBB-1PGF6

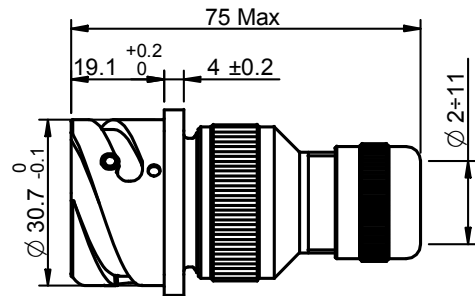

FRITS0018-USBB-1PHMF6

Front View

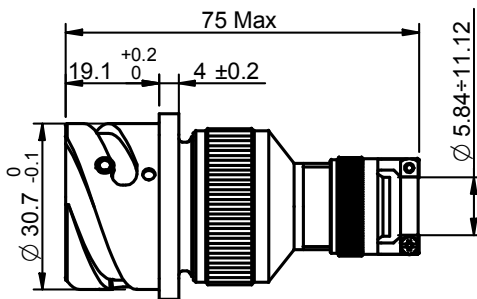
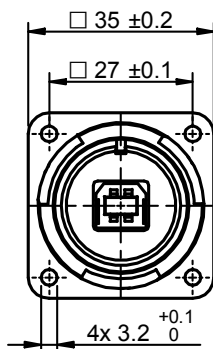

FRITS0018-USBB-1N5F6

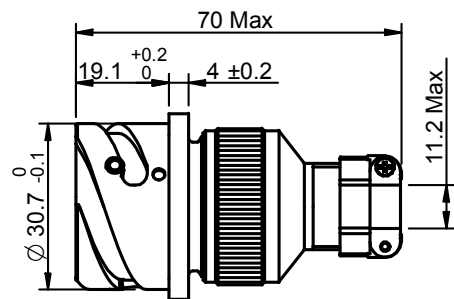

FRITS0018-USBB-1N1F6

CONFIGURATIONS AVAILABLE : ITS 01

Front View

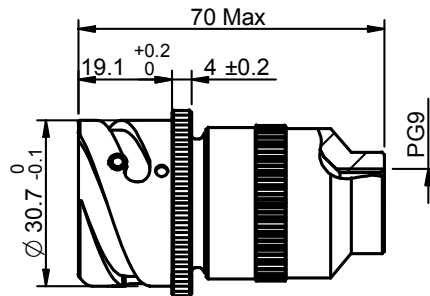
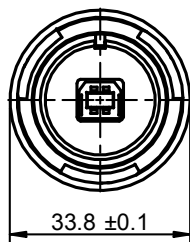

FRITS0118-USBB-1PGF6

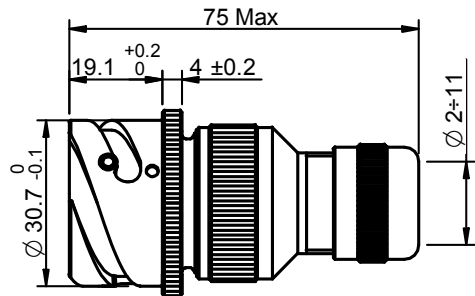

FRITS0118-USBB-1PHMF6

MIL-DTL-5015 Type Reverse Bayonet Coupling (Series ITS) USB-B Connector



High-Speed
Connectors

CONFIGURATIONS AVAILABLE : ITS 01

Front View

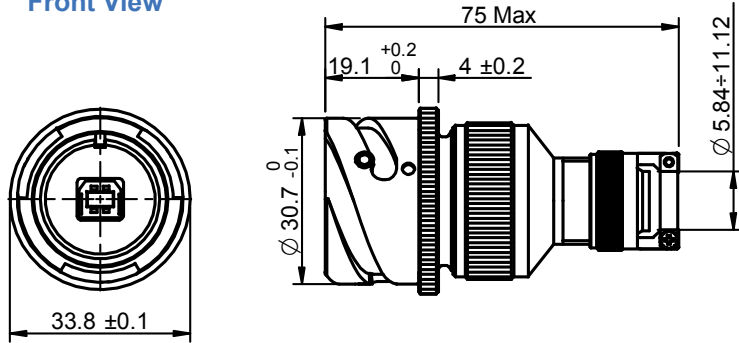

FRITS0118-USB-1N5F6

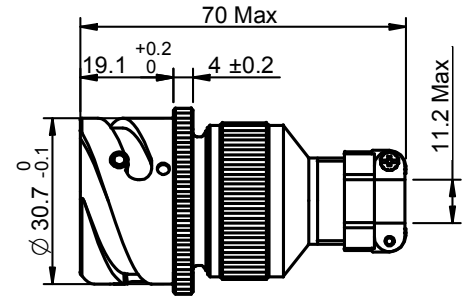

FRITS0118-USB-1N1F6

CONFIGURATIONS AVAILABLE : ITS 030

Front View

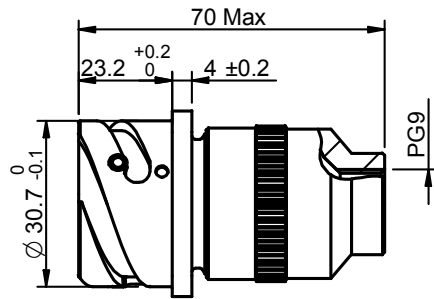
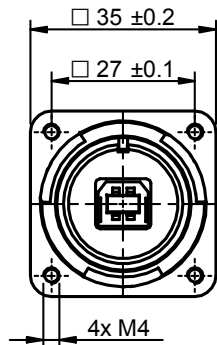

FRITS03018-USB-1PGF6

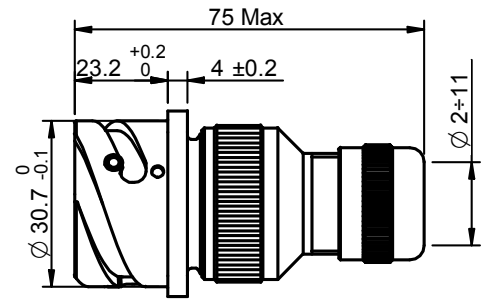

FRITS03018-USB-1PHMF6

Front View

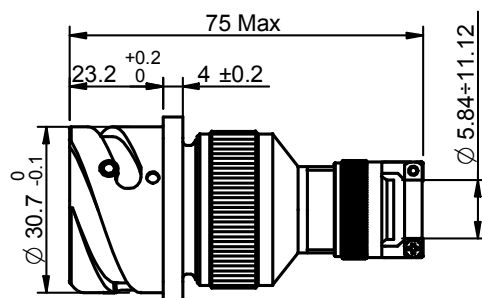
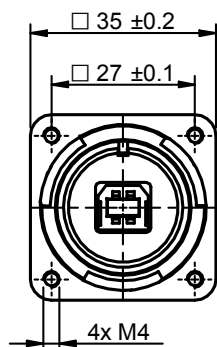

FRITS03018-USB-1N5F6

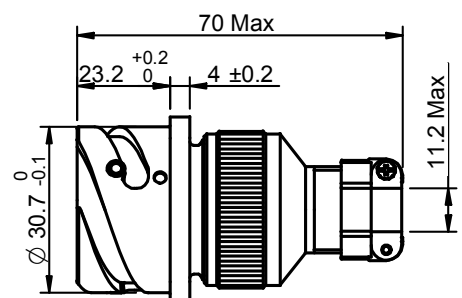

FRITS03018-USB-1N1F6

Connectors



MIL-DTL-5015 Type Reverse Bayonet Coupling (Series ITS) USB-B Connector

CONFIGURATIONS AVAILABLE : ITS 070

Front View

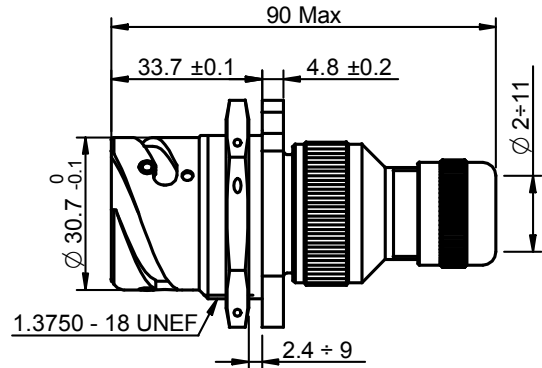
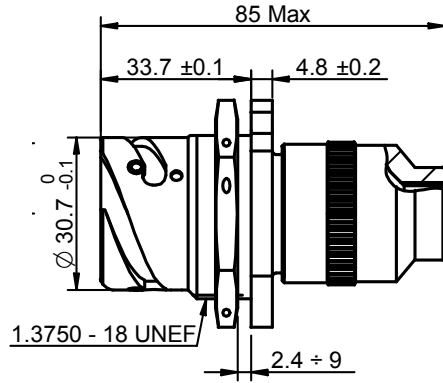
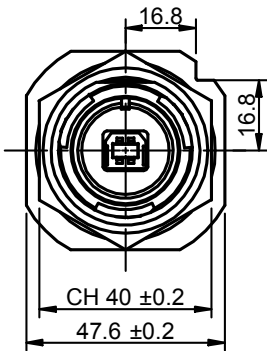

FRITS07018-USBB-1PG F6

FRITS07018-USBB-1PHM F6

Front View

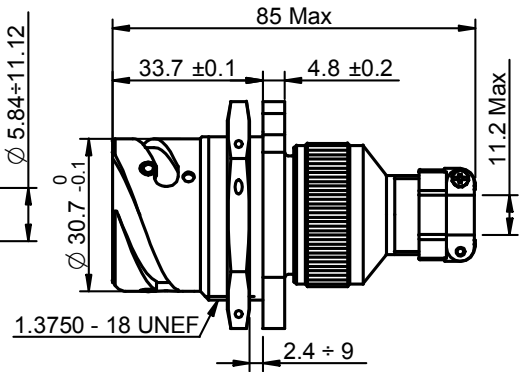
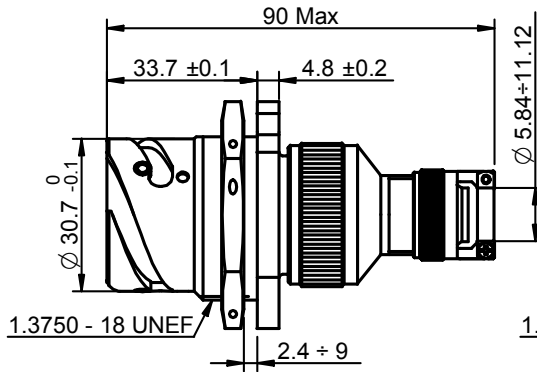
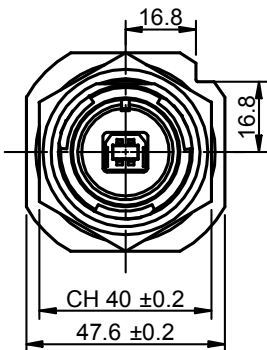

FRITS07018-USBB-1N5F6

FRITS07018-USBB-1N1F6

CONFIGURATIONS AVAILABLE : ITS 06

Front View

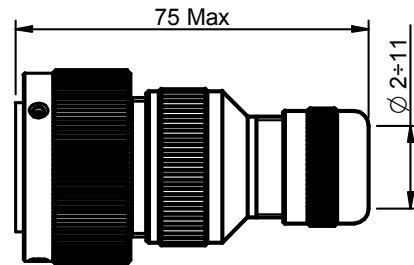
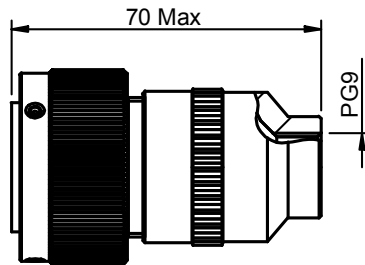
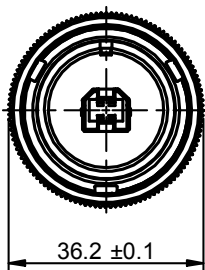

FRITS0618-USBB-3PGF6

FRITS0618-USBB-3PHMF6

MIL-DTL-5015 Type Reverse Bayonet Coupling
(Series ITS)
USB-B Connector



High-Speed
Connectors

CONFIGURATIONS AVAILABLE : ITS 06

Front View

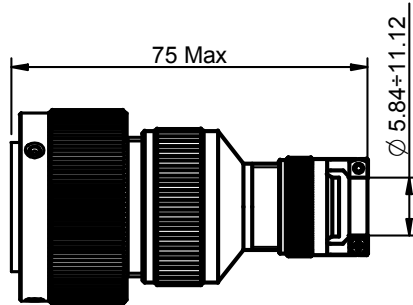
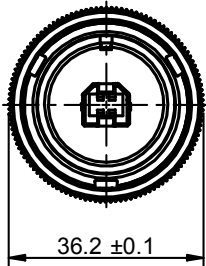

FRITS0618-USBB-3N5F6

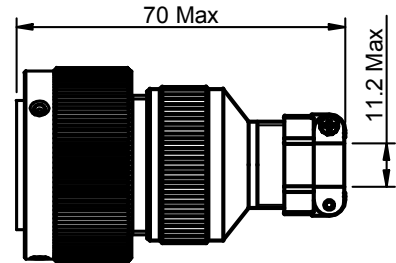

FRITS0618-USBB-3N1F6

Connectors

CONFIGURATIONS AVAILABLE : ITS 02

Front View

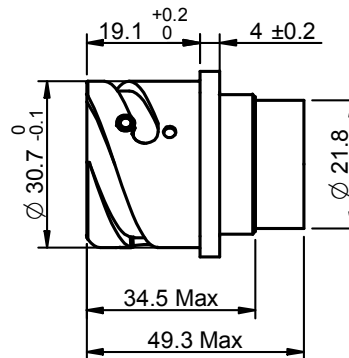
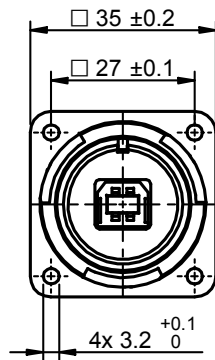

FRITS0218-USBB-1F6



MIL-DTL-5015 Type Reverse Bayonet Coupling
(Series ITS)
USB-B Connector

CONFIGURATIONS AVAILABLE : ITS 03

Front View

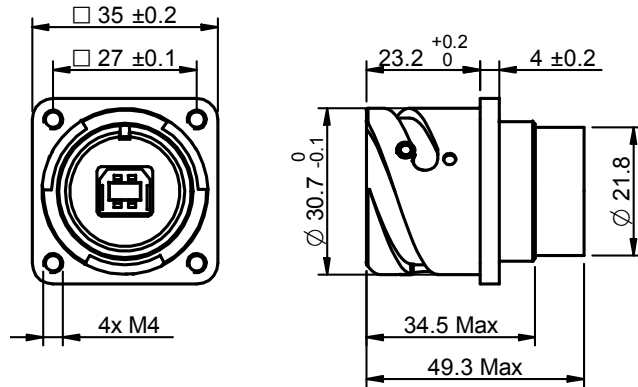

FRITS0318-USB-1F6

CONFIGURATIONS AVAILABLE : ITS 07

Front View

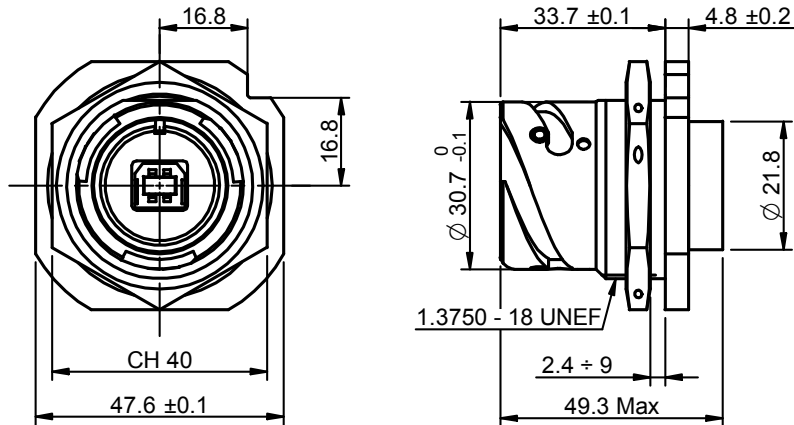

FRITS0718-USB-1F6

MIL-DTL-5015 Type Reverse Bayonet Coupling (Series ITS) USB-B Connector



PIGTAIL GENERAL SKETCHES AND CONFIGURATIONS AVAILABLE

Female with Pigtail for Configuration : 00 - 01 - 030 - 070

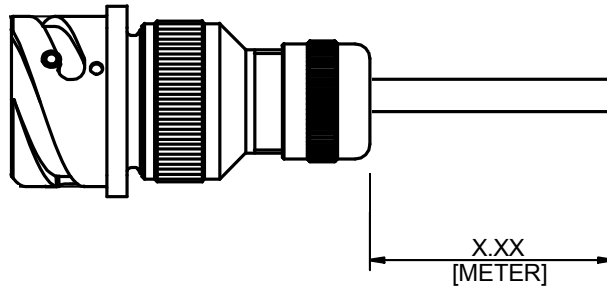

EXAMPLE : FRITS0018-USBB-21.5PHMF6 → 1.5 mt Pigtail

Female with Pigtail for Configuration : 00
FRITS0018-USBB-2X.xxN1F6
FRITS0018-USBB-2X.xxN5F6
FRITS0018-USBB-2X.xxPHMF6
FRITS0018-USBB-2X.xxPGF6

Female with Pigtail for Configuration : 030
FRITS03018-USBB-2X.xxN1F6
FRITS03018-USBB-2X.xxN5F6
FRITS03018-USBB-2X.xxPHMF6
FRITS03018-USBB-2X.xxPGF6

Female with Pigtail for Configuration : 01
FRITS0118-USBB-2X.xxN1F6
FRITS0118-USBB-2X.xxN5F6
FRITS0118-USBB-2X.xxPHMF6
FRITS0118-USBB-2X.xxPGF6

Female with Pigtail for Configuration : 070
FRITS07018-USBB-2X.xxN1F6
FRITS07018-USBB-2X.xxN5F6
FRITS07018-USBB-2X.xxPHMF6
FRITS07018-USBB-2X.xxPGF6

Male with Pigtail for Configuration : 06

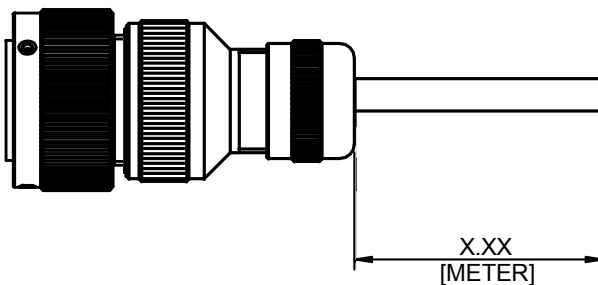

Female with Pigtail for Configuration : 06
FRITS0618-USBB-4X.xxN1F6
FRITS0618-USBB-4X.xxN5F6
FRITS0618-USBB-4X.xxPHMF6
FRITS0618-USBB-4X.xxPGF6

EXAMPLE : FRITS0618-USBB-41.5PHMF6 → 1.5 mt Pigtail