

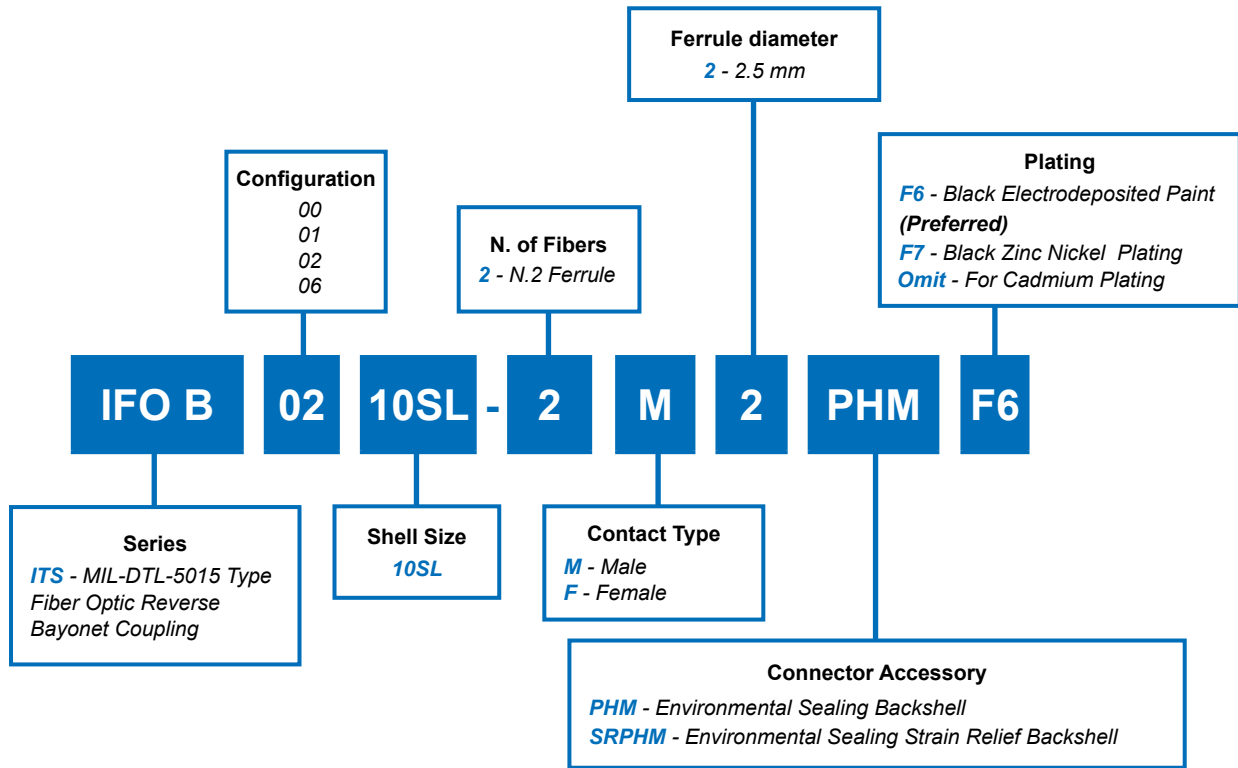

MIL-DTL-5015 and VG95234 Type
(Series IFO)
2 Pole Fiber Optic Connector



MIL-DTL-5015 and VG95234 Type (Series IFO) 2 Pole Fiber Optic Connector



- MIL-DTL-5015 and VG95234 Size 10SL.
- PHM Backshells for jacketed cables.
- SR PHM Strain Relief Backshells for jacketed cables.
- Metal cover for fiber protection.
- Long Backshell for fiber bending prevention.

CONNECTOR TECHNICAL CHARACTERISTICS	
Connection	Fiber Optic
Fiber Type	9/125 - 50/125 - 62/125
Insertion Loss [DB]	≤ 1.4 dB
Working Temperature	-25° to +85° C
Flammability	UL94-V0
Insert	Thermoplastic Resin
Metallic Parts	Aluminium Alloy; Black Electrodeposited Paint *
Mating Cycles	500 Cycles
Environmental Rating	IP67 (mated)
Gaskets and Bushings	Polychloroprene and Silicone Rubber

* RoHS compliant

Optical Contacts

OPTICAL CONTACT TECHNICAL CHARACTERISTICS	
Optical Contacts	Zirconia Ferrules
	Stainless Steel Springs
	Zirconia split sleeves
Ferrule Diameter	2.5 mm

Male Contact

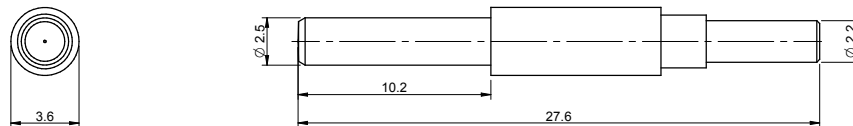

Female Contact

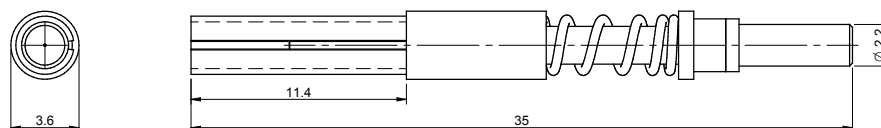

MIL-DTL-5015 and VG95234 Type
(Series IFO)
2 Pole Fiber Optic Connector

Front View

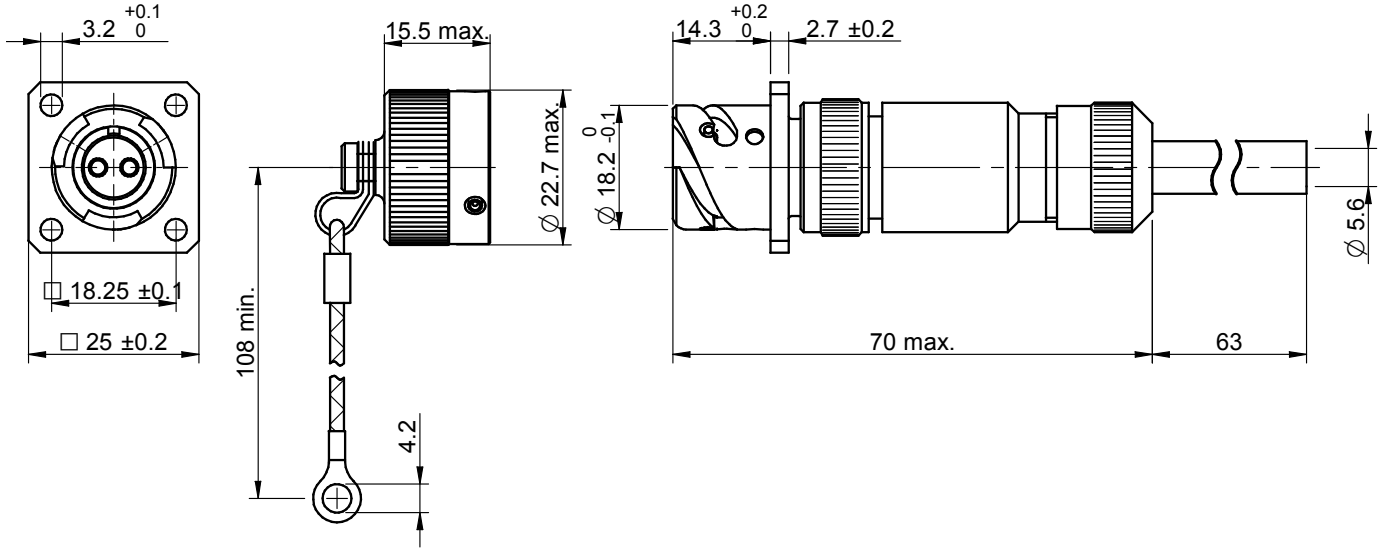

IFOB0010SL-2...2PHMF6

Front View

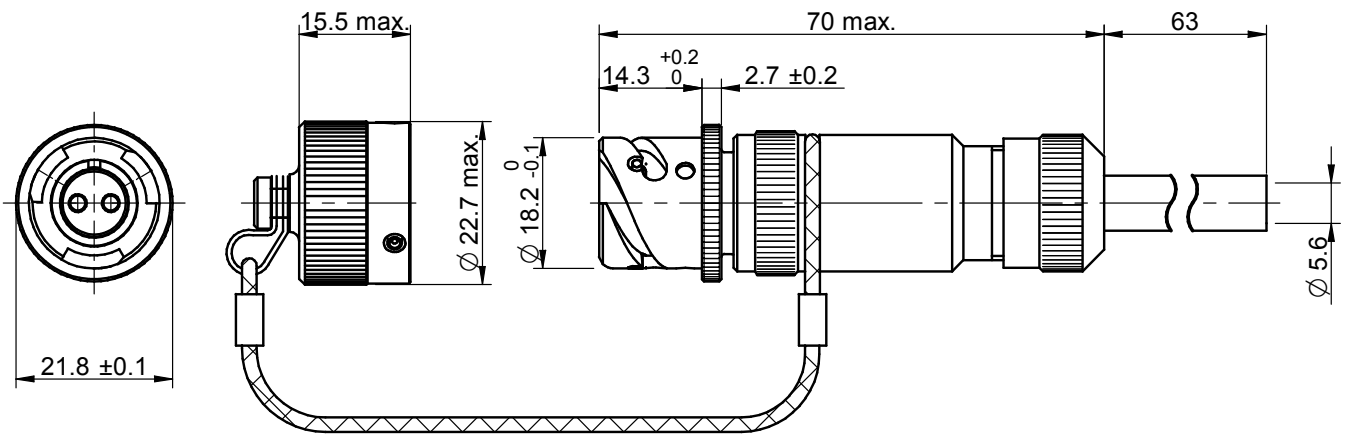

IFOB0110SL-2...2PHMF6

MIL-DTL-5015 and VG95234 Type
(Series IFO)
2 Pole Fiber Optic Connector



Front View

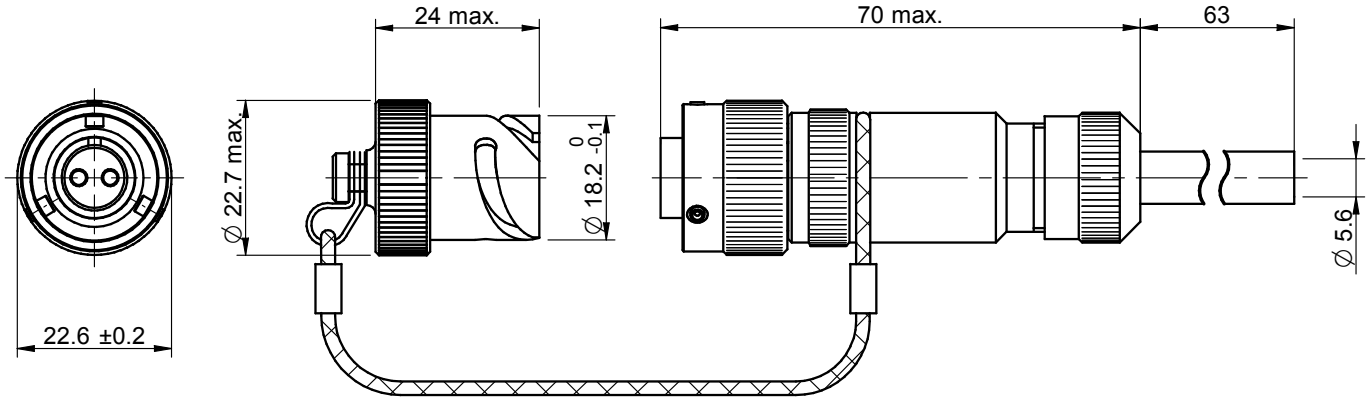

IFOB0610SL-2...2PHMF6

Front View

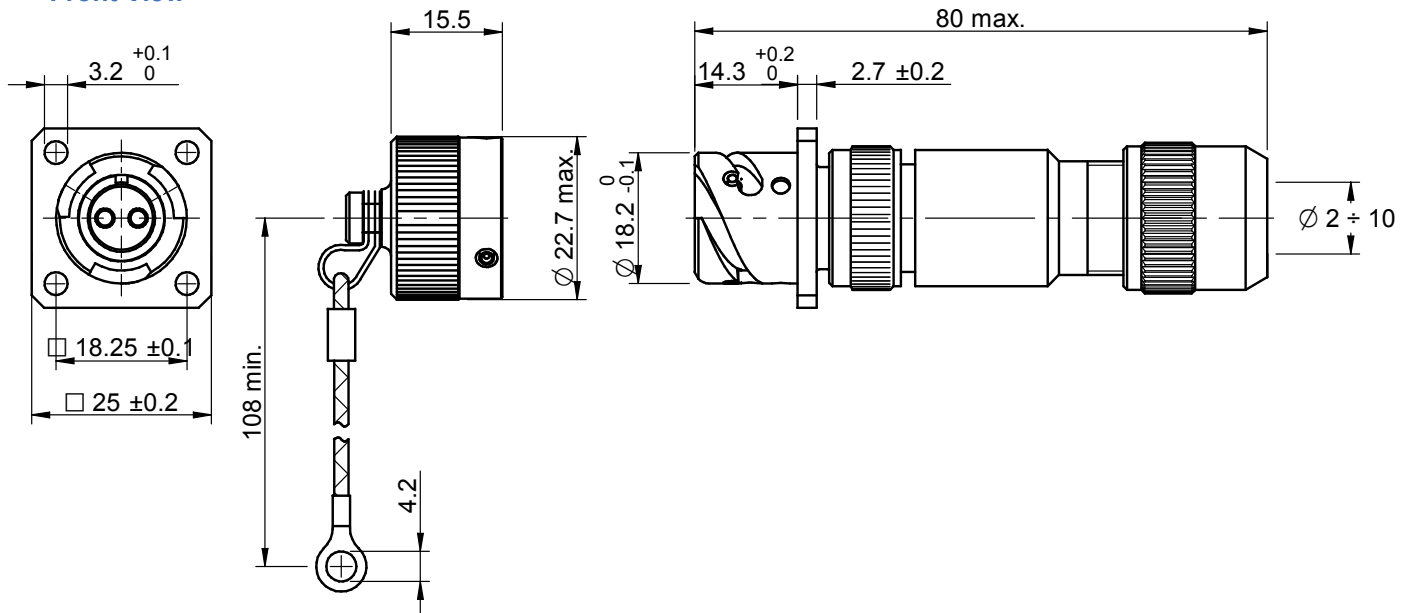

IFOB0010SL-2...2SRPHMF6

MIL-DTL-5015 and VG95234 Type
(Series IFO)
2 Pole Fiber Optic Connector

Front View

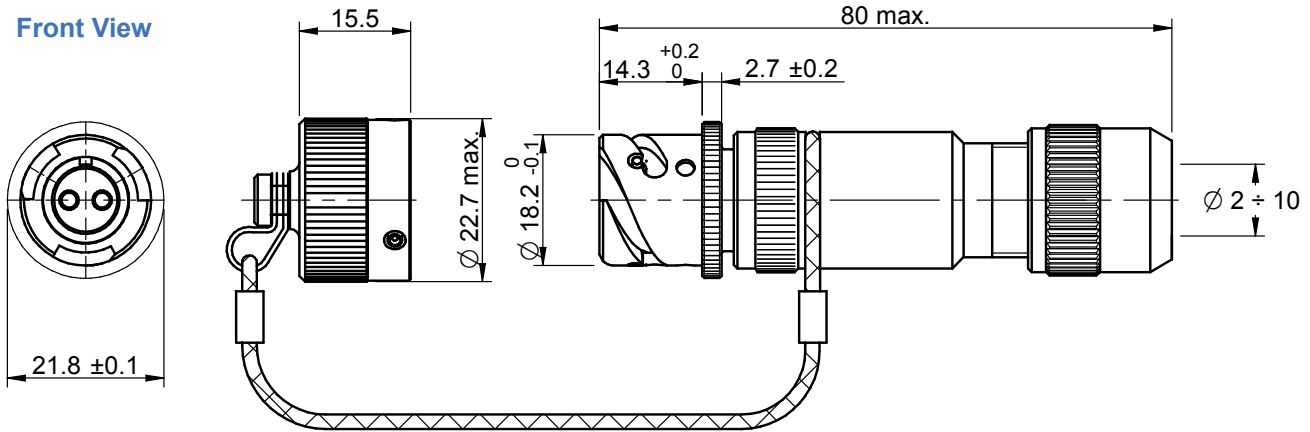

IFOB0110SL-2...2SRPHMF6

Front View

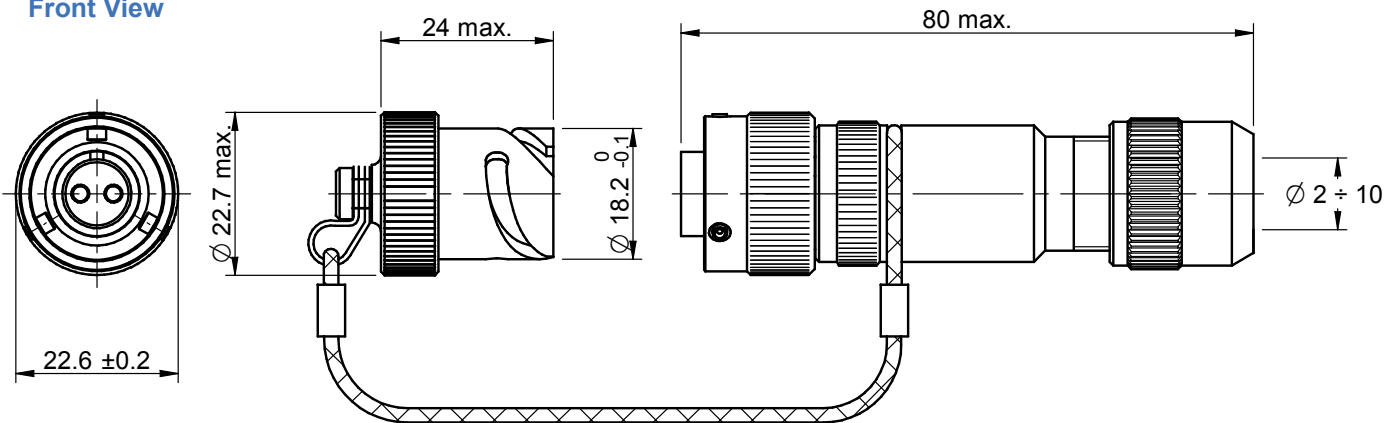

IFOB0610SL-2...2SRPHMF6

MIL-DTL-5015 and VG95234 Type
(Series IFO)
2 Pole Fiber Optic Connector



Front View

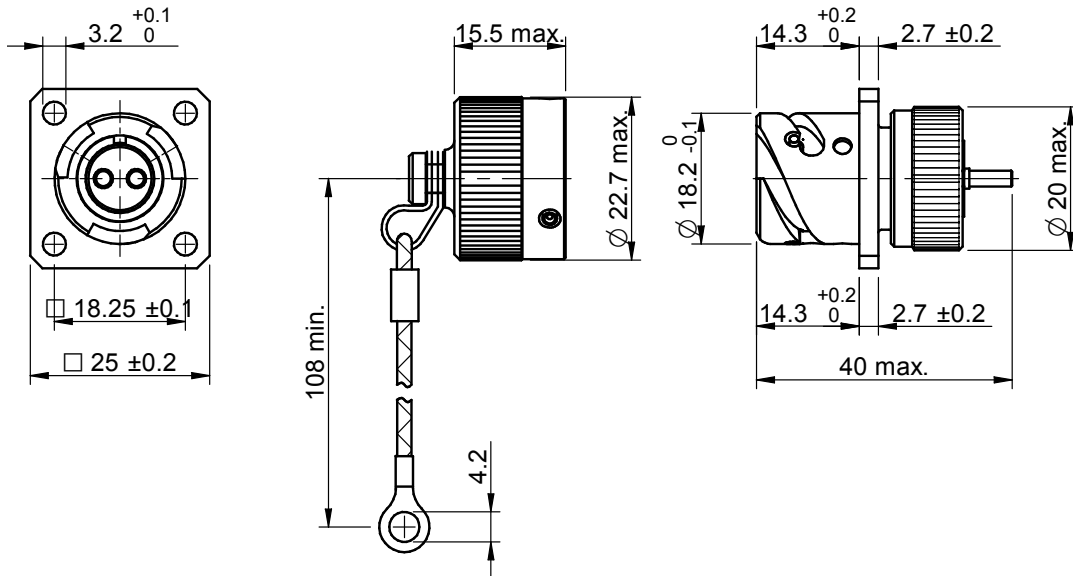

IFOB0210SL-2...2F6