

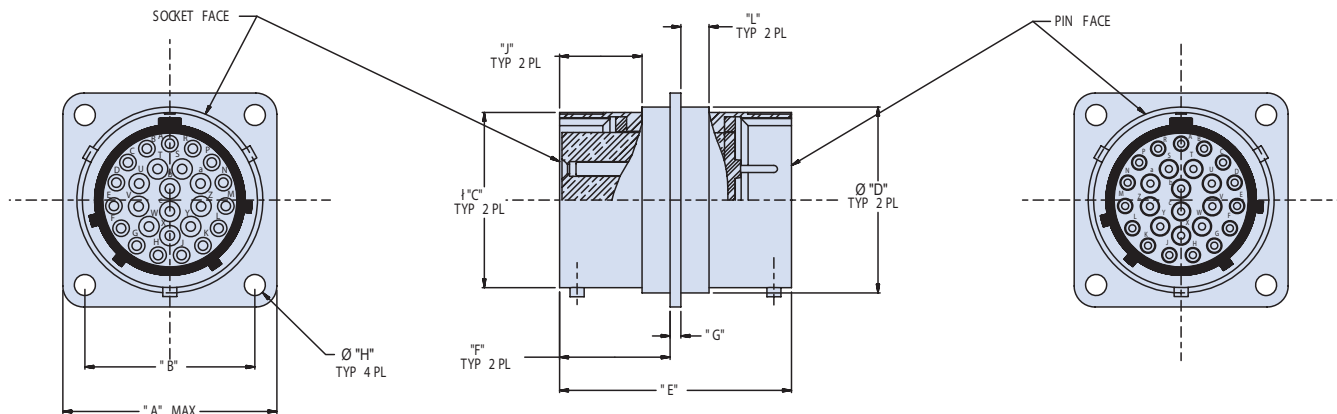

**947-303**  
**Narrow Flange Mount Bulkhead Feed-Thru**  
**MS3440 Type**

**D**

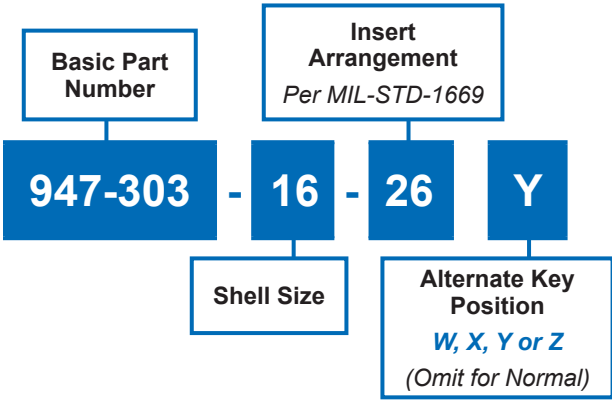

**APPLICATION NOTES**

- To be identified with manufacturer's name, part number and date code, space permitting.
- Material/Finish:  
Shell: 300 CRES / passivate  
Titanium and Inconel® available. Consult factory.  
Contacts, Pin - Nickel alloy / gold plate  
Contacts, Socket - Copper alloy / gold plate  
Hoods, Sockets - 300 series CRES / passivate  
Bayonets - 300 series CRES / passivate  
Insulator - full glass / N.A.  
Insulator, Socket - high grade dielectric / N.A.  
Seals - Silicone elastomer / N.A.
- Glenair 947-303 will meet all performance requirements of MIL-DTL-26482
- Consult factory and/or MIL-STD-1669 for arrangement and insert position options.
- Glenair 947-303 will mate with any QPL manufacturer's MIL-DTL-26482 Series I or II plug with same shell size, arrangement and polarization, having opposite contact gender
- Glenair 947-303 is symmetrical on both sides of flange. There is no need to specify pin or sockets on one end.
- Metric Dimensions (mm) are indicated in parentheses.

**947-303**  
**Narrow Flange Mount Bulkhead Feed-Thru**  
**MS3440 Type**



MIL-DTL-26482  
 Type

**D**

**TABLE I: CONNECTOR AND CUT-OUT DIMENSIONS (Continued Below)**

Shell Size	A	B	C Dia	D Dia ± .010	E Max	F	G	H
8	.828 (21.03)	.594 (15.1)	.474 (12.0) .468 (11.9)	.533 (13.5)	1.462 (37.13)	.692 (17.6) .672 (17.1)	.078 (2.0) .046 (1.2)	.120 (3.0)
10	.954 (24.2)	.719 (18.3)	.591 (15.0) .585 (14.9)	.650 (16.5)	1.462 (37.13)	.692 (17.6) .672 (17.1)	.078 (2.0) .046 (1.2)	.120 (3.0)
12	1.047 (26.6)	.812 (20.6)	.751 (19.1) .745 (18.9)	.810 (20.6)	1.462 (37.13)	.692 (17.6) .672 (17.1)	.078 (2.0) .046 (1.2)	.120 (3.0)
14	1.141 (29.0)	.906 (23.0)	.876 (22.3) .870 (22.1)	.935 (23.7)	1.462 (37.13)	.692 (17.6) .672 (17.1)	.078 (2.0) .046 (1.2)	.120 (3.0)
16	1.234 (31.3)	.969 (24.6)	1.001 (25.4) .995 (25.3)	1.060 (26.9)	1.462 (37.13)	.692 (17.6) .672 (17.1)	.078 (2.0) .046 (1.2)	.120 (3.0)
18	1.328 (33.7)	1.062 (27.0)	1.126 (28.6) 1.120 (28.4)	1.185 (30.1)	1.462 (37.13)	.692 (17.6) .672 (17.1)	.078 (2.0) .046 (1.2)	.120 (3.0)
20	1.453 (36.9)	1.156 (29.4)	1.251 (31.8) 1.245 (31.6)	1.310 (33.3)	1.506 (38.3)	.698 (17.7) .678 (17.2)	.110 (2.8) .078 (2.0)	.120 (3.0)
22	1.578 (40.1)	1.250 (31.8)	1.376 (35.0) 1.371 (34.8)	1.435 (36.4)	1.506 (38.3)	.698 (17.7) .678 (17.2)	.110 (2.8) .078 (2.0)	.120 (3.0)
24	1.703 (43.3)	1.375 (34.9)	1.501 (38.1) 1.495 (38.0)	1.560 (39.4)	1.506 (38.3)	.698 (17.7) .678 (17.2)	.110 (2.8) .078 (2.0)	.147 (3.7)

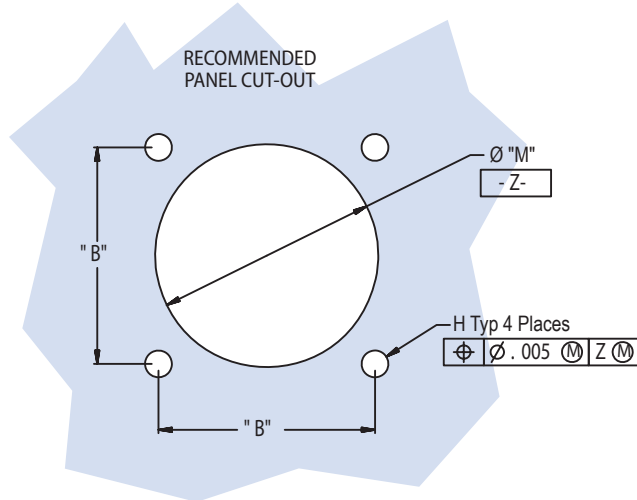

HERMETIC LEAK RATE MOD CODES	
Designator	Required Leak Rate
-585A	1 x 10 <sup>-10</sup> cc Helium per second
-585B	1 x 10 <sup>-9</sup> cc Helium per second
-585C	1 x 10 <sup>-8</sup> cc Helium per second

TABLE I (Continued)			
Shell Size	J Minimum	L	M Dia. ± .005
8	.460 (11.7)	.212 (5.4)	.570 (14.5)
10	.460 (11.7)	.212 (5.4)	.680 (17.3)
12	.460 (11.7)	.212 (5.4)	.789 (20.0)
14	.460 (11.7)	.212 (5.4)	.914 (23.2)
16	.460 (11.7)	.212 (5.4)	1.039 (26.4)
18	.460 (11.7)	.212 (5.4)	1.164 (29.6)
20	.428 (10.9)	.250 (6.4)	1.258 (32.0)
22	.428 (10.9)	.250 (6.4)	1.383 (35.1)
24	.428 (10.9)	.250 (6.4)	1.508 (38.3)