

### SERIES 22 RECEPTACLE IN STANDARD OR SCOOP-PROOF SHELL WITH PIN OR SOCKET CONTACTS



**220-13 Scoop-Proof Shell**

How To Order					
<b>Sample Part Number</b>	<b>220-03</b>	<b>H</b>	<b>24-61</b>	<b>P</b>	<b>N</b>
<b>Series and Shell Style</b>	<b>220-03</b> - Standard <b>220-13</b> - Scoop-Proof				
<b>Class</b>	<b>H</b> = Hermetic				
<b>Shell Size - Insert Arrangement</b>	See page A-6				
<b>Contact Style</b>	<b>P</b> = Pins <b>S</b> = Sockets <b>C</b> = Pin, PC Termination <b>D</b> = Socket, PC Termination				
<b>Polarization</b>	<b>N, 1, 2, 3, 4</b> See page A-6				

**Prior to use, lubricate O-rings with high grade silicone lubricant (Moly-kote M55 or equivalent).**

B

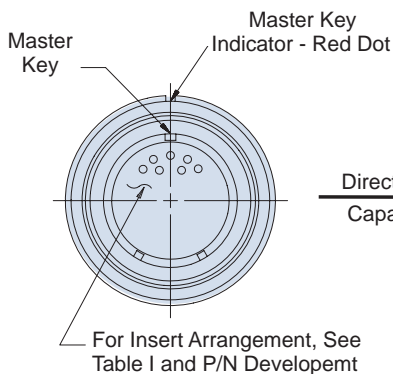

Direction of Pressure Capability - Class H

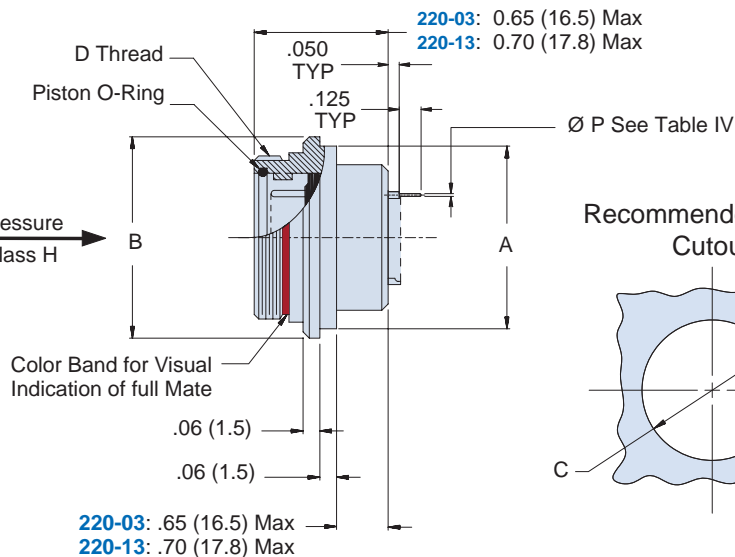

## 220-03 and 220-13 Hermetic Solder Mount Bulkhead Receptacle Front Mount



**Table II: Dimensions**

Shell Size	A Dia Max	B Dia	C Dia +.010 +(0.3) -.000 -(0.0)	D Thread Class 2A
10	.870 (22.1)	1.00 (25.4)	.875 (22.2)	.750 - .1P - .1L
12	.995 (25.3)	1.13 (28.7)	1.000 (25.4)	.875 - .1P - .1L
14	1.120 (28.4)	1.25 (31.8)	1.125 (28.6)	1.000 - .1P - .1L
16	1.245 (31.6)	1.38 (35.1)	1.250 (31.8)	1.125 - .1P - .1L
18	1.370 (34.8)	1.50 (38.1)	1.375 (34.9)	1.250 - .1P - .1L
20	1.495 (38.0)	1.63 (41.4)	1.500 (38.1)	1.375 - .1P - .1L
22	1.620 (41.1)	1.75 (44.5)	1.625 (41.3)	1.500 - .1P - .1L
24	1.745 (44.3)	1.88 (47.8)	1.750 (44.5)	1.625 - .1P - .1L

**Table IV: Contact Dimensions**

Contact Size	Ø P
22D	0.021
	0.018
20	0.024
	0.028
16	0.0635
	0.0615
12	0.095
	0.093

**Table V: Replacement O-Ring Part Numbers \***

Shell Size	Piston O-Ring
10	2-014
12	2-016
14	2-018
16	2-020
18	2-022
20	2-024
22	2-026
24	2-028
* Parker O-ring part numbers. Compound N674-70 or equivalent.	