



240-383E
MIL-DTL-38999 Series III Type Filter Connector
Dual Flange Jam Nut Receptacle with PC Tails

B

D38999 SERIES III TYPE DUAL FLANGE JAM NUT RECEPTACLE WITH PC TAILS

How To Order										
Sample Part Number	240-383	E	ME	15-35	P	P	P	A	N	N
Filter Connector	MIL-DTL-38999 Series III Type									
Shell Style	E = Dual Flange Jam Nut									
Connector Class	See Table I									
Insert Arrangement	IAW MIL-STD-1560. (See pages B-28 – B-29)									
Contact Gender	P = Pin S = Socket									
Termination	P = PC Tail									
Filter Type	P = Pi Circuit C = C Circuit (See Note 1)									
Capacitance	See Table II									
Flange Mounting Style	N = Not Applicable									
Alternate Key Position	A, B, C, D, E, N = Normal (See page B-29)									

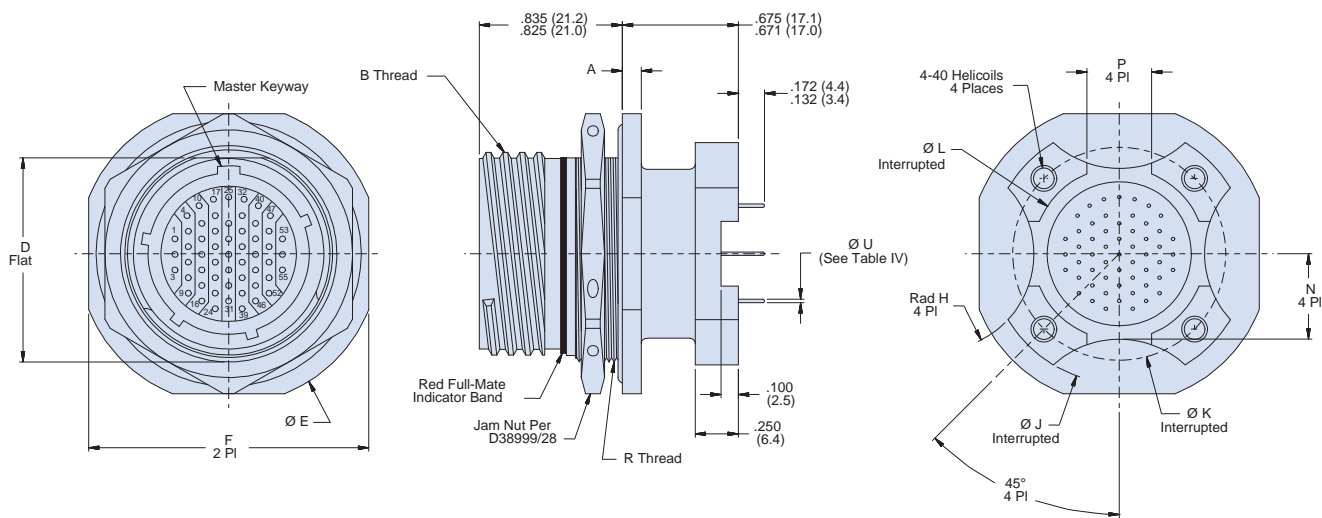

Notes

1. Other filter styles (C-L, L-C, Unbalanced Pi, Multi-Stage, Multi-Value) are available, please consult the factory.

Dimensions in inches (millimeters) and are subject to change without notice.

240-383E
MIL-DTL-38999 Series III Type Filter Connector
Dual Flange Jam Nut Receptacle with PC Tails



MIL-DTL-38999
Type

B

Sym	Class	Material	Finish Description
ME	Environmental	Aluminum	Electroless Nickel
MT	Environmental	Aluminum	Ni-PTFE 1000 Hour Grey™ Nickel Fluorocarbon Polymer
NF	Environmental	Aluminum	Cadmium O.D. Over Electroless Nickel
ZL	Environmental	Stainless Steel	Electro-Deposited Nickel
XM	Environmental	Composite	Electroless Nickel
XMT	Environmental	Composite	Ni-PTFE 1000 Hour Grey™ Nickel Fluorocarbon Polymer
XW	Environmental	Composite	Cadmium O.D. Over Electroless Nickel
ZN	Environmental	Aluminum	Zinc-Nickel, Olive Drab
ZR	Environmental	Aluminum	Zinc Nickel, Black - RoHS
H2*	Hermetic	Stainless Steel	Electro-Deposited Nickel

*Some dimensions do not apply. See drawing 240-383EH2

Class	Pi - Circuit (pF)	C - Circuit (pF)
X*	160,000 - 240,000	80,000 - 120,000
Y*	80,000 - 120,000	40,000 - 60,000
Z*	60,000 - 90,000	30,000 - 45,000
A	38,000 - 56,000	19,000 - 28,000
B	32,000 - 45,000	16,000 - 22,500
C	18,000 - 33,000	9,000 - 16,500
D	8,000 - 12,000	4,000 - 6,000
E	3,300 - 5,000	1,650 - 2,500
F	800 - 1,300	400 - 650
G	400 - 600	200 - 300
J	70-120	35-60

* Filter Classes X, Y and Z are 250 VDC. All others are 500 VDC

Contact Size	Ø U
22D	.021 (0.53)
	.018 (0.46)
20	.031 (0.79)
	.029 (0.74)
16	.042 (1.07)
	.038 (0.97)
12	.096 (2.44)
	.092 (2.34)

Consult Factory for Additional Filter Types, TVS Diodes, and other Custom Configurations.

Shell Size	B Thread	D ±.005 (.13)	Ø E ±.012 (.30)	F ±.016 (.40)	P ±.010 (.25)	R Thread	Ø J ±.005 (.13)	Ø K Bsc	Ø L ±.005 (.13)	Rad H ±.020 (.51)	N ±.020 (.51)	A
9	.6250-.1P-.3L-TS-2A	.650 (16.5)	1.189 (30.2)	1.063 (27.0)	.225 (5.7)	M17 X 1.0-6g 0.100R	1.016 (25.8)	.752 (19.1)	.532 (13.5)	.225 (5.7)	.275 (7.0)	.122 (3.1) .083 (2.1)
11	.7500-.1P-.3L-TS-2A	.750 (19.1)	1.374 (34.9)	1.252 (31.8)	.250 (6.4)	M20 X 1.0-6g 0.100R	1.062 (27.0)	.850 (21.6)	.595 (15.1)	.250 (6.4)	.290 (7.4)	.122 (3.1) .083 (2.1)
13	.8750-.1P-.3L-TS-2A	.937 (23.8)	1.500 (38.1)	1.374 (34.9)	.250 (6.4)	M25 X 1.0-6g 0.100R	1.250 (31.8)	.994 (25.2)	.720 (18.3)	.375 (9.5)	.370 (9.4)	.122 (3.1) .083 (2.1)
15	1.0000-.1P-.3L-TS-2A	1.061 (26.9)	1.626 (41.3)	1.500 (38.1)	.325 (8.2)	M28 X 1.0-6g 0.100R	1.375 (34.9)	1.119 (28.4)	.843 (21.4)	.438 (11.1)	.440 (11.2)	.122 (3.1) .083 (2.1)
17	1.1875-.1P-.3L-TS-2A	1.186 (30.1)	1.752 (44.5)	1.626 (41.3)	.375 (9.5)	M32 X 1.0-6g 0.100R	1.500 (38.1)	1.237 (31.4)	1.000 (25.4)	.562 (14.3)	.495 (12.6)	.122 (3.1) .083 (2.1)
19	1.2500-.1P-.3L-TS-2A	1.311 (33.3)	1.937 (49.2)	1.811 (46.0)	.500 (12.7)	M35 X 1.0-6g 0.100R	1.625 (41.3)	1.379 (35.0)	1.125 (28.6)	.875 (22.2)	.540 (13.7)	.154 (3.9) .114 (2.9)
21	1.3750-.1P-.3L-TS-2A	1.436 (36.5)	2.063 (52.4)	1.937 (49.2)	.562 (14.3)	M38 X 1.0-6g 0.100R	1.750 (44.5)	1.489 (37.8)	1.240 (31.5)	1.170 (29.7)	.625 (15.9)	.154 (3.9) .114 (2.9)
23	1.5000-.1P-.3L-TS-2A	1.561 (39.7)	2.189 (55.6)	2.063 (52.4)	.688 (17.5)	M41 X 1.0-6g 0.100R	1.875 (47.6)	1.619 (41.1)	1.328 (33.7)	1.250 (31.8)	.660 (16.8)	.154 (3.9) .114 (2.9)
25	1.6250-.1P-.3L-TS-2A	1.686 (42.8)	2.311 (58.7)	2.189 (55.6)	.750 (19.1)	M44 X 1.0-6g 0.100R	2.000 (50.8)	1.744 (44.3)	1.453 (36.9)	1.375 (34.9)	.740 (18.8)	.154 (3.9) .114 (2.9)

Dimensions in inches (millimeters) and are subject to change without notice.