



SERIES 77

Metal Shrink Boot Adapters



440-069 Standard Profile, EMI/RFI Adapter with Banding Porch and Self-Locking Rotatable Coupling

How to Order	
Sample Part Number	440 F S 069 M 20 12 -8 B P T
Product Series	440
Connector Designator	See connector designator table
Angular Function	H = 45° J = 90° S = straight
Basic Part Number	069
Finish Symbol	B = cadmium plate, olive drab C = anodize, black G = hard coat, anodic M = electroless nickel NF = cadmium plate, olive drab over electroless nickel
Shell Size	See dimensions table
Cable Entry Dash No.	See dimensions table
Length (S Only)	1/2-inch increments (e.g. 4 = 2 inches)
Band	B = band K = precoiled Omit for none
Polysulfide Option	P = polysulfide Omit for none; see note 6
Shrink Boot	T, T1, H, H1 Omit for none; see cable entry and shrink boot table



Add "T" to Part Number for Standard Boot

Connector Designator	
A	MIL-DTL-5015, -26482, Series II and -83723 Series I and III
F	MIL-DTL-38999 Series I, II
H	MIL-DTL-38999 Series III and IV
L	LN29729
ROTATABLE COUPLING	
SELF-LOCKING	

Shrink Boot Options	
Sym	Description
T	Standard Shrink Boot (* = 1)
T1	Standard precoated with W1 Hot Melt Adhesive (*=1)
H	Zero Halogen Shrink Boot (* = 2)
H1	Zero Hologen with Pre-Coated W1 Hot Melt Adhesive (* = 2)
To re-order boot select symbol code in table. Asterisk indicates code for material type. Substitute code in boot part number reference according to adhesive option in Cable Entry table	

Cable Entry and Shrink Boot					
Dash No.	K Dia	L Dia	M Dia	T or H Std Boot Ref.	T1 or H1 w/ Adhesive Ref.
01	.125 (3.2)	.250 (6.4)	.312 (7.9)	770-003S*11	770-003S*11W1
31	.188 (4.8)	.312 (7.9)	.374 (9.5)	770-003S*11	770-003S*11W1
02	.250 (6.4)	.375 (9.5)	.437 (11.1)	770-003S*12	770-003S*12W1
32	.312 (7.9)	.438 (11.1)	.500 (12.7)	770-003S*12	770-003S*12W1
03	.375 (9.5)	.500 (12.7)	.562 (14.3)	770-003S*12	770-003S*12W1
33	.438 (11.1)	.562 (14.3)	.624 (15.8)	770-001S*04	770-001S*04W1
04	.500 (12.7)	.625 (15.9)	.687 (17.4)	770-001S*04	770-001S*04W1
34	.562 (14.3)	.688 (17.5)	.750 (19.1)	770-001S*04	770-001S*04W1
05	.625 (15.9)	.750 (19.1)	.812 (20.6)	770-001S*04	770-001S*04W1
35	.688 (17.5)	.812 (20.6)	.874 (22.2)	770-001S*04	770-001S*04W1
06	.750 (19.1)	.875 (22.2)	.937 (23.8)	770-001S*05	770-001S*05W1
36	.812 (20.6)	.938 (23.8)	1.000 (25.4)	770-001S*05	770-001S*05W1
07	.875 (22.2)	1.000 (25.4)	1.062 (27.0)	770-001S*05	770-001S*05W1
37	.938 (23.8)	1.062 (27.0)	1.124 (28.5)	770-001S*05	770-001S*05W1
08	1.000 (25.4)	1.125 (28.6)	1.187 (30.1)	770-001S*06	770-001S*06W1
38	1.062 (27.0)	1.188 (30.2)	1.250 (31.8)	770-001S*06	770-001S*07W1
09	1.125 (28.6)	1.250 (31.8)	1.312 (33.3)	770-001S*07	770-001S*07W1
10	1.250 (31.8)	1.375 (34.9)	1.437 (36.5)	770-001S*07	770-001S*07W1
11	1.375 (34.9)	1.500 (38.1)	1.562 (39.7)	770-001S*07	770-001S*07W1
12	1.500 (38.1)	1.625 (41.3)	1.687 (42.8)	770-001S*07	770-001S*07W1
13	1.625 (41.3)	1.750 (44.5)	1.812 (46.0)	770-001S*08	770-001S*08W1
14	1.750 (44.5)	1.875 (47.6)	1.937 (49.2)	770-001S*08	770-001S*08W1
15	1.875 (47.6)	2.000 (50.8)	2.062 (52.4)	770-001S*09	770-001S*09W1
16	2.000 (50.8)	2.125 (54.0)	2.187 (55.5)	770-001S*09	770-001S*09W1

Dimensions					
Shell Size - Conn. Desig.		F	G	H	J
A-F-L	H	Max	Max	Max	Max
08	09	.806 (20.5)	1.038 (26.4)	.906 (23.0)	1.146 (29.1)
10	11	.832 (21.1)	1.064 (27.0)	.966 (24.5)	1.210 (30.7)
12	13	.856 (21.7)	1.088 (27.6)	1.026 (26.1)	1.268 (32.2)
14	15	.882 (22.4)	1.114 (28.3)	1.076 (27.3)	1.330 (33.8)
16	17	.908 (23.1)	1.150 (29.2)	1.136 (28.9)	1.392 (35.4)
18	19	.927 (23.5)	1.190 (30.2)	1.176 (29.9)	1.438 (36.5)
20	21	.953 (24.2)	1.250 (31.8)	1.236 (31.4)	1.500 (38.1)
22	23	.979 (24.9)	1.320 (33.5)	1.296 (32.9)	1.562 (39.7)
24	25	1.004 (25.5)	1.380 (35.1)	1.356 (34.4)	1.625 (41.3)
28		1.197 (30.4)	1.500 (38.1)	1.422 (36.1)	1.654 (42.0)
32		1.280 (32.5)	1.620 (41.1)	1.545 (39.2)	1.777 (45.1)
36		1.294 (32.9)	1.750 (44.5)	1.652 (42.0)	1.844 (46.8)



SERIES 77 Metal Shrink Boot Adapters



440-069 Standard Profile, EMI/RFI Adapter with Banding Porch and Self-Locking Rotatable Coupling

See Pages G-4 and G-5 for Adapter Interface Dimensions

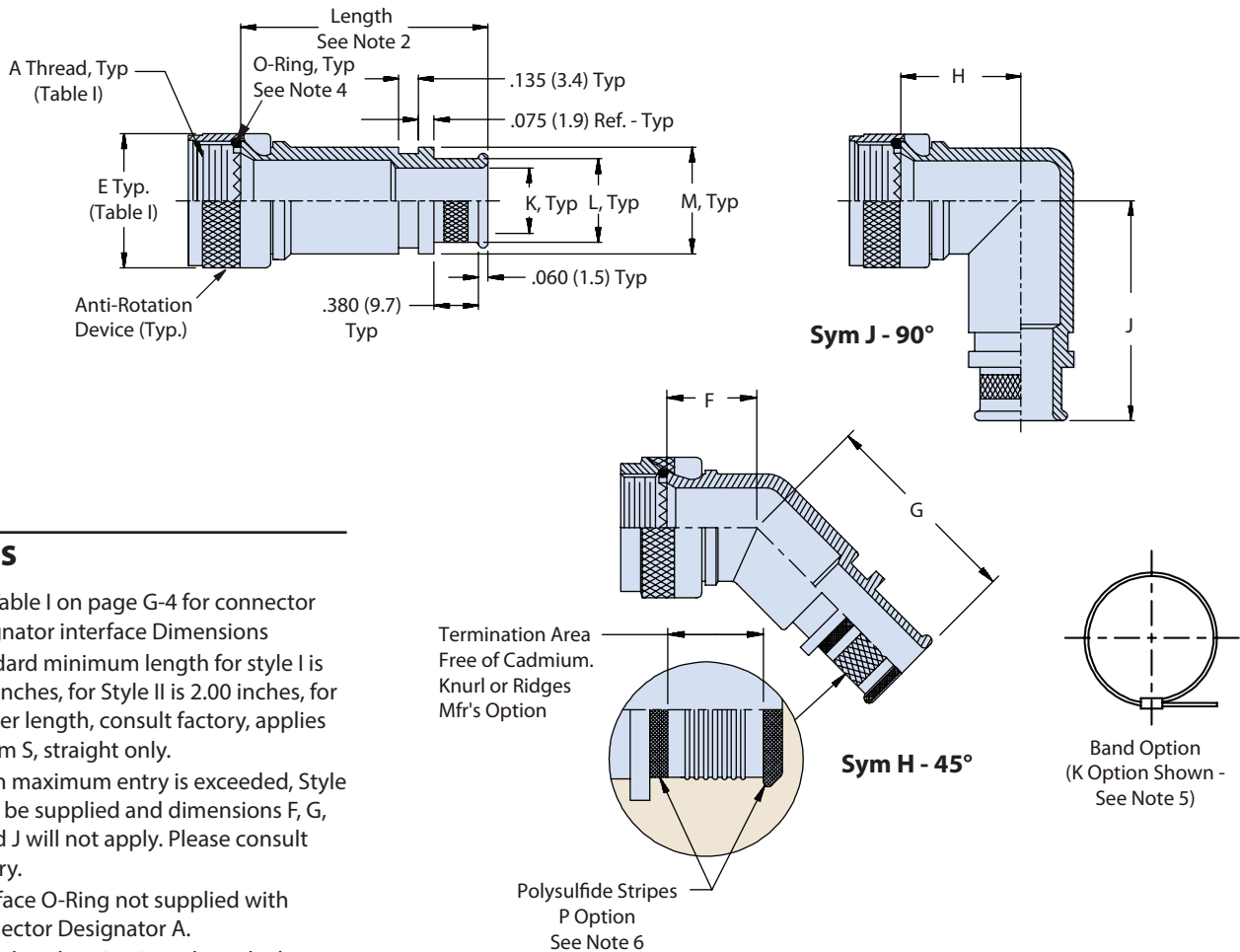

NOTES

1. See Table I on page G-4 for connector designator interface Dimensions
2. Standard minimum length for style I is 1.50 inches, for Style II is 2.00 inches, for shorter length, consult factory, applies to Sym S, straight only.
3. When maximum entry is exceeded, Style II will be supplied and dimensions F, G, H and J will not apply. Please consult factory.
4. Interface O-Ring not supplied with Connector Designator A.
5. When band option is selected adapters will be supplied with 601-040 Band. See Glenair Band-Master ATS Tool Catalog for installation details.
6. When polysulfide barrier is selected shield termination surface will be free of cadmium
7. Standard Boot Kit uses a straight lipped, type 1 material boot without adhesive. For additional material adhesive options order separately from section B
8. Glenair 600 series backshell assembly tools are recommended for assembly and installation
9. Recovered dimension apply to unrestricted recovery. Dimensions may differ than shown when boots are installed over assembly

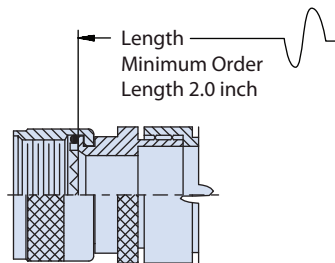

STYLE II
STRAIGHT (SYM S)
(See Note 3)

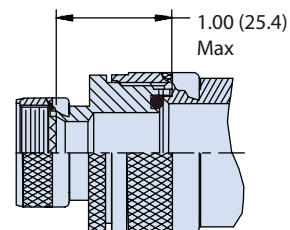

STYLE II
45° & 90°
(See Note 3)

