

710-928 Guardian Transition Aluminum Transition for Annular Convuluted Tubing

Guardian Transition for Glenair Annular Convuluted Tubing

How To Order

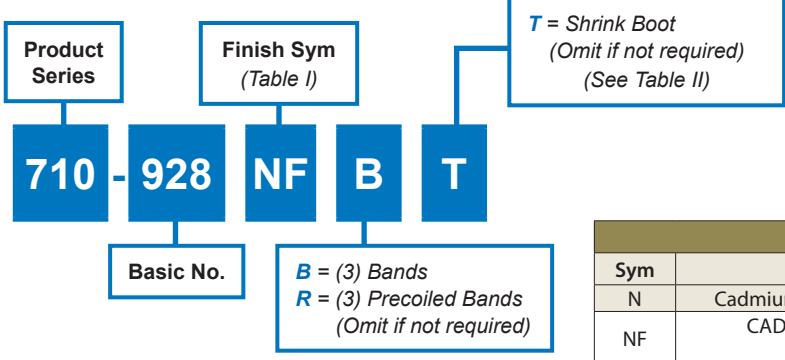

Sym	Finish Description
N	Cadmium Plate/Olive Drab Over Nickel
NF	CAD/O.D. over Electroless Nickel (1000 hr salt spray)
M	Electroless Nickel

Notes

- Glenair 600 series backshell assembly tools recommended
- Conduit retaining clip and conduit O-rings to be supplied un-assembled
- Glenair assembly procedure AP74-010 is recommended for adapter to conduit termination
- Material/Finish:
 - Transition: Aluminum alloy/See Table I
 - Retaining clip: high grade engineering thermoplastic/n.a.
 - O-ring: silicone/N.A.
 - Hardware: Cres/passivated

Entry Size	A Dia		B Dia. Max	Shrink Boot Reference
	Min	Max		
-14	.40 (10.16)	.44 (11.18)	.81 (20.57)	770-001S104
-20	.57 (14.48)	.62 (15.75)	.98 (24.89)	770-001S105

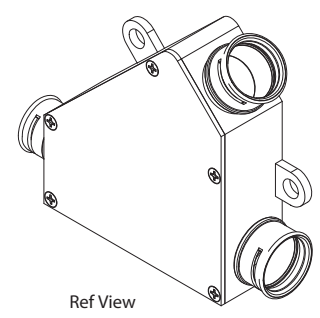
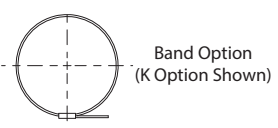

F

