

Swing-Arm® Clamps

for MIL-DTL-38999 Series III and IV Connectors

870H002 Swing-Arm Saddle Clamp, Braid Sock, Composite

Self-Locking

Shielded, self-locking, adjustable arms. 870H002 composite Swing-Arm saddle clamp fits MIL-DTL-38999 Series III and IV connectors. Adjustable arms pivot to 0°, 45° or 90° positions. Supplied with 12 inches (305 mm) of shield braid attached to metal interface ring. Braid choices include 34 AWG nickel/copper, 34 AWG tin/copper, ultralightweight AmberStrand® or microfilament nickel/SST Armorlite®. Corrosion-resistant glass-reinforced thermoplastic meets AS85049 requirements. Full radius saddles have self-locking clinch nuts. Available in two clamp sizes: standard clamp fits most wire bundles, large clamp has increased clearance for oversize wire bundles. Coupling nut has anti-decoupling mechanism for audible detented coupling and prevents backoff under high vibration.



Adapter Code H

This accessory fits these connectors:
MIL-DTL-38999 Series III and Series IV

TABLE 1

INTERFACE RING MATERIAL / FINISH

Aluminum	
M	Electroless Nickel
NF	Olive Drab Cadmium and Electroless Nickel (Figure 1)
MT	Nickel-PTFE
TZ	Tin-Zinc
ZR	Black Zinc-Nickel
Brass	
BM	Electroless Nickel
BN	Olive Drab Cadmium and Electroless Nickel (Figure 1)
BMT	Nickel-PTFE

PART NUMBER

	870H002	BM	21	B	L	K	14			
Base P/N	870H002									
Interface Ring Material/Finish	See Table 1									
Shell Size	Shell Size	9	11	13	15	17	19	21	23	25
	Size Code	09	11	13	15	17	19	21	23	25
Clamp Size	See Clamp Dimensions on next page									
	A	Standard Clamp								
	B	Large Clamp								
Braid Type	N	34 AWG Nickel/Copper Braid								
	T	34 AWG Tin/Copper Braid								
	A	AmberStrand® Nickel/Composite Braid								
	L	Microfilament ArmorLite® Nickel/SST Braid								
Splice Ring and Band	Omit if not required									
	K	Splice ring and standard band								
	J	Splice ring and slim standard band								
Braid Length	Omit for standard 12 inch length									
	14	Length in 1 inch increments, 6 inch min "14" = 14 inches.								

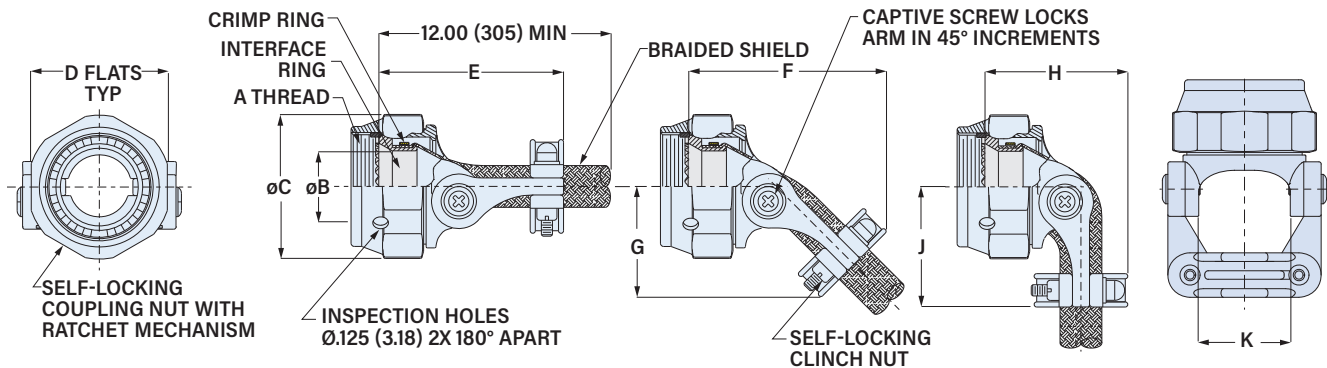

Shell Size	A Thread	øB Min in	mm	øC Max in	mm	D Flats in	mm	E Max in	mm	F Max in	mm	G Max in	mm	H Max in	mm	J Max in	mm	K Ref. in	mm
9 (A)	M12X1.0-6H	.264	6.7	.812	20.6	.750	19.1	1.50	38.1	1.43	36.3	.76	19.3	.95	24.1	.84	21.3	.393	10.0
11 (B)	M15X1.0-6H	.390	9.9	.938	23.8	.875	22.2	1.54	39.1	1.49	37.8	.82	20.8	.99	25.1	.90	22.9	.455	11.6
13 (C)	M18X1.0-6H	.504	12.8	1.125	28.6	1.000	25.4	1.62	41.1	1.64	41.7	.92	23.4	1.14	29.0	1.00	25.4	.598	15.2
15 (D)	M22X1.0-6H	.630	16.0	1.250	31.8	1.125	28.6	1.63	41.4	1.73	43.9	.98	24.9	1.24	31.5	1.07	27.2	.710	18.0
17 (E)	M25X1.0-6H	.756	19.2	1.375	34.9	1.250	31.8	1.73	43.9	1.86	47.2	1.08	27.4	1.36	34.5	1.13	28.7	.839	21.3
19 (F)	M28X1.0-6H	.843	21.4	1.500	38.1	1.375	34.9	1.73	43.9	1.93	49.0	1.12	28.4	1.46	37.1	1.20	30.5	.934	23.7
21 (G)	M31X1.0-6H	.969	24.6	1.625	41.3	1.500	38.1	1.88	47.8	2.08	52.8	1.21	30.7	1.55	39.4	1.26	32.0	1.068	27.1
23 (H)	M34X1.0-6H	1.091	27.7	1.750	44.5	1.625	41.3	1.91	48.5	2.15	54.6	1.27	32.3	1.63	41.4	1.33	33.8	1.197	30.4
25 (J)	M37X1.0-6H	1.217	30.9	1.875	47.6	1.750	44.5	1.94	49.3	2.23	56.6	1.33	33.8	1.70	43.2	1.40	35.6	1.323	33.6

Swing-Arm® Clamps

for MIL-DTL-38999 Series III and IV Connectors

870H002 Swing-Arm Saddle Clamp, Braid Sock, Composite

CLAMP DIMENSIONS

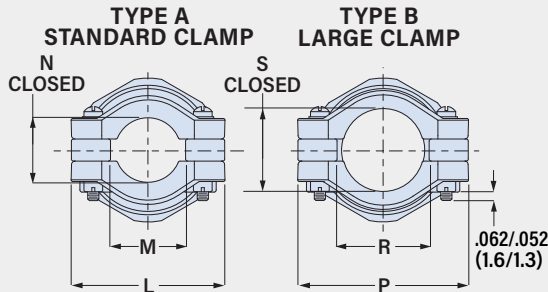

Standard Clamp						Large Clamp					
Shell Size	L Max in	L Max mm	M Min in	M Min mm	N Ref. in mm	Shell Size	P Max in	P Max mm	R Min in	R Min mm	S Ref. in mm
9 (A)	.98	24.9	.22	5.6	.265 6.7	9 (A)	.98	24.9	.33	8.4	.356 9.0
11 (B)	1.05	26.7	.27	6.9	.310 7.9	11 (B)	1.20	30.5	.45	11.4	.422 10.7
13 (C)	1.20	30.5	.35	8.9	.422 10.7	13 (C)	1.45	36.8	.62	15.7	.637 16.2
15 (D)	1.30	33.0	.47	11.9	.538 13.7	15 (D)	1.54	39.1	.68	17.3	.707 18.0
17 (E)	1.44	36.6	.55	14.0	.590 15.0	17 (E)	1.60	40.6	.80	20.3	.759 19.3
19 (F)	1.56	39.6	.62	15.7	.660 16.8	19 (F)	1.73	43.9	.90	22.9	.841 21.4
21 (G)	1.69	42.9	.70	17.8	.744 18.9	21 (G)	1.95	49.5	1.05	26.7	.996 25.3
23 (H)	1.77	45.0	.78	19.8	.826 21.0	23 (H)	2.08	52.8	1.18	30.0	1.060 26.9
25 (J)	1.89	48.0	.85	21.6	.896 22.8	25 (J)	2.32	58.9	1.30	33.0	1.124 28.5

MATERIAL/FINISH

- Coupling nut, body, arms, saddles: polyetherimide (PEI)/unplated
- Screws, washers, inserts: stainless steel/passivated
- Anti-decoupling spring: thermoplastic
- interface Ring: brass or aluminum
- Crimp ring: copper alloy/tin
- Splice ring (optional): thermoplastic
- Clinch Nuts: stainless steel/silver
- Band (optional): stainless steel/passivated
- Braid:
 - Code N: 34 AWG nickel-coated copper
 - Code T: 34 AWG tin-coated copper,
 - Code A: *AmberStrand*® ultralightweight nickel-coated polymer
 - Code L: *ArmorLite*® lightweight microfilament nickel-coated 316L stainless steel

INTERFACE RING AND BRAID

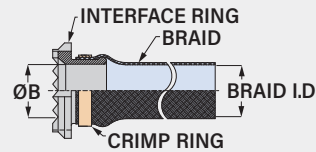

Shell Size	Ø B Min in	Ø B Min mm	Braid I.D. in	Braid I.D. mm
9 (A)	.264	6.7	.375	9.5
11 (B)	.390	9.9	.375	9.5
13 (C)	.504	12.8	.500	12.7
15 (D)	.630	16.0	.500	12.7
17 (E)	.756	19.2	.781	19.8
19 (F)	.843	21.4	.781	19.8
21 (G)	.969	24.6	1.000	25.4
23 (H)	1.091	27.7	1.000	25.4
25 (J)	1.217	30.9	1.250	31.8

FIGURE 1 NF AND BN SELECTIVE FINISH

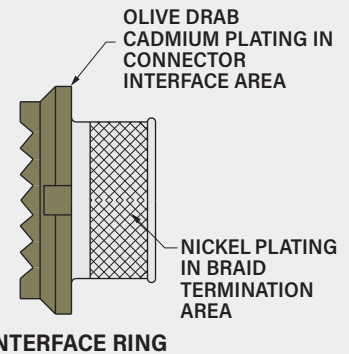

SPLICE RING AND PRE-COILED BAND (K AND J OPTIONS)

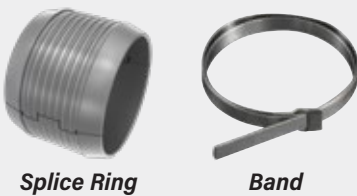

Splice Ring Band

Optional splice ring provides a reliable, low resistance method of splicing Swing-Arm braid to wire bundle braid. Snap splice ring over wire bundle, then overlap braid sock, pigtails and cable braid. Install band around splice ring and braid using Band-Master ATS banding tool.

Slim Standard Band is 50% lighter weight than standard band with no reduction in strength.

Shell Size	Band Part Number		Splice Ring Part Number	ØA		ØB	
	Standard	Slim Standard		±.03 (0.8) in	±.03 (0.8) mm	±.03 (0.8) in	±.03 (0.8) mm
9 (A)	601-006	601-571	687-207XB04	.25	6.4	.40	10.2
11 (B)	601-006	601-571	687-207XB06	.38	9.7	.53	13.5
13 (C)	601-006	601-571	687-207XB08	.50	12.7	.65	16.5
15 (D)	601-006	601-571	687-207XB10	.63	16.0	.78	19.8
17 (E)	601-006	601-571	687-207XB12	.75	19.1	.90	22.9
19 (F)	601-041	601-573	687-207XB14	.88	22.4	1.03	26.2
21 (G)	601-041	601-573	687-207XB16	1.00	25.4	1.15	29.2
23 (H)	601-041	601-573	687-207XB18	1.13	28.7	1.28	32.5
25 (J)	601-041	601-573	687-207XB20	1.25	31.8	1.40	35.6

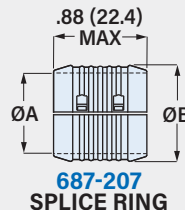

Banding Tool for Standard Band 601-100



Banding Tool for Slim Standard Band 601-109