

Miscellaneous Accessories

Jam Nuts, Splice Rings, Dummy Contacts, Grommet Nuts, Bushings

687-915, 809-094 Jam Nuts

687-915 METRIC JAM NUTS FOR MIL-DTL-38999 SERIES III AND IV RECEPTACLES

Available in aluminum, composite and stainless steel in a variety of finishes, these jam nuts have six drilled safety wire holes.

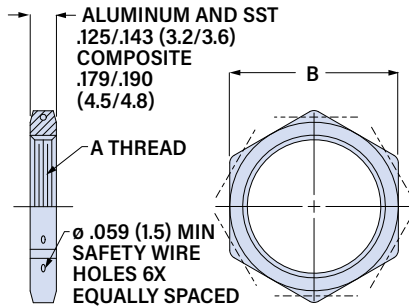

MIL-DTL-38999 SERIES III AND IV

Shell Size Series III	Shell Size Series IV	Part No. * = Material/Finish Code (Table 1)	A Thread Isometric	B Hex Max in	B Hex Max mm
9	—	687-915*1	M17X1-6H	.945	24.0
11	—	687-915*2	M20X1-6H	1.063	27.0
13	11	687-915*3	M25X1-6H	1.260	32.0
15	13	687-915*4	M28X1-6H	1.417	36.0
—	15	687-915*5	M31X1-6H	1.614	41.0
17	—	687-915*6	M32X1-6H	1.457	37.0
—	17	687-915*7	M34X1-6H	1.614	41.0
19	—	687-915*8	M35X1-6H	1.614	41.0
21	19	687-915*9	M38X1-6H	1.811	46.0
23	21	687-915*10	M41X1-6H	1.969	50.0
25	23	687-915*11	M44X1-6H	2.017	51.2
—	25	687-915*12	M47X1-6H	2.165	55.0

TABLE 1 MATL/ FINISH

Aluminum	
ME	Electroless Nickel (Class F, G, R)
G	Hardcoat Anodize (Class C)
MT	Nickel-PTFE (Class T)
NF	Olive Drab Cadmium (Class W)
ZR	Black Zinc-Nickel (Class Z)
Stainless Steel	
Z1	Passivate (Class K, H, Y)
ZL	Nickel (Class N, S, L)
Composite	
XW	Olive Drab Cadmium (Class J)
XM	Electroless Nickel (Class M)
XO	Unplated (Class J, M)

809-094 SPANNER NUTS FOR SERIES 80 MIGHTY MOUSE JAM NUT RECEPTACLES

These spanner-type nuts fit Series 80 Mighty Mouse jam nut receptacles.

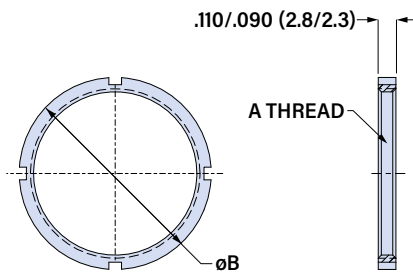

Shell Size					Part Number * = Material/Finish Code (Table 1)	A Thread	øB ± .010 (0.3) in mm
800	801	804 Fr.-Mt.	804 Rr.-Mt.	805			
5					809-094*1	.3125-28 UN-2B	.43 10.9
6	5				809-094*2	.3750-28 UN-2B	.50 12.7
7	6				809-094*3	.4375-28 UNEF-2B	.56 14.2
			5		809-094*3-3	.4375-32 UN-2B	.56 14.2
8		5	6		809-094*4	.5000-32 UN-2B	.62 15.7
				8	809-094*5	.5625-28 UN-2B	.68 17.3
9	7,8	6			809-094*5-5	.5625-32 UN-2B	.68 17.3
	9		7,8		809-094*6	.6250-28 UN-2B	.75 19.1
10					809-094*6-6	.6250-32 UN-2B	.75 19.1
	10	7,8	9	9,10	809-094*7	.6875-28 UN-2B	.81 20.6
12	11	9	10	11	809-094*8	.7500-28 UN-2B	.87 22.1
		10	11	12	809-094*9	.8125-28 UN-2B	.93 23.6
14	13	11	12	13	809-094*10	.8750-28 UN-2B	1.00 25.4
15					809-094*11	.9375-28 UN-2B	1.06 26.9
		12	14	15	809-094*12	1.0000-28 UN-2B	1.12 28.4
	16	14	15		809-094*13	1.0625-20 UN-2B	1.18 30.0
	17	15			809-094*14	1.1250-28 UN-2B	1.25 31.8
				18	809-094*15	1.1875-28 UN-2B	1.31 33.3
	19			19	809-094*16	1.2500-28 UN-2B	1.37 34.8
	21			21	809-094*18	1.3750-28 UN-2B	1.50 38.1
				23	809-094*20	1.5000-28 UN-2B	1.62 41.1

TABLE 1 MATL/ FINISH

Aluminum	
M	Electroless Nickel
MT	Nickel-PTFE
NF	Olive Drab Cadmium
ZR	Black Zinc-Nickel
TZ	Tin-Zinc
Stainless Steel	
Z1	Passivate

TIGHTENING TOOL



Series	Tool Part Number
800, 801	600-146
804	600-147
805	600-154