

Series 44 Banding Backshells

for MIL-DTL-38999 Series I and II Connectors

440F*143 Banding Backshell, Composite, Shrink Boot, Ultra Low Profile 90°



Self-Locking

Solid

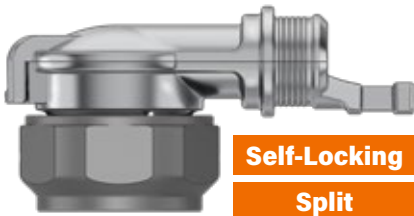

Self-Locking

Split

Adapter Code **F**

This accessory fits these connectors:
MIL-DTL-38999 Series I and Series II

BAND

Optional SST band strap provides fast, cost-effective and highly reliable termination of braided metallic shielding.



Band P/N	Length
601-060	8.13 (206)

SHRINK BOOT

Optional heatshrink boot provides cable strain relief and environmental protection. Type 1 high-performance semi-rigid elastomer resists fuels and oils. Operating temperature range -75 to +150 °C.



FIGURE 1: SLOTS

Optional pigtail shield termination slots are located on banding platform. Profile E split version has one slot. Profile W solid version has two slots.

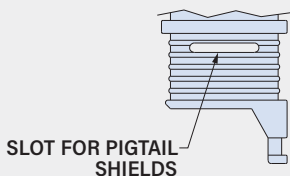

Ultra low-profile 90°. Composite. Self-locking. Micro band. Elliptical entry. Qwik-Ty®. 440F*143 banding backshell fits MIL-DTL-38999 Series I and II connectors. Lightweight, corrosion-free composite material meets AS85049 requirements. Split version has lid for wiring access. Anti-decoupling mechanism provides audible detented coupling and prevents backoff under high vibration. Terminate cable braid shield to backshell with optional micro band strap. Optional shrink boot adds strain relief. Glass-reinforced thermoplastic.

PART NUMBER

PART NUMBER		44FW143	XM	18	D	B	T	S		
Base P/N	Base Part No.	440FE143	E	90° Split						
		440FW143	W	90° Solid						
Finish	XM	Electroless Nickel								
	XMT	Nickel-PTFE								
	XW	Olive Drab Cadmium								
	XTZ	Tin-Zinc								
<i>Coupling nut is unplated, black color.</i>										
Shell Size	Shell Size									
	38999 Series I	9	11	13	15	17	19	21	23	25
	38999 Series II	8	10	12	14	16	18	20	22	24
	Size Code	08	10	12	14	16	18	20	22	24
Drain Holes	<i>Omit if not required</i>									
	D	Drain Holes								
Band	<i>Omit if not required</i>									
	B	Micro Band Included (supplied flat/uncoiled)								
Shrink Boot	<i>Omit if not required</i>									
	T	Shrink Boot Included								
Slot	<i>Omit if not required. See Figure 1.</i>									
	S	Pigtail Termination Slots								

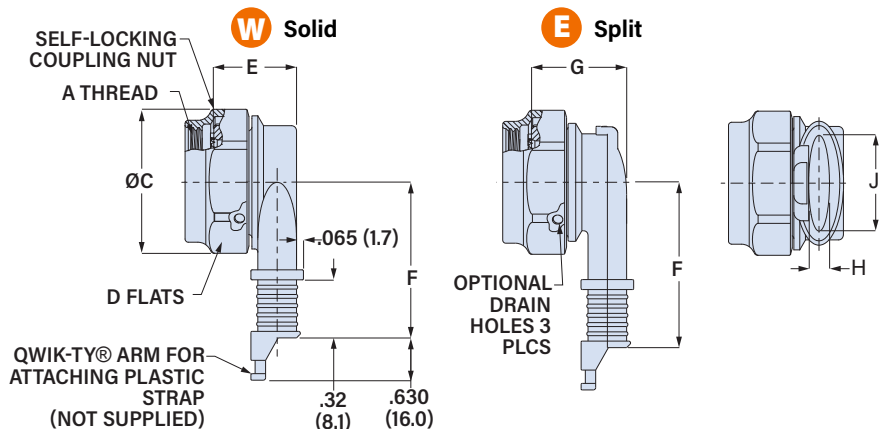

Shell Size	Profile	A Thread UNF-2B	øC Max in mm	Hex Flats in mm	E Max in mm	F ±.03(0.8) in mm	G Max in mm	H ±.06(1.5) in mm	J ±.09(2.3) in mm							
8/9	E, W	0.4375-28	.86	21.8	.750	19.1	.63	16.0	10.42	26.5	.81	20.6	.160	4.1	.304	7.7
10/11	E, W	0.5625-24	.98	24.9	.875	22.2	.66	16.8	1.107	28.1	.81	20.6	.174	4.4	.432	11.0
12/13	E, W	0.6875-24	1.16	29.5	1.000	25.4	.72	18.3	1.174	29.8	.82	20.8	.195	5.0	.546	13.9
14/15	E, W	0.8125-20	1.28	32.5	1.125	28.6	.83	21.1	1.241	31.5	.88	22.4	.315	8.0	.670	17.0
16/17	E, W	0.9375-20	1.41	35.8	1.250	31.8	.91	23.1	1.305	33.1	.93	23.6	.385	9.8	.796	20.2
18/19	E, W	1.0625-18	1.52	38.6	1.375	34.9	.93	23.6	1.371	34.8	.99	25.1	.445	11.3	.902	22.9
20/21	E, W	1.1875-18	1.64	41.7	1.500	38.1	1.04	26.4	1.438	36.5	1.06	26.9	.525	13.3	1.027	26.1
22/23	E, W	1.3125-18	1.77	45.0	1.625	41.3	1.12	28.4	1.505	38.2	1.13	28.7	.595	15.1	1.152	29.3
24/25	E	1.4375-18	1.89	48.0	1.750	44.5	N/A	N/A	1.850	47.0	1.05	26.7	.450	11.4	1.460	37.1
24/25	W	1.4375-18 UNF	1.89	48.0	1.75	44.5	1.18	30.0	1.572	39.9	N/A	N/A	.655	16.6	1.276	32.4