

Series 42 LFMC Conduit Adapters

for MIL-DTL-38999 Series I and II Connectors

420F*001 Adapter for LFMC Liquid-tight Flexible Metal Conduit



Adapter Code F

This accessory fits these connectors:
MIL-DTL-38999 Series I and Series II

PROFILE SELECTION GUIDE

S Straight

A 90° **B** 45°

J 90° **H** 45°

Watertight. Grounded. Spin coupling. 420F*001 adapter fits MIL-DTL-38999 Series I and II connectors. Spin coupling, environmental. Compatible with LFMC liquid-tight flexible metal conduit conforming to UL 360. Install grounding ferrule onto conduit, then tighten nut until ferrule is compressed onto metal core and jacket. Aluminum or stainless steel. Ferrule is zinc-plated steel (trade size 1 or smaller) or aluminum (1¼ or larger). Neoprene O-ring.

PART NUMBER

420FS001 M 18 03 -3

Base P/N	Base Part No.	Profile								
	420FS001	S Straight								
	420FA001	A 90°								
	420FB001	B 45°								
	420FH001	H 45° Cut/Weld								
	420FJ001	J 90° Cut/Weld								
Material/Finish	M	Alum/ Electroless Nickel								
	MT	Alum/ Nickel-PTFE								
	NF	Alum/ Olive Drab Cadmium								
	ZR	Alum/ Black Zinc-Nickel								
	TZ	Alum/ Tin-Zinc								
	ZI	SST/Passivate (Profiles H, J, S only)								
Shell Size	Shell Size									
	38999 Series I	9	11	13	15	17	19	21	23	25
	38999 Series II	8	10	12	14	16	18	20	22	24
	Size Code	08	10	12	14	16	18	20	22	24
Conduit Size	Size Code	Conduit Trade Size	Conduit Diameter (ref.)							
			Inside		Outside					
			in	mm	in	mm				
	01	⅜	.484/.504	12.3/12.8	.690/.710	17.5/18.0				
	02	½	.622/.642	15.8/16.3	.820/.840	20.8/21.3				
	03	¾	.820/.840	20.8/21.3	1.030/1.050	26.2/26.7				
	04	1	1.040/1.066	26.4/27.1	1.290/1.315	32.8/33.4				
	05	1 ¼	1.380/1.410	35.1/35.8	1.630/1.660	41.4/42.2				
06	1 ½	1.575/1.600	40.0/40.6	1.875/1.900	47.6/48.3					
07	2	2.020/2.045	51.3/51.9	2.350/2.375	59.7/60.3					
Length	-3	1.5 inches		<i>Applies to Profile S only. Length in ½ inch increments.</i>						
	-4	2.0 inches								
	-6	3.0 inches								

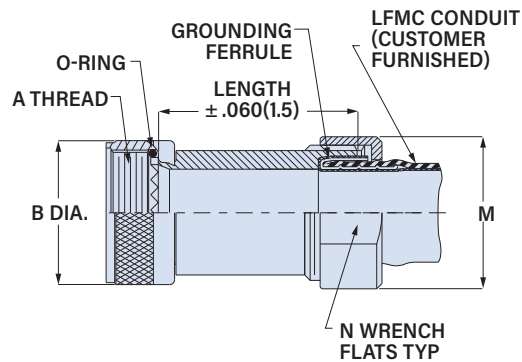

Shell Size	A Thread UNEF-2B	øB Max	
		In	mm
8/9	0.4375-28	.650	16.5
10/11	0.5625-24	.770	19.6
12/13	0.6875-24	.890	22.6
14/15	0.8125-20	1.020	25.9
16/17	0.9375-20	1.150	29.2
18/19	1.0625-18	1.230	31.2
20/21	1.1875-18	1.360	34.5
22/23	1.3125-18	1.480	37.6
24/25	1.4375-18	1.730	43.9

Conduit Size Code	Conduit Trade Size	M Max		N Max	
		in	mm	in	mm
01	⅜	1.155	29.3	1.000	25.4
02	½	1.282	32.6	1.125	28.6
03	¾	1.531	38.9	1.375	34.9
04	1	1.781	45.2	1.625	41.3
05	1 ¼	2.218	56.3	2.062	52.4
06	1 ½	2.468	62.7	2.312	58.7
07	2	3.031	77.0	2.875	73.0

Series 42 LFMC Conduit Adapters

for MIL-DTL-38999 Series I and II Connectors

420F*001 Adapter for LFMC Liquid-tight Flexible Metal Conduit

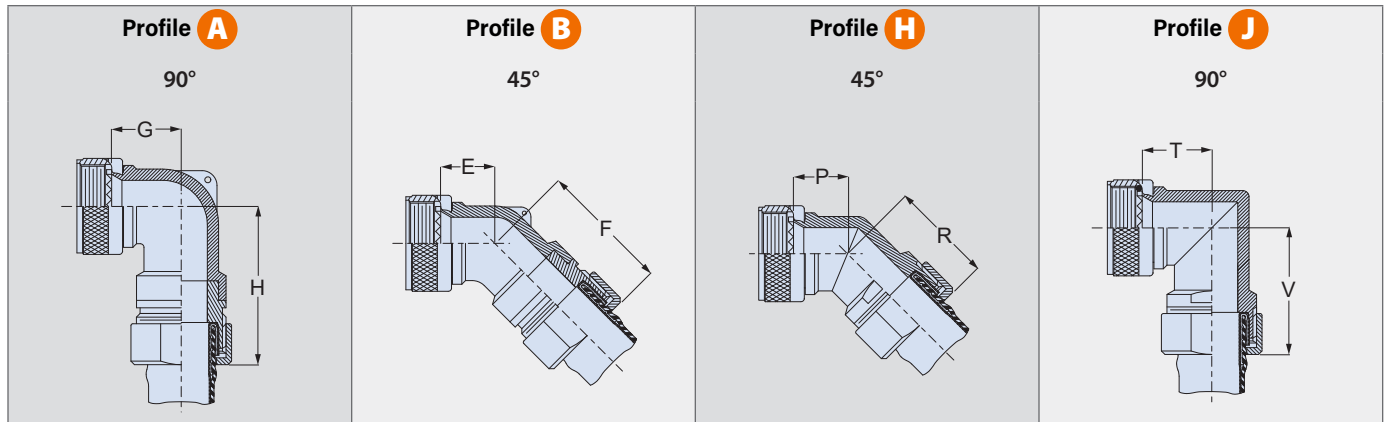

Shell Size	E Max		F Max		G Max		H Max		P Max		R Max		T Max		V Max	
	in	mm	in	mm	in	mm	in	mm	in	mm	in	mm	in	mm	in	mm
8/9	.457	11.6	1.810	46.0	.500	12.7	1.820	46.2	.726	18.4	1.406	35.7	.858	21.8	1.538	39.1
10/11	.520	13.2	1.870	47.5	.595	15.1	1.940	49.3	.750	19.1	1.430	36.3	.917	23.3	1.597	40.6
12/13	.582	14.8	1.930	49.0	.610	15.5	1.960	49.8	.776	19.7	1.456	37.0	.979	24.9	1.659	42.1
14/15	.645	16.4	2.020	51.3	.700	17.8	2.030	51.6	.796	20.2	1.479	37.6	1.036	26.3	1.716	43.6
16/17	.738	18.7	2.130	54.1	.885	22.5	2.120	53.8	.825	21.0	1.505	38.2	1.099	27.9	1.779	45.2
18/19	.926	23.5	2.320	58.9	.975	24.8	2.290	58.2	.845	21.5	1.525	38.7	1.147	29.1	1.826	46.4
20/21	.926	23.5	2.320	58.9	.975	24.8	2.290	58.2	.873	22.2	1.553	39.4	1.215	30.9	1.895	48.1
22/23	1.020	25.9	2.470	62.7	1.125	28.6	2.400	61.0	.899	22.8	1.579	40.1	1.277	32.4	1.957	49.7
24/25	1.020	25.9	2.470	62.7	1.125	28.6	2.400	61.0	.925	23.5	1.605	40.8	1.340	34.0	2.020	51.3