

Series 37 Environmental Backshells

for AS50151 Crimp, M26482 Series II, M83723 Series III, AS95234

370A*001 Backshell, Environmental, Spin Coupling

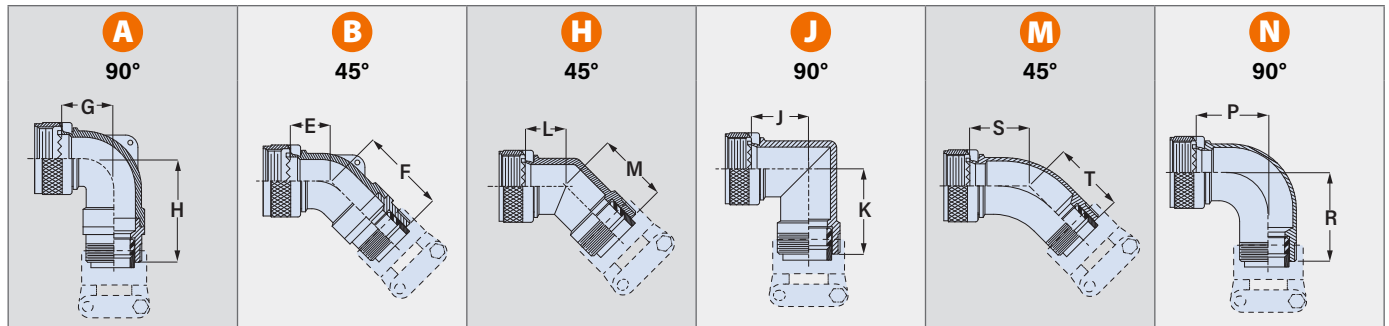

Shell Size	E Max		F Max		G Max		H Max		J Max		K Max		L Max		M Max		P Max		R Max		S Max		T Max	
	in	mm	in	mm	in	mm	in	mm	in	mm	in	mm	in	mm	in	mm	in	mm	in	mm	in	mm	in	mm
08	.457	11.6	1.622	41.2	.500	12.7	1.632	41.5	.834	21.2	1.144	29.1	.726	18.5	1.036	26.3	1.125	28.6	1.445	36.7	.817	20.8	1.127	28.6
10	.520	13.2	1.682	42.7	.595	15.1	1.752	44.5	.898	22.8	1.209	30.7	.753	19.1	1.062	27.0	1.250	31.8	1.570	39.9	.861	21.9	1.181	30.0
12	.582	14.8	1.742	44.2	.610	15.5	1.772	45.0	.956	24.3	1.266	32.1	.777	19.7	1.087	27.6	1.375	34.9	1.695	43.1	.911	23.1	1.231	31.3
14	.645	16.4	2.062	52.4	.700	17.8	2.072	52.6	1.018	25.9	1.328	33.7	.802	20.4	1.113	28.3	1.500	38.1	1.820	46.2	.965	24.5	1.285	32.6
16	.738	18.7	2.172	55.2	.885	22.5	2.162	54.9	1.081	27.4	1.391	35.3	.828	21.0	1.138	28.9	1.625	41.3	1.945	49.4	1.014	25.8	1.334	33.9
18	.926	23.5	2.362	60.0	.975	24.8	2.332	59.2	1.125	28.6	1.435	36.4	.847	21.5	1.157	29.4	1.750	44.5	2.070	52.6	1.064	27.0	1.384	35.2
20	.926	23.5	2.362	60.0	.975	24.8	2.332	59.2	1.188	30.2	1.498	38.0	.873	22.2	1.183	30.0	1.875	47.6	2.195	55.8	1.118	28.4	1.438	36.5
22	1.020	25.9	2.512	63.8	1.125	28.6	2.442	62.0	1.250	31.8	1.560	39.6	.898	22.8	1.208	30.7	2.000	50.8	2.320	58.9	1.172	29.8	1.492	37.9
24	1.020	25.9	2.512	63.8	1.125	28.6	2.442	62.0	1.312	33.3	1.623	41.2	.942	23.5	1.234	31.4	2.125	54.0	2.445	62.1	1.221	31.0	1.541	39.1
28	1.145	29.1	2.562	65.1	1.225	31.1	2.612	66.3	1.392	35.4	1.702	43.2	.957	24.3	1.267	32.2	2.375	60.3	2.695	68.5	1.325	33.7	1.645	41.8
32	1.207	30.7	2.662	67.6	1.575	40.0	2.862	72.7	1.515	38.5	1.825	46.4	1.008	25.6	1.318	33.5	2.675	67.9	2.995	76.1	1.495	37.8	1.815	46.1
36	1.238	31.4	2.752	69.9	1.775	45.1	2.862	72.7	1.623	41.2	1.932	49.1	1.053	26.7	1.363	34.6	2.785	70.7	3.105	78.9	N/A	N/A	N/A	N/A
40	N/A	N/A	N/A	N/A	N/A	N/A	N/A	N/A	1.895	48.1	2.220	56.4	1.220	31.0	1.480	37.6	2.985	75.8	3.215	81.7	N/A	N/A	N/A	N/A

STRAIN RELIEF DIMENSIONS

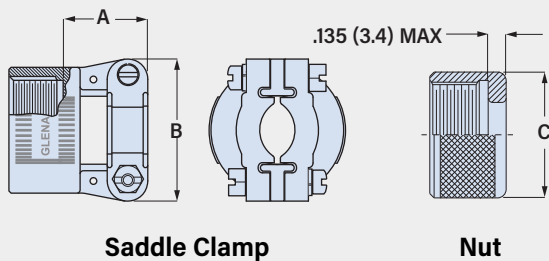

Entry Size	A Max		B Max		øC Max		Cable Range			
	in	mm	in	mm	in	mm	Min*	Max	in	mm
03	.780	19.8	.957	24.3	.630	16.0	.125	3.2	.250	6.4
04	.780	19.8	.957	24.3	.755	19.2	.125	3.2	.312	7.9
06	.780	19.8	1.145	29.1	.942	23.9	.250	6.4	.437	11.1
08	.780	19.8	1.332	33.8	1.067	27.1	.312	7.9	.562	14.3
10	.780	19.8	1.332	33.8	1.192	30.3	.350	8.9	.625	15.9
12	.811	20.6	1.551	39.4	1.380	35.1	.500	12.7	.750	19.1
16	.905	23.0	1.770	45.0	1.535	39.0	.625	15.9	.937	23.8
20	1.092	27.7	2.113	53.7	1.848	46.9	.875	22.2	1.250	31.8
24	1.124	28.5	2.363	60.0	2.255	57.3	1.000	25.4	1.375	34.9
28	1.399	35.5	2.770	70.4	2.505	63.6	1.250	31.8	1.625	41.3
32	1.399	35.5	3.020	76.7	2.755	70.0	1.437	36.5	1.875	47.6

* Not applicable to Style D Nut.

MAXIMUM ENTRY SIZE

If the selected entry size exceeds the maximum size in this table, the backshell will have a front adapter. This is called a **Style 2** backshell.

Shell Size	Max Entry Size	Shell Size	Max Entry Size
08	03	22	16
10	04	24	16
12	06	28	24
14	08	32	28
16	10	36	28
18	12	40	32
20	12		

Style 2 Straight Backshell

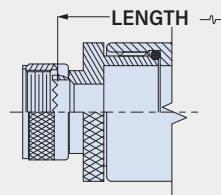

The minimum length code increases from 3 (1 1/2 inches) to 4 (2 inches).

Style 2 45° and 90° Backshells

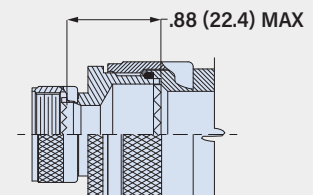

For 45° and 90° backshells, the length increases by .88 inches.