

SPEEDMASTER™

MIGHTY MOUSE, SUPERNINE AND HIPER-D, IFEC CONTACT TECHNOLOGY

OCTOBER 2017

HIGH-SPEED
CONTACT
TECHNOLOGY

SPEEDMASTER™

High-speed IFEC connector system available for Glenair Series 23 SuperNine, Series 824 Mighty Mouse and Series 28 HiPer-D connector.

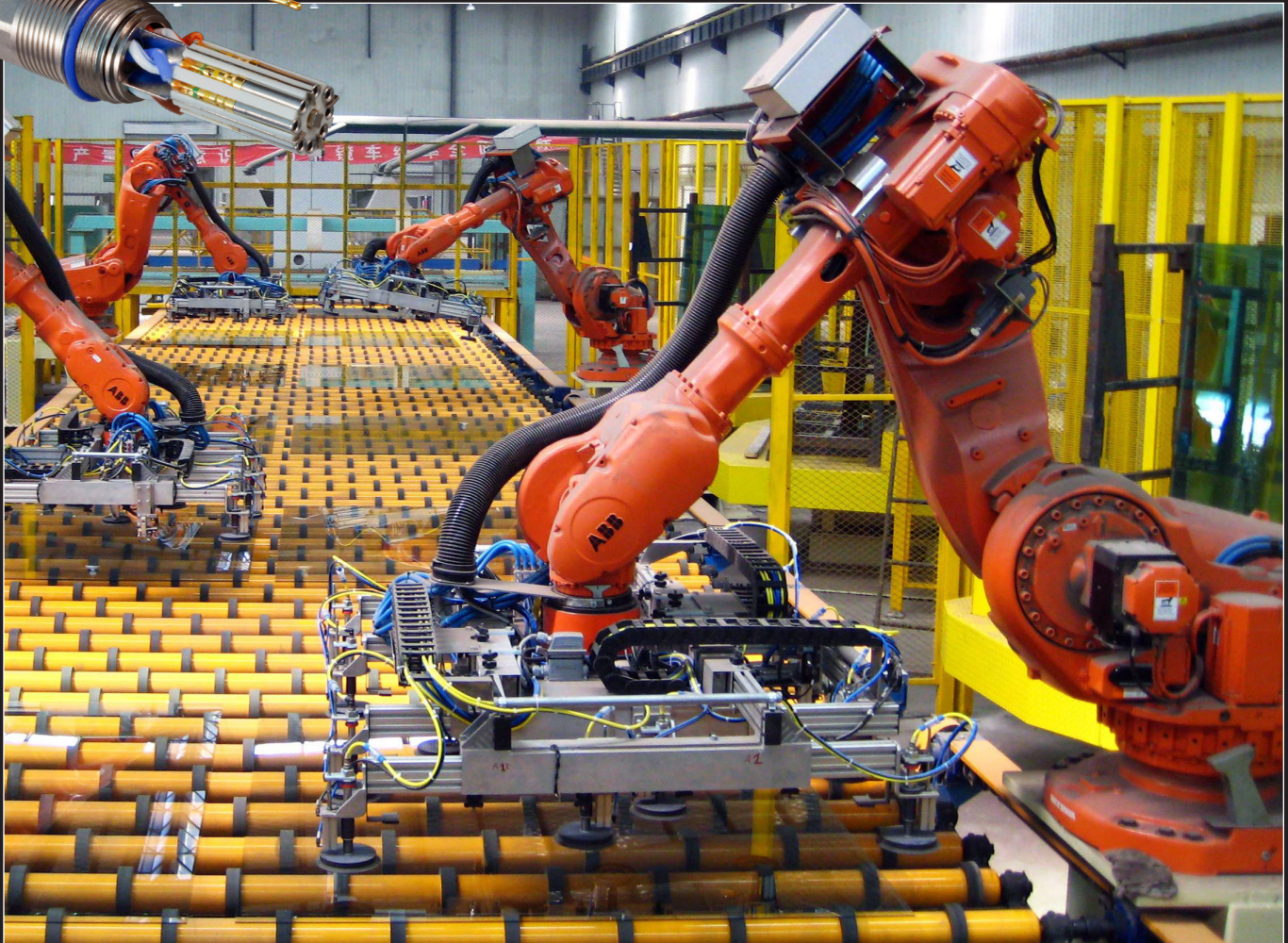

The SpeedMaster contact module, incorporating size 22D contacts, for Cat 6A *High-Speed* networks is available in three industry proven connector styles for general purpose, military and commercial applications. The Series 80 Mighty Mouse 824 locking push/pull connector—an industry standard for size and weight reduction, makes upgrades and repairs easy thanks to its push/pull, quick disconnect design. In addition Glenair also offers the SpeedMaster for our HiPer-D rectangular and Series 23 SuperNine, 38999 type connectors. Our HiPer-D, M24308 connector, features precision-machined aluminum shells and aerospace-grade fluorosilicone grommets that out-perform standard stamped and formed shells. Our growing family of 38999 type SuperNine connectors is constantly improving on this venerable design and the SpeedMaster contact module is part of that growing line-up. Anyway you look at it Glenair has you covered with a *High-Speed* solution that can deliver tomorrows next generation Cat 6A performance today.



Glenair, Inc.
1211 Air Way
Glendale, CA 91201-2497
818-247-6000
sales@glenair.com
www.glenair.com



NEXT-GENERATION
SpeedMaster™
10G high-speed solutions
Product Selection Guide



SpeedMaster Contact Module	
Contact Module Overview	page 4
Contact Ordering Information	
Pre-wired 10G high-speed contacts Modules	page 6
10G High-speed Pin and Socket Modules	page 8
Contact Module 10G Compliance Testing	page 10
Contact Module Assembly Instructions	page 30
Installation Instructions for:	
Mighty Mouse (AI85087)	page 33
HiPer-D (AI85089)	page 34
SuperNine (AI85086)	page 35



Mighty Mouse	
Series 824 Product Specifications	page 10
Series 824 Connectors	page 12
824-009-06 Plug	
824-010-01 In-line Receptacle	
824-010-00 Front Panel Mount, Jam Nut Receptacle	
824-010-07 Rear Panel Mount, Jam Nut Receptacle	

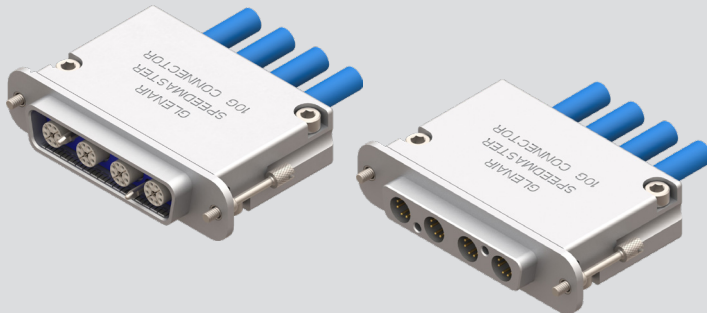

HiPer-D (M24308)	
Series 28 In-Line Connectors	page 14
280-101M Plug	
280-098F Receptacle	
Series 28 Rear Panel Mount Connectors	page 16
280-102M Plug	
280-099F Receptacle	
Series 28 Float Mount Connectors	page 18
280-103M Plug	
280-100F Receptacle	



SuperNine (38999 type)	
Series 23 Specifications	page 20
Series 23 Connectors	page 22
233-219-G6 Plug	
233-219-00 Wall Mount Receptacle	
233-219-07 Jam Nut Receptacle	
377-118 Composite Backshell	
Series 23 Backshells	page 28
377-119 Aluminum Alloy Backshell	



SPEEDMASTER™

NEXT-GENERATION

SpeedMaster™ 10G

High-speed, repairable IFEC connection system

SpeedMaster 10G is purpose-designed to meet the performance requirements and installation and use preferences for the aerospace industry. Optimized for high-speed Cat 6A Ethernet performance, the SpeedMaster 10G system offers industry-leading NEXT, return loss and insertion loss performance due to its highly-engineered isolation and separation architecture. Easy to assemble, terminate, install and repair, the SpeedMaster 10G utilizes size #22D contacts, tools, and cable, and meets the broad range of aerospace industry requirements for vibration, temperature cycling, durability, and safe, reliable performance. Applications include defense, aircraft electronics—military and commercial, inflight entertainment, medical equipments, rail electronics systems, industrial equipment and industrial automation/robotics.

- Utilizes aerospace industry standard #22D contacts, tools and widely available Ethernet flight cable
- Fast, easy termination
- Significant weight reduction compared to Quadrax solutions (reduces cable requirement by ½)
- High-density, repairable solution—ideally suited for today's networked IFEC environments



Mighty Mouse Locking Push/Pull Plug and Receptacle



HiPer-D Rectangular (M24308)



SuperNine Plug and Receptacle



NEXT-GENERATION
SpeedMaster™
10G high-speed contacts
Repairable IFEC Connection System

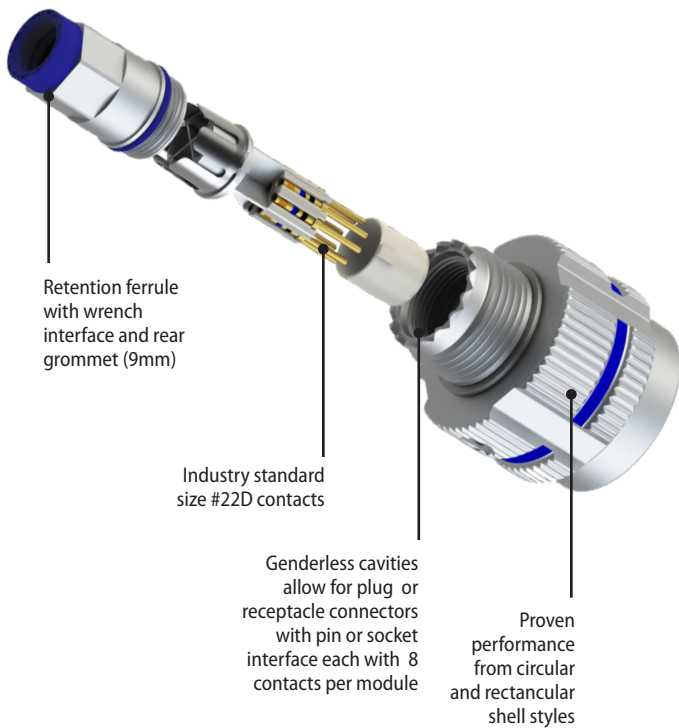

The SpeedMaster Difference

SpeedMaster, the high-speed multi-contact solution for the Mighty Mouse, HiPer-D and SuperNine 38999 type family of connectors. Each SpeedMaster module consists of 4 pairs of pins or sockets incorporating industry standard size 22D contacts to provide 10G performance. Each module is individually shielded within the shell, and retained in place with a threaded ferrule. Additionally, module cavities are genderless allowing pin or socket interface for plugs or receptacles. Glenair offers these SpeedMaster contacts in 3 connector packages, including our small form factor Mighty Mouse Series 824 Locking Push/Pull, HiPer-D (M24308) hi-performance rectangular D-Sub, and our 38999 type “better than QPL” connectors allowing you to adapt and fit your application needs. These features result in a two fold benefit. An easily removable and repairable, shielded high performance contact packaged within robust industry standard connectors, helping to reduce network downtime and providing a connectorized solution to improve the overall network function and performance. Meet the demand for the next generation Cat 6A networks with SpeedMaster, the next generation contact system from Glenair.

SPEEDMASTER 10G NEXT-GENERATION IFEC CONNECTION SYSTEM

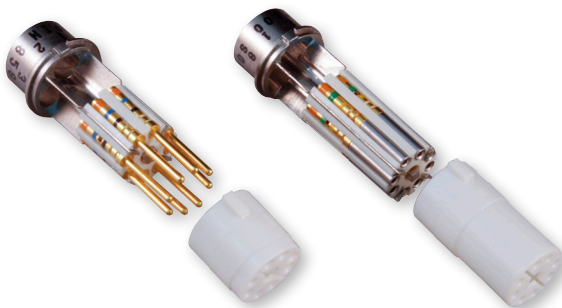

SpeedMaster 10G modular inserts are available for Series 23 SuperNine – 38999, Series 80 Mighty Mouse – Locking Push / Pull and Series 28 HiPer-D – M24308 rectangular D-Sub connectors



The SpeedMaster 10G is optimized for high-speed ethernet performance and incorporates standard M39029 #22D contacts isolated for superior NEXT, return loss and insertion loss performance

8575-0001 SpeedMaster™ Cat 6A contacts, pre-wired for use in MIL-DTL-38999 Series III type connectors

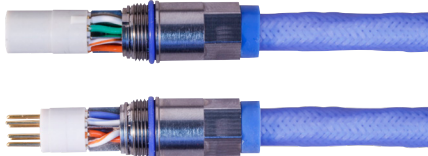

Technical Data Specifications

- Operating temperature: -65°C to +200°C (SpeedMaster) or -40°C to +85°C (RJ45); cable dependent
- Meets EIA/TIA 568C.2-10 and IEC 60603-7-51 Cat 6A 500 MHz
- Characteristic Impedance: 100 ohms
- Insulation resistance: 200 megohms min.
- Durability: 500 mating cycles

SpeedMaster Construction

- Isolator body:** copper alloy/electroless nickel
- Contacts:** copper alloy, gold plated
- Retention ferrule and shield ferrule:** copper alloy/electroless nickel
- Insulator:** rigid plastic/N.A.
- O-rings/grommets:** fluorosilicone blend/N.A.

RJ45 Construction

- Body:** UL 94-V0 polycarbonate
- Grommet:** UL 94-V0 polycarbonate
- Contacts:** copper alloy, 50 microinches selective gold plating
- Shield:** nickel-plated copper alloy

Connector Compatibility

- Glenair 824-009 and -010 Mighty Mouse
- Glenair 280-098 thru -103 HiPer-D
- Glenair 233-219 SuperNine

Contact Positions

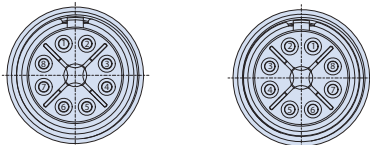

Mating Face of Pin Contacts

Mating Face of Socket Contacts

Notes

- 100% tested for continuity, DWV and IR.
- Not available in pin to pin or socket to socket configurations..

Pre-wired SpeedMaster assemblies are 100% tested and ready for use. For use with Series 23 SuperNine connectors with keyed size #8 cavities, these assemblies are available with three termination options: single-ended SpeedMaster contacts on one end, SpeedMaster contacts on both ends, or SpeedMaster contact on one end and RJ45 plug on the other end.

858-102 is superseded by 8575-0001

Part Number Development					
Sample Part Number	8575-0001	-A	C	-1	-12
Product	8575-0001				
End A Contact Type*	-A = 858-101-X SpeedMaster pin -B = 858-100-X SpeedMaster socket				
End B Contact/Connector*	A = SpeedMaster pin B = SpeedMaster socket C = RJ45 plug N = No connector				
Cable Option	-1 = 963-003-24 -2 = 963-003-26 -4 = 963-037		-5 = 963-033-24 -6 = 963-033-26		
Length	Overall length in inches				

* Not available in pin to pin or socket to socket configurations

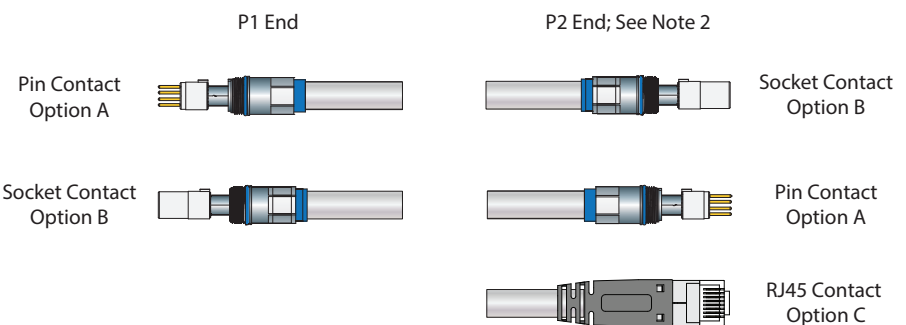
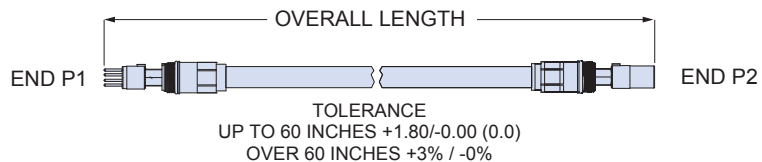

8575-0001 SpeedMaster™ Cat 6A contacts, pre-wired for use in MIL-DTL-38999 Series III type connectors

8575-0001 SPEEDMASTER™ WIRING DIAGRAMS

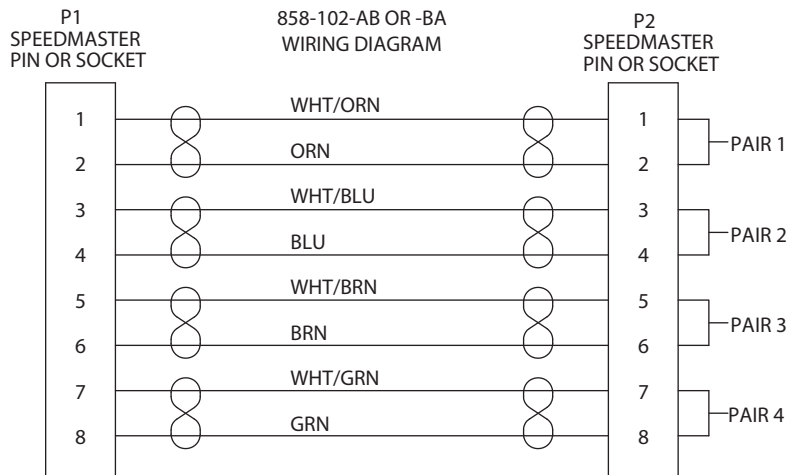

SPEEDMASTER TO SPEEDMASTER IS 1 TO 1.
MUST BE PIN TO SOCKET OR SOCKET TO SOCKET TO PIN
OMIT P2 FOR 858-102-AN OR -BN

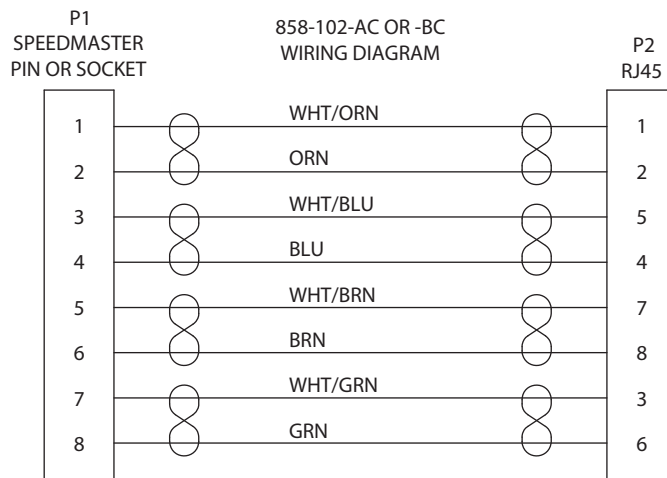

SPEEDMASTER PIN OR SOCKET TO RJ45 PLUG



NEXT-GENERATION SpeedMaster™ 10G high-speed contacts



858-100 and 858-101, 10GBase-T Cat 6A Contacts

858-100 SPEEDMASTER SOCKET MODULE

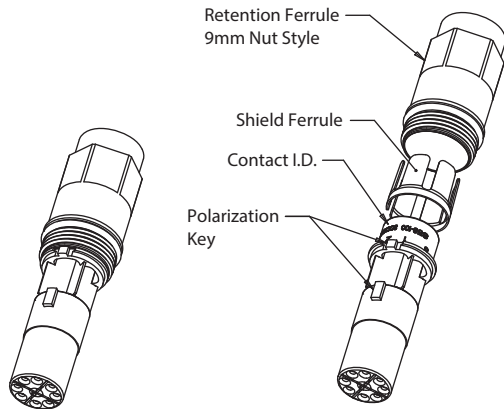

858	-100	-1
Product Code	Basic No	See Cable Size Table

Cable Size	
Cable Size	Cable Ø
1	.280 (7.11)
2	.270 (6.86)
3	.260 (6.60)
4	.250 (6.35)
5	.240 (6.10)
6	.230 (5.84)
7	.220 (5.59)

Speedmaster™ Module Inner Contact Pinout		Pin Out	
		Location	Color
		1	Orng/Wht
		2	Orange
		3	Blu/Wht
		4	Blue
		5	Brwn/Wht
		6	Brown
		7	Grn/White
		8	Green

858-101 SPEEDMASTER PIN MODULE

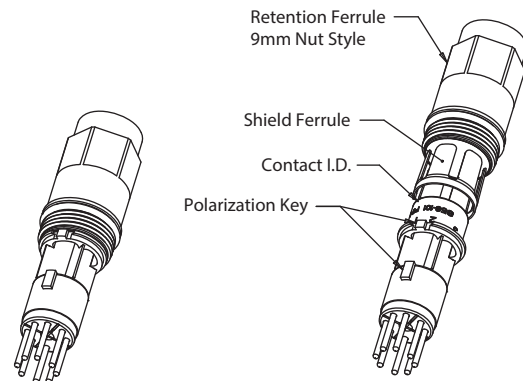

858	-101	-1
Product Code	Basic No	See Cable Size Table

SPEEDMASTER MODULE MATERIAL/FINISH

- IMPORTANT: SpeedMaster high-speed modules can only be installed in Glenair SpeedMaster series connectors.**
- High-speed module is designed to accommodate cable with wire insulation up to Ø.055 inches and cable jackets up to Ø.280 inches. See cables table for suggest list.
- For cables in-between sizes, select smaller size.
- See AI85082 for assembly instructions
- Tools Needed:
 - M39029/57-354 socket contacts:
 - Basic tool M22520/2-01 (Glenair P/N 809-015)
 - Positioner M22520/2-06 (Glenair P/N 859-019)
 - M39029/58-360 pin contacts:
 - Basic tool M22520/2-01 (Glenair P/N 809-015)
 - Positioner M22520/2-09 (Glenair P/N 859-018)
- Material/Finish
 - Isolator body - copper alloy / electroless nickel.
 - Contacts - copper alloy / gold plated
 - Retention ferrule - copper alloy / electroless nickel.
 - Inner shield ferrule: copper alloy / electroless nickel.
 - Insulators - rigid dielectric / N.A.
 - O-rings/grommets - fluorosilicone blend / N.A

Cables*					
Cable P/N	Cable Category	Cable Construction	Wire Gage	Cable Ø	Assembly Instructions
963-003-24	Cat 6A	SF/UTP	24	.280 (7.11)	AI85082
963-003-26	Cat 6A	SF/UTP	26	.220 (5.59)	
963-037	Cat 6A	SF/UTP	24	.260 (6.60)	

*Consult factory for use with other cable



NEXT-GENERATION SpeedMaster™ 10G high-speed contacts 10GBase-T Cat 6A Compliance Testing Contacts

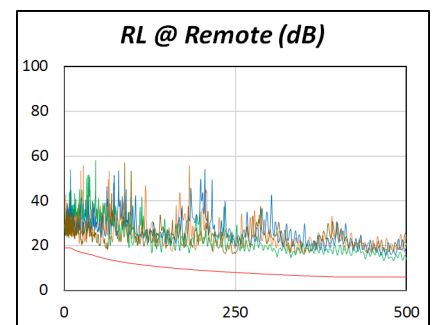
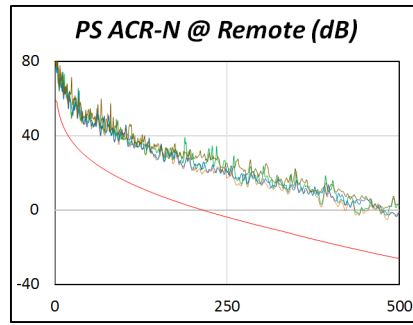
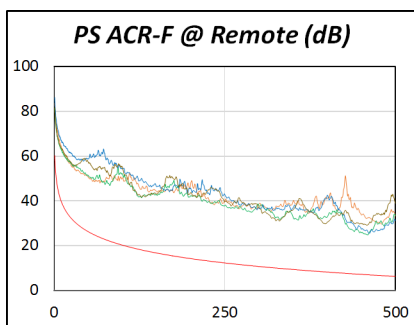
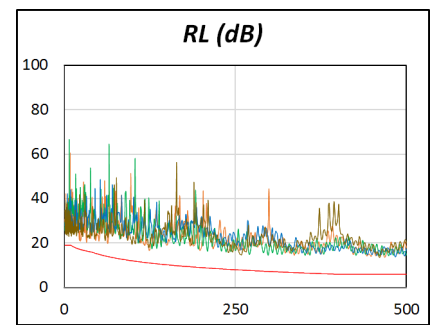
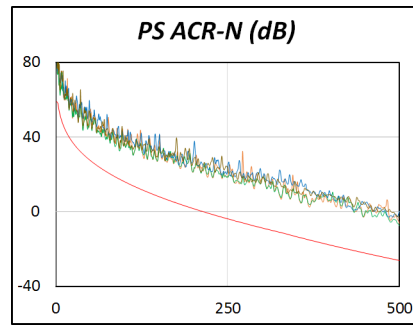
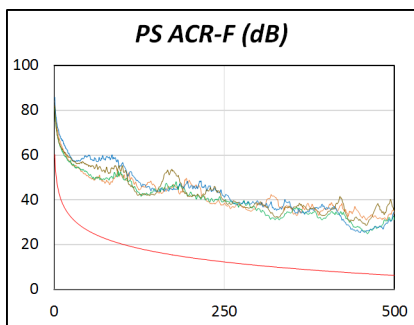
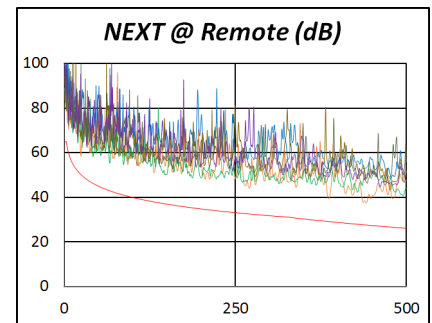
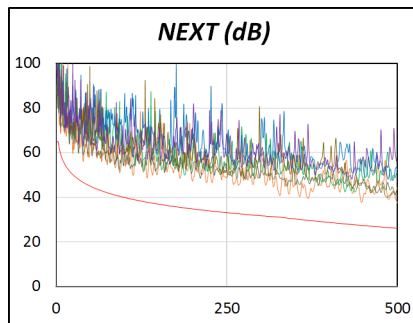
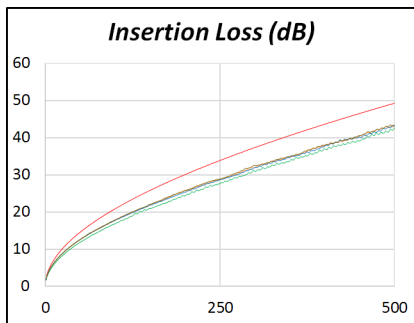
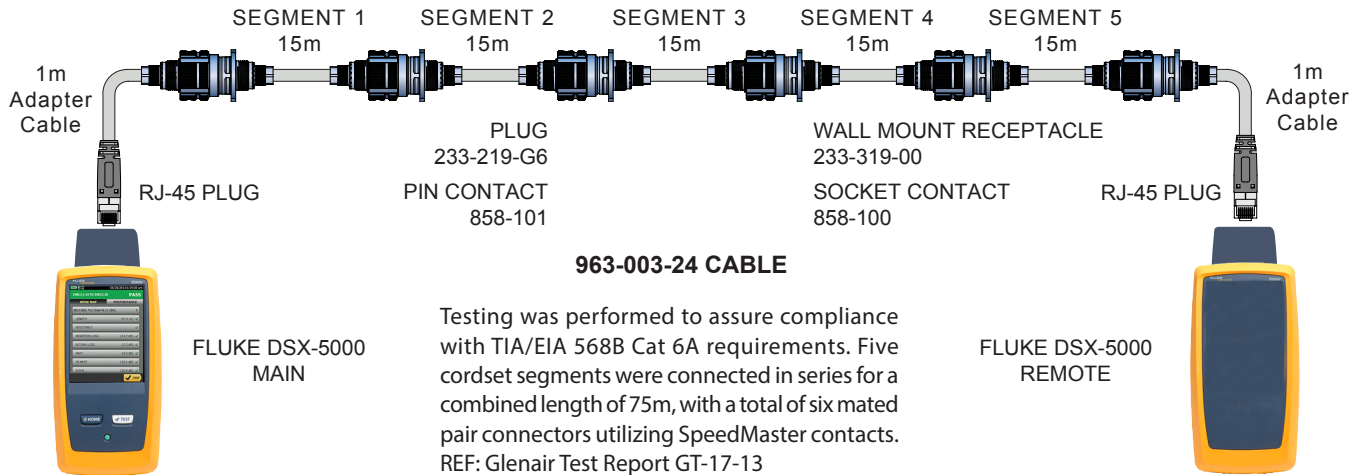



SERIES 80

Mighty Mouse Connectors with SpeedMaster™ 10G high-speed contacts



Series 824 Product Specifications And Summary

Performance Specification, IAW MIL-DTL-32546, TIA-568-C.2, EIA-364, Glenair Mighty Mouse 824, & Glenair SpeedMaster			
Test	Test Requirement	Requirement Met	
	Individual contact modules meet the performance requirements of TIA-568-C.2:		
High-speed Performance*	<ul style="list-style-type: none"> • Return Loss • Insertion Loss • NEXT • PS NEXT 	<ul style="list-style-type: none"> • ACR-F • PS ACR-F • ACR-N 	Meets TIA-568-C.2, section 6.2
Temperature Cycling†	-65°C to +150°C		
Durability‡	No electrical or mechanical defects after 500 cycles of engagement and disengagement	Meets MIL-DTL-32546, paragraph 3.11	
Insulation Resistance at Ambient Temperature*	Unmated connectors shall be tested as specified in EIA-364-21 5000 megaohms min. at 25°C	Meets MIL-DTL-32546, paragraph 3.13.1	
Insulation Resistance at Elevated Temperature*	Unmated connectors shall be tested as specified in EIA-364-21 1000 megaohms min. at 150°C		
Salt Spray‡	Finish	Corrosion Resistance	MIL-DTL-32546, paragraph 3.16 Finish ME: Meets Finishes MT & ZNU: Exceeds
	Electroless Nickel (ME)	48 hrs	
	PTFE/Nickel (MT)	500 hrs	
	Black Zinc-Nickel (ZNU)	500 hrs	
Vibration, Sine	No discontinuity greater than 1 microsecond, no cracking, breaking, or loosening of parts, plug shall not become disengaged from the receptacle. Connectors shall meet electrical requirements after test. 16.91 G's		
Vibration, Random at Ambient Temperature‡	No discontinuity greater than 1 microsecond, no cracking, breaking, or loosening of parts, plug shall not become disengaged from the receptacle. Connectors shall meet electrical requirements after test. 16.91 G's rms		Meets EIA-364-28, Condition V, Letter E
Standard Shock‡	No loosening of parts, cracking, or other deleterious results hindering further part operation after 100 G's in each of 3 mutually perpendicular planes		Meets EIA-364-27, Condition C
Shell-to-Shell Conductivity‡	Finish	Maximum Millivolt Drop	Exceeds MIL-DTL-32546, paragraph 3.23
	PTFE/Nickel (MT)	2.5 mV	
Humidity‡	Testing shall be performed as specified in EIA-364-21, Method IV		Meets MIL-DTL-32546, paragraph 3.25



SERIES 80



Mighty Mouse Connectors with SpeedMaster™ 10G high-speed contacts

Series 824 Product Specifications And Summary

Performance Specification, IAW MIL-DTL-32546, TIA-568-C.2, EIA-364,
Glenair Mighty Mouse 824, & Glenair SpeedMaster

Test	Test Requirement						Requirement Met
Shielding Effectiveness‡	Leakage Attenuation Min (dB)			Leakage Attenuation Min (dB)			Meets MIL-DTL-32546, paragraph 3.27
	Frequency (MHz)	Finish ME	Finishes MT, ZNU	Frequency (MHz)	Finish ME	Finishes MT, ZNU	
	100	90	90	1,500	76	69	
	200	88	88	2,000	70	65	
	300	88	88	3,000	69	61	
	400	87	87	4,000	68	58	
	800	85	85	6,000	66	55	
1,000	85	85	10,000	65	50		
Fluid Immersion	No visible damage from immersion in various fuels and oils. Electrical performance requirements shall still be met.						

* Indicates that test has been performed/data is available

† Thermal cycling has been done from -55°C to +200°C

‡ Qualification by similarity

SERIES 824 MIGHTY MOUSE SPEEDMASTER MATERIAL

- Shell, Barrel, Coupling Nut: Aluminum per ASTM-B211.
- Latch sleeve: BeCu Alloy/electroless nickel
- O-rings: fluorosilicone / N.A.
- Canted coil spring: copper alloy/gold

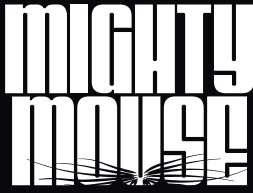

SERIES 80

Mighty Mouse Connectors

with SpeedMaster™ 10G high-speed contacts

Locking Push/Pull Connectors - How To Order



Quick Disconnect

These plugs snap securely into receptacle housings and release with a simple pull.

Full Mating Indicators

Audible, visual and tactile full mate indicators and simple push/pull action allow for quick, easy mating even in low-light situations,

Part Number Development					
Sample Part Number	824-010-01 MT P A -1				
Series and Shell Style	824-009-06 = Plug with Shrink Boot Groove 824-010-01 = In-line Receptacle with Boot Groove 824-010-00 = Front Panel Mount, Jam Nut Receptacle with Boot Groove 824-010-07 = Rear Panel Mount, Jam Nut Receptacle with Boot Groove See shell style table				
Shell Material and Finish	ME = Aluminum alloy / electroless nickel MT = Aluminum alloy / nickel-PTFE, RoHS compliant ZN = Aluminum alloy / olive drab zinc-nickel over electroless nickel ZNU = Aluminum alloy / black zinc nickel over electroless nickel				
Module Type	P = Pin S = Socket A = Less contacts; see note 1				
Alternative Polarization	A, B, C, D, E				
Cable Size	See cable size table; Omit when ordering pre-wired contact modules				

Alternate Positions		
	Plug (Key)	Receptacle (Keyway)
Pos.	A°	B°
A	140	220
B	30	220
C	30	250
D	110	330
E	140	330

Shell Style	
824-009-06 Plug with Shrink Boot Groove	824-010-00 FPM Jam Nut, Receptacle with Shrink Boot Groove
824-010-01 In-Line Receptacle with Shrink Boot Groove	824-010-07 RPM Jam Nut Receptacle with Shrink Boot Groove



SERIES 80

Mighty Mouse Connectors with SpeedMaster™ 10G high-speed contacts



Locking Push/Pull Connectors - Dimensions

PLUG SHELL STYLE 824-009-06

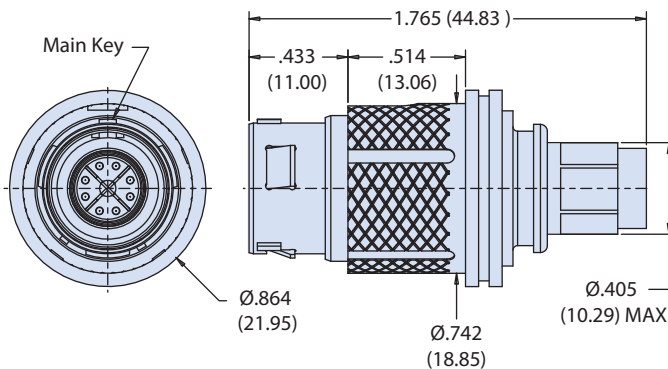

FRONT PANEL MOUNT, JAM NUT REPTACLE SHELL STYLE 824-010-00

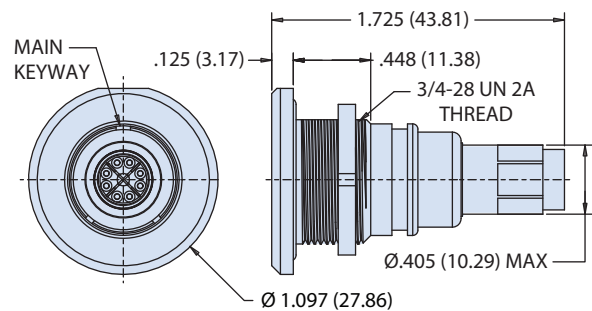

IN-LINE RECEPTACLE SHELL STYLE 824-010-01

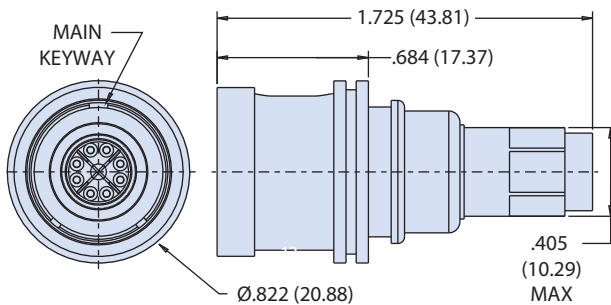

JAM NUT, REAR PANEL MOUNT RECEPTACLE SHELL STYLE 824-010-07

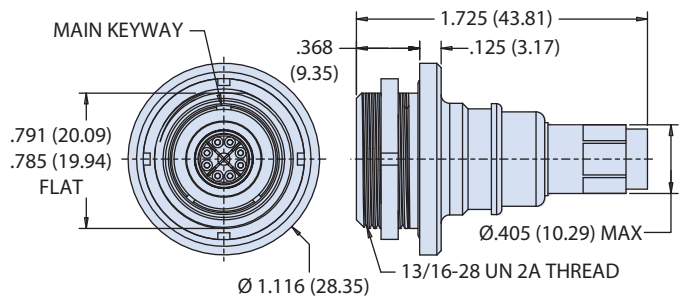

Cable Size Options (See note 5)	
Cable Size	Cable Diameter
1	.280 (7.11)
2	.274 (6.96)
3	.260 (6.60)
4	.250 (6.35)
5	.240 (6.10)
6	.230 (5.84)
7	.220 (5.59)

Cables*					
Cable P/N	Cable Category	Cable Construction	Wire Gage	Cable Dia.	Assembly Instructions
963-003-24	Cat 6A	SF/UTP	24	.280 (7.11)	AI85082
963-003-26	Cat 6A	SF/UTP	26	.220 (5.59)	
963-037	Cat 6A	SF/UTP	24	.260 (6.60)	

*Contact factory to inquire about use with other cables

NOTES

- Spare high-speed modules (858-100 and 858-101) may be ordered separately. Module wrench tool (607-011) supplied with each connector. Select the "less contacts (A)" option when ordering pre-terminated cable to SpeedMaster contacts listed on page 6 and 7. Omit cable size from part number development when selecting the "less contact" option from the module type of the part number development.
- See assembly instruction AI85082 for high-speed module terminations. See assembly instructions AI85087 for module installation.
- See cable size table for available cable size options. For cable in-between sizes select smaller size. Maximum cable diameter is .280
- See page 8 for SpeedMaster module inner contact pinout.
- Material / finish:
 - Shell: see part number development
 - Canted coil spring: copper alloy/gold
 - Latch sleeve: BeCu Alloy/electroless nickel
 - O-rings: fluorosilicone / N.A.
 - Shrink boot: LSZH / N.A.



SERIES 28

HiPer-D M24308 connectors with SpeedMaster™ 10G high-speed contacts



HiPer-D In-Line Cable Connectors - How to Order

Part Number Development						
Sample Part Number	280-101M	4	P	MT	N	-1
Series	280-101M = In-line cable plug 280-098F = In-line cable receptacle					
Cavity Count	2 = 2 Cavities 4 = 4 Cavities					
Module Type	P = Pin S = Socket A = Less contacts; see note 1					
Material and Finish	NF = Aluminum alloy / Cadmium olive drab over electroless nickel MT = Aluminum alloy / nickel-PTFE ME = Aluminum alloy / electroless nickel ZR = Aluminum alloy / zinc nickel black RoHs compliant					
Hardware Options	P, L, K, S, T or N (no hardware)					
Cable Size	See cable size table; omit for preterminated contact modules					

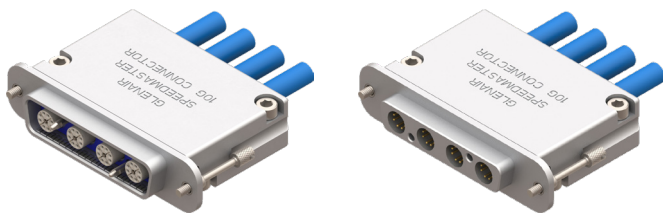

Cables*					
Cable P/N	Cable Category	Cable Construction	Wire Gage	Cable Dia.	Assembly Instructions
963-003-24	Cat 6A	SF/UTP	24	.280 (7.11)	AI85082
963-003-26	Cat 6A	SF/UTP	26	.220 (5.59)	
963-037	Cat 6A	SF/UTP	24	.260 (6.60)	

*Contact factory to inquire about use with other cables

Mating Hardware		
P	L	K
Female Jackpost	Captive Jackscrew, Hex Head, Low Profile	Slot-Head Extended Jackscrew
S	T	
Captive Screwlock, Hex Head, Low Profile	Slot-Head Extended Length, Screwlock	

Cable Size	
Cable Size	Cable Diameter
1	.280 (7.11)
2	.274 (6.96)
3	.260 (6.60)
4	.250 (6.35)
5	.240 (6.10)
6	.230 (5.84)
7	.220 (5.59)

NOTES

- Spare high-speed modules (858-100, 858-101) may be ordered separately. Module wrench tool (607-011) supplied with each connector. Select the "less contacts (A)" option when ordering pre-terminated cable to SpeedMaster contacts listed on page 6 and 7. Omit cable size from part number development when selecting the "less contact" option from the module type of the part number development.
- See Assembly instructions AI 85082 for high-speed module terminations. See assembly instructions AI85089 for module installation.
- See page 8 for SpeedMaster module inner contact pinout
- For cables in-between sizes, select smaller size. Maximum cable diameter is .280 (7.11)
- Material / Finish:
 - Shells: see part number development table
 - Hardware: stainless steel - passivated
 - Grounding spring: BeCu alloy / electroless nickel
 - Seals, o-ring: fluorosilicone blend / N.A.

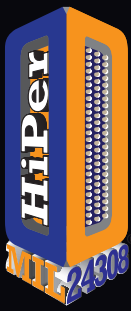

SERIES 28



HiPer-D M24308 connectors with SpeedMaster™ 10G high-speed contacts

HiPer-D In-Line Cable Connectors - How to Order

280-101 HIPER-D IN-LINE CONNECTOR, RECEPTACLE

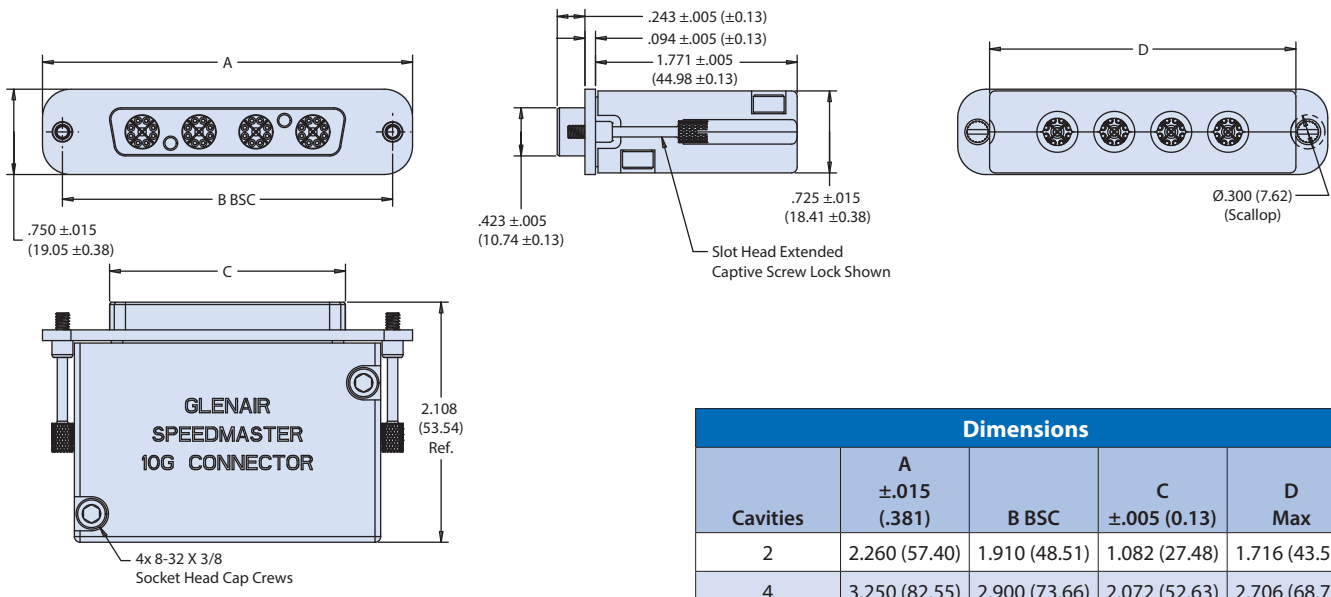

280-098 HIPER-D IN-LINE CONNECTOR, PLUG

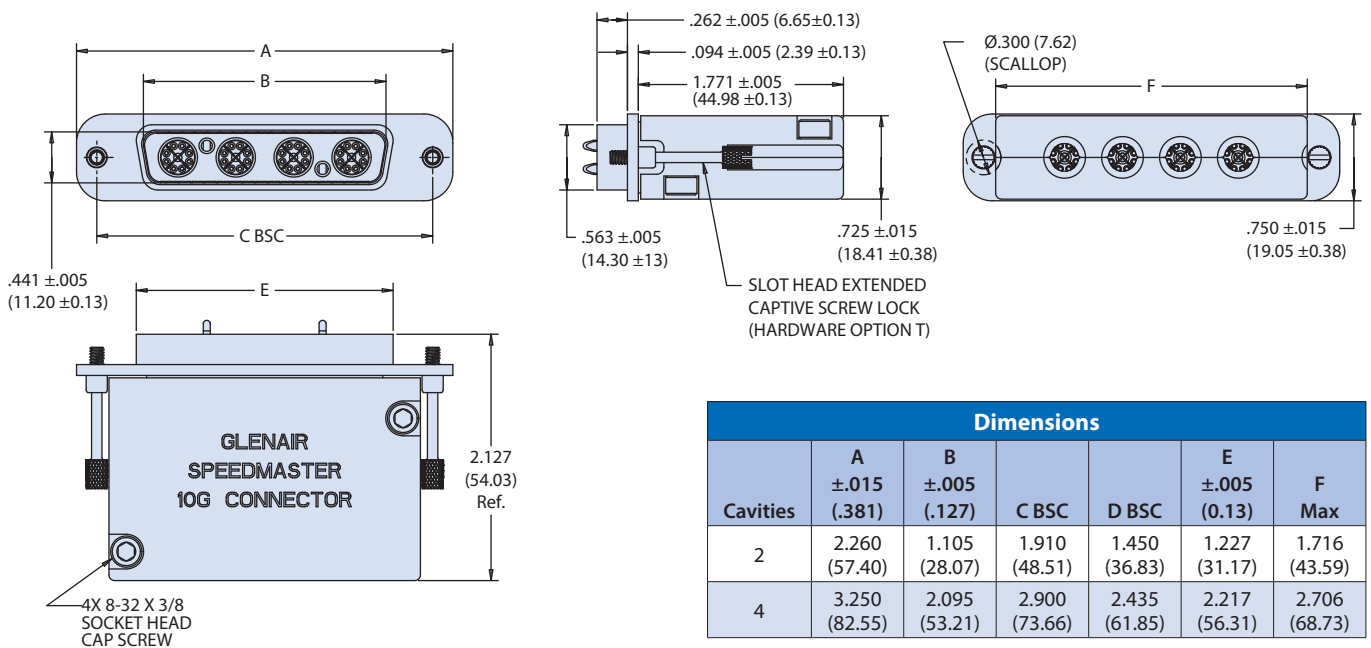

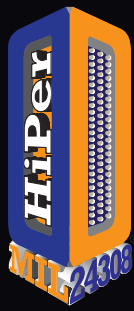

SERIES 28

HiPer-D M24308 connectors with SpeedMaster™ 10G high-speed contacts



HiPer-D Rear Panel Mount Connectors - How to Order

Part Number Development						
Sample Part Number	280-103M	4	P	MT	N	-1
Series	280-102M = rear panel mount plug 280-099F = rear panel mount receptacle					
Cavity Count	2 = 2 Cavities 4 = 4 Cavities					
Module Type	P = Pin S = Socket A = Less contacts; see note 1					
Material and Finish	NF = Aluminum alloy / Cadmium olive drab over electroless nickel MT = Aluminum alloy / nickel-PTFE ME = Aluminum alloy / electroless nickel ZR = Aluminum alloy / zinc nickel black RoHs compliant					
Hardware Options	P = Female jackpost					
Cable Size	See cable size table; omit for preterminated contact modules					

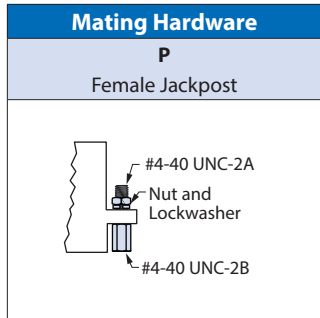
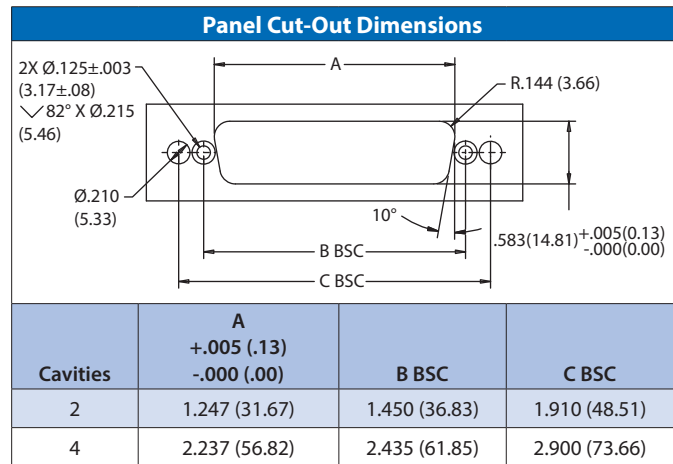
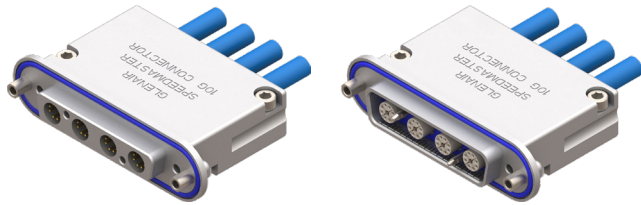

Cable Size

Cable Size	Cable Diameter
1	.280 (7.11)
2	.274 (6.96)
3	.260 (6.60)
4	.250 (6.35)
5	.240 (6.10)
6	.230 (5.84)
7	.220 (5.59)

Cables*

Cable P/N	Cable Category	Cable Construction	Wire Gage	Cable Dia.	Assembly Instructions
963-003-24	Cat 6A	SF/UTP	24	.280 (7.11)	AI85082
963-003-26	Cat 6A	SF/UTP	26	.220 (5.59)	
963-037	Cat 6A	SF/UTP	24	.260 (6.60)	

*Contact factory to inquire about use with other cables

NOTES

1. Spare high-speed modules (858-100, 858-101) may be ordered separately. Module wrench tool (607-011) supplied with each connector. Select the "less contacts (A)" option when ordering pre-terminated cable to SpeedMaster contacts listed on page 6 and 7. Omit cable size from part number development when selecting the "less contact" option from the module type of the part number development.
2. See Assembly instructions AI 85082 for high-speed module terminations. See assembly instructions AI85089 for module installation.
3. See page 8 for SpeedMaster module inner contact pinout
4. For cables in-between sizes, select smaller size. Maximum cable diameter is .280 (7.11)
5. Material / Finish:
 - Shells: part number development table
 - Hardware: stainless steel - passivated
 - Grounding spring: BeCu alloy / electroless nickel
 - Seals, o-ring: fluorosilicone blend / N.A.

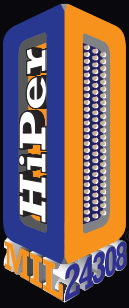

SERIES 28

HiPer-D M24308 connectors with SpeedMaster™ 10G high-speed contacts



HiPer-D Rear Panel Mount Connectors - Dimensions

280-102 HIPER-D REAR PANEL MOUNT CONNECTOR, PLUG

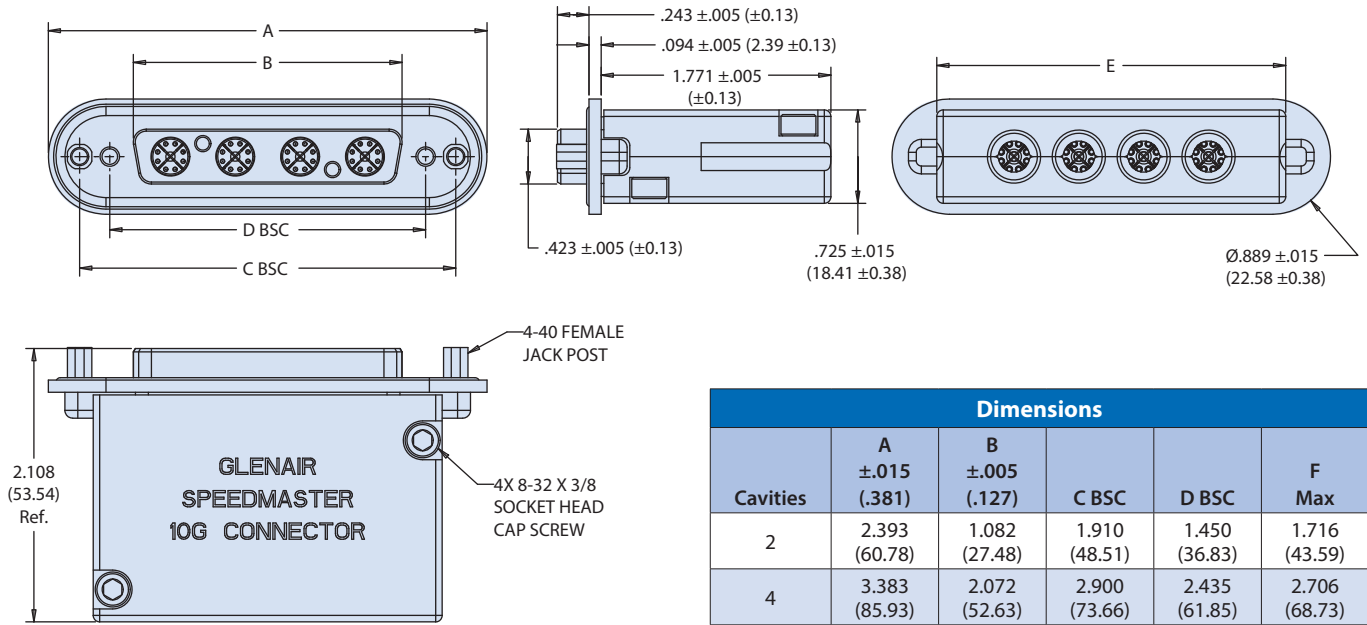

280-099 HIPER-D REAR PANEL MOUNT CONNECTOR, RECEPTACLE

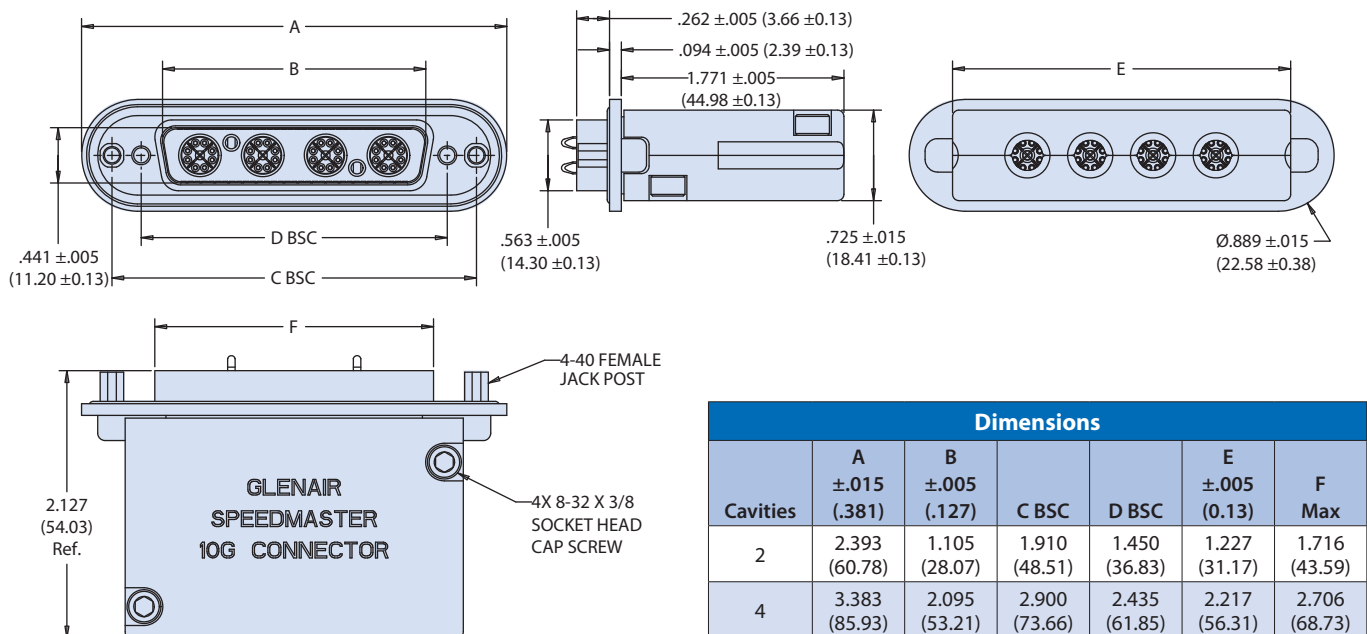



SERIES 28

HiPer-D M24308 connectors with SpeedMaster™ 10G high-speed contacts



HiPer-D Float Mount Connectors - How to Order

Part Number Development						
Sample Part Number	280-103M	4	P	MT	N	-1
Series	280-103M = Float mount plug 280-100F = Float mount receptacle					
Cavity Count	2 = 2 Cavities 4 = 4 Cavities					
Module Type	P = Pin S = Socket A = Less contacts; see note 1					
Material and Finish	NF = Aluminum alloy / Cadmium olive drab over electroless nickel MT = Aluminum alloy / nickel-PTFE ME = Aluminum alloy / electroless nickel ZR = Aluminum alloy / zinc nickel black RoHs compliant					
Hardware Options	N = No hardware					
Cable Size	See cable size table; omit for preterminated contact modules					

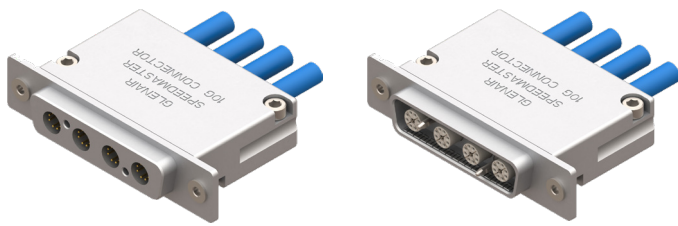

Cable Size	
Cable Size	Cable Diameter
1	.280 (7.11)
2	.274 (6.96)
3	.260 (6.60)
4	.250 (6.35)
5	.240 (6.10)
6	.230 (5.84)
7	.220 (5.59)

Cables*					
Cable P/N	Cable Category	Cable Construction	Wire Gage	Cable Dia.	Assembly Instructions
963-003-24	Cat 6A	SF/UTP	24	.280 (7.11)	AI85082
963-003-26	Cat 6A	SF/UTP	26	.220 (5.59)	
963-037	Cat 6A	SF/UTP	24	.260 (6.60)	

*Contact factory to inquire about use with other cables

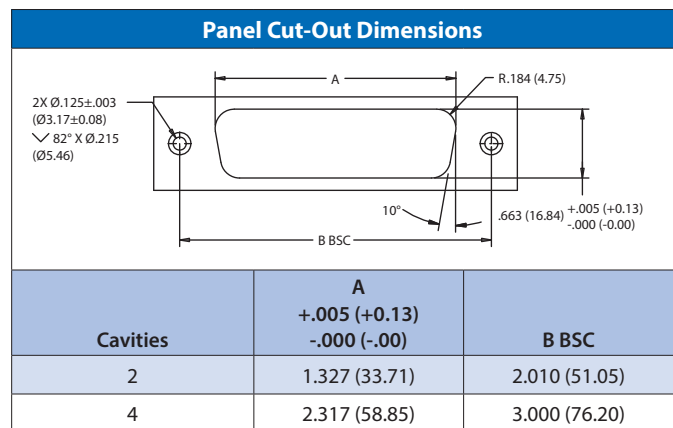

NOTES

- Spare high-speed modules (858-100, 858-101) may be ordered separately. Module wrench tool (607-011) supplied with each connector. Select the "less contacts (A)" option when ordering pre-terminated cable to SpeedMaster contacts listed on page 6 and 7. Omit cable size from part number development when selecting the "less contact" option from the module type of the part number development.
- See Assembly instructions AI 85082 for high-speed module terminations. See assembly instructions AI85089 for module installation.
- See page 8 for SpeedMaster module inner contact pinout
- For cables in-between sizes, select smaller size. Maximum cable diameter is .280 (7.11)
- Material / Finish:
 - Shells: part number development table
 - Hardware: stainless steel - passivated
 - Grounding spring: BeCu alloy / electroless nickel
 - Seals, o-ring: fluorosilicone blend / N.A.

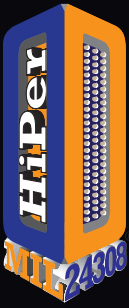

SERIES 28



HiPer-D M24308 connectors with SpeedMaster™ 10G high-speed contacts

Hiper-D Float Mount Connectors - Dimensions

280-103 HIPER-D FLOAT MOUNT CONNECTOR, PLUG

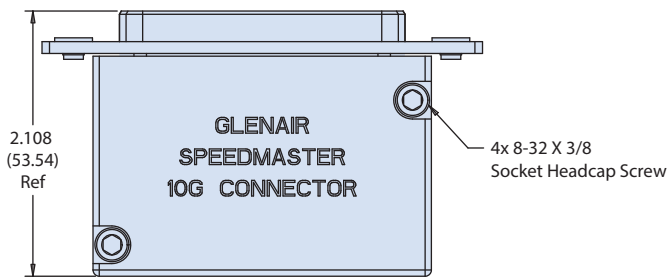
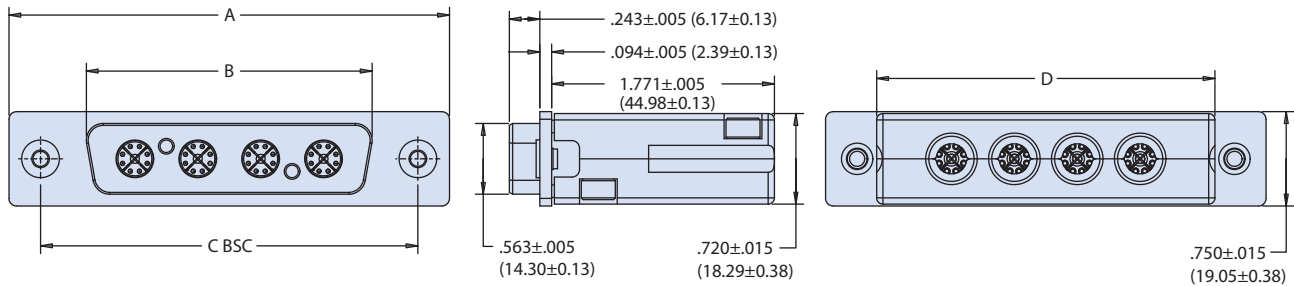

Dimensions				
	A	B	C BSC	D Max
Cavities	±.015 (.381)	±.005 (.127)		
2	2.512 (63.80)	1.227 (31.17)	2.010 (51.05)	1.716 (43.59)
4	3.502 (88.95)	2.217 (56.31)	3.000 (76.20)	2.706 (68.73)

280-100 HIPER-D FLOAT MOUNT CONNECTOR, RECEPTACLE

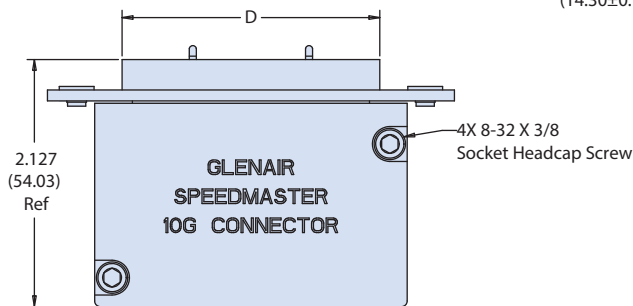
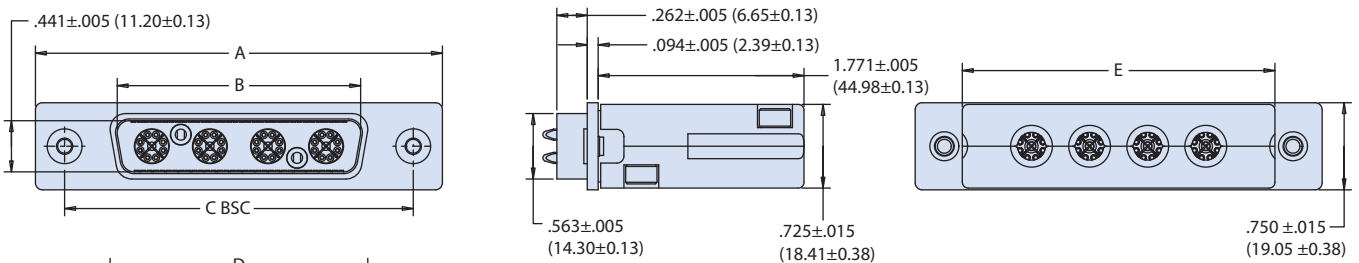

Dimensions					
	A	B	C BSC	D	E
Cavities	±.015 (.381)	±.005 (.127)		±.005 (0.13)	Max
2	2.512 (63.80)	1.105 (28.07)	2.010 (51.05)	1.227 (31.17)	1.716 (43.59)
4	3.502 (88.95)	2.095 (53.21)	3.000 (76.20)	2.217 (56.31)	2.706 (68.73)



SERIES 23

38999 type connectors with SpeedMaster™ 10G high-speed contacts



Product Specifications and Summary

Performance Specification, IAW MIL-DTL-32546, MIL-DTL-38999 Series III Rev. M, TIA-568-C.2, and Glenair SpeedMaster™						
Test	Test Requirement				Requirement Met	
High-speed Performance*	Individual contact modules meet the performance requirements of TIA-568-C.2: • Return Loss • Insertion Loss • NEXT • PS NEXT • ACR-F • PS ACR-F • ACR-N				Meets TIA-568-C.2, section 6.2	
Temperature Cycling†	Mated connectors shall be tested as specified in EIA-364-32, Method A, Condition VI -65°C to +200°C					
Mating/Unmating Forces	Maximum Engagement & Disengagement		Minimum Disengagement		Meets MIL-DTL-38999, paragraph 3.11	
	Shell Size	Pound inch	Newton meters	Pound inch		Newton meters
	11*	12	1.4	2		0.2
	19‡	28	3.2	3		0.3
	21‡	32	3.6	5		0.6
25*	40	4.6	5	0.6		
Durability*	No electrical or mechanical defects after 500 cycles of engagement and disengagement				Meets MIL-DTL-32546, paragraph 3.11	
Altitude Immersion	Mated connectors shall be tested as specified in EIA-364-03 75,000 ft equivalent					
Insulation Resistance at Ambient Temperature*	Unmated connectors shall be tested as specified in EIA-364-21 5000 megaohms min. at 25°C				Meets MIL-DTL-32546, paragraph 3.13.1	
Insulation Resistance at Elevated Temperature*	Unmated connectors shall be tested as specified in EIA-364-21 1000 megaohms min. at 200°C					
Salt Spray‡	Finish		Corrosion Resistance		MIL-DTL-32546, paragraph 3.16 Finish ME: Meets Finishes MT, NF, & ZR: Exceeds	
	Electroless Nickel (ME)		48 hrs			
	PTFE/Nickel (MT)		500 hrs			
	OD Cadmium (NF)		500 hrs			
	Black Zinc-Nickel (ZR)		500 hrs			
Vibration, Sine	No discontinuity greater than 1 microsecond, no cracking, breaking, or loosening of parts, plug shall not become disengaged from the receptacle. Connectors shall meet electrical requirements after test. 60 G's					
Vibration, Random at Ambient Temperature*	No discontinuity greater than 1 microsecond, no cracking, breaking, or loosening of parts, plug shall not become disengaged from the receptacle. Connectors shall meet electrical requirements after test. 49 G's rms				Meets MIL-DTL-32546, paragraph 3.21	
Standard Shock*	No loosening of parts, cracking, or other deleterious results hindering further part operation after 300 G's in each of 3 mutually perpendicular planes				Meets MIL-DTL-32546, paragraph 3.22	
High Impact Shock	Mated connectors equipped with straight environmentally sealed backshells shall withstand high impact shock per MIL-S-901, lightweight, Grade A					
Shell-to-Shell Conductivity‡	Finish		Maximum Millivolt Drop		Exceeds MIL-DTL-32546, paragraph 3.23	
	Electroless Nickel (ME)		1.0 mv			
	PTFE/Nickel (MT)		2.5 mv			
	OD Cadmium (NF)		2.5 mv			
	Black Zinc-Nickel (ZR)		2.5 mv			



SERIES 23

38999 type connectors with SpeedMaster™ 10G high-speed contacts



Product Specifications and Summary

Performance Specification, IAW MIL-DTL-32546, MIL-DTL-38999 Series III Rev. M, TIA-568-C.2, and Glenair SpeedMaster™

Humidity*

Testing shall be performed as specified in EIA-364-21, Method IV

Meets MIL-DTL-32546, paragraph 3.25

	Leakage Attenuation Min (dB)			Leakage Attenuation Min (dB)			
	Frequency (MHz)	Finish ME	Finishes MT, NF, ZR	Frequency (MHz)	Finish ME	Finishes MT, NF, ZR	
Shielding Effectiveness‡	100	90	90	1,500	76	69	Meets MIL-DTL-32546, paragraph 3.27
	200	88	88	2,000	70	65	
	300	88	88	3,000	69	61	
	400	87	87	4,000	68	58	
	800	85	85	6,000	66	55	
	1,000	85	85	10,000	65	50	

Fluid Immersion

No visible damage from immersion in various fuels and oils. Electrical performance requirements shall still be met.

* Indicates that test has been performed/data is available

† Thermal cycling has been done from -55°C to +200°C

‡ Qualification by similarity

38999 SPEEDMASTER SUMMARY

Standard Material and Finishes

- Shell, Barrel, Coupling Nut, Jam Nut: Aluminum alloy per ASTM-B211.
- Grounding spring: BeCu alloy/electroless nickel finish
- Seals, O-Ring: Fluorosilicone Blend

Shell Type and Sizes

- Shell Type: D38999 Series III Type, sizes 11, 19, 21, 25



SERIES 23

38999 type connectors with SpeedMaster™ 10G high-speed contacts



233-219 Connectors - How To Order

SpeedMaster™ Connector Part Number Development	
Sample Part Number	233-219 -G6 ME 25 -7 P N -1
Series / Basic Part No.	SuperNine Environmental High-Speed connector
SpeedMaster™ Connector Style*	G6 = Plug 38999/26 05 = Receptacle, in-line 07 = Receptacle, jam-nut 38999/24 00 = Receptacle, wall mount 38999/20 CM = Receptacle, wall mount, metric clinch nuts CS = Receptacle, wall mount, standard clinch nuts DO = Receptacle, wall mount, thru holes HM = Receptacle, wall mount, metric helicoils HS = Receptacle, wall mount, standard helicoils TO = Receptacle, wall mount, tapped holes
Material/Finish	NF = Cadmium Olive Drab ZR = Black Zinc Nickel MT = Nickel PTFE ME = Electroless Nickel
Shell Size	11, 19, 21, 25
Insert Arrangement	See Insert Arrangement Table
Module Type	P = Pin S = Socket A = Less contacts; see note 1
Alternate Polarization	A, B, C, D, E, N = Normal (IAW MIL-DTL-38999 Series III); See alternate positions table.
Cable Size	See Cable Size Table for details; omit for pre-terminated contact modules

Insert Arrangements			
11-1	19-3	21-4	25-7

NOTES

1. Spare High-Speed modules (858-100, 858-101) may be ordered separately. Module wrench tool (607-011) supplied with each connector. Select the "less contacts (A)" option when ordering pre-terminated cable to SpeedMaster contacts listed on page 6. Omit cable size from part number development when selecting the "less contact" option from the module type of the part number development.
2. See assembly instructions A185082 for high-speed module assembly. See assembly instructions A185086 for module installation.
3. Unless otherwise specified, all dimensions are per MIL-DTL-38999/20, /24 and /26
4. For cables in between sizes, select the smaller size
5. See page 8 for SpeedMaster module inner contact pinout
6. Glenair 233-219 connectors only accommodate Glenair SpeedMaster contacts.
7. SpeedMaster insert arrangements are exclusive to SpeedMaster and are unrelated to other insert patterns of the same size and arrangement

Alternate Positions						
Shell Size Code	Shell Size	Position Code	AR° AP°	BR° BP°	CR° CP°	DR° DP°
B	11	N	95	141	208	236
		A	113	156	182	292
		B	90	145	195	252
		C	53	156	220	255
		D	119	146	176	298
F G J	19 21 25	N	80	142	196	293
		A	135	170	200	310
		B	49	169	200	244
		C	66	140	200	257
		D	62	145	180	280
		E	79	153	197	272

Receptacle (Face)

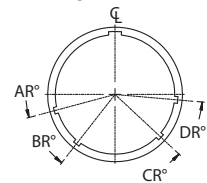

Plug (Face)

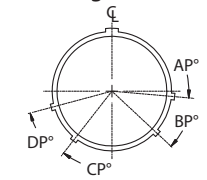

Cable Size			
Cable Size	Cable Ø	Cable Size	Cable Ø
1	.280 (7.11)	5	.240 (6.10)
2	.270 (6.86)	6	.230 (5.84)
3	.260 (6.60)	7	.220 (5.59)
4	.250 (6.35)		

SpeedMaster™ High-Speed Cable					
Cable P/N	Cabel Category	Cable Construction	Wire Gage	Cable Dia.	Assembly Instruction
963-003-24	Cat 6A	SF/UTP	24	.280	A185082
963-003-26	Cat 6A	SF/UTP	26	.220	
963-037	Cat 6A	SF/UTP	24	.260	
963-033-24	CAT 6A	S/FTP	24	.260	
933-033-26	CAT 6A	S/FTP	26	.220	

PLUG (G6) D38999/26 TYPE

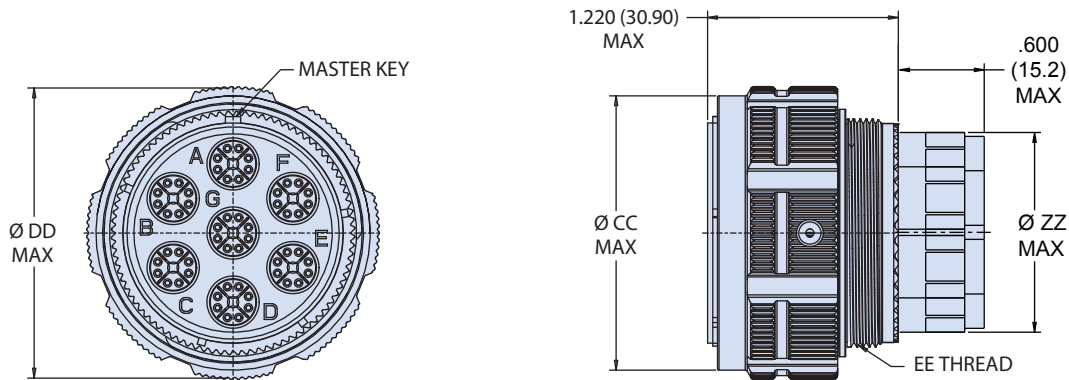

G6 Plug Per MIL-DTL-38999/26

Shell Size Code	Shell Size	$\varnothing CC$ Max	$\varnothing DD$ Max	EE Thread	$\varnothing ZZ$ Max
B	11	.929 (23.60)	.984 (24.99)	M15x1.0-6g 0.100R	.405 (10.29)
F	19	1.469 (37.31)	1.516 (38.51)	M28x1.0-6g 0.100R	.885 (22.48)
G	21	1.594 (40.49)	1.642 (41.71)	M31x1.0-6g 0.100R	.845 (21.46)
J	25	1.843 (46.81)	1.890 (48.01)	M37x1.0-6g 0.100R	1.285 (32.64)

IN-LINE (05) RECEPTACLE

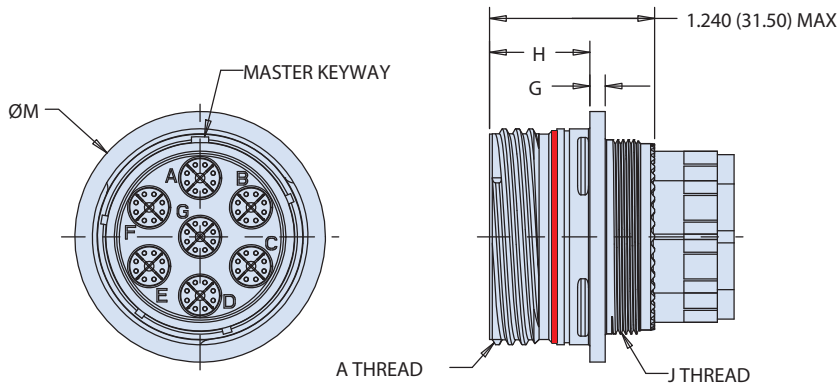

05 In-Line Receptacle

Shell Size Code	Shell Size	A Thread	G	H	J THREAD	$\varnothing M$
B	11	.7500-.1P-.3L-TS-2A	.098 (2.49)	.820 (20.83)	M15x1.0-6g 0.100R	.984 (24.99)
F	19	1.2500-.1P-.3L-TS-2A	.083 (2.11)	.771 (19.58)	M28x1.0-6g 0.100R	1.516 (38.51)
G	21	1.3750-.1P-.3L-TS-2A	.126 (3.20)	.790 (20.07)	M31x1.0-6g 0.100R	1.642 (41.71)
J	25	1.6250-.1P-.3L-TS-2A	.083 (2.11)	.741 (18.82)	M37x1.0-6g 0.100R	1.890 (48.01)

JAM-NUT (07) MOUNT RECEPTACLE, D38999/24 TYPE

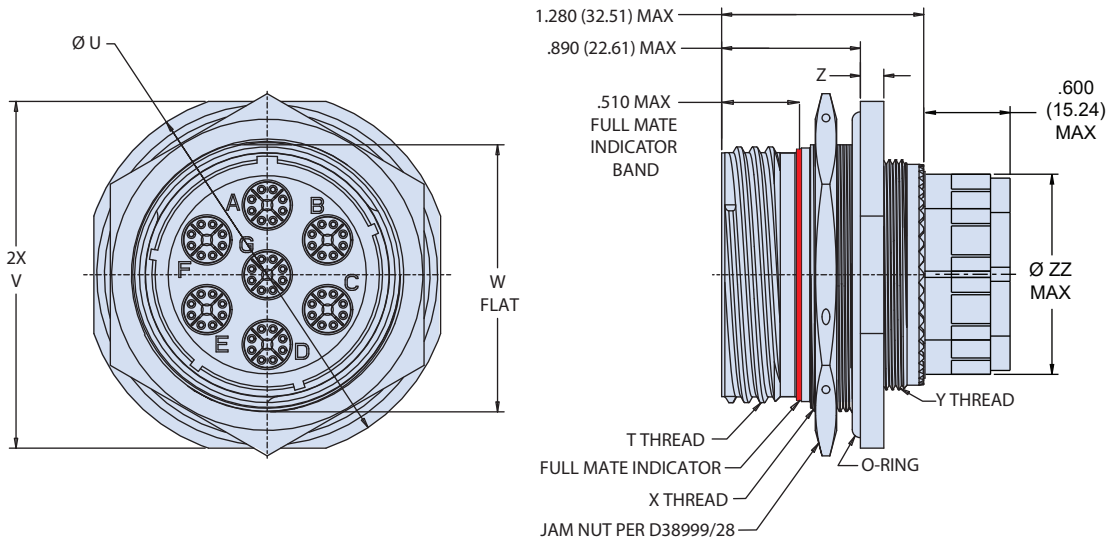

07 Jam Nut Per MIL-DTL-38999/24									
Shell Size Code	Shell Size	T Thread	U	V	W Flat	X Thread	Y Thread	Z	ZZ Max
B	11	.7500-.1P-.3L-TS-2A	1.385 (35.18) 1.363 (34.62)	1.267 (32.18) 1.237 (31.42)	0.756 (19.20) 0.746 (18.95)	M20x1.0-6g 0.100R	M15x1.0-6g 0.100R	.122 (3.10) .083 (2.11)	.405 (10.29)
F	19	1.2500-.1P-.3L-TS-2A	1.949 (49.50) 1.925 (48.89)	1.827 (46.41) 1.795 (45.59)	1.316 (33.43) 1.306 (33.17)	M35x1.0-6g 0.100R	M28x1.0-6g 0.100R	.153 (3.89) .114 (2.90)	.885 (22.48)
G	21	1.3750-.1P-.3L-TS-2A	2.075 (52.70) 2.051 (52.10)	1.953 (49.61) 1.921 (48.79)	1.441 (36.60) 1.431 (36.35)	M38x1.0-6g 0.100R	M31x1.0-6g 0.100R		.845 (21.46)
J	25	1.6250-.1P-.3L-TS-2A	2.323 (59.00) 2.299 (58.39)	2.205 (56.01) 2.173 (55.19)	1.691 (42.95) 1.681 (42.70)	M44x1.0-6g 0.100R	M37x1.0-6g 0.100R		1.285 (32.64)

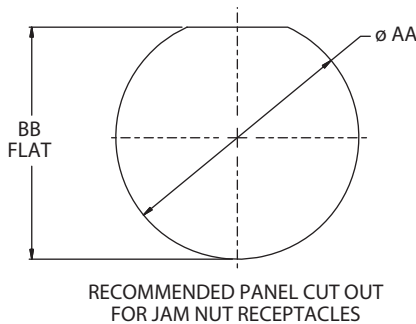

Mounting Holes Per MIL-DTL-38999			
Shell Size Size	Shell Size	$\varnothing AA$	BB Flat
B	11	0.835 (21.21) 0.825 (20.95)	0.771 (19.58) 0.761 (19.33)
F	19	1.395 (35.43) 1.385 (35.18)	1.335 (33.91) 1.325 (33.65)
G	21	1.520 (38.61) 1.510 (38.35)	1.460 (37.08) 1.450 (36.83)
J	25	1.770 (44.96) 1.760 (44.70)	1.710 (43.43) 1.700 (43.18)

SLOTTED HOLE (00), D38999/20 TYPE

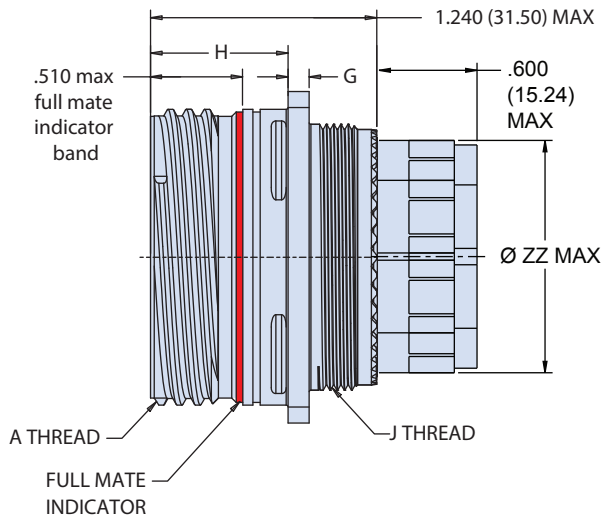
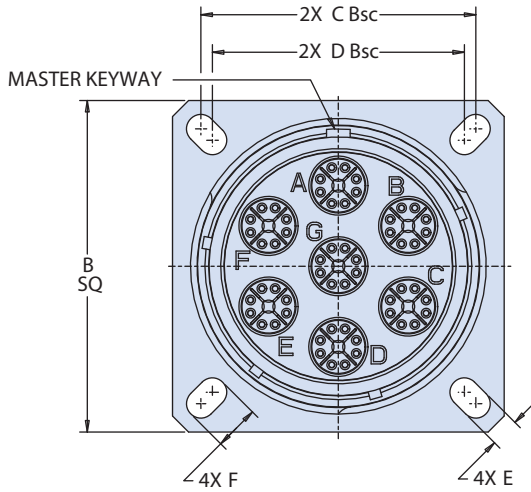

00 Wall Mount Per MIL-DTL-38999/20											
Shell Size Code	Shell Size	A Thread	B	C BSC	D BSC	E	F	G	H	J THREAD	ZZ Max
B	11	.7500-.1P-.3L-TS-2A	1.040 (26.42) 1.016 (25.81)	.812 (20.62)	.719 (18.26)	.136 (3.45) .120 (3.05)	.198 (5.03) .190 (4.83)	.098 (2.49) .083 (2.11)	.820 (20.83) .771 (19.58)	M15x1.0-6g 0.100R	.405 (10.29)
F	19	1.2500-.1P-.3L-TS-2A	1.449 (36.80) 1.425 (36.20)	1.156 (29.36)	1.062 (26.97)		.202 (5.13)				
G	21	1.3750-.1P-.3L-TS-2A	1.575 (40.00) 1.551 (39.40)	1.250 (31.75)	1.156 (29.36)	.186 (4.72)	.250 (6.35) .234 (5.94)	.083 (2.11)	.741 (18.82)	M31x1.0-6g 0.100R	.845 (21.46)
J	25	1.6250-.1P-.3L-TS-2A	1.823 (46.30) 1.799 (45.69)	1.500 (38.10)	1.375 (34.92)	.142 (3.61)					

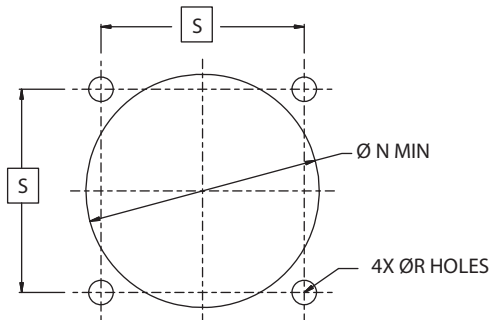

Mounting Holes Per MIL-DTL-38999				
Shell Size	Shell Size	Ø N Min	Ø R Holes	S BSC
B	11	.796 (20.22)	.133 (3.38) .123 (3.12)	.812 (20.62)
F	19	1.297 (32.94)		1.156 (29.36)
G	21	1.422 (36.12)	.155 (3.94) .145 (3.68)	1.250 (31.75)
J	25	1.672 (42.47)		1.500 (38.10)

RECOMMENDED MOUNTING HOLES FOR WALL MOUNT (00) RECEPTACLES PER MIL-DTL-38999.

CLINCH NUT STANDARD (CS) AND METRIC (CM), THRU HOLES (DO) AND TAPPED HOLES (TO)

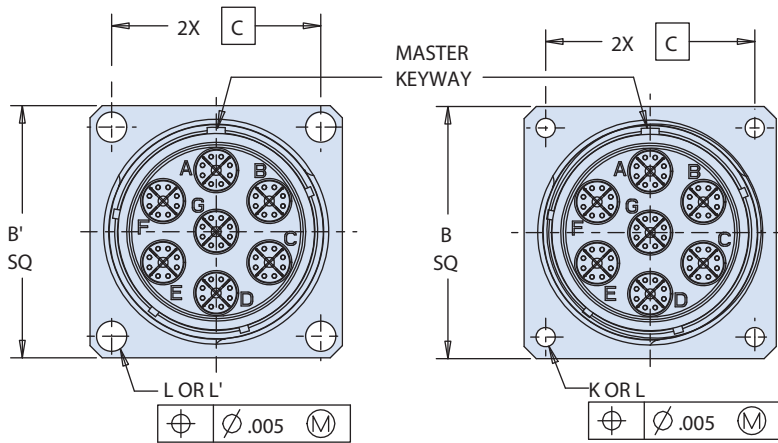

CM & CS STYLE

DO & TO STYLE

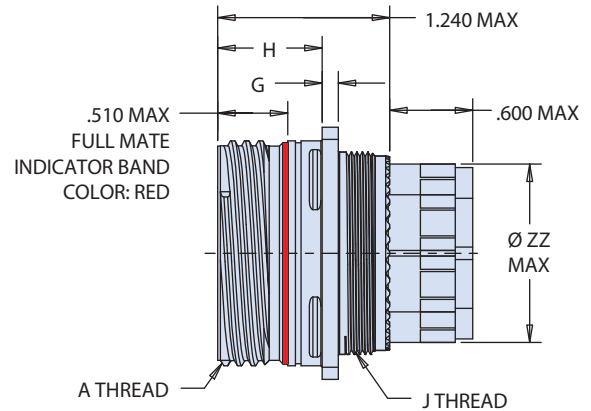

CM, CS, DO, & TO STYLE

CM, CS, DO and TO Wall Mount														
Shell Size Code	Shell Size	A Thread	B SQ	B' SQ	C BSC	G	H	J THREAD	ØK	L Standard	L' Metric	ZZ Max		
B	11	.7500-.1P-.3L-TS-2A	1.043 (26.49) 1.019 (25.88)	1.187 (30.15) 1.147 (29.13)	.812 (20.62)	.098 (2.49) .083 (2.11)	.820 (20.83) .771 (19.58)	M15x1.0-6g 0.100R	.136 (3.45) .120 (3.05)	.112-40 UNC-2B	M3 x 0.5	.405 (10.29)		
F	19	1.2500-.1P-.3L-TS-2A	1.449 (36.80) 1.425 (36.20)	1.531 (38.89) 1.491 (37.87)	1.156 (29.36)			M28x1.0-6g 0.100R						.885 (22.48)
G	21	1.3750-.1P-.3L-TS-2A	1.575 (40.00) 1.551 (39.40)	1.625 (41.28) 1.585 (40.26)	1.250 (31.75)	.126 (3.20) .083 (2.11)	.790 (20.07) .741 (18.82)	M31x1.0-6g 0.100R						
J	25	1.6250-.1P-.3L-TS-2A	1.823 (46.30) 1.799 (45.69)	1.875 (47.63) 1.835 (46.61)	1.500 (38.10)			M37x1.0-6g 0.100R	.162 (4.11) .146 (3.71)	.138-32 UNC-2B	M4 x 0.7	1.285 (32.64)		

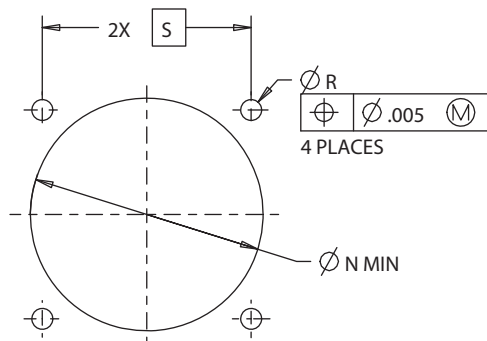

Mounting Holes				
Shell Size	Shell Size	Ø N Min	Ø R Holes	S BSC
B	11	.796 (20.22)	.133 (3.38) .123 (3.12)	.812 (20.62)
F	19	1.297 (32.94)		1.156 (29.36)
G	21	1.422 (36.12)		1.250 (31.75)
J	25	1.672 (42.47)	.155 (3.94) .145 (3.68)	1.500 (38.10)

HELICOILS STANDARD (HS) AND METRIC (HM)

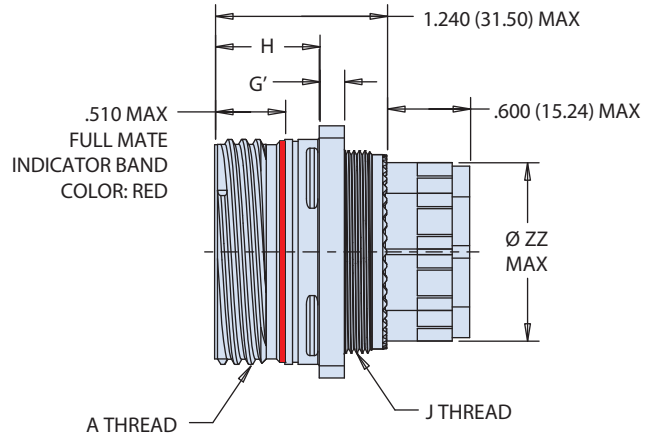
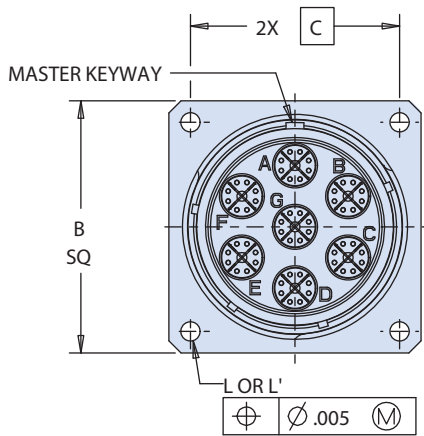

HM & HS STYLE

HM and HS Wall Mount										
Shell Size Code	Shell Size	A Thread	B SQ	C BSC	G'	H	J THREAD	L Thread (Standard)	L' Thread (Metric)	ZZ Max
B	11	.7500-.1P-.3L-TS-2A	1.043 (26.49) 1.019 (25.88)	.812 (20.62)	.179 (4.55) .140 (3.56)	.820 (20.83)	M15x1.0-6g 0.100R	.112-40 UNC-2B	M3 x 0.5	.405 (10.29)
F	19	1.2500-.1P-.3L-TS-2A	1.449 (36.80) 1.425 (36.20)	1.156 (29.36)		.771 (19.58)	M28x1.0-6g 0.100R			.885 (22.48)
G	21	1.3750-.1P-.3L-TS-2A	1.575 (40.00) 1.551 (39.40)	1.250 (31.75)		.790 (20.07)	M31x1.0-6g 0.100R			.845 (21.46)
J	25	1.6250-.1P-.3L-TS-2A	1.823 (46.30) 1.799 (45.69)	1.500 (38.10)	.190 (4.83) .170 (4.32)	.741 (18.82)	M37x1.0-6g 0.100R	.138-32 UNC-2B	M4 x 0.7	1.285 (32.64)

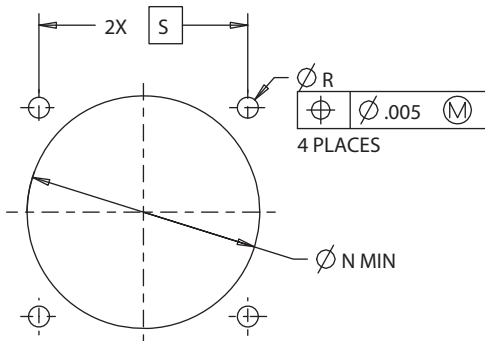

Mounting Holes				
Shell Size Size	Shell Size	Ø N Min	Ø R Holes	S BSC
B	11	.796 (20.22)	.133 (3.38) .123 (3.12)	.812 (20.62)
F	19	1.297 (32.94)		1.156 (29.36)
G	21	1.422 (36.12)	.155 (3.94) .145 (3.68)	1.250 (31.75)
J	25	1.672 (42.47)		1.500 (38.10)



SERIES 23

38999 type connectors with SpeedMaster™ 10G high-speed contacts



233-220 Wall Mount, PC Tail Receptacle - How To Order

Part Number Development							
Sample Part Number	233-220 -07 ME 25 -7 P N						
Series / Basic Part No.	SuperNine Environmental High-Speed connector						
Connector Style*	See connector type table						
Material/Finish	NF = Cadmium Olive Drab ZR = Black Zinc Nickel		MT = Nickel PTFE ME = Electroless Nickel				
Shell Size	11, 19, 21, 25						
Insert Arrangement	See Insert Arrangement Table						
Module Type	P = Pin S = Socket						
Alternate Polarization	A, B, C, D, E, N = Normal (IAW MIL-DTL-38999 Series III); See alternate positions table.						



Socket Module



Pin Module

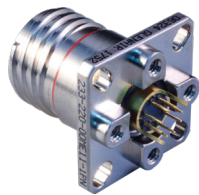

NOTES

- Only mates with Glenair SpeedMaster plug of same keying insert arrangement. Mating connector must have 1.5 meters minimum of cable length
- All inserts have ground plane

Connector Style	
Symbol	Description
00	Wall mount receptacle with slotted holes, standard standoff threads
10	Wall mount receptacle with slotted holes, metric standoff threads
CM	Wall mount receptacle with metric clinch nuts
CS	Wall mount receptacle with standard clinch nuts
HM	Wall mount receptacle with metric helicoils
HS	Wall mount receptacle with standard helicoils
07	Jam-nut receptacle

Insert Arrangements			
11-1	19-3	21-4	25-7

Alternate Positions						
Keyway Positions (Receptacle)						
Shell Size Code	Shell Size	Alternate Position Code	AR°	BR°	CR°	DR°
B	11	N	95	141	208	236
		A	113	156	182	292
		B	90	145	195	252
		C	53	156	220	255
		D	119	146	176	298
F G J	19 21 25	N	80	142	196	293
		A	135	170	200	310
		B	49	169	200	244
		C	66	140	200	257
		D	62	145	180	280
		E	79	153	197	272

WALL MOUNT PANEL MOUNTING HOLES

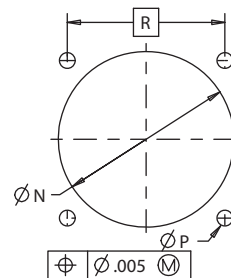

Mounting Hole Dimensions			
Shell Size	ØN Min	ØP Holes	R Typ
11	.796 (20.2)	.133 (3.4)	.812 (20.6)
19	1.297 (32.9)		1.156 (29.4)
21	1.422 (36.1)	.155 (3.9) .145 (3.7)	1.250 (31.8)
25	1.672 (42.5)		1.500 (38.1)



SERIES 23

38999 type connectors with SpeedMaster™ 10G high-speed contacts



233-220 PC Tail, Wall Mount Receptacle - Dimensions

00, 10, CM, CS, HM, AND HS - WALL MOUNT RECEPTACLES WITH SLOTTED HOLES D38999/20 TYPE

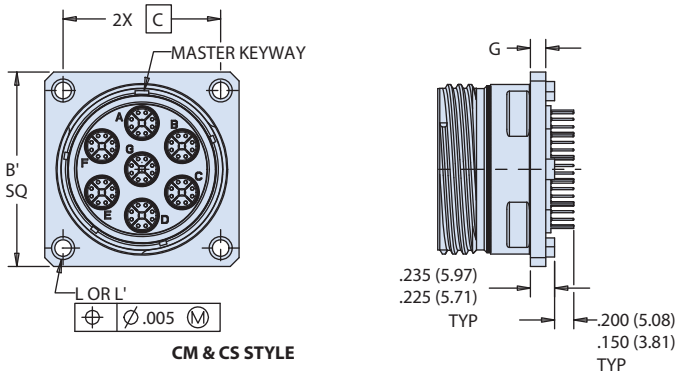
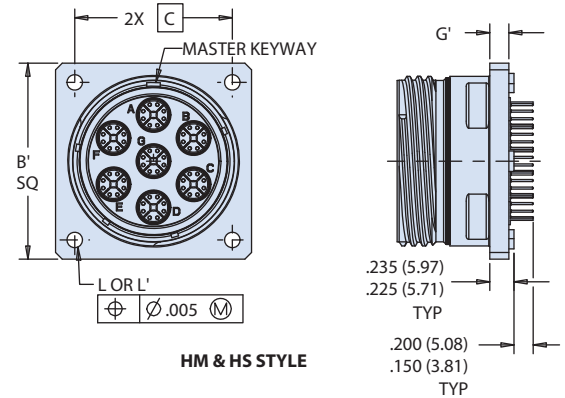
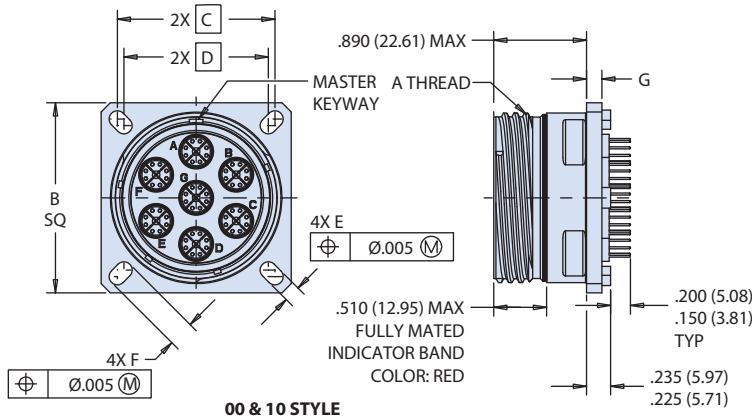

Rear view applies to all connector styles

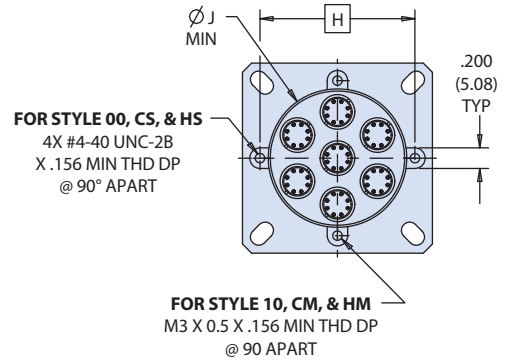

Dimensions														
Shell Size	A Thread -0.1P-0.3L-TS-2A	B Sq	B' Sq	C Bsc	D Bsc	E	F	G	G'	H Bsc	ØJ Min	L	L'	
11	.7500	1.043 (26.49) 1.019 (25.88)	1.187 (30.15) 1.147 (29.13)	.812 (20.62)	.719 (18.26)			.122 (3.10) .083 (2.11)	.179 (4.55)	.719 (18.26)	.468 (11.89)			
19	1.2500	1.449 (36.80) 1.425 (36.20)	1.531 (38.89) 1.491 (37.87)	1.156 (29.36)	1.062 (26.97)	.136 (3.45) .120 (3.05)	.202 (5.13) .186 (4.72)	.153 (3.89) .114 (2.90)	1.15 (29.21)	1.15 (29.21)	.934 (23.72)	.112-40 UNC-2B	M3x0.5	
21	1.3750	1.575 (40.00) 1.551 (39.40)	1.625 (41.28) 1.585 (40.26)	1.250 (31.75)	1.156 (29.36)				1.221 (31.01)	1.221 (31.01)	1.055 (26.80)			
25	1.6250	1.823 (46.30) 1.799 (45.69)	1.875 (47.63) 1.835 (46.61)	1.500 (38.10)	1.375 (34.92)	.250 (6.35) .234 (5.94)	.250 (6.35) .234 (5.94)		1.475 (37.47)	1.745 (44.32)	1.307 (33.20)			.138-32 UNC-2B

07- JAM-NUT MOUNT RECEPTACLE D38999/24 TYPE

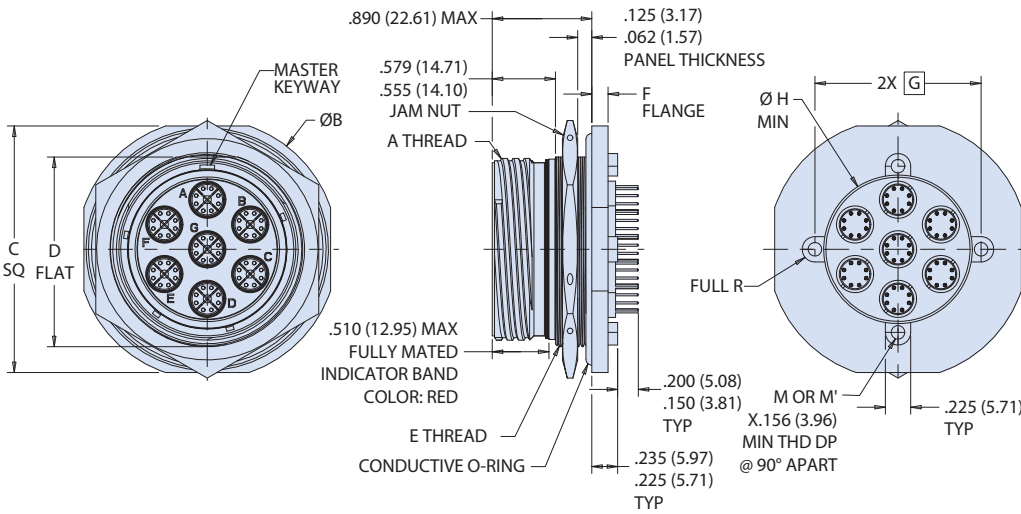

PANEL CUT-OUT

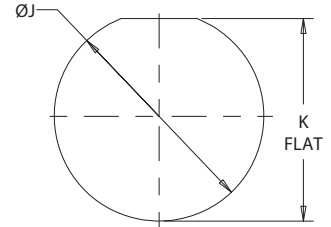

Dimensions		
Shell Size	ØJ ±0.010	K Flat
11	.830 (21.08)	.766 (19.46)
19	1.390 (35.31)	1.330 (33.78)
21	1.515 (38.48)	1.455 (36.96)
25	1.765 (44.83)	1.705 (43.31)

Dimensions										
Shell Size	A Thread -0.1P-0.3L-TS-2A	ØB	C Sq	D Flat	E Thread ISO Metric	F	G	ØH Min	Threads	
									M	M'
11	.7500	1.386 (35.20) 1.362 (34.59)	1.268 (32.21) 1.263 (32.08)	0.755 (19.18) 0.745 (18.92)	M20 X 1.0-6g	0.122 (3.10) 0.083 (2.11)	0.719 (18.26)	0.468 (11.89)	.112-40 UNC-2B	M3 X .05
21	1.3750	2.075 (52.71) 2.051 (52.10)	1.953 (49.61) 1.921 (48.79)	1.441 (36.60) 1.431 (36.35)	M38 X 1.0-6g	1.221 (31.01)	1.055 (26.80)			
								25		

PCB FOOTPRINTS

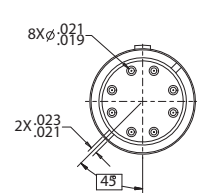
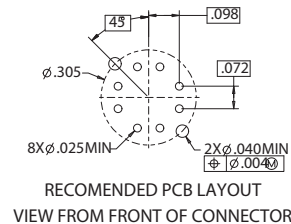
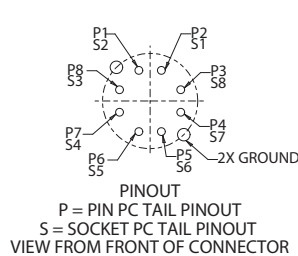
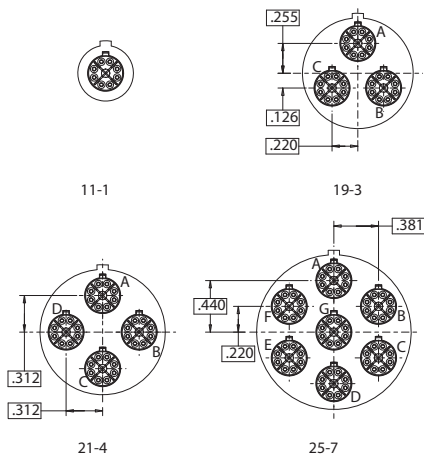



SERIES 23

38999 type connectors with SpeedMaster™ 10G high-speed contacts



233-263 Hermetic Bulkhead Feedthru - How to Order

Part Number Development	
Sample Part Number	233-263 -H7 ZL 25 -7 S N -2
Series - Basic Part No.	233-263 = SuperNine Hermetic High-Speed Bulkhead Feedthru
Connector Style*	H2 = Square Flange Mount H7 = Jam-Nut Mount DH7 = Dual O-ring Jam-Nut Mount H8 = Weld Mount
Material/Finish	Z1 = 300 Series CRES; Passivated ZL = 300 Series CRES; Electroless Nickel
Shell Size	11, 19, 21, 25
Insert Arrangement	See Insert Arrangement Table
Module Type	P = Pin S = Socket A = Connector Less Contacts
Alternate Polarization	A, B, C, D, E, N = Normal (IAW MIL-DTL-38999 Series III); See alternate positions table.
Panel Thickness	2 = .250





SPEEDMASTER™ CONNECTORS

NOTES

- Contact factory for other plating options
- SpeedMaster insert arrangements are exclusive to SpeedMaster™ and are unrelated to other insert patterns of the same name
- Glenair 233-263 is only designed to mate with Glenair 233-219-G7 connector of the same shell size, polarization, and opposite gender
- Hermeticity: less than 1×10^{-7} ccHe/sec at 1 atmosphere differential.
- 233-263 connector is only available as pin to socket or socket to pin
- Contacts are non removable
- Material / Finish
 - Shell and jam-nut: CRES/passivate or CRES/nickel plate
 - Contacts pin: nickel/iron alloy/gold
 - Contacts sockets: copper alloy/gold
 - Insulator hermetic: full glass/N.A
 - Insulator socket: high grade dielectric/N.A
 - Grounding members: copper alloy/electroless nickel
 - Seals: fluorosilicone blend/N.A.

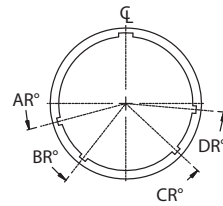
Receptacle, Alternate Keyway Positions



Shell Size Code	Shell Size	Alternate Position Code	AR°	BR°	CR°	DR°
B	11	N	95	141	208	236
		A	113	156	182	292
		B	90	145	195	252
		C	53	156	220	255
		D	119	146	176	298
F G J	19 21 25	N	80	142	196	293
		A	135	170	200	310
		B	49	169	200	244
		C	66	140	200	257
		D	62	145	180	280
		E	79	153	197	272

Insert Arrangements

11-1	19-3	21-4	25-7

H2 - SQUARE FLANGE MOUNT BULKHEAD FEED-THRU

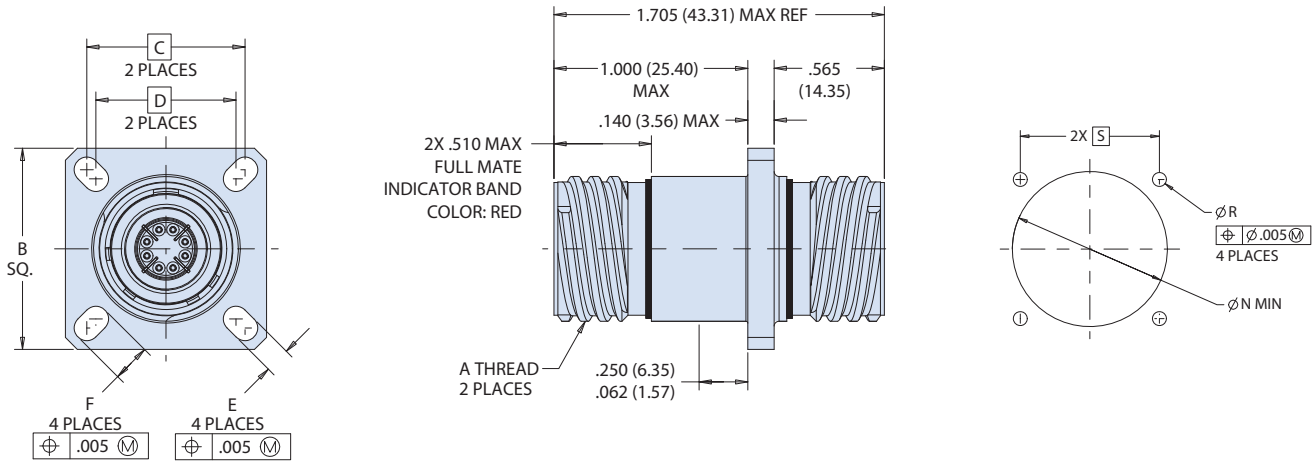

Square Flange Mount Dimensions								
Shell Size	A THREAD	B	C Basic	D Basic	E	F	ØR Holes	S Basic
11	.7500-.1P-.3L-TS-2A	1.040 (26.42) 1.016 (25.81)	0.812 (20.62)	0.719 (18.26)		0.198 (5.03) 0.190 (4.83)		0.812 (20.62)
19	1.2500-.1P-.3L-TS-2A	1.449 (36.80) 1.425 (36.20)	1.156 (29.36)	1.062 (26.97)	0.136 (3.45) 0.120 (3.05)	0.202 (5.13) 0.186 (4.72)	0.133 (3.38) 0.123 (3.12)	1.156 (29.36)
21	1.3750-.1P-.3L-TS-2A	1.575 (40.00) 1.551 (39.40)	1.250 (31.75)	1.156 (29.36)				1.250 (31.75)
25	1.6250-.1P-.3L-TS-2A	1.823 (46.30) 1.799 (45.69)	1.500 (38.10)	1.375 (34.92)	0.162 (4.11) 0.146 (3.71)	0.250 (6.35) 0.234 (5.94)	0.155 (3.94) 0.145 (3.68)	1.500 (38.10)

H8 - WELD MOUNT BULKHEAD FEED-THRU

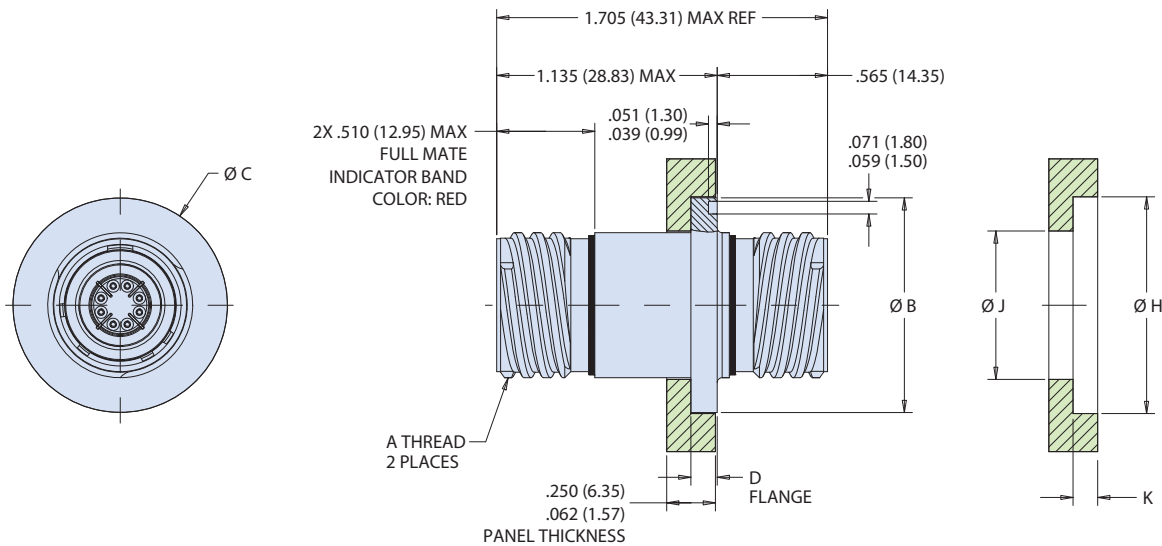

Weld Mount Dimensions							
Shell Size	A Thread	B	C	D	$\varnothing H$	$\varnothing J$	$\varnothing K \pm .005 (0.13)$
11	.7500-.1P-.3L-TS-2A	1.063 (27.00)	1.106 (28.09)		1.112 (28.24)	.760 (19.30)	.126 (3.20)
		1.051 (26.70)	1.094 (27.79)		1.107 (28.12)		
19	1.2500-.1P-.3L-TS-2A	1.547 (39.29)	1.591 (40.41)	0.134 (3.40)	1.597 (40.56)	1.260 (32.00)	
		1.535 (38.99)	1.579 (40.11)	0.118 (3.00)	1.592 (40.44)		
21	1.3750-.1P-.3L-TS-2A	1.689 (42.90)	1.732 (43.99)		1.738 (44.15)	1.385 (35.18)	
		1.677 (42.60)	1.720 (43.69)		1.733 (44.02)		
25	1.6250-.1P-.3L-TS-2A	1.941 (49.30)	1.984 (50.39)	0.165 (4.19)	1.990 (50.55)	1.635 (41.53)	
		1.929 (49.00)	1.972 (50.09)	0.149 (3.78)	1.985 (50.42)		

DH7 DUAL O-RING AND H7 SINGLE O-RING - JAM-NUT MOUNT BULKHEAD FEED-THRU

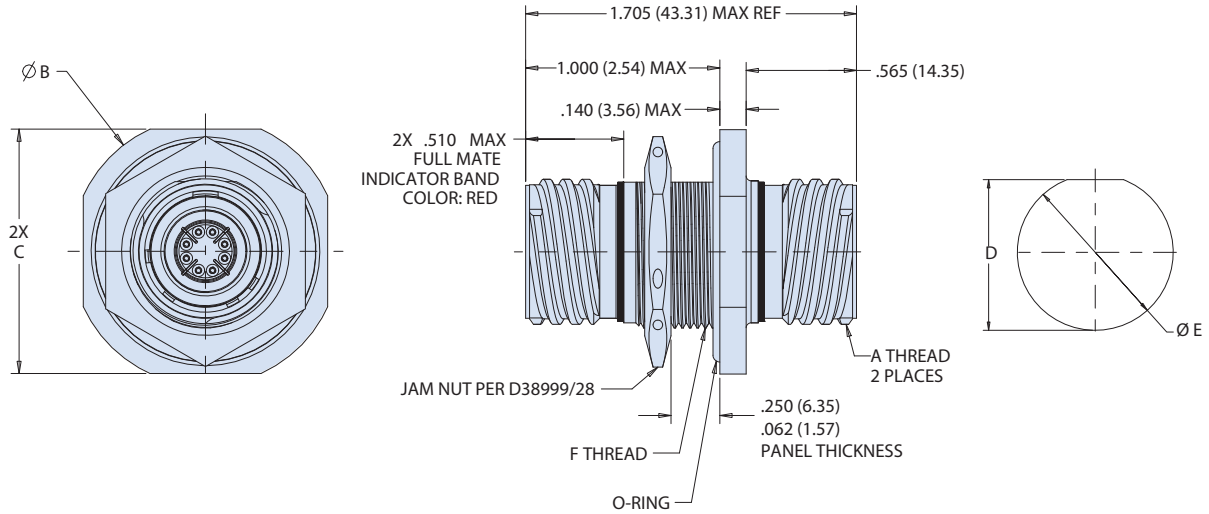

Jam-Nut Mount Dimensions				
Shell Size	A Thread	Ø B	C Max	F Thread
11	.7500-.1P-.3L-TS-2A	1.375 (34.92)	1.252 (31.80)	M20x1.0-6g 0.100R
19	1.2500-.1P-.3L-TS-2A	1.937 (49.20)	1.811 (46.00)	M35x1.0-6g 0.100R
21	1.3750-.1P-.3L-TS-2A	2.063 (52.40)	1.937 (49.20)	M38x1.0-6g 0.100R
25	1.6250-.1P-.3L-TS-2A	2.311 (58.70)	2.189 (55.60)	M44x1.0-6g 0.100R

Dual O-Ring Jam-Nut Mount Dimensions				
Shell Size	A Thread	Ø B	C Max	F Thread
11	.7500-.1P-.3L-TS-2A	1.625 (41.28)	1.500 (38.10)	M20x1.0-6g 0.100R
19	1.2500-.1P-.3L-TS-2A	2.189 (55.60)	2.063 (52.40)	M35x1.0-6g 0.100R
21	1.3750-.1P-.3L-TS-2A	2.311 (58.70)	2.189 (55.60)	M38x1.0-6g 0.100R
25	1.6250-.1P-.3L-TS-2A	2.625 (66.68)	2.400 (60.96)	M44x1.0-6g 0.100R

Jam-Nut Panel Cut-Out Dimensions		
SHELL SIZE	ØD	E FLAT
11	0.835 (21.21)	0.771 (19.58)
	0.825 (20.96)	0.761 (19.33)
19	1.395 (35.43)	1.335 (33.91)
	1.385 (35.18)	1.325 (33.65)
21	1.520 (38.61)	1.460 (37.08)
	1.510 (38.35)	1.450 (36.83)
	1.510 (38.35)	1.450 (36.83)
25	1.770 (44.96)	1.710 (43.43)
	1.760 (44.70)	1.700 (43.18)
	1.760 (44.70)	1.700 (43.18)



Aluminum alloy connector backshell for SuperNine® 38999 type SuperNine® connector

377-119 Aluminum Alloy Backshell - How to Order

Part Number Development										
Sample Part Number	377	N	S	119	MT	11	06	4	G	01
Series	377									
Connector Designator	N = Glenair SpeedMaster™ Connectors									
Angular Function	S = Straight N = 90° Solid Elbow M = 45° Solid Elbow									
Basic No.	119									
Material/Finish	See Finish Table									
Shell Size	11, 19, 21, 25									
Optional Entry Size	See Optional Entry Size Table									
Length	In 1/2 Inch Increments; e.g. 4 = 2 inches (see note 2)									
Adapter Style	G = Gland Nut K = Tubing Adapter with Nut, Glenair PEEK B = Banding Adapter 601 Series Band Supplied with Backshell									
Cable Diameter	See Cable Diameter Table									

Dimensions											
Shell Size	A Thread ISO Metric	B Max	D Max	E Max	F Max	G Max	H Ref	J Flats	Conduit Size Ref	Insert Identification	No. of Holes
11	M15 X 1 - 6H	1.06 (26.92)	1.78 (45.21)	1.93 (49.02)	1.33 (33.78)	1.56 (39.62)	.54 (13.72)	.938 (23.83)	7/16	11-1	1
19	M28 X 1 - 6H	1.54 (39.12)	2.11 (53.59)	2.18 (55.37)	1.54 (39.12)	1.77 (44.96)	1.00 (25.40)	1.250 (31.75)	3/4	19-3	3
21	M31 X 1 - 6H	1.67 (42.42)	2.07 (52.58)	2.25 (57.15)	1.61 (40.89)	1.84 (46.74)	1.00 (25.40)	1.500 (38.10)	7/8	21-4	4
25	M37 X 1 - 6H	2.12 (53.85)	2.19 (55.63)	2.19 (55.63)	1.73 (43.94)	1.96 (49.78)	1.27 (32.26)	1.812 (46.02)	1	25-7	7

Optional Entry Size		
Entry Size	C Ref Sym K	Opt. Conduit Size Ref.
06	.330 (8.38)	7/16
07	.390 (9.91)	1/2
08	.515 (13.10)	5/8
10	.640 (16.26)	3/4
11	.640 (16.26)	3/4
13	.765 (19.43)	7/8
15	.890 (22.61)	1
17	1.125 (28.58)	1 1/4

Cable Diameter		
Entry Size	P Approx	Cable Accomodation (Ref)
01	.280 (7.11)	963-003-24, 963-037, 963-033-24
07	.220 (5.59)	963-003-26, 964-963-26

Finish Table		
Sym	Finish Description	
M	Al alloy	Electroless nickel
MT		Nickel - PTFE
NF		Cad/O.D. over electroless nickel (100 hour salt spray)

Aluminum alloy connector backshell for SuperNine® 38999 type SuperNine® connector

377-119 Aluminum Alloy Backshell - Dimensions

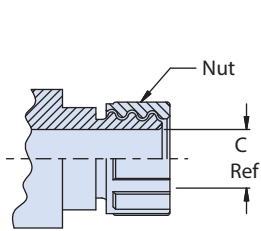

K - Peek Tubing Adapter with Nut

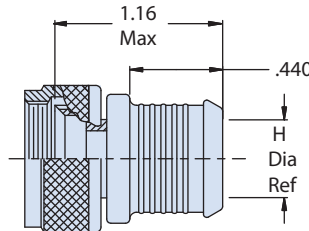

B - Banding Adapter

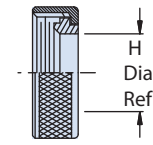

G - Gland Nut

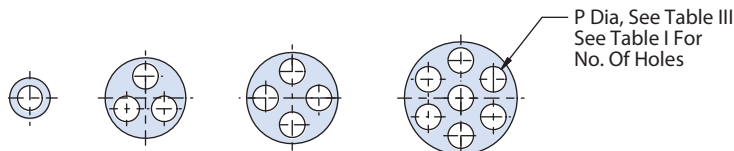
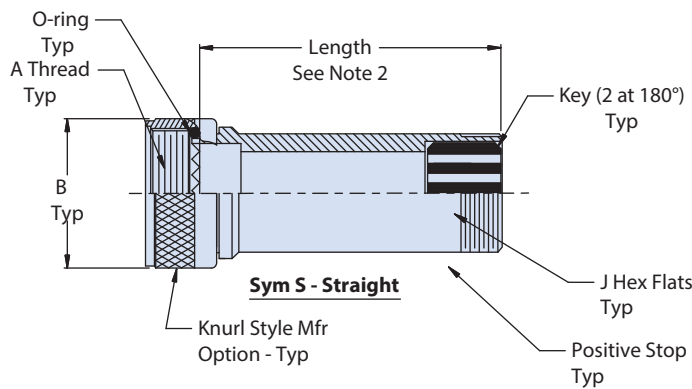
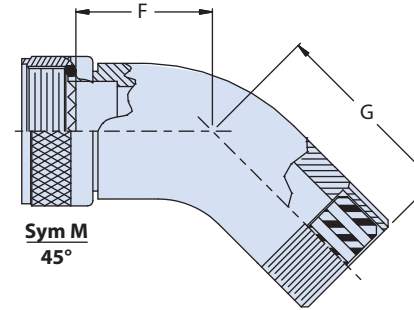
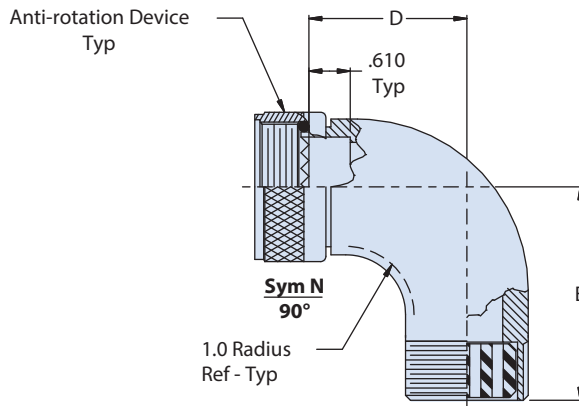

NOTES

- Glenair 600 series backshell assembly tools are recommended for assembly and installation
- Standard min. order length 1.5 inch, consult factory for shorter lengths
- Material:
 - Adapters, elbows, ferrules, coupling nut, nut: aluminum alloy/see finish table
 - Grommet, O-ring: fluorosilicone/N.A.
 - Anti-rotation device: corrosion resistant material/N.A.

SPEEDMASTER Assembly Instructions



AI85082 SpeedMaster™ Contact Module Assembly Instructions

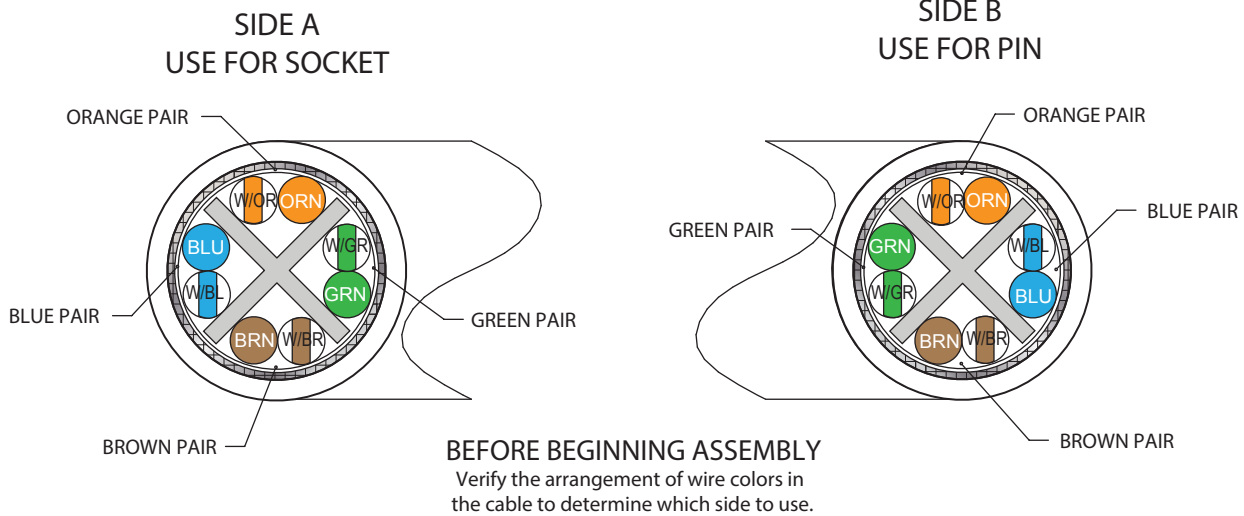

STEP 1

- A. Place o-ring onto thread ferrule so that it is seated behind the thread. (Figure 1)
- B. Slide retention ferrule with o-ring onto cable.

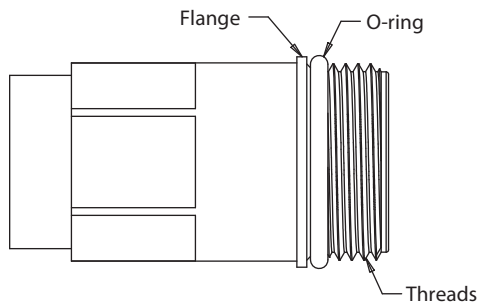

FIGURE 1

STEP 2

- A. Slide shield ferrule onto cable.
- B. Use proper tool to remove cable outer jacket to approximately 0.75 Inch.
- C. Comb braid out straight, and trim it to approximately .3 Inches. Fold braid back afterward.
- D. Trim outer tape, cable splice, and filler if any as close to the folded back braid shield as possible. (Figure 2)
- E. Use appropriate tool to strip the individual wires to .130 Inches max.

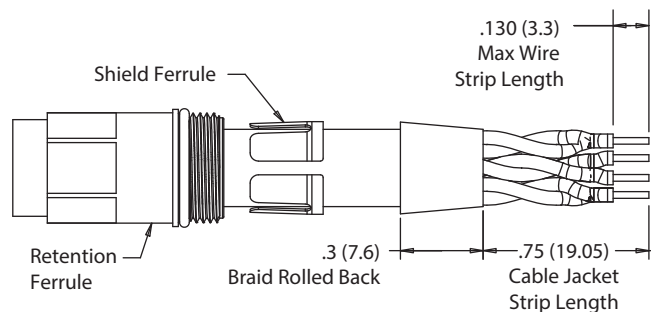

FIGURE 2

SPEEDMASTER Assembly Instructions



AI85082 SpeedMaster™ Contact Module Assembly Instructions

STEP 3

Maintain twist of pairs as best as possible. If needed – undo half a twist, do not over twist

- A. Crimp contacts onto each individual wire using Daniels crimp tool M22520/2-01 (Glenair P/N 809-015). Use Daniels positioner K41 (Glenair P/N 859-019) for sockets or positioner K42 (Glenair P/N 859-018) for pins.
- B. Insert each pair of wires into the appropriate quadrant on the isolator according to figure 3 for socket modules, and figure 4 for pin modules.

NOTES:

- C. Crossing of pairs is not recommended. (cables should only be terminated as pin to socket).
- D. Assembly instructions use socket module (858-100) for illustrations. Pin module (858-101) is assembled in the same fashion.

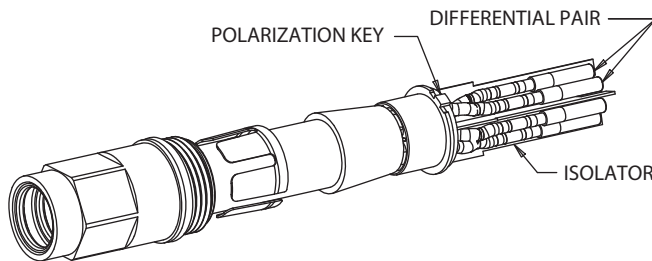

FIGURE 3
SOCKET MODULE PIN-OUT
FROM FRONT

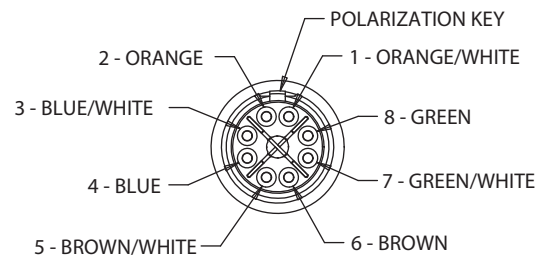
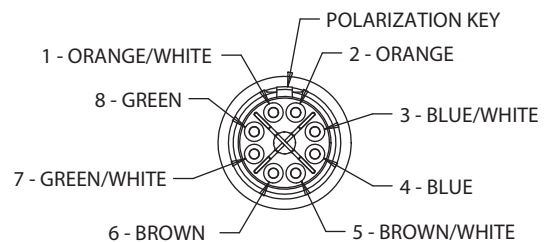

FIGURE 4
PIN MODULE PIN-OUT
FROM FRONT



STEP 4

- A. Push the cable all the way into the isolator so the wire pairs can be spread out easily
- B. Move the wires/contacts out of the way and insert the inner insulator on the isolator. Slide the inner insulator all the way onto the isolator.
- C. Snap each pair into the appropriate position on the inner insulator. Refer to figure 2 for sockets and figure 3 for pins.

Notes:

Be sure to maintain twist of each pair as close to the insulator as possible to improve signal. Do not over twist

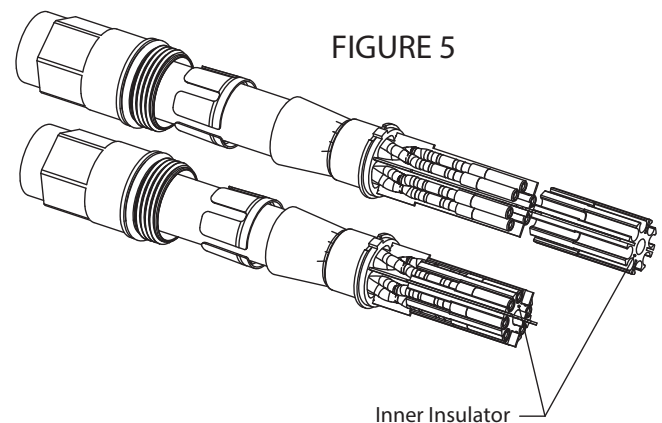

FIGURE 5

SPEEDMASTER Assembly Instructions



AI85082 SpeedMaster™ Contact Module Assembly Instructions

STEP 5

- A. Slide outer insulator onto module assembly. Be sure to align the slots/fins and polarization keys. (Figure 6 and 7)
- B. Fold braid shield forward onto termination zone. (Figure 7)
- C. Slide thread ferrule over shield ferrule and move both to the main shoulder. (Figure 8)
- D. Trim excessive braid to behind main shoulder. (Figure 8)

FIGURE 6

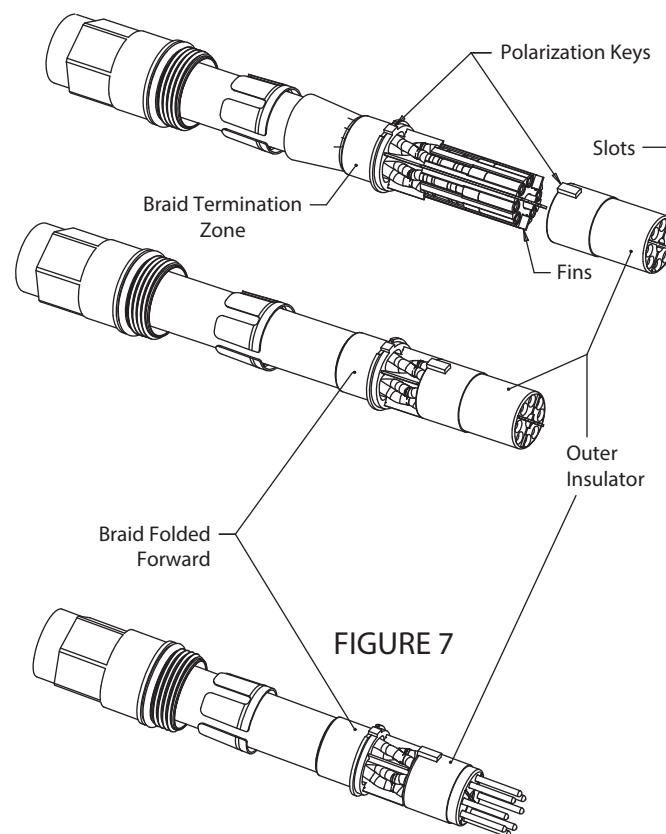

Pin Module (858-101) Shown For Reference

FIGURE 7

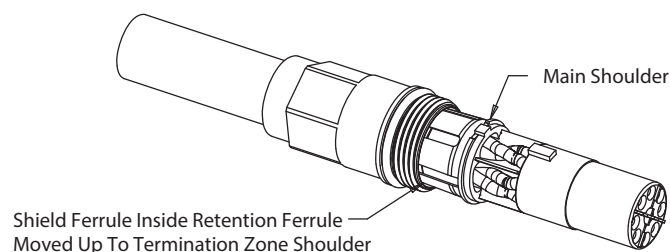
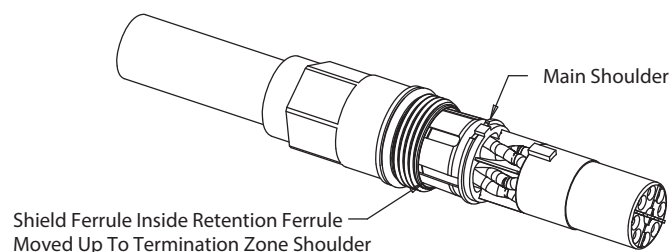

FIGURE 8



SPEEDMASTER Installation Instructions



AI85087 SpeedMaster™ Installation Instructions for Mighty Mouse 824

INSTALLATION

- A. Slide completed module into the insert cavity, making sure to align the module polarization keys with the cavity keyway. (Figure 1)
- B. Using a 9mm wrench or the retention ferrule tool (Glenair P/N 607-011), tighten the outer shield ferrule to a torque of 8-10 in-lb. (Figure 2)
- C. Install 809SL060-3 shrink boot onto rear of shell. (Figure 3)

Notes:

Figures 1-3 show installation into a 824-010-01 shell. Installation in all other Mighty Mouse SpeedMaster connectors is identical.

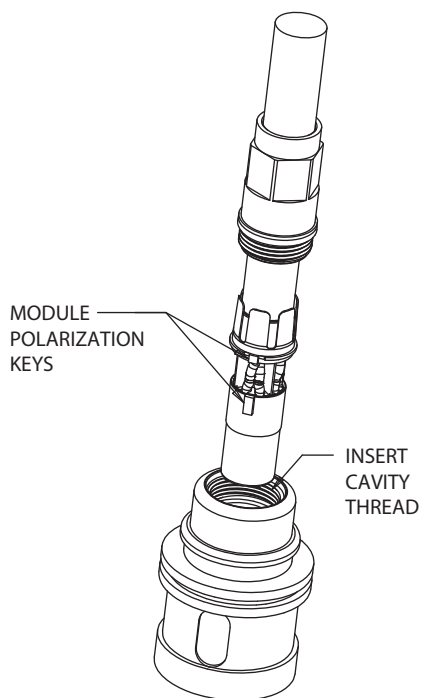

FIGURE 1

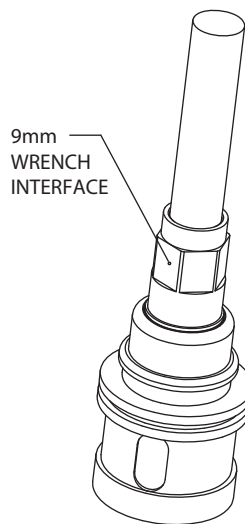

FIGURE 2

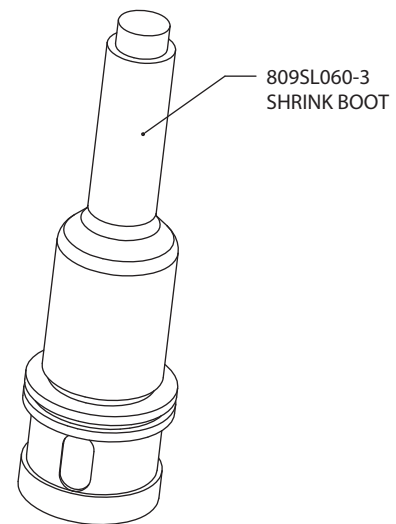

FIGURE 3

SPEEDMASTER Installation Instructions



AI85089 SpeedMaster™ Installation Instructions for HiPer-D

INSTALLATION

- A. Slide completed module into the insert cavity, making sure to align the module polarization keys with the cavity keyway. (Figure 1)
- B. Using the retention ferrule tool (Glenair P/N 607-011), and a 3/8" wrench, tighten the outer shield ferrule to a torque of 8-10 in-lb. (Figure 2)
- C. Install remaining modules in the same manner (figure 3)
- D. Being sure to line up the alignment rib/ribway on each half of the clamshell, fasten the 2 halves together using the four 8-32 x 3/8 socket head cap screws. (Figure 4)

Notes:

Figures 1-4 show installation into a 4 cavity female rear panel mount HiPer-D. Installation is the same for other HiPer-D shell types and arrangements.

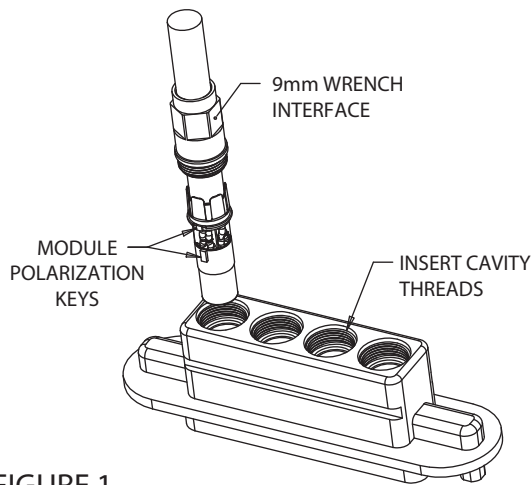

FIGURE 1

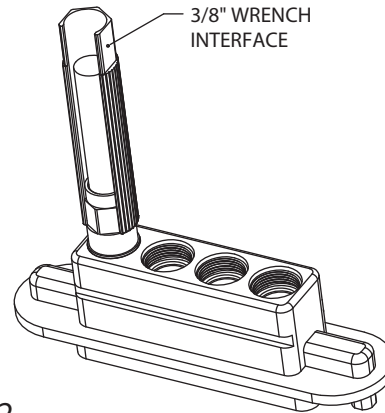

FIGURE 2

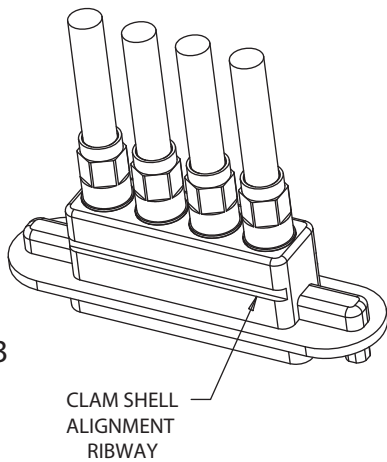

FIGURE 3

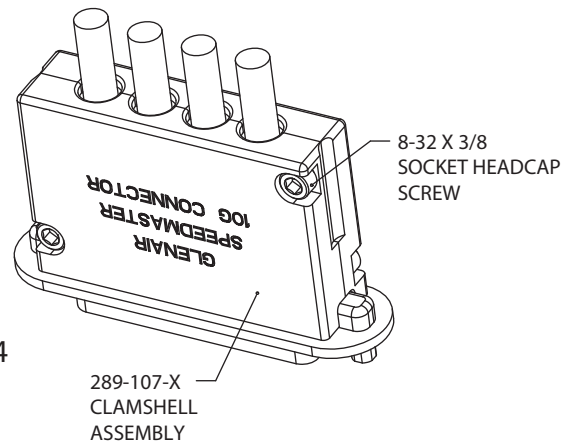

FIGURE 4

SPEEDMASTER Installation Instructions



AI85086 SpeedMaster™ Installation Instructions for SuperNine®

INSTALLATION

- A. Slide completed module into the insert cavity, making sure to align the module polarization keys with the cavity keyway. (Figure 1)
- B. Using the retention ferrule tool (Glenair P/N 607-011), and a 3/8" wrench, tighten the outer shield ferrule to a torque of 8-10 in-lb. (Figure 2)
- C. Install remaining modules in the same manner (figure 3)

Notes:

Figures 1-3 show installation into a SuperNine 25-7 plug. Glenair recommends starting with the center module for arrangement 25-7.

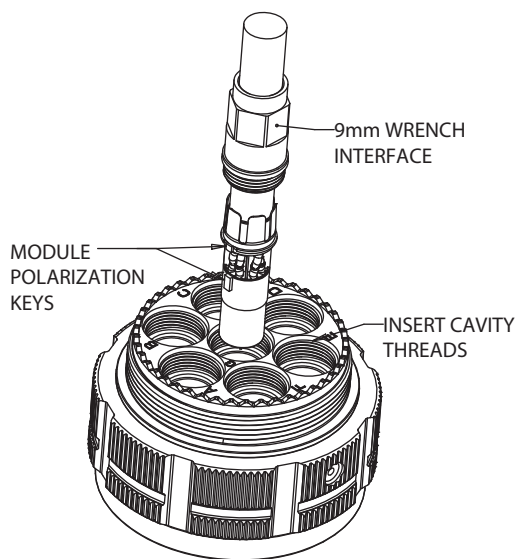

FIGURE 1

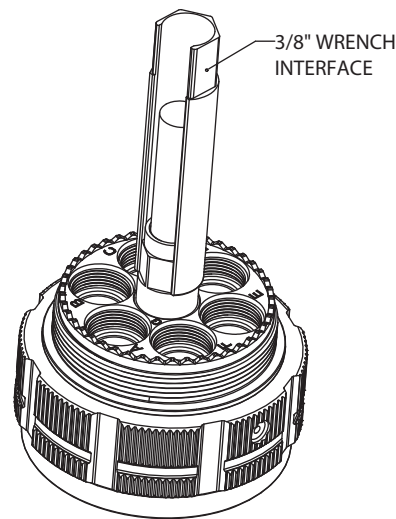

FIGURE 2

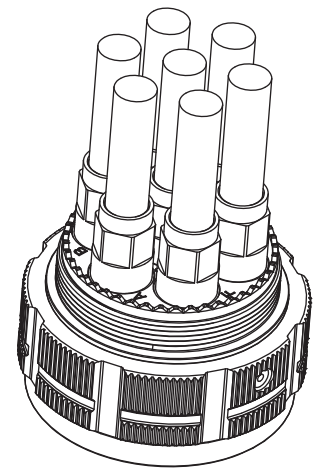



FIGURE 3

ADDITIONAL RUGGEDIZED

HIGH-SPEED DATALINK INTERCONNECTS

contacts · connectors · jumpers



RUGGEDIZED RJ45 AND USB

SUPERSEAL™
CONNECTORS AND ACCESSORIES

1AW: MIL-DTL-38999 • MIL-DTL-5015 • MIL-DTL-26482 • MIL-DTL-28840 • SR, 80 MIGHTY MOUSE



APRIL 2016



SERIES 85
RF, MICROWAVE
AND DATALINK CONTACTS

for MIL-DTL-38999, Series 23 SuperNine®, Series 80 Mighty Mouse, and Series 79 Micro-Crimp® connectors

APRIL 2016



OCTOBYTE
THE FASTER 4/8 POLE INTERCONNECT SYSTEM
FOR ETHERNET DATA APPLICATIONS

APRIL 2016

SUPERSEAL™ IP67 OPEN-FACE RUGGEDIZED FIELD RJ45 SOLUTIONS



MIL-DTL-38999 Sr. III type
SuperSeal™ RJ45



Series 80 Mighty Mouse
SuperSeal™ RJ45



Series IPT 26482 type
SuperSeal™ RJ45



Series ITS 5015 type
SuperSeal™ RJ45



MIL-DTL-28840 type
SuperSeal™ RJ45

SUPERSEAL™ IP67 OPEN-FACE RUGGEDIZED FIELD USB SOLUTIONS



MIL-DTL-38999 Sr. III type
SuperSeal™ USB

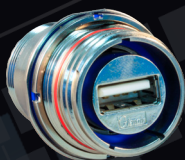

Series 80 Mighty Mouse
SuperSeal™ USB



Series IPT 26482 type
SuperSeal™ USB



Series ITS 5015 type
SuperSeal™ USB



MIL-DTL-28840 type
SuperSeal™ USB

HIGH-SPEED / RF DATALINK CONTACTS



Size #8 differential twinax contacts

Size #12 ultra-twinax differential twinax contacts

Size #8 quadrax contacts

Size #8 spring-loaded BMB microwave contacts

Size #12 SMPM type spring-loaded coaxial

EL OCHITO® OCTAXIAL SIZE #8 CONTACTS FOR GIGABIT AND 10G ETHERNET



El Ochito®: The 10G Ethernet contact with patented data pair isolation technology

#24 / #26 version with integrated removal tool
#26 version

#24 / #26 version
#26 version

Discrete contacts for D38999 Series III type, Mighty Mouse, SuperNine®, and ARINC 600

Prewired contacts with Cat 6A aerospace #24 or #26 gage Ethernet cable

El Ochito® test adapters and test jumpers

GLENAIR CONNECTOR SERIES FOR EL OCHITO® AND OTHER HIGH-SPEED DATALINK CONTACTS

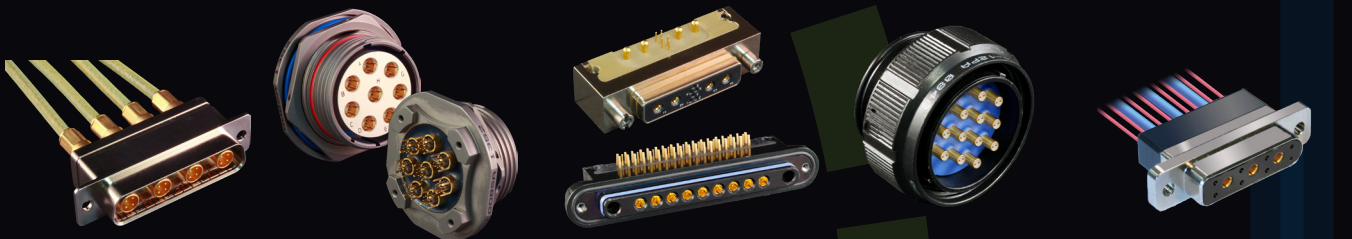

Series 28 HiPer-D® with Quadrax contacts

Series 23 SuperNine® with El Ochito PC tail contacts

Series 79 Micro-Crimp® with coax contacts

Series 80 Mighty Mouse with differential twinax

MWDM Micro-D with coax contacts

OCTOBYTE™ SERIES RUGGEDIZED ETHERNET CONNECTOR

SPEEDMASTER™ 10G ETHERNET

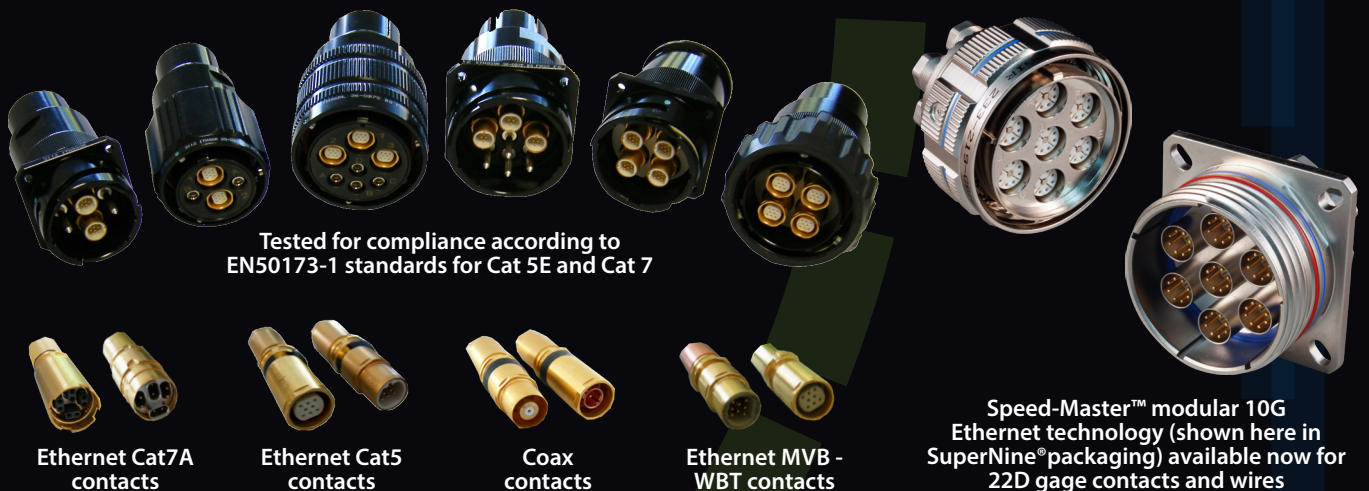

Tested for compliance according to EN50173-1 standards for Cat 5E and Cat 7

Speed-Master™ modular 10G Ethernet technology (shown here in SuperNine® packaging) available now for 22D gage contacts and wires

Ethernet Cat7A contacts

Ethernet Cat5 contacts

Coax contacts

Ethernet MVB - WBT contacts



Out of This World
**INTERCONNECT
SOLUTIONS**

Glenair, Inc.

1211 Air Way • Glendale, California • 91201-2497

Telephone: 818-247-6000 • Fax: 818-500-9912 • sales@glenair.com

www.glenair.com

**Glenair Power
Products Group**

860 N. Main Street Extension
Wallingford, CT
06492

Telephone:
203-741-1115
Facsimile:
203-741-0053
sales@glenair.com

Glenair UK Ltd

40 Lower Oakham Way
Oakham Business Park
P.O. Box 37, Mansfield
Notts, NG18 5BY England

Telephone:
+44-1623-638100
Facsimile:
+44-1623-638111
sales@glenair.co.uk

Glenair Microway Systems

7000 North Lawndale Avenue
Lincolnwood, IL
60712

Telephone:
847-679-8833
Facsimile:
847-679-8849

Glenair Nordic AB

Gustav III : S Boulevard 46
SE-169 27 Solna
Sweden

Telephone:
+46-8-50550000
sales@glenair.se

Glenair Electric GmbH

Schaberweg 28
61348 Bad Homburg
Germany

Telephone:
06172 / 68 16 0
Facsimile:
06172 / 68 16 90
info@glenair.de

Glenair Iberica

C/ La Vega, 16
45612 Velada
Spain

Telephone:
+34-925-89-29-88
Facsimile:
+34-925-89-29-87
sales@glenair.es

Glenair Italia S.p.A.

Via Del Lavoro, 7
40057 Quarto Inferiore –
Granarolo dell'Emilia
Bologna, Italy

Telephone:
+39-051-782811
Facsimile:
+39-051-782259
info@glenair.it

Glenair France SARL

7, Avenue Parmentier
Immeuble Central Parc #2
31200 Toulouse
France

Telephone:
+33-5-34-40-97-40
Facsimile:
+33-5-61-47-86-10
sales@glenair.fr

Glenair Korea

B-1304 Gunpo IT Valley
148 Gosan-Ro, Gunpo-Si
Kyunggi-Do, Korea
435-733

Telephone:
+82-31-8068-1090
Facsimile:
+82-31-8068-1092
sales@glenair.kr

