

SERIES 240

EMI/EMP Filter Connectors

FOR MIL-DTL-38999 AND OTHER MIL-AERO INTERCONNECTION SYSTEMS

OCTOBER 2013

SERIES 240

EMI/EMP Filter Connectors

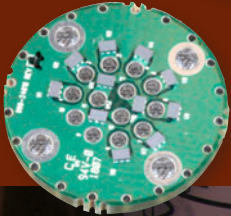

High reliability EMI/EMP filter connectors resolve even the most difficult EMC challenges



Glenair is unique in the high-reliability mil-aero filter connector business. We are the only supplier of both build-to-spec as well as standard catalog filter connector solutions for the complete range of currently specified military aerospace circular and rectangular connectors. We maintain a 100% vertically integrated manufacturing facility for every aspect of EMI/EMP filter connector fabrication including in-house fabrication of multilayer ceramic planar arrays. As a result, we offer the fastest turnaround in our industry on both build-to-spec and standard catalog solutions. Our capabilities include:

- Planar, multilayer ceramic capacitive filters, with and without transient voltage suppression diodes
- C, L-C, C-L and Pi filter electrical configurations
- PC tail, solder cup or crimp-contact termination
- 10 to 1,000,000 pF capacitance
- Special high operating temperature solutions



Glenair, Inc.
1211 Air Way
Glendale, CA
91201-2497
818-247-6000
sales@glenair.com
www.glenair.com

**Series 240
EMI/EMP Filter Connectors
Table of Contents**

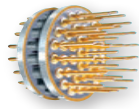

Introduction to Glenair Series 240 EMI/EMP Filter Connectors

A



Military Standard Type Circular Filter Connectors

B



Series 80 Mighty Mouse Filter Connectors

C

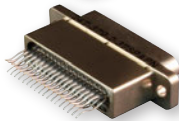

MIL-DTL-83516 Type Micro-D Filter Connectors

D



MIL-DTL-24308 Type D-Subminiature and HiPer-D Filter Connectors

E

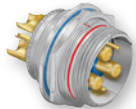

Series 970 PowerTrip Filter Connectors

F



Series 79 Micro-Crimp Filter Connectors

G



ARINC Filter Connectors

H



TVS Filter Connectors

J



Testing Accessories

K



Conductive Gaskets And Accessories

L



Appendix and Part Number Index

Introduction to Filter Connectors • Application Checklist • Compliance Matrix for MIL-DTL-38999 Series III Filter Connectors • Part Number Index

Appendix

Dimensions in inches (millimeters) and are subject to change without notice.



SERIES 240

EMI/EMP Filter Connectors

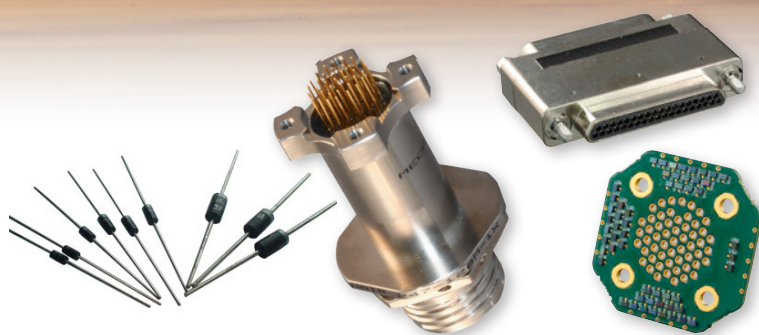

Glenair manufactures a full range of filter connectors for use in EMC/EMP management of electronic systems and interconnect cabling. All connectors are designed in accordance with applicable connector specifications, and are designed to mate with plugs with the same insert configuration and opposite contact gender. Planar filter arrays and TVS diodes may be integrated into both standard catalog as well as build-to-order configurations. Glenair's state-of-the-art diode burn-in process tests leaded and surface mount diodes with leakage current monitored throughout the entire test procedure ensuring field reliability.

Table I: Capacitor Array Code / Capacitance Range

Class	Pi - Circuit (pF)	C - Circuit (pF)
X	160,000 - 240,000	80,000 - 120,000
Y	80,000 - 120,000	40,000 - 60,000
Z	60,000 - 90,000	30,000 - 45,000
A	38,000 - 56,000	19,000 - 28,000
B	32,000 - 45,000	16,000 - 22,500
C	18,000 - 33,000	9,000 - 16,500
D	8,000 - 12,000	4,000 - 6,000
E	3,300 - 5,000	1,650 - 2,500
F	800 - 1,300	400 - 650
G	400 - 600	200 - 300
J	70-120	35-60



ARINC 600 size 2 filter connector. Glenair also manufactures narrow-profile size 1 and double-wide size 3. All configurations are environmentally sealed for rugged airframe applications.

- **Planar, multilayer ceramic capacitive filters, with and without transient voltage suppression diodes**
- **C and Pi electrical configurations**
- **PC tail or solder cup wire termination**
- **35 – 240,000 pF capacitance**
- **Fast and reliable diode burn-in and test services**
- **Turnkey in-house manufacturing of all filter connector elements and processes**

SERIES 240 EMI/EMP Filter connectors

Fast, reliable in-house manufacturing



Unique and Special Purpose EMI/EMP Filter Connectors

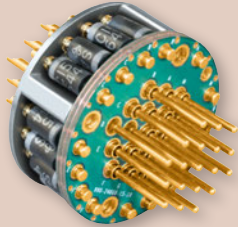

EMI Filter Package with TVS EMP Diodes



Unique Filter Package with Sidecar Filter Elements

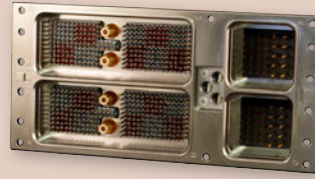

ARINC Rack and Panel Filter Connector

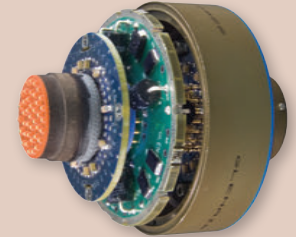

EMP Diode-Equipped Connector with Oversized Shell

Performance Ratings

Shock and Vibration	IAW MIL-DTL-38999
Thermal Shock	-55° C to +125° C per EIA-364-32; 380 cycles
Operating Temperature	-55° C to +125° C
Mating Cycles	500 Mating Cycles
Corrosion Resistance	1000 Hours on Stainless Steel Shells
Shielding Effectiveness	Effective over a range of 100MHz to 10GHz with a minimum 50dB effectiveness at 10GHz
Immersion Rating	MIL-STD-810 Method 512; 1 Meter for 1 Hr. (selected series)
Shell-to-Shell Resistance	2.5 Millivolt drop maximum, per EIA-364-83

Electrical Performance

Current Rating	up to 220 Amps
Capacitance	10pF to 1,000,000pF
Insulation Resistance	5GΩ
Dielectric Withstanding Voltage	100 to 2500 VDC
Dissipation Factor	2.5% Max
Diode Clamping Voltage Range	3.3V to 260V
Diode Peak/Pulse Power	up to 30KW

The Industry's Most Comprehensive and Compliant Filter Service

Connector Series:

38999	83513
Series I, II, III, IV	5015
26482	Sr. 80 Mighty Mouse
83723	Sr. 79 Micro-Crimp
28840	Sr. ITS Reverse-Bayonet
24308	Sr. 28 HiPer-D
ARINC 600	Sr. 970 PowerTrip

Line Types:

CAN BUS	TTL
ARINC 429	Analog Sensors
RS 232	Thermocouple Wires
RS 422	USB
RS 485	Ethernet

Requirement Compliance:

MIL-STD-449D: RF Spectrum
MIL-STD-461E: EMI Susceptibility
MIL-STD-1310G: Shipboard EMC
MIL-STD-1512: Electroexplosive Subsystems
MIL-STD-1541A: EMC for Space Systems
MIL-STD-1795A: Aerospace Lightning Protection
MIL-STD-1857: Grounding, Bonding and Shielding
MIL-STD-1542B: EMC and Grounding for Space Systems
EN 61000-4-2, 3, 4, 5, 6, 8: EM, RF and Power
RTCA/DO-160 Sec 22: Pin/Cable Level and Waveform

Filter Module Elements

Multilayer Ceramic Planar Array: Containing a network of capacitors, feedthrus and ground lines.

Inductors: Ferrite Beads to provide inductance and increase insertion loss

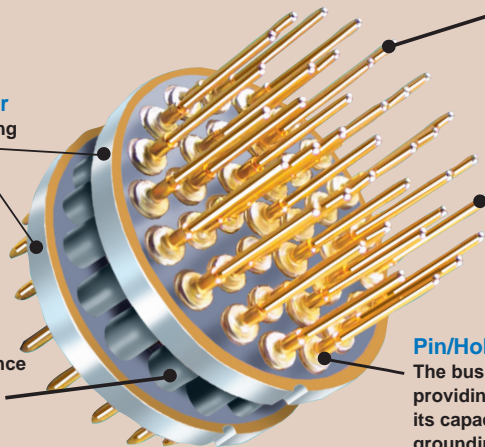

Contact Types: Choose from Solder Cup, PC Tail or Piggy-Back Crimp (Consult Factory for PC Tail Length Options).

Contact Material: Gold Plated Copper Alloy.

Pin/Hole Intersection: The business-end of the filter, providing each contact with its capacitance value and grounding.

Filter Types

C Single capacitor with low self inductance
LC, CL Single capacitor combined with an inductive element
Pi Dual capacitors with a single inductive element positioned between.

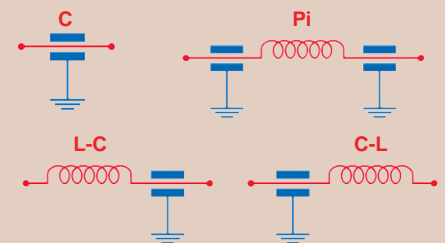

SERIES 240

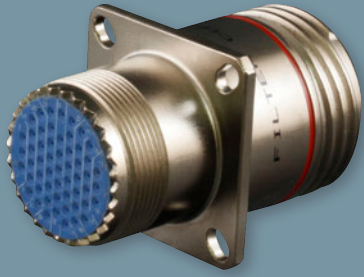

MS Type Circular Filter Connectors

The industry's best short lead-time source for planar array type EMI/EMP filter connectors



Glenair's family of circular military standard type EMI/EMP filter connectors is designed to meet stringent military/aerospace performance requirements. Each connector series is offered with standard low-pass Pi or C filter arrays, or with customized filters to meet specific frequency and capacitance requirements. Thermally conductive epoxy protects the filter package from mechanical and heat stress and also provides a waterproof seal. All filtered receptacles are interchangeable with standard plugs and connector savers, and each respective series of connectors is supplied with a range of shell styles in both environmental and hermetic configurations.

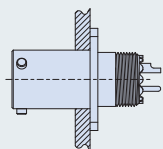
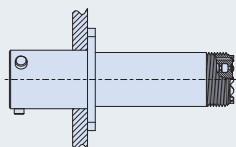
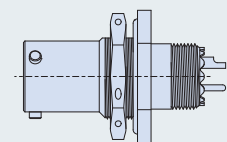
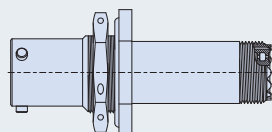
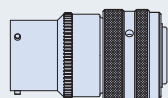

Glenair, Inc.
1211 Air Way
Glendale, CA
91201-2497
818-247-6000
sales@glenair.com
www.glenair.com

**240-381W****Wall Mount Receptacles****Page
B-6****240-381R****Wall Mount Receptacles
with Crimp Removable Contacts****Page
B-8****240-381J****Jam Nut Receptacles****Page
B-10****240-381S****Jam Nut Receptacles
with Crimp Removable Contacts****Page
B-12****240-381A****Connector Adapters****Page
B-14**

Notes

1. Materials/Finishes: Shells, Barrel, Coupling Nut, Jam Nut - See Table I
Insulators - High grade rigid dielectric/N.A.
Seals - Fluorosilicone
Contacts: Copper alloy 50 μ " Gold over 50 μ " Nickel
2. Assembly to be identified with Glenair's name, part number, and date code - space permitting.
3. Insert Arrangement in accordance with MIL-STD-1560. (Arrangement shown for reference only)
4. EMI Circular Filter Receptacle connectors designed to meet requirements of MIL-STD-2120 and MIL-DTL-38999, Series I.
5. All contacts to have identical filter value. Other filter arrangements available, contact factory.
6. Electrical Ratings: DWV- 500 VDC; Standard Operating Voltage 200 VDC (Filter class X, Y and Z are 250 VDC)
7. Insulation Resistance: 5000 MegOhms at 200 VDC for classes A, B, C, D, E, F, G, J. 1000 MegOhms at 83 VDC for classes X, Y, Z
8. Operating Temperature: -55°C to +125°C (Env Class Connectors)
9. Other filter styles (C-L, L-C, Unbalanced Pi, Multi-Stage, Multi-Value) are available, please consult the factory.

Dimensions in inches (millimeters) and are subject to change without notice.

MIL-DTL-38999 Series I Type Filter Connectors Panel Cut-Outs



MIL-DTL-38999
Type

B

Back Panel Mounting

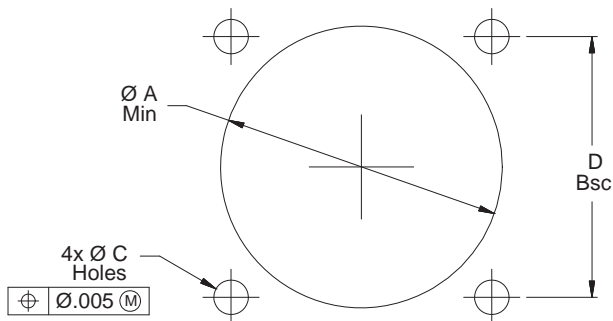

Front Panel Mounting

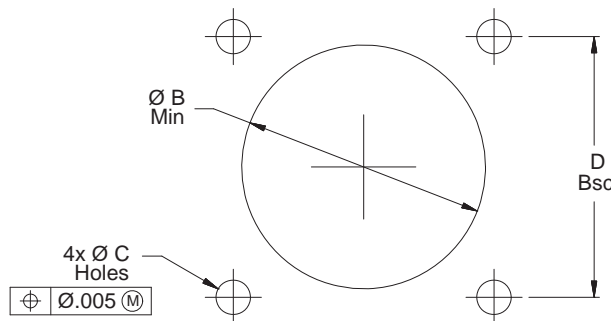

MIL-DTL-38999 Series I Square Flange Panel Cut-Outs				
Shell Size	Ø A Min Back Panel	Ø B Min* Front Panel	Ø C Holes	D Bsc
9	.656 (16.7)	.625 (15.9)	.133 (3.4) .123 (3.1)	.719 (18.3)
11	.796 (20.2)	.750 (19.1)		.812 (20.6)
13	.922 (23.4)	.906 (23.0)		.906 (23.0)
15	1.047 (26.6)	1.016 (25.8)		.969 (24.6)
17	1.219 (31.0)	1.141 (29.0)		1.062 (27.0)
19	1.297 (32.9)	1.141 (29.0)		1.156 (29.4)
21	1.422 (36.1)	1.266 (32.2)		1.250 (31.8)
23	1.547 (39.3)	1.375 (34.9)	.159 (4.0) .149 (3.8)	1.375 (34.9)
25	1.672 (42.5)	1.484 (37.7)	.155 (3.9) .145 (3.7)	1.500 (38.1)

*Note: Accessory threads for shell size 9 thru 17 are one size larger than MIL-DTL-38999 Series I to accommodate filters. Recommended front panel cut-outs (Ø B) modified accordingly.

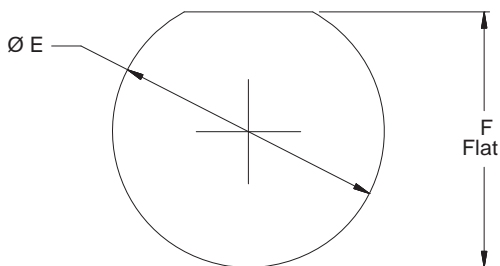

MIL-DTL-38999 Series I Jam Nut Panel Cut-Out		
Shell Size	Ø E	F Flat
9	.710 (18.0)	.670 (17.0)
	.700 (17.8)	.660 (16.8)
11	.835 (21.2)	.771 (19.6)
	.825 (21.0)	.761 (19.3)
13	1.020 (25.9)	.955 (24.3)
	1.010 (25.7)	.945 (24.0)
15	1.145 (29.1)	1.085 (27.6)
	1.135 (28.8)	1.075 (27.3)
17	1.270 (32.3)	1.210 (30.7)
	1.260 (32.0)	1.200 (30.5)
19	1.395 (35.4)	1.335 (33.9)
	1.385 (35.2)	1.325 (33.7)
21	1.520 (38.6)	1.460 (37.1)
	1.510 (38.4)	1.450 (36.8)
23	1.645 (41.8)	1.585 (40.3)
	1.635 (41.5)	1.575 (40.0)
25	1.770 (45.0)	1.710 (43.4)
	1.760 (44.7)	1.700 (43.2)

Dimensions in inches (millimeters) and are subject to change without notice.



MIL-STD-1560 Insert Arrangements (Pin Front View) and Shell Polarization for MIL-DTL-38999 Series I Type Filter Connectors

B

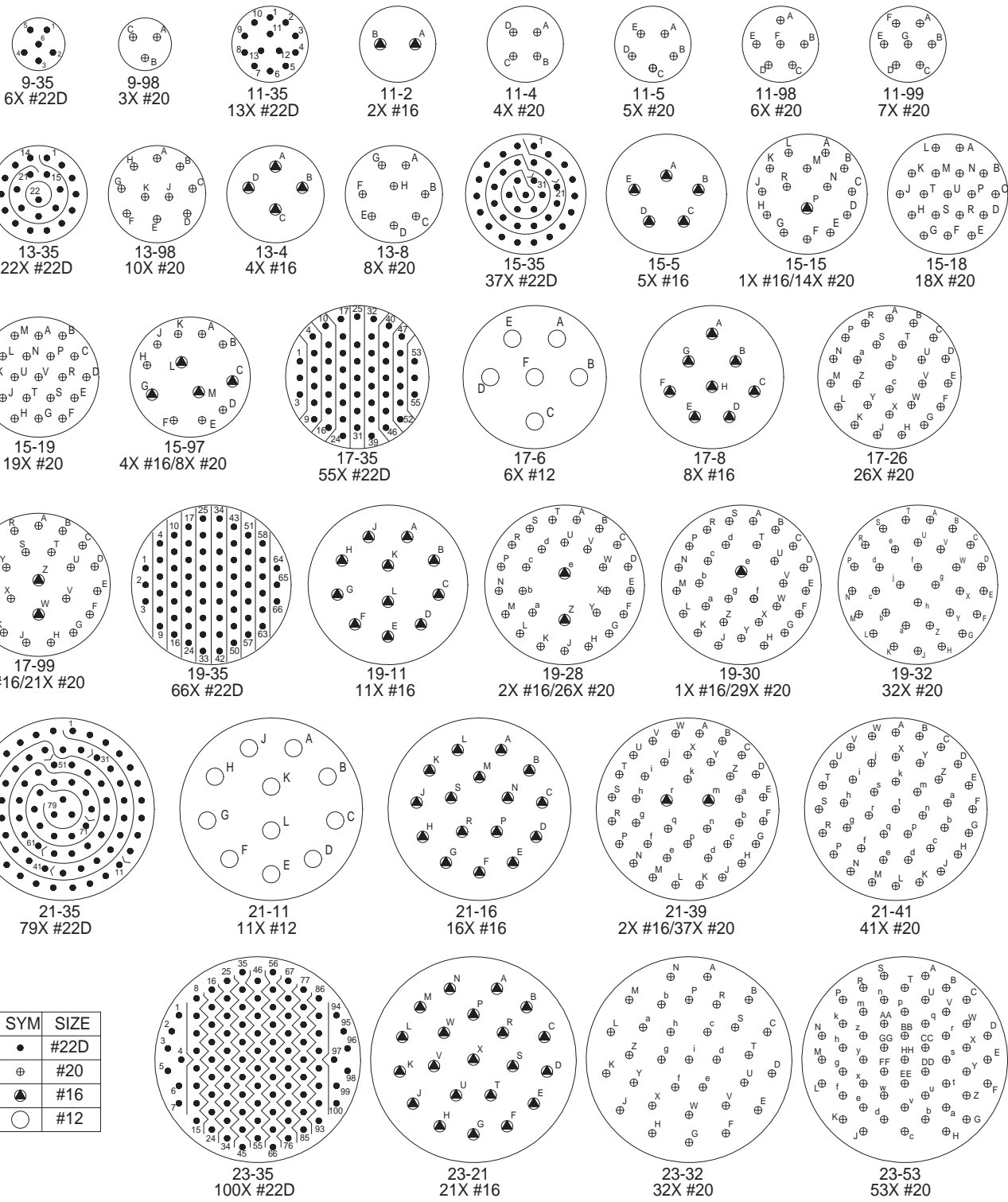

SYM	SIZE
●	#22D
⊕	#20
▲	#16
○	#12

Dimensions in inches (millimeters) and are subject to change without notice.

MIL-STD-1560 Insert Arrangements (Pin Front View) and Shell Polarization for MIL-DTL-38999 Series I Type Filter Connectors



MIL-DTL-38999
Type

B

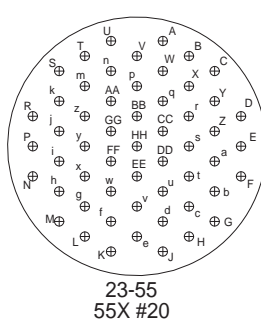

23-55
55X #20

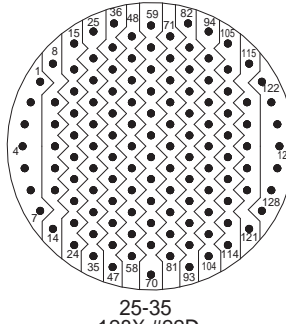

25-35
128X #22D

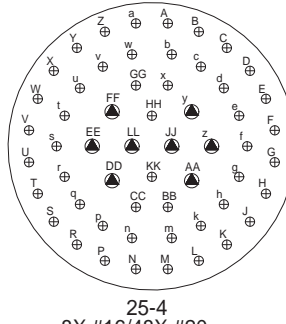

25-4
8X #16/48X #20

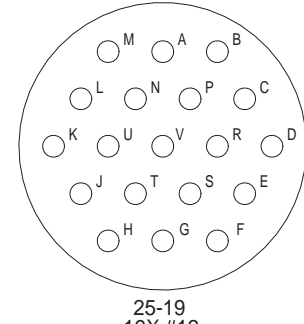

25-19
19X #12

SYM	SIZE
●	#22D
⊕	#20
⊗	#16
○	#12

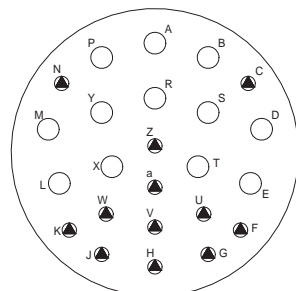

25-24
12X #12/12X #16

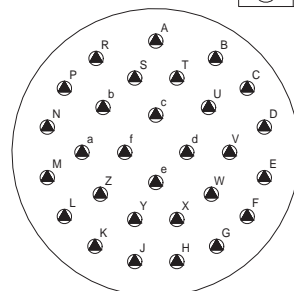

25-29
29X #16

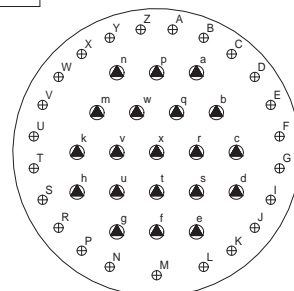

25-43
20X #16/23X #20

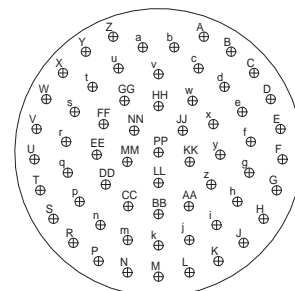

25-61
61X #20

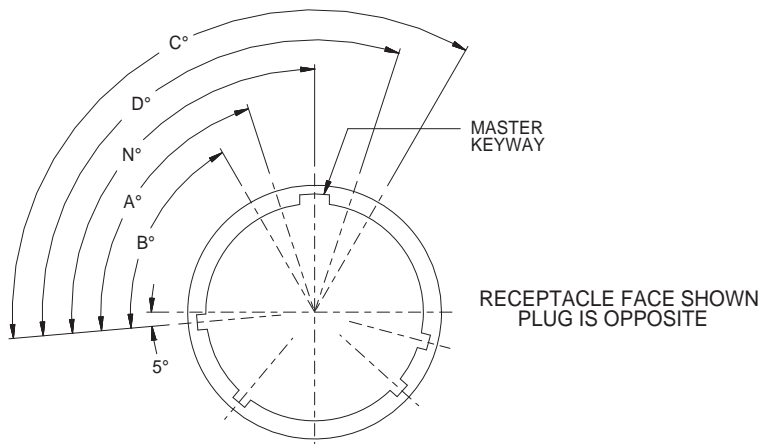

NOTE: MASTER KEY & KEYWAY HAS VARIOUS POSITIONS WHILE MINOR KEYS AND KEYWAYS REMAIN FIXED.

MIL-DTL-38999 Series I Keying Positions					
Shell Size	N° Bsc	A° Bsc	B° Bsc	C° Bsc	D° Bsc
9	95°	77°	-	-	113°
11	95°	81°	67°	123°	109°
13	95°	75°	63°	127°	115°
15	95°	74°	61°	129°	116°
17	95°	77°	65°	125°	113°
19	95°	77°	65°	125°	113°
21	95°	77°	65°	125°	113°
23	95°	80°	69°	121°	110°
25	95°	80°	69°	121°	110°

Dimensions in inches (millimeters) and are subject to change without notice.

© 2013 Glenair, Inc.

U.S. CAGE Code 06324

Printed in U.S.A.

D38999 SERIES I TYPE WALL MOUNT RECEPTACLE

How To Order										
Sample Part Number	240-381	W	ME	15-35	P	S	P	A	C	N
Filter Connector	MIL-DTL-38999 Series I Type									
Shell Style	W = Wall Mount									
Connector Class	See Table I									
Insert Arrangement	IAW MIL-STD-1560. (See pages B-4 – B-5)									
Contact Gender	P = Pin S = Socket									
Termination	S = Solder Cup P = PC Tail									
Filter Type	P = Pi Circuit C = C Circuit (See Note 2)									
Capacitance	See Table II									
Flange Mounting Style	H = Round Holes C = Clinch Nuts (4-40 UNC) M = Metric Clinch Nuts (M3)									
Alternate Key Position	A, B, C, D, N = Normal (See page B-5)									

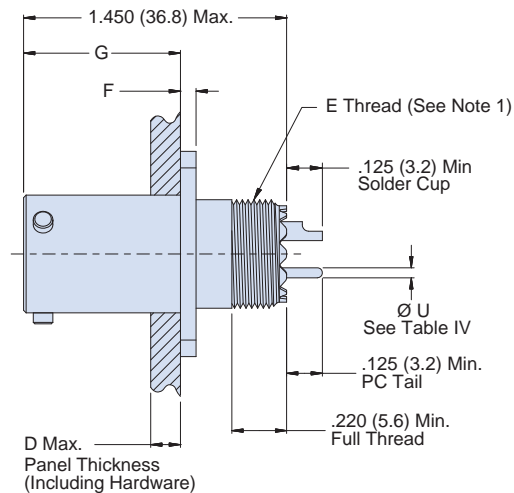
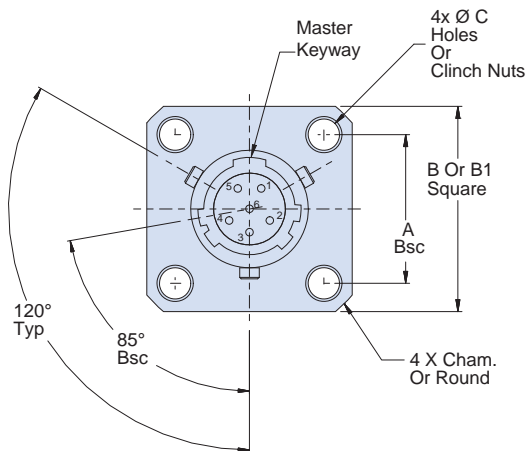

Notes

1. "E" accessory threads for shell size 9 thru 17 are one size larger than MIL-DTL-38999 Series I to accommodate filters
2. Other filter styles (C-L, L-C, Unbalanced Pi, Multi-Stage, Multi-Value) are available, please consult the factory.

Dimensions in inches (millimeters) and are subject to change without notice.

240-381W
MIL-DTL-38999 Series I Type Filter Connector
Wall Mount Receptacle



MIL-DTL-38999
Type

B

Sym	Class	Material	Finish Description
ME	Environmental	Aluminum	Electroless Nickel
MT	Environmental	Aluminum	Ni-PTFE 1000 Hour Grey™ Nickel Fluorocarbon Polymer
NF	Environmental	Aluminum	Cadmium O.D. Over Electroless Nickel
ZL	Environmental	Stainless Steel	Electro-Deposited Nickel
ZN	Environmental	Aluminum	Zinc-Nickel, Olive Drab
ZR	Environmental	Aluminum	Zinc Nickel, Black - RoHS
H2*	Hermetic	Stainless Steel	Electro-Deposited Nickel

*Some dimensions do not apply. See drawing 240-381WH2

Class	Pi - Circuit (pF)	C - Circuit (pF)
X*	160,000 - 240,000	80,000 - 120,000
Y*	80,000 - 120,000	40,000 - 60,000
Z*	60,000 - 90,000	30,000 - 45,000
A	38,000 - 56,000	19,000 - 28,000
B	32,000 - 45,000	16,000 - 22,500
C	18,000 - 33,000	9,000 - 16,500
D	8,000 - 12,000	4,000 - 6,000
E	3,300 - 5,000	1,650 - 2,500
F	800 - 1,300	400 - 650
G	400 - 600	200 - 300
J	70-120	35-60

* Filter Classes X, Y and Z are 250 VDC.
All others are 500 VDC

Contact Size	Ø U
22D	.021 (0.53)
	.018 (0.46)
20	.031 (0.79)
	.029 (0.74)
16	.042 (1.07)
	.038 (0.97)
12	.096 (2.44)
	.092 (2.34)

Shell Size	A Bsc	Thru Hole Flange		Clinch Nut Flange	D Max	E Thread UNEF-2A	F +.015 (.38) -.000 (.00)	G +.000 (.00) -.005 (.13)
		B Sq. ±.020 (.51)	Ø C +.010 (.25) -.005 (.13)	B1 Sq. ±.020 (.51)				
9	.719 (18.3)	.938 (23.8)	.128 (3.3)	1.019 (25.9)	.234 (5.9)	.5625-24	.085 (2.2)	.820 (20.8)
11	.812 (20.6)	1.031 (26.2)	.128 (3.3)	1.112 (28.2)	.234 (5.9)	.6875-24	.085 (2.2)	.820 (20.8)
13	.906 (23.0)	1.125 (28.6)	.128 (3.3)	1.206 (30.6)	.234 (5.9)	.8125-20	.085 (2.2)	.820 (20.8)
15	.969 (24.6)	1.219 (31.0)	.128 (3.3)	1.269 (32.2)	.234 (5.9)	.9375-20	.085 (2.2)	.820 (20.8)
17	1.062 (27.0)	1.312 (33.3)	.128 (3.3)	1.362 (34.6)	.234 (5.9)	1.0625-18	.085 (2.2)	.820 (20.8)
19	1.156 (29.4)	1.438 (36.5)	.128 (3.3)	1.456 (37.0)	.234 (5.9)	1.0625-18	.085 (2.2)	.820 (20.8)
21	1.250 (31.8)	1.562 (39.7)	.128 (3.3)	1.562 (39.7)	.204 (5.2)	1.1875-18	.115 (2.9)	.790 (20.1)
23	1.375 (34.9)	1.688 (42.9)	.147 (3.7)	1.719 (43.7)	.204 (5.2)	1.3125-18	.115 (2.9)	.790 (20.1)
25	1.500 (38.1)	1.812 (46.0)	.147 (3.7)	1.844 (46.8)	.193 (4.9)	1.4375-18	.115 (2.9)	.790 (20.1)

Dimensions in inches (millimeters) and are subject to change without notice.

D38999 SERIES I TYPE WALL MOUNT RECEPTACLE WITH CRIMP REMOVABLE CONTACTS

How To Order										
Sample Part Number	240-381	R	ME	15-35	P	C	P	A	C	N
Filter Connector	MIL-DTL-38999 Series I Type									
Shell Style	R = Wall Mount Receptacle with Crimp Contacts									
Connector Class	See Table I									
Insert Arrangement	IAW MIL-STD-1560. (See pages B-4 – B-5)									
Contact Gender	P = Pin S = Socket									
Termination	C = Crimp									
Filter Type	P = Pi Circuit C = C Circuit (See Note 3)									
Capacitance	See Table II									
Flange Mounting Style	H = Round Holes C = Clinch Nuts (4-40 UNC) M = Metric Clinch Nuts (M3)									
Alternate Key Position	A, B, C, D, N = Normal (See page B-5)									

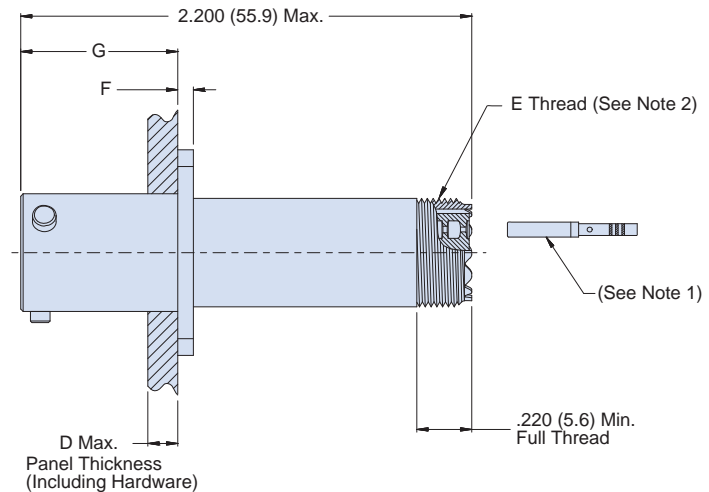
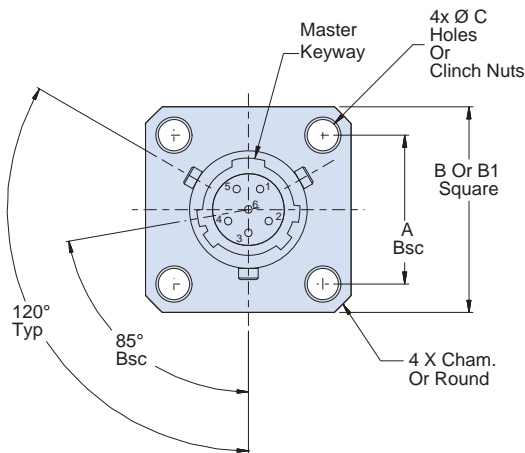

Notes

1. Crimp removable contacts to conform to MIL-C-39029/57-358, Size 16, MIL-C-39029/57-357 Size 20, and MIL-C-39029/57-354 Size 22D (Supplied loose).
2. "E" accessory threads for shell size 9 thru 17 are one size larger than MIL-DTL-38999 Series I to accommodate filters
3. Other filter styles (C-L, L-C, Unbalanced Pi, Multi-Stage, Multi-Value) are available, please consult the factory.

Dimensions in inches (millimeters) and are subject to change without notice.

240-381R
MIL-DTL-38999 Series I Type Filter Connector
Wall Mount Receptacle with Crimp Removable Contacts



MIL-DTL-38999
Type

B

Sym	Class	Material	Finish Description
ME	Environmental	Aluminum	Electroless Nickel
MT	Environmental	Aluminum	Ni-PTFE 1000 Hour Grey™ Nickel Fluorocarbon Polymer
NF	Environmental	Aluminum	Cadmium O.D. Over Electroless Nickel
ZL	Environmental	Stainless Steel	Electro-Deposited Nickel
ZN	Environmental	Aluminum	Zinc-Nickel, Olive Drab
ZR	Environmental	Aluminum	Zinc Nickel, Black - RoHS
H2*	Hermetic	Stainless Steel	Electro-Deposited Nickel

*Some dimensions do not apply. See drawing 240-381RH2

Class	Pi - Circuit (pF)	C - Circuit (pF)
X*	160,000 - 240,000	80,000 - 120,000
Y*	80,000 - 120,000	40,000 - 60,000
Z*	60,000 - 90,000	30,000 - 45,000
A	38,000 - 56,000	19,000 - 28,000
B	32,000 - 45,000	16,000 - 22,500
C	18,000 - 33,000	9,000 - 16,500
D	8,000 - 12,000	4,000 - 6,000
E	3,300 - 5,000	1,650 - 2,500
F	800 - 1,300	400 - 650
G	400 - 600	200 - 300
J	70-120	35-60

* Filter Classes X, Y and Z are 250 VDC.
All others are 500 VDC

Shell Size	A Bsc	Thru Hole Flange		Clinch Nut Flange	D Max	E Thread UNEF-2A	F +.015 (.38) -.000 (.00)	G +.000 (.00) -.005 (.13)
		B Sq. ±.020 (.51)	Ø C +.010 (.25) -.005 (.13)	B1 Sq. ±.020 (.51)				
9	.719 (18.3)	.938 (23.8)	.128 (3.3)	1.019 (25.9)	.234 (5.9)	.5625-24	.085 (2.2)	.820 (20.8)
11	.812 (20.6)	1.031 (26.2)	.128 (3.3)	1.112 (28.2)	.234 (5.9)	.6875-24	.085 (2.2)	.820 (20.8)
13	.906 (23.0)	1.125 (28.6)	.128 (3.3)	1.206 (30.6)	.234 (5.9)	.8125-20	.085 (2.2)	.820 (20.8)
15	.969 (24.6)	1.219 (31.0)	.128 (3.3)	1.269 (32.2)	.234 (5.9)	.9375-20	.085 (2.2)	.820 (20.8)
17	1.062 (27.0)	1.312 (33.3)	.128 (3.3)	1.362 (34.6)	.234 (5.9)	1.0625-18	.085 (2.2)	.820 (20.8)
19	1.156 (29.4)	1.438 (36.5)	.128 (3.3)	1.456 (37.0)	.234 (5.9)	1.0625-18	.085 (2.2)	.820 (20.8)
21	1.250 (31.8)	1.562 (39.7)	.128 (3.3)	1.562 (39.7)	.204 (5.2)	1.1875-18	.115 (2.9)	.790 (20.1)
23	1.375 (34.9)	1.688 (42.9)	.147 (3.7)	1.719 (43.7)	.204 (5.2)	1.3125-18	.115 (2.9)	.790 (20.1)
25	1.500 (38.1)	1.812 (46.0)	.147 (3.7)	1.844 (46.8)	.193 (4.9)	1.4375-18	.115 (2.9)	.790 (20.1)

Dimensions in inches (millimeters) and are subject to change without notice.

D38999 SERIES I TYPE JAM NUT RECEPTACLE

How To Order										
Sample Part Number	240-381	J	ME	15-35	P	S	P	A	N	N
Filter Connector	MIL-DTL-38999 Series I Type									
Shell Style	J = Jam Nut									
Connector Class	See Table I									
Insert Arrangement	IAW MIL-STD-1560. (See pages B-4 – B-5)									
Contact Gender	P = Pin S = Socket									
Termination	S = Solder Cup P = PC Tail									
Filter Type	P = Pi Circuit C = C Circuit (See Note 2)									
Capacitance	See Table II									
Flange Mounting Style	N = Not Applicable									
Alternate Key Position	A, B, C, D, N = Normal (See page B-5)									

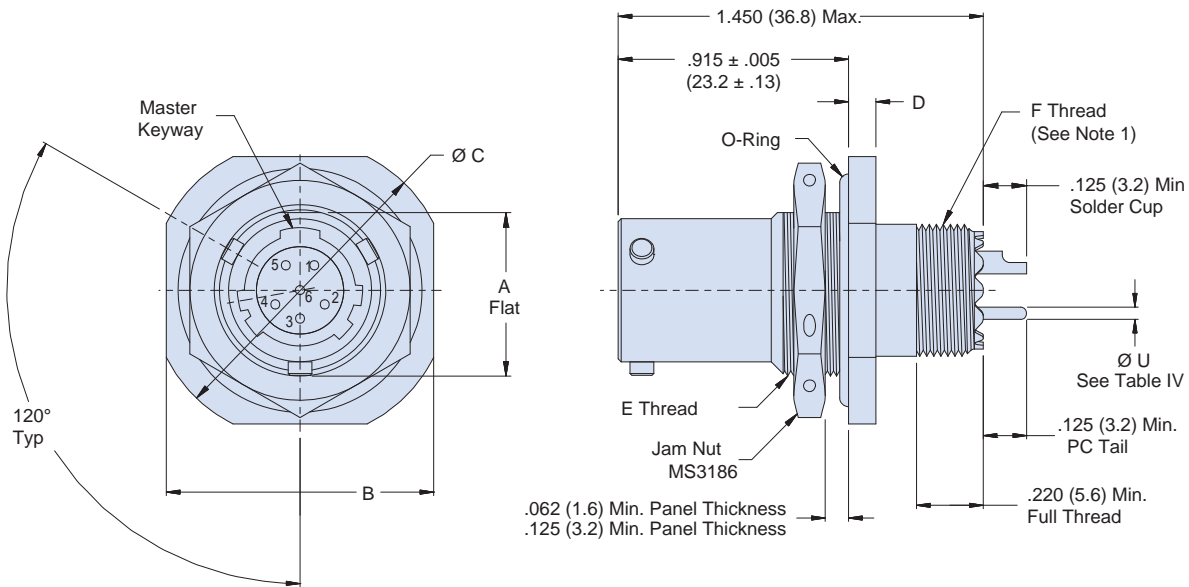

Note

1. "F" accessory threads for shell size 9 thru 17 are one size larger than MIL-DTL-38999 Series I to accommodate filters
2. Other filter styles (C-L, L-C, Unbalanced Pi, Multi-Stage, Multi-Value) are available, please consult the factory.

Dimensions in inches (millimeters) and are subject to change without notice.

240-381J
MIL-DTL-38999 Series I Type Filter Connector
Jam Nut Receptacle



MIL-DTL-38999
Type

B

Table I: Connector Class			
Sym	Class	Material	Finish Description
ME	Environmental	Aluminum	Electroless Nickel
MT	Environmental	Aluminum	Ni-PTFE 1000 Hour Grey™ Nickel Fluorocarbon Polymer
NF	Environmental	Aluminum	Cadmium O.D. Over Electroless Nickel
ZL	Environmental	Stainless Steel	Electro-Deposited Nickel
ZN	Environmental	Aluminum	Zinc-Nickel, Olive Drab
ZR	Environmental	Aluminum	Zinc Nickel, Black - RoHS
H2*	Hermetic	Stainless Steel	Electro-Deposited Nickel

*Some dimensions do not apply. See drawing 240-381JH2

Table II: Capacitor Array Code Capacitance Range		
Class	Pi - Circuit (pF)	C - Circuit (pF)
X*	160,000 - 240,000	80,000 - 120,000
Y*	80,000 - 120,000	40,000 - 60,000
Z*	60,000 - 90,000	30,000 - 45,000
A	38,000 - 56,000	19,000 - 28,000
B	32,000 - 45,000	16,000 - 22,500
C	18,000 - 33,000	9,000 - 16,500
D	8,000 - 12,000	4,000 - 6,000
E	3,300 - 5,000	1,650 - 2,500
F	800 - 1,300	400 - 650
G	400 - 600	200 - 300
J	70-120	35-60

* Filter Classes X, Y and Z are 250 VDC.
 All others are 500 VDC

Table IV: PC Tail Dia	
Contact Size	Ø U
22D	.021 (0.53)
	.018 (0.46)
20	.031 (0.79)
	.029 (0.74)
16	.042 (1.07)
	.038 (0.97)
12	.096 (2.44)
	.092 (2.34)

Table III: Dimensions						
Shell Size	A +.000 (.00) -.010 (.25)	B ±.016 (.40)	Ø C ±.016 (.40)	D +.011 (.28) -.010 (.25)	E Thread UNEF-2A	F Thread UNEF-2A
9	.655 (16.6)	1.062 (27.0)	1.188 (30.2)	.109 (2.8)	.6875-24	.5625-24
11	.755 (19.2)	1.250 (31.8)	1.375 (34.9)	.109 (2.8)	.8125-20	.6875-24
13	.942 (23.9)	1.375 (34.9)	1.500 (38.1)	.109 (2.8)	1.0000-20	.8125-20
15	1.066 (27.1)	1.500 (38.1)	1.625 (41.3)	.109 (2.8)	1.1250-18	.9375-20
17	1.191 (30.3)	1.625 (41.3)	1.750 (44.5)	.109 (2.8)	1.2500-18	1.0625-18
19	1.316 (33.4)	1.812 (46.0)	1.938 (49.2)	.140 (3.6)	1.3750-18	1.0625-18
21	1.441 (36.6)	1.938 (49.2)	2.062 (52.4)	.140 (3.6)	1.5000-18	1.1875-18
23	1.566 (39.8)	2.062 (52.4)	2.188 (55.6)	.140 (3.6)	1.6250-18	1.3125-18
25	1.691 (43.0)	2.188 (55.6)	2.312 (58.7)	.140 (3.6)	1.7500-18	1.4375-18

Dimensions in inches (millimeters) and are subject to change without notice.



240-381S
MIL-DTL-38999 Series I Type Filter Connector
Jam Nut Receptacle with Crimp Removable Contacts

B

D38999 SERIES I TYPE JAM NUT RECEPTACLE WITH CRIMP REMOVABLE CONTACTS

How To Order										
Sample Part Number	240-381	S	ME	15-35	P	C	P	A	N	N
Filter Connector	MIL-DTL-38999 Series I Type									
Shell Style	S = Jam Nut Receptacle with Crimp Contacts									
Connector Class	See Table I									
Insert Arrangement	IAW MIL-STD-1560. (See pages B-4 – B-5)									
Contact Gender	P = Pin S = Socket									
Termination	C = Crimp									
Filter Type	P = Pi Circuit C = C Circuit (See Note 3)									
Capacitance	See Table II									
Flange Mounting Style	N = Not Applicable									
Alternate Key Position	A, B, C, D, N = Normal (See page B-5)									

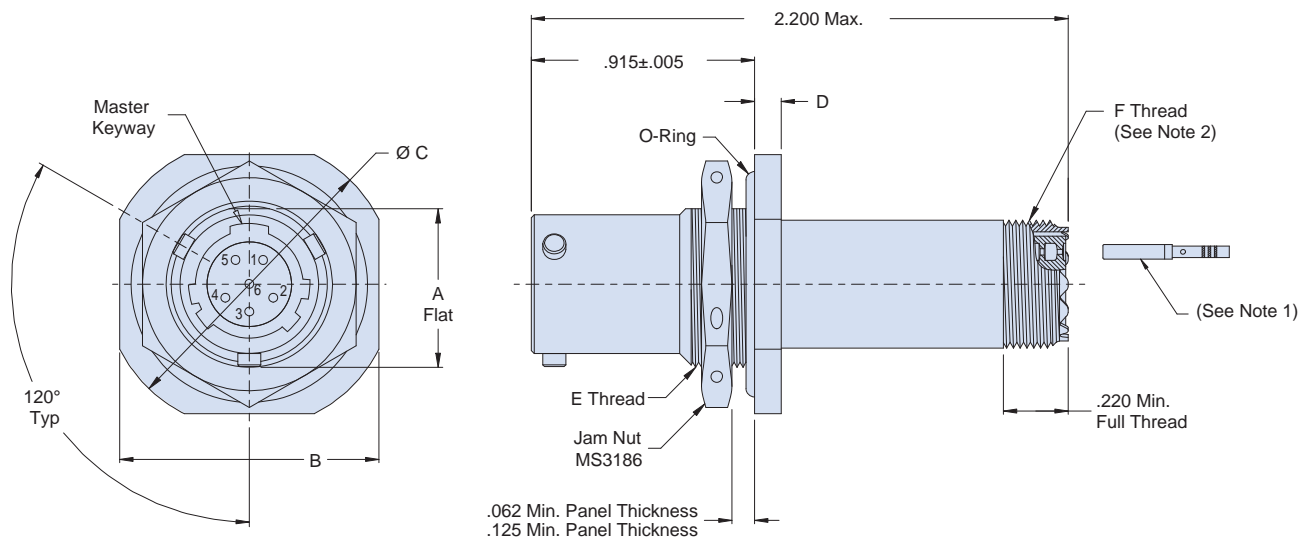

Notes

1. Crimp removable contacts to conform to MIL-C-39029/57-358, Size 16, MIL-C-39029/57-357 Size 20, and MIL-C-39029/57-354 Size 22D (Supplied loose).
2. "E" accessory threads for shell size 9 thru 17 are one size larger than MIL-DTL-38999 Series I to accommodate filters
3. Other filter styles (C-L, L-C, Unbalanced Pi, Multi-Stage, Multi-Value) are available, please consult the factory.

Dimensions in inches (millimeters) and are subject to change without notice.

240-381S
MIL-DTL-38999 Series I Type Filter Connector
Jam Nut Receptacle with Crimp Removable Contacts



MIL-DTL-38999
Type

B

Sym	Class	Material	Finish Description
ME	Environmental	Aluminum	Electroless Nickel
MT	Environmental	Aluminum	Ni-PTFE 1000 Hour Grey™ Nickel Fluorocarbon Polymer
NF	Environmental	Aluminum	Cadmium O.D. Over Electroless Nickel
ZL	Environmental	Stainless Steel	Electro-Deposited Nickel
ZN	Environmental	Aluminum	Zinc-Nickel, Olive Drab
ZR	Environmental	Aluminum	Zinc Nickel, Black - RoHS
H2*	Hermetic	Stainless Steel	Electro-Deposited Nickel

*Some dimensions do not apply. See drawing 240-381SH2

Class	Pi - Circuit (pF)	C - Circuit (pF)
X*	160,000 - 240,000	80,000 - 120,000
Y*	80,000 - 120,000	40,000 - 60,000
Z*	60,000 - 90,000	30,000 - 45,000
A	38,000 - 56,000	19,000 - 28,000
B	32,000 - 45,000	16,000 - 22,500
C	18,000 - 33,000	9,000 - 16,500
D	8,000 - 12,000	4,000 - 6,000
E	3,300 - 5,000	1,650 - 2,500
F	800 - 1,300	400 - 650
G	400 - 600	200 - 300
J	70-120	35-60

* Filter Classes X, Y and Z are 250 VDC.
All others are 500 VDC

Shell Size	A +.000 (.00) -.010 (.25)	B ±.016 (.40)	Ø C ±.016 (.40)	D +.011 (.28) -.010 (.25)	E Thread UNEF-2A	F Thread UNEF-2A
9	.655 (16.6)	1.062 (27.0)	1.188 (30.2)	.109 (2.8)	.6875-24	.5625-24
11	.755 (19.2)	1.250 (31.8)	1.375 (34.9)	.109 (2.8)	.8125-20	.6875-24
13	.942 (23.9)	1.375 (34.9)	1.500 (38.1)	.109 (2.8)	1.0000-20	.8125-20
15	1.066 (27.1)	1.500 (38.1)	1.625 (41.3)	.109 (2.8)	1.1250-18	.9375-20
17	1.191 (30.3)	1.625 (41.3)	1.750 (44.5)	.109 (2.8)	1.2500-18	1.0625-18
19	1.316 (33.4)	1.812 (46.0)	1.938 (49.2)	.140 (3.6)	1.3750-18	1.0625-18
21	1.441 (36.6)	1.938 (49.2)	2.062 (52.4)	.140 (3.6)	1.5000-18	1.1875-18
23	1.566 (39.8)	2.062 (52.4)	2.188 (55.6)	.140 (3.6)	1.6250-18	1.3125-18
25	1.691 (43.0)	2.188 (55.6)	2.312 (58.7)	.140 (3.6)	1.7500-18	1.4375-18

Dimensions in inches (millimeters) and are subject to change without notice.

D38999 SERIES I TYPE CONNECTOR ADAPTER

How To Order									
Sample Part Number	240-381	A	ME	15-35	PS	P	A	N	U
Filter Connector	MIL-DTL-38999 Series I Type								
Shell Style	A = Connector Adapter								
Connector Class	See Table I								
Insert Arrangement	IAW MIL-STD-1560. (See pages B-4 – B-5)								
Contact Gender	PS = Pins, Plug Side SP = Sockets, Plug Side (See Note 2)								
Filter Type	P = Pi Circuit C = C Circuit (See Note 1)								
Capacitance	See Table II								
Flange Mounting Style	N = Not Applicable								
Alternate Key Position	A, B, C, D, N = Normal, U = Universal (See page B-5) (See Note 3)								

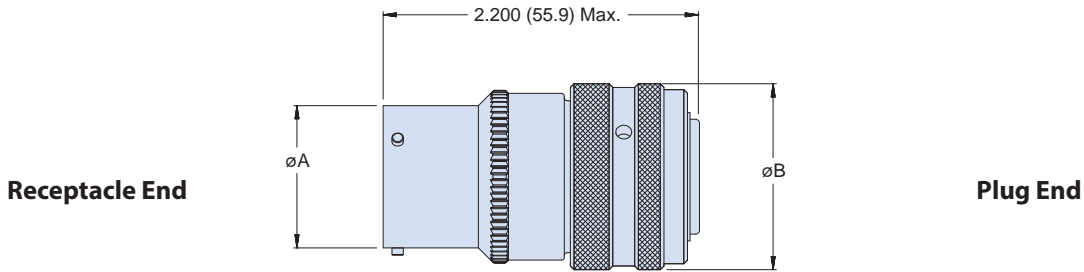

* Please consult the factory for Pin/Pin and/or Socket/Socket contact arrangements.

Notes

1. Other filter styles (C-L, L-C, Unbalanced Pi, Multi-Stage, Multi-Value) are available, please consult the factory.
2. Please consult the factory for Pin/Pin and/or Socket/Socket contact arrangements.
3. Do not mate Universal key position with another Universal.

Dimensions in inches (millimeters) and are subject to change without notice.

240-381A
MIL-DTL-38999 Series I Type Filter Connector
Connector Adapter



MIL-DTL-38999
Type

B

Table I: Connector Class			
Sym	Class	Material	Finish Description
ME	Environmental	Aluminum	Electroless Nickel
MT	Environmental	Aluminum	Ni-PTFE 1000 Hour Grey™ Nickel Fluorocarbon Polymer
NF	Environmental	Aluminum	Cadmium O.D. Over Electroless Nickel
ZL	Environmental	Stainless Steel	Electro-Deposited Nickel
ZN	Environmental	Aluminum	Zinc-Nickel, Olive Drab
ZR	Environmental	Aluminum	Zinc Nickel, Black - RoHS

Table II: Capacitor Array Code Capacitance Range		
Class	Pi - Circuit (pF)	C - Circuit (pF)
X*	160,000 - 240,000	80,000 - 120,000
Y*	80,000 - 120,000	40,000 - 60,000
Z*	60,000 - 90,000	30,000 - 45,000
A	38,000 - 56,000	19,000 - 28,000
B	32,000 - 45,000	16,000 - 22,500
C	18,000 - 33,000	9,000 - 16,500
D	8,000 - 12,000	4,000 - 6,000
E	3,300 - 5,000	1,650 - 2,500
F	800 - 1,300	400 - 650
G	400 - 600	200 - 300
J	70-120	35-60

* Filter Classes X, Y and Z are 250 VDC.
All others are 500 VDC

Table III: Dimensions		
Shell Size	Ø A Max	Ø B Max
9	.573 (14.6)	.910 (23.1)
11	.701 (17.8)	1.035 (26.3)
13	.851 (21.6)	1.210 (30.7)
15	.976 (24.8)	1.330 (33.8)
17	1.101 (28.0)	1.455 (37.0)
19	1.208 (30.7)	1.570 (39.9)
21	1.333 (33.9)	1.695 (43.1)
23	1.458 (37.0)	1.800 (45.7)
25	1.583 (40.2)	1.925 (48.9)

Dimensions in inches (millimeters) and are subject to change without notice.

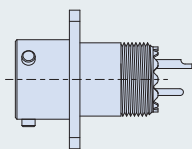
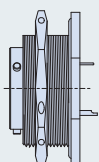
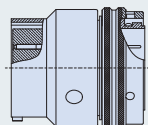
**240-382W****Wall Mount Receptacles****Page
B-20****240-382J****Jam Nut Receptacles****Page
B-22****240-382A****Connector Adapters****Page
B-24**

Notes

1. Materials/Finishes: Shells, Barrel, Coupling Nut, Jam Nut - See Table I
Insulators - High grade rigid dielectric/N.A.
Seals - Fluorosilicone
Contacts: Copper alloy 50 μ " Gold over 50 μ " Nickel
2. Assembly to be identified with Glenair's name, part number, and date code - space permitting.
3. Insert Arrangement in accordance with MIL-STD-1560. (Arrangement shown for reference only)
4. EMI Circular Filter Receptacle connectors designed to meet requirements of MIL-STD-2120 and MIL-DTL-38999, Series II.
5. All contacts to have identical filter value. Other filter arrangements available, contact factory.
6. Electrical Ratings: DWV- 500 VDC; Standard Operating Voltage 200 VDC (Filter class X, Y and Z are 250 VDC)
7. Insulation Resistance: 5000 MegOhms at 200 VDC for classes A, B, C, D, E, F, G, J. 1000 MegOhms at 83 VDC for classes X, Y, Z
8. Operating Temperature: -55°C to +125°C (Env Class Connectors)
9. Other filter styles (C-L, L-C, Unbalanced Pi, Multi-Stage, Multi-Value) are available, please consult the factory.

Dimensions in inches (millimeters) and are subject to change without notice.

MIL-DTL-38999 Series II Type Filter Connectors Panel Cut-Outs



MIL-DTL-38999
Type

B

Back Panel Mounting

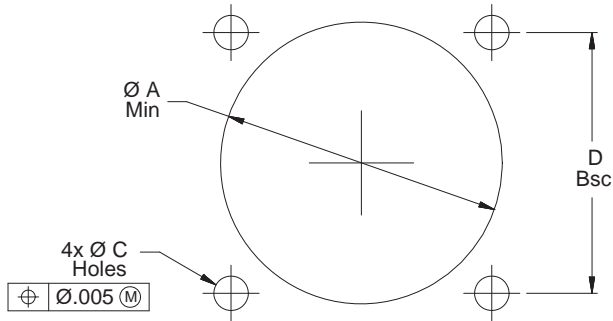

Front Panel Mounting

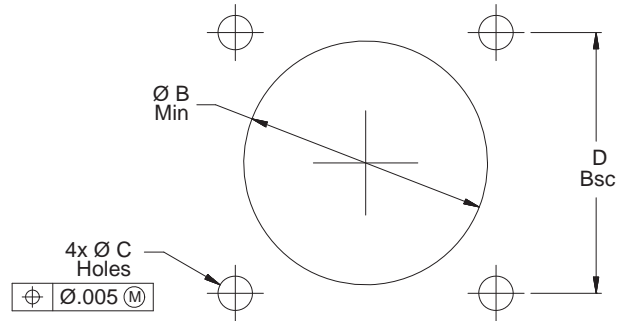

MIL-DTL-38999 Series II Square Flange Panel Cut-Outs				
Shell Size	Ø A Min Back Panel	Ø B Min * Front Panel	Ø C Holes	D Bsc
8	.557 (14.2)	.625 (15.9)	.123 (3.1) .133 (3.4)	.594 (15.1)
10	.682 (17.3)	.750 (19.1)		.719 (18.3)
12	.854 (21.7)	.906 (23.0)		.812 (20.6)
14	.979 (24.9)	1.016 (25.8)		.906 (23.0)
16	1.104 (28.0)	1.141 (29.0)		.969 (24.6)
18	1.229 (31.2)	1.141 (29.0)		1.062 (27.0)
20	1.354 (34.4)	1.266 (32.2)		1.156 (29.4)
22	1.479 (37.6)	1.375 (34.9)		1.250 (31.8)
24	1.604 (40.7)	1.484 (37.7)	.149 (3.8) .159 (4.0)	1.375 (34.9)

*Note: Accessory threads for shell size 8 thru 16 are one size larger than MIL-DTL-38999 Series II to accommodate filters. Recommended front panel cut-outs (Ø B) modified accordingly.

MIL-DTL-38999 Series II Jam Nut Panel Cut-Out		
Shell Size	Ø E	F Flat
8	.895 (22.7)	.830 (21.1)
	.885 (22.5)	.820 (20.8)
10	1.020 (25.9)	.955 (24.3)
	1.010 (25.7)	.945 (24.0)
12	1.145 (29.1)	1.085 (27.6)
	1.135 (28.8)	1.075 (27.3)
14	1.270 (32.3)	1.210 (30.7)
	1.260 (32.0)	1.200 (30.5)
16	1.395 (35.4)	1.335 (33.9)
	1.385 (35.2)	1.325 (33.7)
18	1.520 (38.6)	1.460 (37.1)
	1.510 (38.4)	1.450 (36.8)
20	1.645 (41.8)	1.585 (40.3)
	1.635 (41.5)	1.575 (40.0)
22	1.770 (45.0)	1.709 (43.4)
	1.760 (44.7)	1.699 (43.2)
24	1.895 (48.1)	1.835 (46.6)
	1.885 (47.9)	1.825 (46.4)

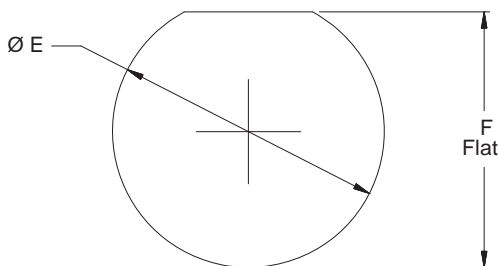

Dimensions in inches (millimeters) and are subject to change without notice.



MIL-STD-1560 Insert Arrangements (Pin Front View) and Shell Polarization for MIL-DTL-38999 Series II Type Filter Connectors

B

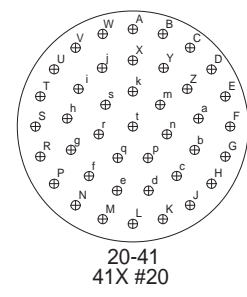
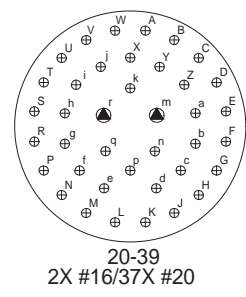
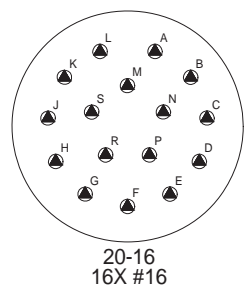
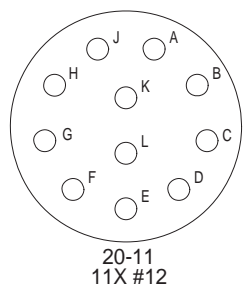
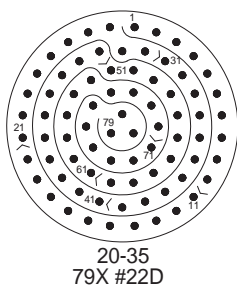
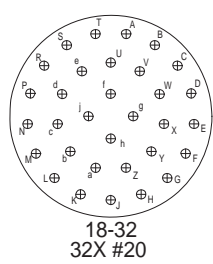
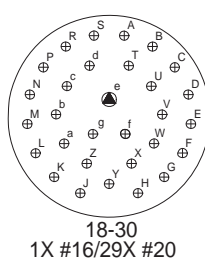
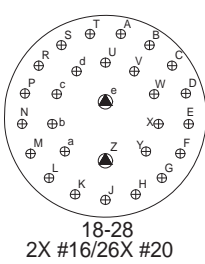
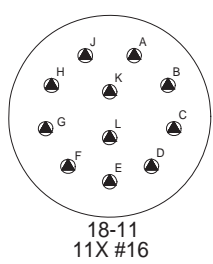
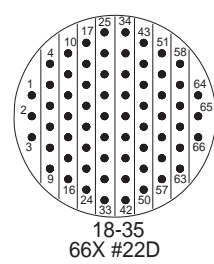
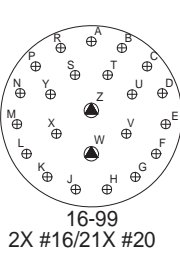
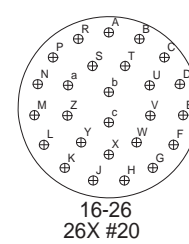
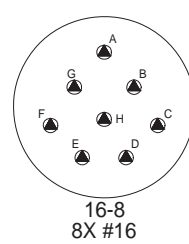
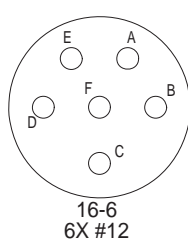
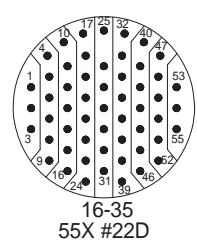
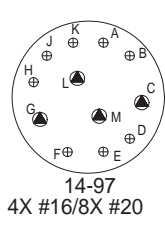
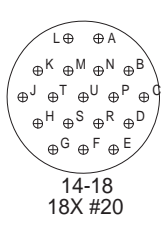
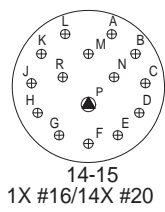
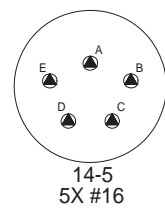
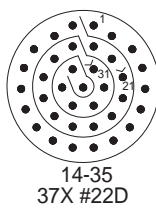
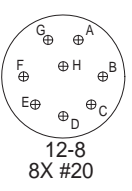
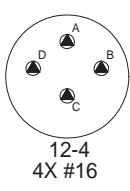
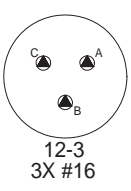
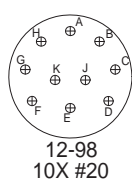
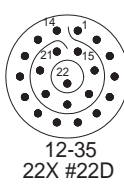
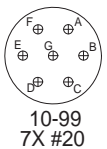
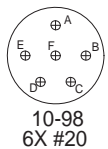
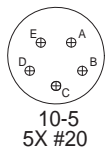
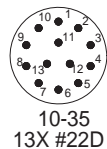
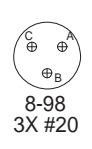

SYM	SIZE
●	#22D
⊕	#20
⊙	#16
○	#12

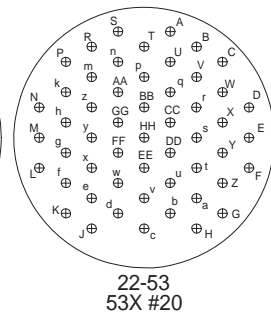
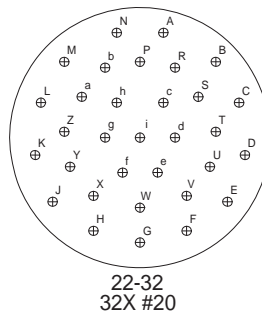
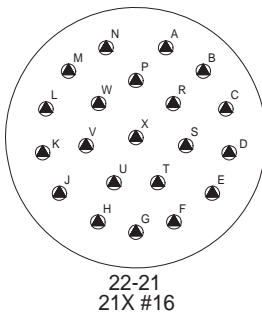
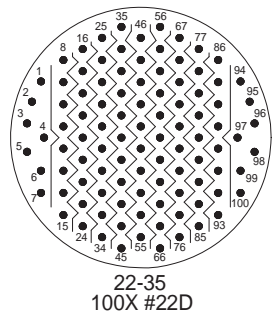

Dimensions in inches (millimeters) and are subject to change without notice.

MIL-STD-1560 Insert Arrangements (Pin Front View) and Shell Polarization for MIL-DTL-38999 Series II Type Filter Connectors



MIL-DTL-38999
Type

B

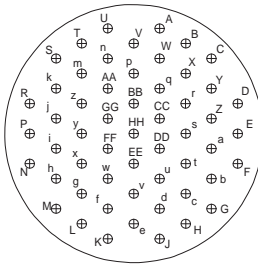

22-55
55X #20

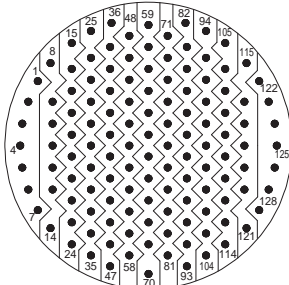

24-35
128X #22D

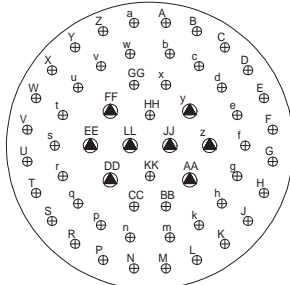

24-4
8X #16/48X #20

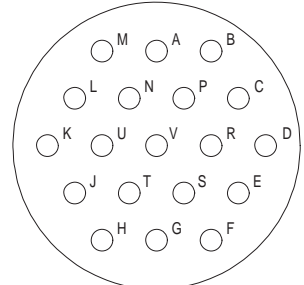

24-19
19X #12

SYM	SIZE
●	#22D
⊕	#20
▲	#16
○	#12

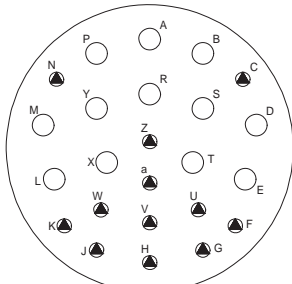

24-24
12X #12/12X #16

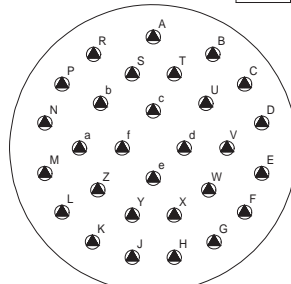

24-29
29X #16

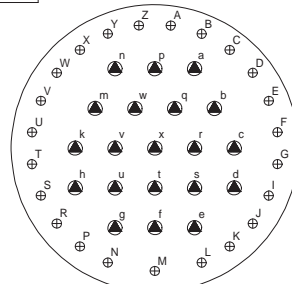

24-43
20X #16/23X #20

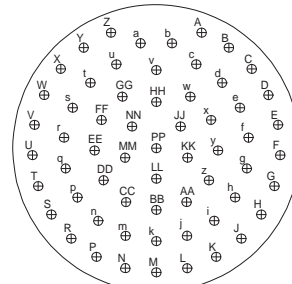

24-61
61X #20

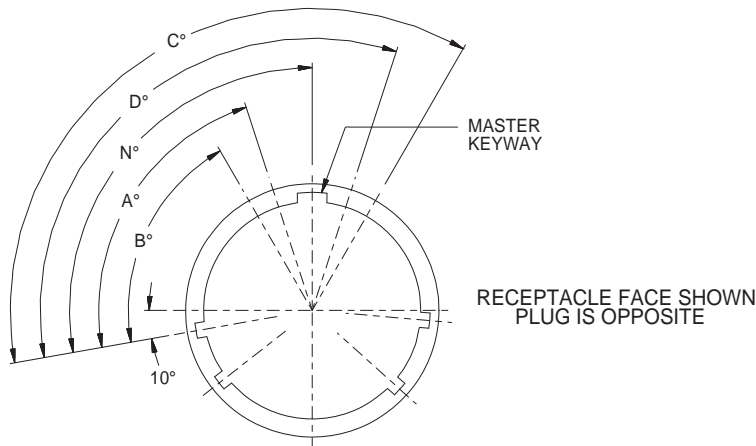

NOTE: MASTER KEY & KEYWAY HAS VARIOUS POSITIONS WHILE MINOR KEYS AND KEYWAYS REMAIN FIXED.

MIL-DTL-38999 Series II Keying Positions					
Shell Size	N° Bsc	A° Bsc	B° Bsc	C° Bsc	D° Bsc
8	100°	82°	-	-	118°
10	100°	86°	72°	128°	114°
12	100°	80°	68°	132°	120°
14	100°	79°	66°	134°	121°
16	100°	82°	70°	130°	118°
18	100°	82°	70°	130°	118°
20	100°	82°	70°	130°	118°
22	100°	85°	74°	126°	115°
24	100°	85°	74°	126°	115°

Dimensions in inches (millimeters) and are subject to change without notice.

© 2013 Glenair, Inc.

U.S. CAGE Code 06324

Printed in U.S.A.

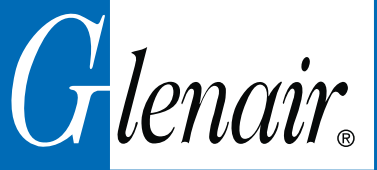

240-382W
MIL-DTL-38999 Series II Type Filter Connector
Wall Mount Receptacle

B

D38999 SERIES II TYPE WALL MOUNT RECEPTACLE

How To Order										
Sample Part Number	240-382	W	ME	14-35	P	S	P	A	C	N
Filter Connector	MIL-DTL-38999 Series II Type									
Shell Style	W = Wall Mount									
Connector Class	See Table I									
Insert Arrangement	IAW MIL-STD-1560. (See pages B-18 - B-19)									
Contact Gender	P = Pin S = Socket									
Termination	S = Solder Cup P = PC Tail									
Filter Type	P = Pi Circuit C = C Circuit (See Note 2)									
Capacitance	See Table II									
Flange Mounting Style	H = Round Holes C = Clinch Nuts (4-40 UNC) M = Metric Clinch Nuts (M3)									
Alternate Key Position	A, B, C, D, N = Normal (See page B-19)									

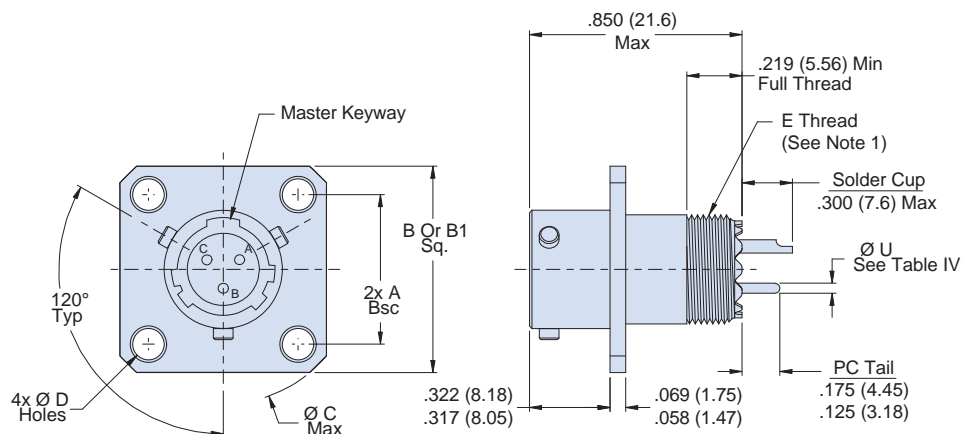

Notes

1. "E" accessory threads for shell size 8 thru 16 are one size larger than MIL-DTL-38999 Series II to accommodate filters
2. Other filter styles (C-L, L-C, Unbalanced Pi, Multi-Stage, Multi-Value) are available, please consult the factory.

Dimensions in inches (millimeters) and are subject to change without notice.

240-382W
MIL-DTL-38999 Series II Type Filter Connector
Wall Mount Receptacle



MIL-DTL-38999
Type

B

Table I: Connector Class			
Sym	Class	Material	Finish Description
ME	Environmental	Aluminum	Electroless Nickel
MT	Environmental	Aluminum	Ni-PTFE 1000 Hour Grey™ Nickel Fluorocarbon Polymer
NF	Environmental	Aluminum	Cadmium O.D. Over Electroless Nickel
ZL	Environmental	Stainless Steel	Electro-Deposited Nickel
ZN	Environmental	Aluminum	Zinc-Nickel, Olive Drab
ZR	Environmental	Aluminum	Zinc Nickel, Black - RoHS
H2*	Hermetic	Stainless Steel	Electro-Deposited Nickel

*Some dimensions do not apply. See drawing 240-382WH2

Table II: Capacitor Array Code Capacitance Range		
Class	Pi - Circuit (pF)	C - Circuit (pF)
X*	160,000 - 240,000	80,000 - 120,000
Y*	80,000 - 120,000	40,000 - 60,000
Z*	60,000 - 90,000	30,000 - 45,000
A	38,000 - 56,000	19,000 - 28,000
B	32,000 - 45,000	16,000 - 22,500
C	18,000 - 33,000	9,000 - 16,500
D	8,000 - 12,000	4,000 - 6,000
E	3,300 - 5,000	1,650 - 2,500
F	800 - 1,300	400 - 650
G	400 - 600	200 - 300
J	70-120	35-60

* Filter Classes X, Y and Z are 250 VDC.
All others are 500 VDC

Table IV: PC Tail Dia	
Contact Size	Ø U
22D	.021 (0.53)
	.018 (0.46)
20	.031 (0.79)
	.029 (0.74)
16	.042 (1.07)
	.038 (0.97)
12	.096 (2.44)
	.092 (2.34)

Table III: Dimensions						
Shell Size	A Bsc	Thru Hole Flange		Clinch Nut Flange	Ø C Max	E Thread UNEF-2A
		B Sq. Max	Ø D +.010 (.25) -.005 (.13)	B1 Sq. ±.020 (.51)		
8	.594 (15.1)	.828 (21.0)	.120 (3.0)	.895 (22.7)	1.250 (31.8)	.5625-24
10	.719 (18.3)	.954 (24.2)	.120 (3.0)	1.019 (25.9)	1.400 (35.6)	.6875-24
12	.812 (20.6)	1.047 (26.6)	.120 (3.0)	1.112 (28.2)	1.500 (38.1)	.8125-20
14	.906 (23.0)	1.141 (29.0)	.120 (3.0)	1.206 (30.6)	1.650 (41.9)	.9375-20
16	.969 (24.6)	1.234 (31.3)	.120 (3.0)	1.269 (32.2)	1.700 (43.2)	1.0625-18
18	1.062 (27.0)	1.328 (33.7)	.120 (3.0)	1.362 (34.6)	1.800 (45.7)	1.0625-18
20	1.156 (29.4)	1.453 (39.9)	.120 (3.0)	1.456 (37.0)	2.000 (50.8)	1.1875-18
22	1.250 (31.8)	1.578 (40.1)	.120 (3.0)	1.562 (39.7)	2.150 (54.6)	1.3125-18
24	1.375 (34.9)	1.703 (43.3)	.147 (3.7)	1.719 (43.7)	2.280 (57.9)	1.4375-18

Dimensions in inches (millimeters) and are subject to change without notice.

D38999 SERIES II TYPE JAM NUT RECEPTACLE

How To Order										
Sample Part Number	240-382	J	MT	14-35	P	S	P	A	N	N
Filter Connector	MIL-DTL-38999 Series II Type									
Shell Style	J = Jam Nut									
Connector Class	See Table I									
Insert Arrangement	IAW MIL-STD-1560. (See pages B-18 – B-19)									
Contact Gender	P = Pin S = Socket									
Termination	S = Solder Cup P = PC Tail									
Filter Type	P = Pi Circuit C = C Circuit (See Note 1)									
Capacitance	See Table II									
Flange Mounting Style	N = Not Applicable									
Alternate Key Position	A, B, C, D, N = Normal (See page B-19)									

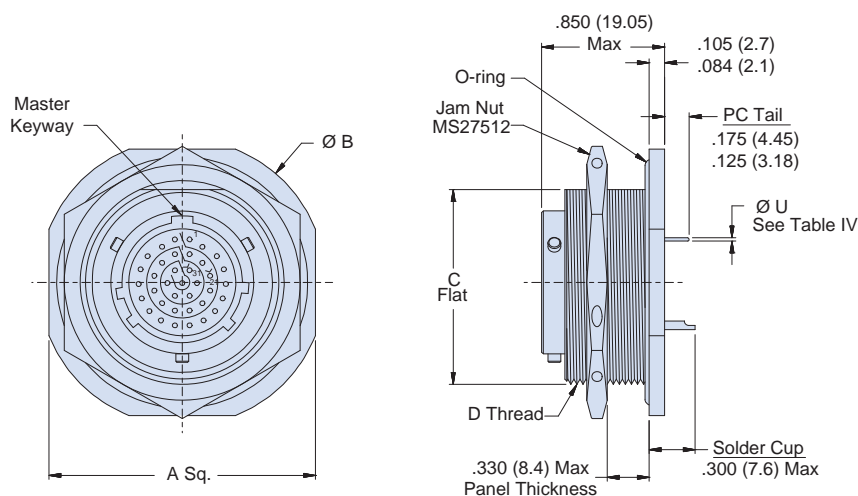

Notes

1. Other filter styles (C-L, L-C, Unbalanced Pi, Multi-Stage, Multi-Value) are available, please consult the factory.

Dimensions in inches (millimeters) and are subject to change without notice.

240-382J
MIL-DTL-38999 Series II Type Filter Connector
Jam Nut Receptacle



MIL-DTL-38999
Type

B

Table I: Connector Class			
Sym	Class	Material	Finish Description
ME	Environmental	Aluminum	Electroless Nickel
MT	Environmental	Aluminum	Ni-PTFE 1000 Hour Grey™ Nickel Fluorocarbon Polymer
NF	Environmental	Aluminum	Cadmium O.D. Over Electroless Nickel
ZL	Environmental	Stainless Steel	Electro-Deposited Nickel
ZN	Environmental	Aluminum	Zinc-Nickel, Olive Drab
ZR	Environmental	Aluminum	Zinc Nickel, Black - RoHS
H2*	Hermetic	Stainless Steel	Electro-Deposited Nickel

*Some dimensions do not apply. See drawing 240-382JH2

Table II: Capacitor Array Code Capacitance Range		
Class	Pi - Circuit (pF)	C - Circuit (pF)
X*	160,000 - 240,000	80,000 - 120,000
Y*	80,000 - 120,000	40,000 - 60,000
Z*	60,000 - 90,000	30,000 - 45,000
A	38,000 - 56,000	19,000 - 28,000
B	32,000 - 45,000	16,000 - 22,500
C	18,000 - 33,000	9,000 - 16,500
D	8,000 - 12,000	4,000 - 6,000
E	3,300 - 5,000	1,650 - 2,500
F	800 - 1,300	400 - 650
G	400 - 600	200 - 300
J	70-120	35-60

* Filter Classes X, Y and Z are 250 VDC.
 All others are 500 VDC

Table IV: PC Tail Dia	
Contact Size	Ø U
22D	.021 (0.53) .018 (0.46)
20	.031 (0.79) .029 (0.74)
16	.042 (1.07) .038 (0.97)
12	.096 (2.44) .092 (2.34)

Table III: Dimensions				
Shell Size	A Sq. ±.016 (.40)	Ø B ±.016 (.40)	C Flat +.001 (.03) -.006 (.15)	D Thread Class 2A
8	1.250 (31.8)	1.375 (34.9)	.817 (20.8)	.875-20 UNEF
10	1.375 (34.9)	1.500 (38.1)	.941 (23.9)	1.000-20 UNEF
12	1.500 (38.1)	1.625 (41.3)	1.065 (27.1)	1.125-18 UNEF
14	1.625 (41.3)	1.750 (44.5)	1.190 (30.2)	1.250-18 UNEF
16	1.781 (45.2)	1.938 (49.2)	1.320 (33.5)	1.375-18 UNEF
18	1.890 (48.0)	2.016 (51.2)	1.440 (36.6)	1.500-18 UNEF
20	2.016 (51.2)	2.141 (54.4)	1.565 (39.8)	1.625-18 UNEF
22	2.140 (54.4)	2.265 (57.5)	1.690 (42.9)	1.750-18 UNS
24	2.265 (57.5)	2.390 (60.7)	1.815 (46.1)	1.875-16 UN

Dimensions in inches (millimeters) and are subject to change without notice.

240-382A
MIL-DTL-38999 Series II Type Filter Connector
Connector Adapter



MIL-DTL-38999
Type

B

Sym	Class	Material	Finish Description
ME	Environmental	Aluminum	Electroless Nickel
MT	Environmental	Aluminum	Ni-PTFE 1000 Hour Grey™ Nickel Fluorocarbon Polymer
NF	Environmental	Aluminum	Cadmium O.D. Over Electroless Nickel
ZL	Environmental	Stainless Steel	Electro-Deposited Nickel
ZN	Environmental	Aluminum	Zinc-Nickel, Olive Drab
ZR	Environmental	Aluminum	Zinc Nickel, Black - RoHS

Class	Pi - Circuit (pF)	C - Circuit (pF)
X*	160,000 - 240,000	80,000 - 120,000
Y*	80,000 - 120,000	40,000 - 60,000
Z*	60,000 - 90,000	30,000 - 45,000
A	38,000 - 56,000	19,000 - 28,000
B	32,000 - 45,000	16,000 - 22,500
C	18,000 - 33,000	9,000 - 16,500
D	8,000 - 12,000	4,000 - 6,000
E	3,300 - 5,000	1,650 - 2,500
F	800 - 1,300	400 - 650
G	400 - 600	200 - 300
J	70-120	35-60

* Filter Classes X, Y and Z are 250 VDC.
All others are 500 VDC

Shell Size	Ø A Max	Ø B Max
8	.474 (12.0)	.784 (19.9)
10	.591 (15.0)	.894 (22.7)
12	.751 (19.1)	1.031 (26.2)
14	.876 (22.3)	1.156 (29.4)
16	1.001 (25.4)	1.281 (32.5)
18	1.126 (28.6)	1.406 (35.7)
20	1.251 (31.8)	1.531 (38.9)
22	1.376 (35.0)	1.641 (41.7)
24	1.501 (38.1)	1.766 (44.8)

Dimensions in inches (millimeters) and are subject to change without notice.

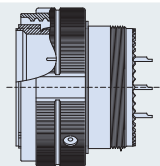
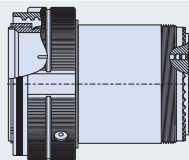
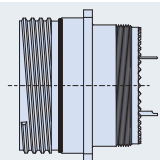
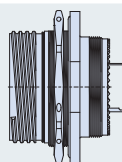
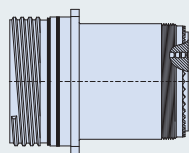
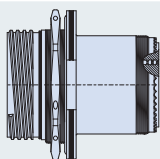
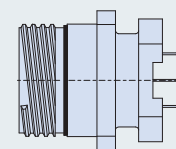
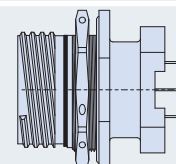
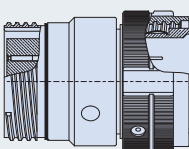
**240-383P****Plugs****Page
B-30****240-383Q*****New!* Plugs with Crimp
Removable Contacts****Page
B-32****240-383W****Wall Mount Receptacles****Page
B-34****240-383J****Jam Nut Receptacles****Page
B-36****240-383R****Wall Mount Receptacles
with Crimp Removable Contacts****Page
B-38****240-383S****Jam Nut Receptacles
with Crimp Removable Contacts****Page
B-40****240-383D****Dual Flange Wall Mount Receptacles
with PC Tails****Page
B-42****240-383E****Dual Flange Jam Nut Receptacles
with PC Tails****Page
B-44****240-383B****Connector Adapters****Page
B-46**

Dimensions in inches (millimeters) and are subject to change without notice.

MIL-DTL-38999 Series III Type Filter Connector with Threaded Coupling



MIL-DTL-38999
Type

B

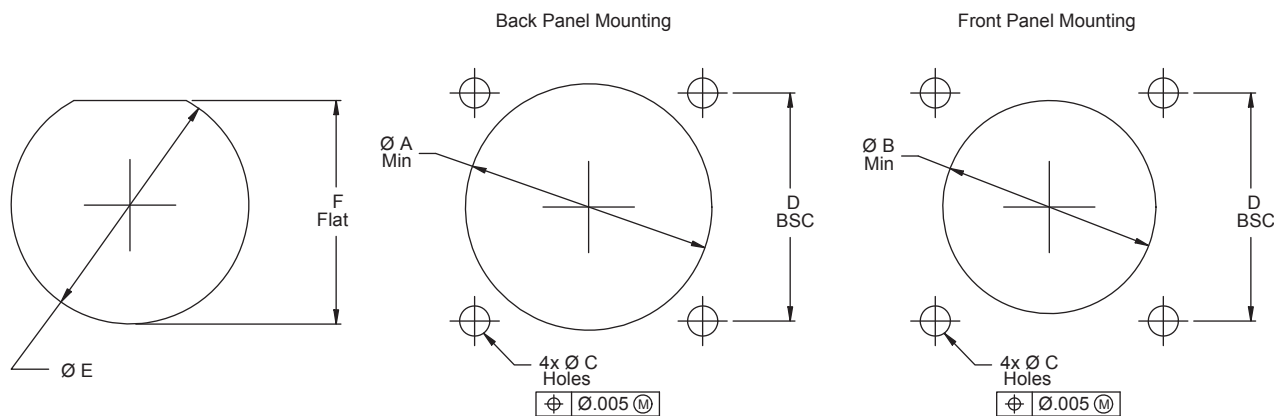

Square Flange Panel Cut-Outs MIL-DTL-38999 Series III				
Shell Size	Ø A Min Back Panel	Ø B Min Front Panel	Ø C Holes	D Bsc
9	.656 (16.7)	.516 (13.1)	.133 (3.4) .123 (3.1)	.719 (18.3)
11	.796 (20.2)	.625 (15.9)		.812 (20.6)
13	.922 (23.4)	.750 (19.1)		.906 (23.0)
15	1.047 (26.6)	.906 (23.0)		.969 (24.6)
17	1.219 (31.0)	1.016 (25.8)		1.062 (27.0)
19	1.297 (32.9)	1.141 (29.0)		1.156 (29.4)
21	1.422 (36.1)	1.266 (32.2)		1.250 (31.8)
23	1.547 (39.3)	1.375 (34.9)	.159 (4.0) .149 (3.8)	1.375 (34.9)
25	1.672 (42.5)	1.484 (37.7)	.155 (3.9) .145 (3.7)	1.500 (38.1)

Jam Nut Panel Cut-Out MIL-DTL-38999 Series III		
Shell Size	Ø E	F Flat
9	.710 (18.0)	.670 (17.0)
	.700 (17.8)	.660 (16.8)
11	.835 (21.2)	.771 (19.6)
	.825 (21.0)	.761 (19.3)
13	1.020 (25.9)	.955 (24.3)
	1.010 (25.7)	.945 (24.0)
15	1.145 (29.1)	1.085 (27.6)
	1.135 (28.8)	1.075 (27.3)
17	1.270 (32.3)	1.210 (30.7)
	1.260 (32.0)	1.200 (30.5)
19	1.395 (35.4)	1.335 (33.9)
	1.385 (35.2)	1.325 (33.7)
21	1.520 (38.6)	1.460 (37.1)
	1.510 (38.4)	1.450 (36.8)
23	1.645 (41.8)	1.585 (40.3)
	1.635 (41.5)	1.575 (40.0)
25	1.770 (45.0)	1.710 (43.4)
	1.760 (44.7)	1.700 (43.2)

Notes

- Materials/Finishes: Shells, Barrel, Coupling Nut, Jam Nut - See Table I
Insulators - High grade rigid dielectric/N.A.
Seals - Fluorosilicone
Contacts: Copper alloy 50µ" Gold over 50µ" Nickel
- Assembly to be identified with Glenair's name, part number, and date code - space permitting.
- Insert Arrangement in accordance with MIL-STD-1560. (Arrangement shown for reference only)
- EMI Circular Filter Receptacle connectors designed to meet requirements of MIL-STD-2120 and MIL-DTL-38999, Series III.
- All contacts to have identical filter value. Other filter arrangements available, contact factory.
- Electrical Ratings: DWV- 500 VDC; Standard Operating Voltage 200 VDC (Filter class X, Y and Z are 250 VDC)
- Insulation Resistance: 5000 MegOhms at 200 VDC for classes A, B, C, D, E, F, G, J. 1000 MegOhms at 83 VDC for classes X, Y, Z
- Operating Temperature: -55°C to +125°C (Env Class Connectors)
- Other filter styles (C-L, L-C, Unbalanced Pi, Multi-Stage, Multi-Value) are available, please consult the factory.

Dimensions in inches (millimeters) and are subject to change without notice.

© 2013 Glenair, Inc.

U.S. CAGE Code 06324

Printed in U.S.A.

GLENAIR, INC. • 1211 AIR WAY • GLENDALE, CA 91201-2497 • 818-247-6000 • FAX 818-500-9912
www.glenair.com **B-27** E-Mail: sales@glenair.com

Rev. 10.22.21

MIL-STD-1560 Insert Arrangements (Pin Front View) and Shell Polarization for MIL-DTL-38999 Series III Type Filter Connectors

B

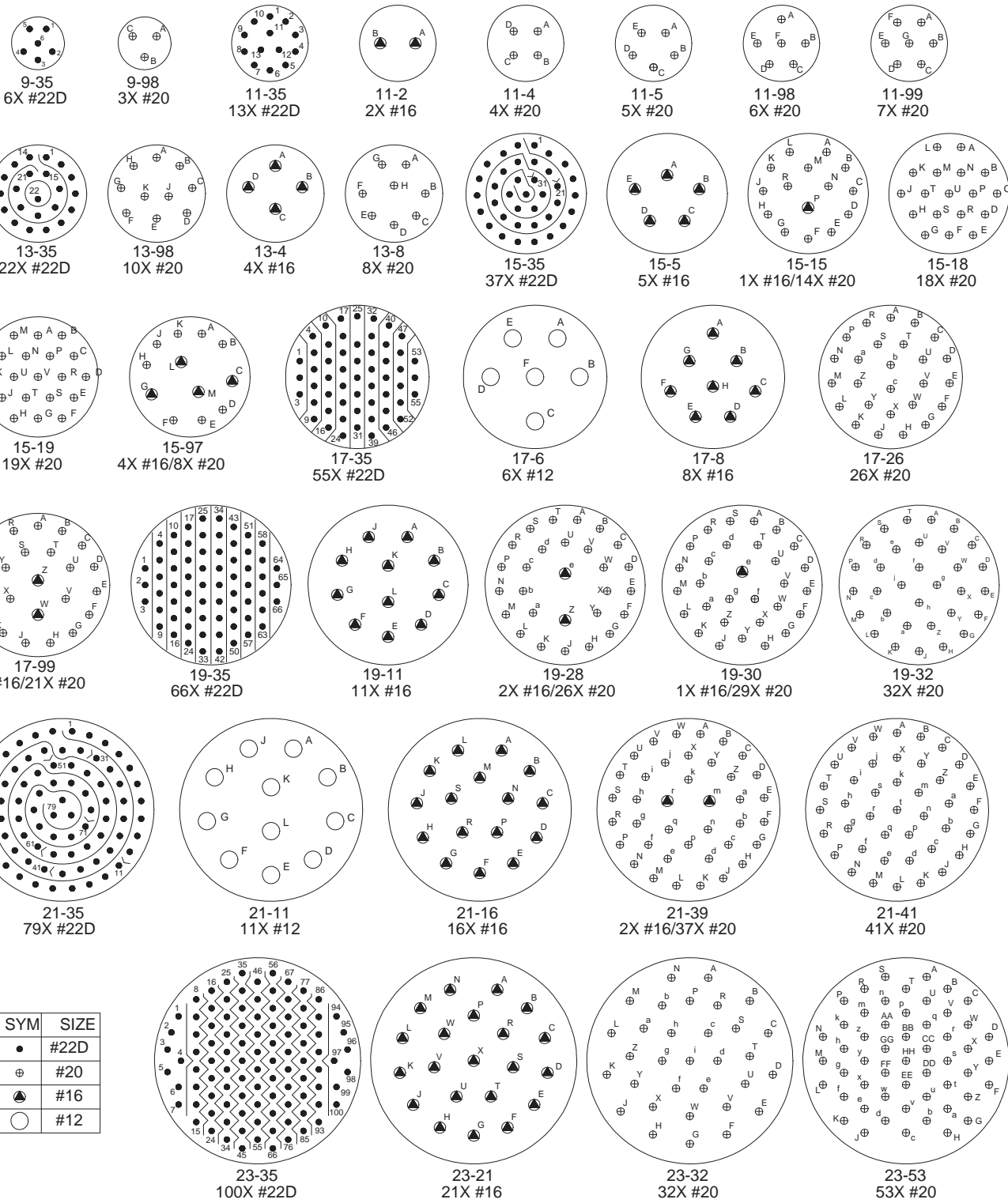

Dimensions in inches (millimeters) and are subject to change without notice.

MIL-STD-1560 Insert Arrangements (Pin Front View) and Shell Polarization for MIL-DTL-38999 Series III Type Filter Connectors



MIL-DTL-38999
Type

B

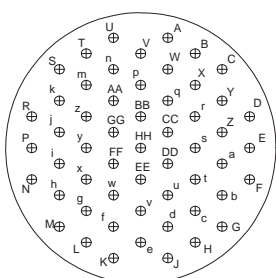

23-55
55X #20

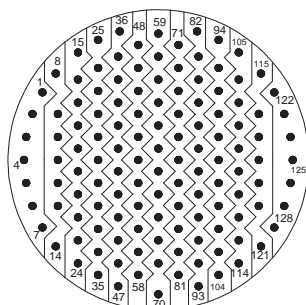

25-35
128X #22D

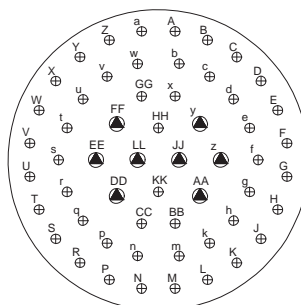

25-4
8X #16/48X #20

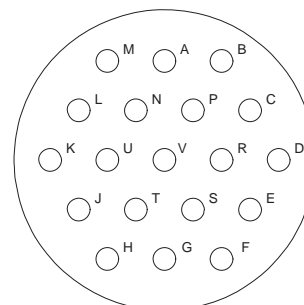

25-19
19X #12

SYM	SIZE
●	#22D
⊕	#20
▲	#16
○	#12

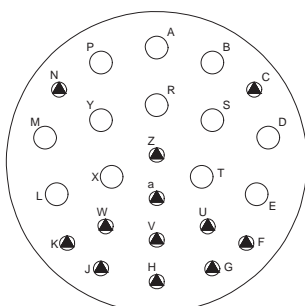

25-24
12X #12/12X #16

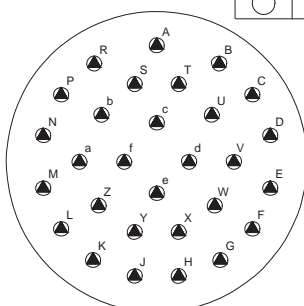

25-29
29X #16

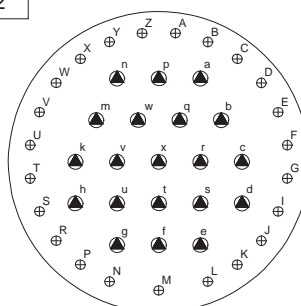

25-43
20X #16/23X #20

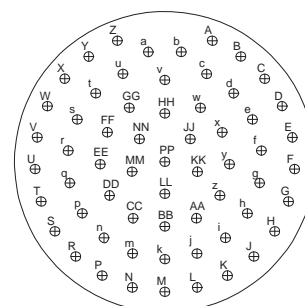

25-61
61X #20

RECEPTACLE

PLUG

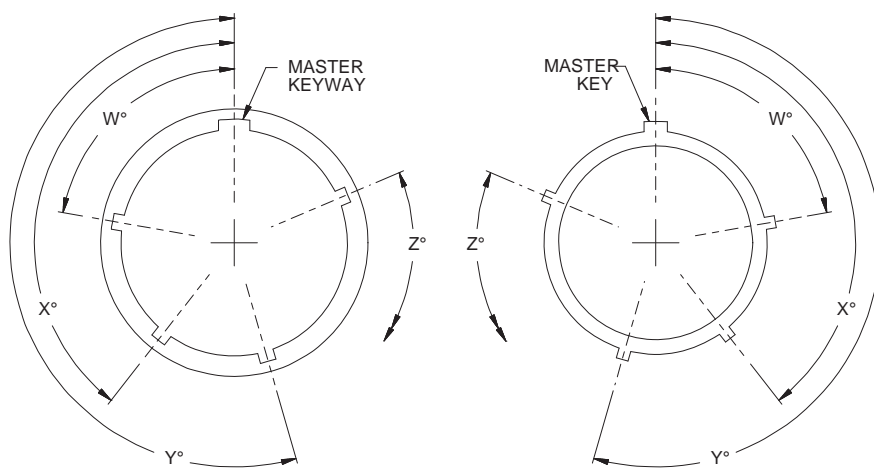

NOTE: ALL MINOR KEYS AND KEYWAYS ARE ROTATED TO PROVIDE POLARIZATION WHILE MASTER KEY AND KEYWAY REMAIN FIXED.

MIL-DTL-38999 Series III Keying Positions

Shell Size	Keying Position	W° Bsc	X° Bsc	Y° Bsc	Z° Bsc
9	N	105°	140°	215°	265°
	A	102°	132°	248°	320°
	B	80°	118°	230°	312°
	C	35°	140°	205°	275°
	D	64°	155°	234°	304°
11 13 15	E	91°	131°	197°	240°
	N	95°	141°	208°	236°
	A	113°	156°	182°	292°
	B	90°	145°	195°	252°
	C	53°	156°	220°	255°
17 19 21 23 25	D	119°	146°	176°	298°
	E	51°	141°	184°	242°
	N	80°	142°	196°	293°
	A	135°	170°	200°	310°
	B	49°	169°	200°	244°
23 25	C	66°	140°	200°	257°
	D	62°	145°	180°	280°
	E	79°	153°	197°	272°

Dimensions in inches (millimeters) and are subject to change without notice.



240-383P
MIL-DTL-38999 Series III Type Filter Connector
Plug Connector

B

D38999 SERIES III TYPE PLUGS

How To Order										
Sample Part Number	240-383	P	ME	15-35	P	S	P	A	N	N
Filter Connector	MIL-DTL-38999 Series III Type									
Shell Style	P = Plug									
Connector Class	See Table I									
Insert Arrangement	IAW MIL-STD-1560. (See pages B-28 – B-29)									
Contact Gender	P = Pin S = Socket									
Termination	S = Solder Cup									
Filter Type	P = Pi Circuit C = C Circuit (See Note 1)									
Capacitance	See Table II									
Flange Mounting Style	N = Not Applicable									
Alternate Key Position	A, B, C, D, E, N = Normal (See page B-29)									

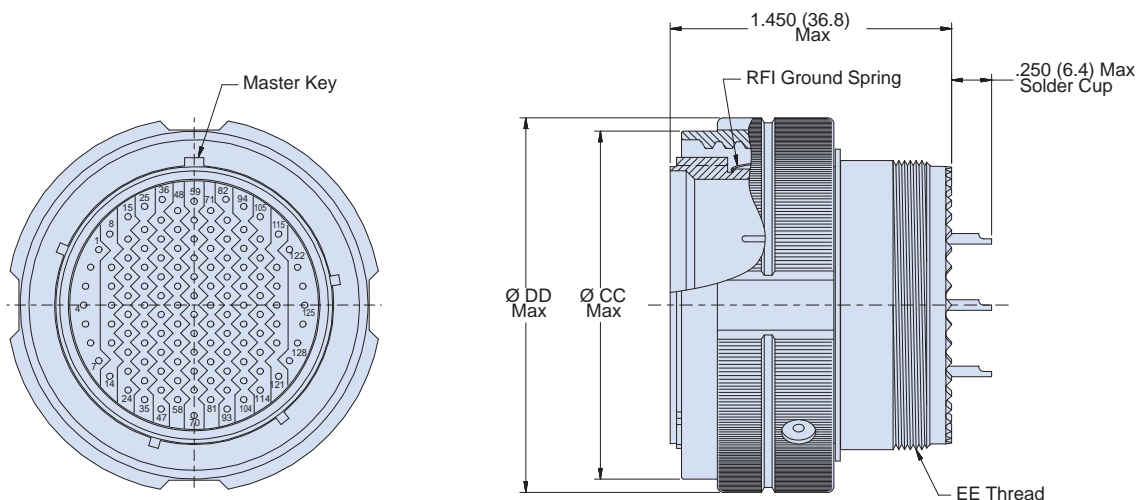

Notes

1. Other filter styles (C-L, L-C, Unbalanced Pi, Multi-Stage, Multi-Value) are available, please consult the factory.

Dimensions in inches (millimeters) and are subject to change without notice.

240-383P
MIL-DTL-38999 Series III Type Filter Connector
Plug Connector



MIL-DTL-38999
Type

B

Sym	Class	Material	Finish Description
ME	Environmental	Aluminum	Electroless Nickel
MT	Environmental	Aluminum	Ni-PTFE 1000 Hour Grey™ Nickel Fluorocarbon Polymer
NF	Environmental	Aluminum	Cadmium O.D. Over Electroless Nickel
ZL	Environmental	Stainless Steel	Electro-Deposited Nickel
XM	Environmental	Composite	Electroless Nickel
XMT	Environmental	Composite	Ni-PTFE 1000 Hour Grey™ Nickel Fluorocarbon Polymer
XW	Environmental	Composite	Cadmium O.D. Over Electroless Nickel
ZN	Environmental	Aluminum	Zinc-Nickel, Olive Drab
ZR	Environmental	Aluminum	Zinc Nickel, Black - RoHS

Class	Pi - Circuit (pF)	C - Circuit (pF)
X*	160,000 - 240,000	80,000 - 120,000
Y*	80,000 - 120,000	40,000 - 60,000
Z*	60,000 - 90,000	30,000 - 45,000
A	38,000 - 56,000	19,000 - 28,000
B	32,000 - 45,000	16,000 - 22,500
C	18,000 - 33,000	9,000 - 16,500
D	8,000 - 12,000	4,000 - 6,000
E	3,300 - 5,000	1,650 - 2,500
F	800 - 1,300	400 - 650
G	400 - 600	200 - 300
J	70-120	35-60

* Filter Classes X, Y and Z are 250 VDC.
All others are 500 VDC

Shell Size	Ø CC Max	Ø DD Max	EE Thread
9	.811 (20.6)	.858 (21.8)	M12 X 1.0-6g 0.100R
11	.929 (23.6)	.984 (25.0)	M15 X 1.0-6g 0.100R
13	1.110 (28.2)	1.157 (29.4)	M18 X 1.0-6g 0.100R
15	1.232 (31.3)	1.280 (32.5)	M22 X 1.0-6g 0.100R
17	1.358 (34.5)	1.406 (35.7)	M25 X 1.0-6g 0.100R
19	1.469 (37.3)	1.516 (38.5)	M28 X 1.0-6g 0.100R
21	1.594 (40.5)	1.642 (41.7)	M31 X 1.0-6g 0.100R
23	1.720 (43.7)	1.768 (44.9)	M34 X 1.0-6g 0.100R
25	1.843 (46.8)	1.890 (48.0)	M37 X 1.0-6g 0.100R

Consult Factory for Additional Filter Types, TVS Diodes, and other Custom Configurations.

Dimensions in inches (millimeters) and are subject to change without notice.

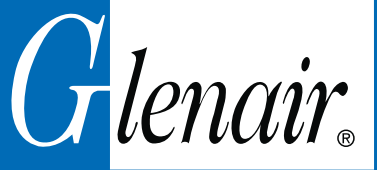

240-383Q
MIL-DTL-38999 Series III Type Filter Connector
Plug with Crimp Removable Contacts

B

D38999 SERIES III TYPE PLUGS WITH CRIMP REMOVABLE CONTACTS

How To Order										
Sample Part Number	240-383	Q	ME	15-35	P	C	P	A	N	N
Filter Connector	MIL-DTL-38999 Series III Type									
Shell Style	Q = Plug with Crimp Contacts									
Connector Class	See Table I									
Insert Arrangement	IAW MIL-STD-1560. (See pages B-28 – B-29)									
Contact Gender	P = Pin S = Socket									
Termination	C = Crimp									
Filter Type	P = Pi Circuit C = C Circuit (See Note 2)									
Capacitance	See Table II									
Flange Mounting Style	N = Not Applicable									
Alternate Key Position	A, B, C, D, E, N = Normal (See page B-29)									

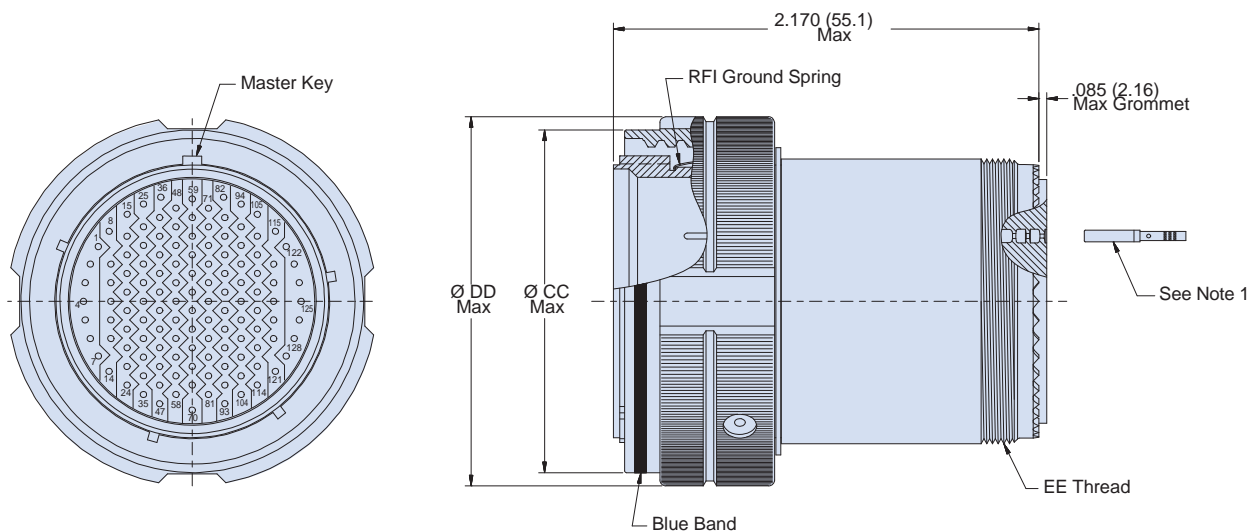

Notes

1. Crimp removable contacts to conform to MIL-C-39029/57-358, Size 16, MIL-C-39029/57-357 Size 20, and MIL-C-39029/57-354 Size 22D (Supplied loose).
2. Other filter styles (C-L, L-C, Unbalanced Pi, Multi-Stage, Multi-Value) are available, please consult the factory.

Dimensions in inches (millimeters) and are subject to change without notice.

240-383Q
MIL-DTL-38999 Series III Type Filter Connector
Plug with Crimp Removable Contacts



MIL-DTL-38999
Type

B

Table I: Connector Class			
Sym	Class	Material	Finish Description
ME	Environmental	Aluminum	Electroless Nickel
MT	Environmental	Aluminum	Ni-PTFE 1000 Hour Grey™ Nickel Fluorocarbon Polymer
NF	Environmental	Aluminum	Cadmium O.D. Over Electroless Nickel
ZL	Environmental	Stainless Steel	Electro-Deposited Nickel
XM	Environmental	Composite	Electroless Nickel
XMT	Environmental	Composite	Ni-PTFE 1000 Hour Grey™ Nickel Fluorocarbon Polymer
XW	Environmental	Composite	Cadmium O.D. Over Electroless Nickel
ZN	Environmental	Aluminum	Zinc-Nickel, Olive Drab
ZR	Environmental	Aluminum	Zinc Nickel, Black - RoHS

Table II: Capacitor Array Code Capacitance Range		
Class	Pi - Circuit (pF)	C - Circuit (pF)
X*	160,000 - 240,000	80,000 - 120,000
Y*	80,000 - 120,000	40,000 - 60,000
Z*	60,000 - 90,000	30,000 - 45,000
A	38,000 - 56,000	19,000 - 28,000
B	32,000 - 45,000	16,000 - 22,500
C	18,000 - 33,000	9,000 - 16,500
D	8,000 - 12,000	4,000 - 6,000
E	3,300 - 5,000	1,650 - 2,500
F	800 - 1,300	400 - 650
G	400 - 600	200 - 300
J	70-120	35-60

* Filter Classes X, Y and Z are 250 VDC.
 All others are 500 VDC

Table III: Dimensions			
Shell Size	Ø CC Max	Ø DD Max	EE Thread
9	.811 (20.6)	.858 (21.8)	M12 X 1.0-6g 0.100R
11	.929 (23.6)	.984 (25.0)	M15 X 1.0-6g 0.100R
13	1.110 (28.2)	1.157 (29.4)	M18 X 1.0-6g 0.100R
15	1.232 (31.3)	1.280 (32.5)	M22 X 1.0-6g 0.100R
17	1.358 (34.5)	1.406 (35.7)	M25 X 1.0-6g 0.100R
19	1.469 (37.3)	1.516 (38.5)	M28 X 1.0-6g 0.100R
21	1.594 (40.5)	1.642 (41.7)	M31 X 1.0-6g 0.100R
23	1.720 (43.7)	1.768 (44.9)	M34 X 1.0-6g 0.100R
25	1.843 (46.8)	1.890 (48.0)	M37 X 1.0-6g 0.100R

Consult Factory for Additional Filter Types, TVS Diodes, and other Custom Configurations.

Dimensions in inches (millimeters) and are subject to change without notice.

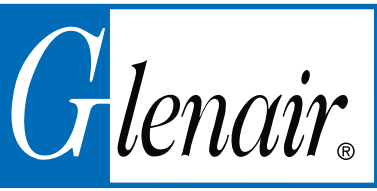

240-383W
MIL-DTL-38999 Series III Type Filter Connector
Wall Mount Receptacle

B

D38999 SERIES III TYPE WALL MOUNT RECEPTACLE

How To Order										
Sample Part Number	240-383	W	ME	15-35	P	S	P	A	C	N
Filter Connector	MIL-DTL-38999 Series III Type									
Shell Style	W = Wall Mount									
Connector Class	See Table I									
Insert Arrangement	IAW MIL-STD-1560. (See pages B-28 - B-29)									
Contact Gender	P = Pin S = Socket									
Termination	S = Solder Cup P = PC Tail									
Filter Type	P = Pi Circuit C = C Circuit (See Note 1)									
Capacitance	See Table II									
Flange Mounting Style	H = Round Holes C = Clinch Nuts (4-40 UNC) [†] M = Metric Clinch Nuts (M3) [†] S = Slotted Holes									
Alternate Key Position	A, B, C, D, E, N = Normal (See page B-29)									

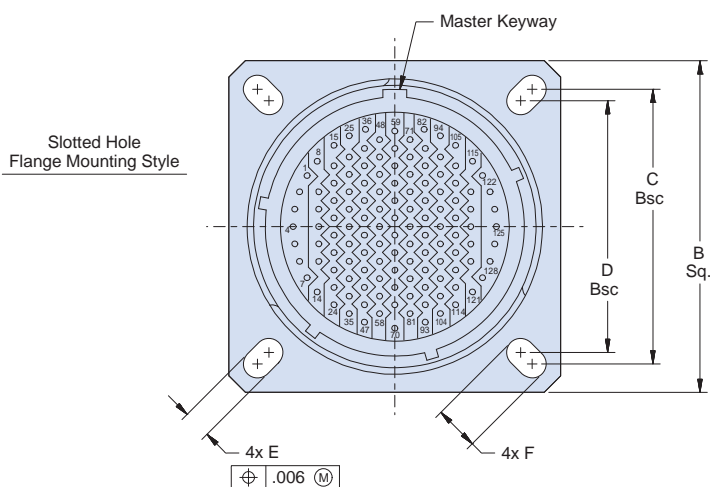
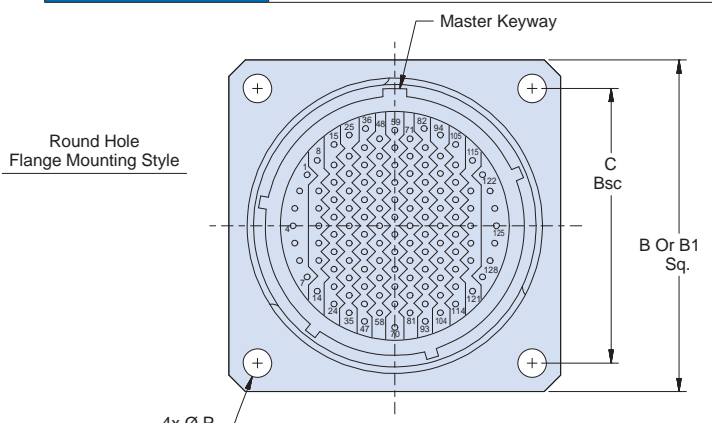

Notes

1. Other filter styles (C-L, L-C, Unbalanced Pi, Multi-Stage, Multi-Value) are available, please consult the factory.
2. Consult factory for alternate PC Tail lengths
3. Helicoil and threaded inserts/specials available upon request.

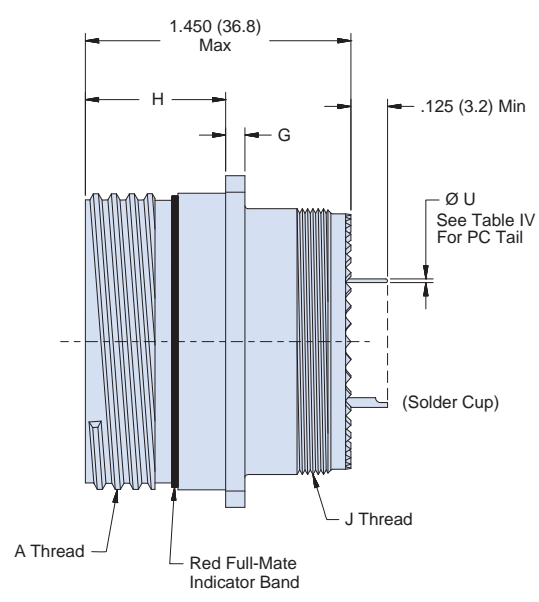

Dimensions in inches (millimeters) and are subject to change without notice.

240-383W
MIL-DTL-38999 Series III Type Filter Connector
Wall Mount Receptacle



MIL-DTL-38999
Type

B

Sym	Class	Material	Finish Description
ME	Environmental	Aluminum	Electroless Nickel
MT	Environmental	Aluminum	Ni-PTFE 1000 Hour Grey™ Nickel Fluorocarbon Polymer
NF	Environmental	Aluminum	Cadmium O.D. Over Electroless Nickel
ZL	Environmental	Stainless Steel	Electro-Deposited Nickel
XM†	Environmental	Composite	Electroless Nickel
XMT†	Environmental	Composite	Ni-PTFE 1000 Hour Grey™ Nickel Fluorocarbon Polymer
XW†	Environmental	Composite	Cadmium O.D. Over Electroless Nickel
ZN	Environmental	Aluminum	Zinc-Nickel, Olive Drab
ZR	Environmental	Aluminum	Zinc Nickel, Black - RoHS
H2*	Hermetic	Stainless Steel	Electro-Deposited Nickel

*Some dimensions do not apply. See drawing 240-383WH2
†Clinch nuts and metric clinch nuts not available for composites.

Class	Pi - Circuit (pF)	C - Circuit (pF)
X*	160,000 - 240,000	80,000 - 120,000
Y*	80,000 - 120,000	40,000 - 60,000
Z*	60,000 - 90,000	30,000 - 45,000
A	38,000 - 56,000	19,000 - 28,000
B	32,000 - 45,000	16,000 - 22,500
C	18,000 - 33,000	9,000 - 16,500
D	8,000 - 12,000	4,000 - 6,000
E	3,300 - 5,000	1,650 - 2,500
F	800 - 1,300	400 - 650
G	400 - 600	200 - 300
J	70-120	35-60

* Filter Classes X, Y and Z are 250 VDC. All others are 500 VDC

Contact Size	Ø U
22D	.021 (0.53)
	.018 (0.46)
20	.031 (0.79)
	.029 (0.74)
16	.042 (1.07)
	.038 (0.97)
12	.096 (2.44)
	.092 (2.34)

Shell Size	A Thread	Thru Hole Flange		Clinch Nut Flange	Slotted Hole Flange				G	H	J Thread
		B Sq.	Ø P ±.010 (.25)	B1 Sq. ±.020 (.51)	C Bsc	D Bsc	E	F			
9	.6250-1P-.3L-TS-2A	.949 (24.1) .925 (23.5)	.128 (3.3)	1.019 (25.9)	.719 (18.3)	.594 (15.1)	.136 (3.5) .120 (3.0)	.224 (5.7) .208 (5.3)	.144 (3.7) .083 (2.1)	.820 (20.8) .771 (19.6)	M12 X 1.0-6g 0.100R
11	.7500-1P-.3L-TS-2A	1.043 (26.5) 1.019 (25.9)	.128 (3.3)	1.112 (28.2)	.812 (20.6)	.719 (18.3)	.136 (3.5) .120 (3.0)	.202 (5.1) .186 (4.7)	.144 (3.7) .083 (2.1)	.820 (20.8) .771 (19.6)	M15 X 1.0-6g 0.100R
13	.8750-1P-.3L-TS-2A	1.138 (28.9) 1.114 (28.3)	.128 (3.3)	1.206 (30.6)	.906 (23.0)	.812 (20.6)	.136 (3.5) .120 (3.0)	.202 (5.1) .186 (4.7)	.144 (3.7) .083 (2.1)	.820 (20.8) .771 (19.6)	M18 X 1.0-6g 0.100R
15	1.0000-1P-.3L-TS-2A	1.232 (31.3) 1.208 (30.7)	.128 (3.3)	1.269 (32.2)	.969 (24.6)	.906 (23.0)	.136 (3.5) .120 (3.0)	.181 (4.6) .165 (4.2)	.144 (3.7) .083 (2.1)	.820 (20.8) .771 (19.6)	M22 X 1.0-6g 0.100R
17	1.1875-1P-.3L-TS-2A	1.323 (33.6) 1.299 (33.0)	.128 (3.3)	1.362 (34.6)	1.062 (27.0)	.969 (24.6)	.136 (3.5) .120 (3.0)	.202 (5.1) .186 (4.7)	.144 (3.7) .083 (2.1)	.820 (20.8) .771 (19.6)	M25 X 1.0-6g 0.100R
19	1.2500-1P-.3L-TS-2A	1.449 (36.8) 1.425 (36.2)	.128 (3.3)	1.456 (37.0)	1.156 (29.4)	1.062 (27.0)	.136 (3.5) .120 (3.0)	.202 (5.1) .186 (4.7)	.144 (3.7) .083 (2.1)	.820 (20.8) .771 (19.6)	M28 X 1.0-6g 0.100R
21	1.3750-1P-.3L-TS-2A	1.575 (40.0) 1.551 (39.4)	.128 (3.3)	1.562 (39.7)	1.250 (31.8)	1.156 (29.4)	.136 (3.5) .120 (3.0)	.202 (5.1) .186 (4.7)	.171 (4.3) .083 (2.1)	.790 (20.1) .741 (18.8)	M31 X 1.0-6g 0.100R
23	1.5000-1P-.3L-TS-2A	1.701 (43.2) 1.677 (42.6)	.156 (4.0)	1.719 (43.7)	1.375 (34.9)	1.250 (31.8)	.162 (4.1) .146 (3.7)	.250 (6.4) .234 (5.9)	.171 (4.3) .083 (2.1)	.790 (20.1) .741 (18.8)	M34 X 1.0-6g 0.100R
25	1.6250-1P-.3L-TS-2A	1.823 (46.3) 1.799 (45.7)	.156 (4.0)	1.844 (46.8)	1.500 (38.1)	1.375 (34.9)	.162 (4.1) .146 (3.7)	.250 (6.4) .234 (5.9)	.171 (4.3) .083 (2.1)	.790 (20.1) .741 (18.8)	M37 X 1.0-6g 0.100R

Dimensions in inches (millimeters) and are subject to change without notice.



240-383J MIL-DTL-38999 Series III Type Filter Connector Jam Nut Receptacle

B

D38999 SERIES III TYPE JAM NUT RECEPTACLE

How To Order										
Sample Part Number	240-383	J	ME	15-35	P	S	P	A	N	N
Filter Connector	MIL-DTL-38999 Series III Type									
Shell Style	J = Jam Nut									
Connector Class	See Table I									
Insert Arrangement	IAW MIL-STD-1560. (See pages B-28 – B-29)									
Contact Gender	P = Pin S = Socket									
Termination	S = Solder Cup P = PC Tail									
Filter Type	P = Pi Circuit C = C Circuit (See Note 1)									
Capacitance	See Table II									
Flange Mounting Style	N = Not Applicable									
Alternate Key Position	A, B, C, D, E, N = Normal (See page B-29)									

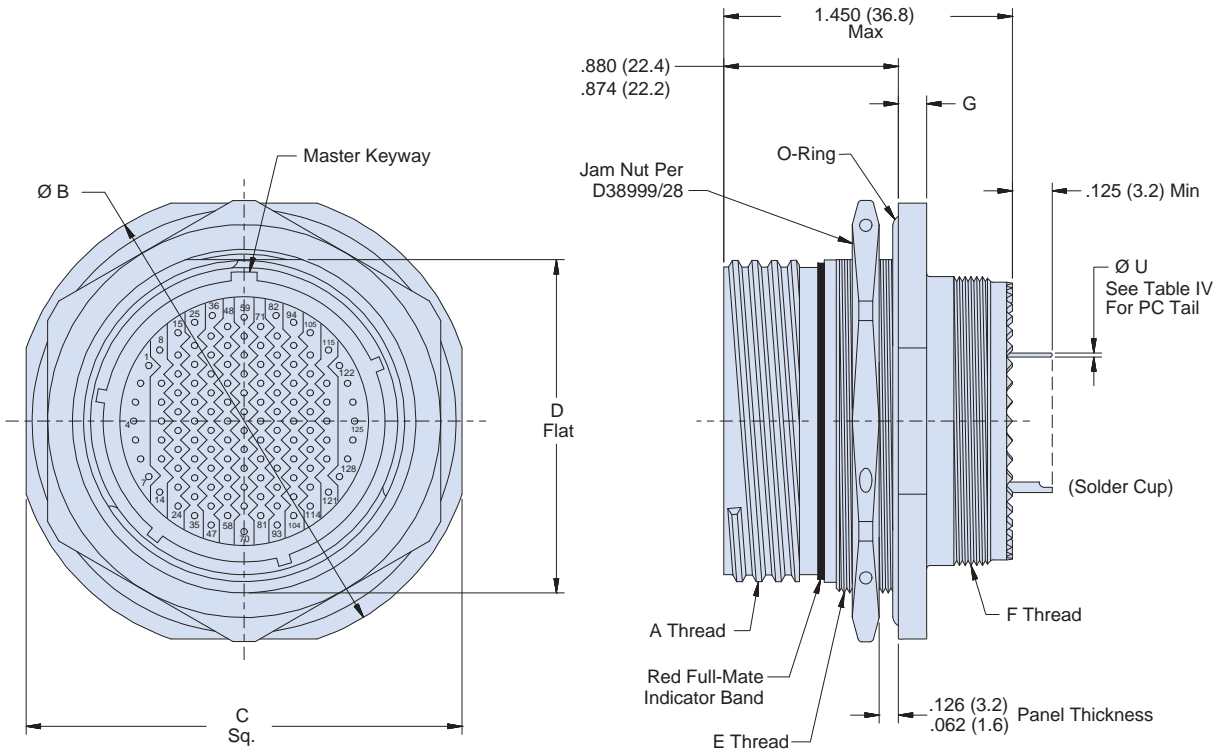

Notes
1. Other filter styles (C-L, L-C, Unbalanced Pi, Multi-Stage, Multi-Value) are available, please consult the factory.

Dimensions in inches (millimeters) and are subject to change without notice.

© 2013 Glenair, Inc. U.S. CAGE Code 06324 Printed in U.S.A.

240-383J
MIL-DTL-38999 Series III Type Filter Connector
Jam Nut Receptacle



MIL-DTL-38999
Type

B

Sym	Class	Material	Finish Description
ME	Environmental	Aluminum	Electroless Nickel
MT	Environmental	Aluminum	Ni-PTFE 1000 Hour Grey™ Nickel Fluorocarbon Polymer
NF	Environmental	Aluminum	Cadmium O.D. Over Electroless Nickel
ZL	Environmental	Stainless Steel	Electro-Deposited Nickel
XM	Environmental	Composite	Electroless Nickel
XMT	Environmental	Composite	Ni-PTFE 1000 Hour Grey™ Nickel Fluorocarbon Polymer
XW	Environmental	Composite	Cadmium O.D. Over Electroless Nickel
ZN	Environmental	Aluminum	Zinc-Nickel, Olive Drab
ZR	Environmental	Aluminum	Zinc Nickel, Black - RoHS
H2*	Hermetic	Stainless Steel	Electro-Deposited Nickel

*Some dimensions do not apply. See drawing 240-383JH2

Class	Pi - Circuit (pF)	C - Circuit (pF)
X*	160,000 - 240,000	80,000 - 120,000
Y*	80,000 - 120,000	40,000 - 60,000
Z*	60,000 - 90,000	30,000 - 45,000
A	38,000 - 56,000	19,000 - 28,000
B	32,000 - 45,000	16,000 - 22,500
C	18,000 - 33,000	9,000 - 16,500
D	8,000 - 12,000	4,000 - 6,000
E	3,300 - 5,000	1,650 - 2,500
F	800 - 1,300	400 - 650
G	400 - 600	200 - 300
J	70-120	35-60

* Filter Classes X, Y and Z are 250 VDC. All others are 500 VDC

Contact Size	Ø U
22D	.021 (0.53)
	.018 (0.46)
20	.031 (0.79)
	.029 (0.74)
16	.042 (1.07)
	.038 (0.97)
12	.096 (2.44)
	.092 (2.34)

Shell Size	A Thread	Ø B	C Sq.	D Flat	E Thread	F Thread	G
9	.6250-.1P-.3L-TS-2A	1.201 (30.5)	1.079 (27.4)	.655 (16.6)	M17 X 1.0-6g 0.100R	M12 X 1.0-6g 0.100R	.122 (3.1)
		1.177 (29.9)	1.047 (26.6)	.645 (16.4)			.083 (2.1)
11	.7500-.1P-.3L-TS-2A	1.386 (35.2)	1.268 (32.2)	.755 (19.2)	M20 X 1.0-6g 0.100R	M15 X 1.0-6g 0.100R	.122 (3.1)
		1.362 (34.6)	1.236 (31.4)	.745 (18.9)			.083 (2.1)
13	.8750-.1P-.3L-TS-2A	1.512 (38.4)	1.390 (35.3)	.942 (23.9)	M25 X 1.0-6g 0.100R	M18 X 1.0-6g 0.100R	.122 (3.1)
		1.488 (37.8)	1.358 (34.5)	.932 (23.7)			.083 (2.1)
15	1.000-.1P-.3L-TS-2A	1.638 (41.6)	1.516 (38.5)	1.066 (27.1)	M28 X 1.0-6g 0.100R	M22 X 1.0-6g 0.100R	.122 (3.1)
		1.614 (41.0)	1.484 (37.7)	1.056 (26.8)			.083 (2.1)
17	1.1875-.1P-.3L-TS-2A	1.764 (44.8)	1.642 (41.7)	1.191 (30.3)	M32 X 1.0-6g 0.100R	M25 X 1.0-6g 0.100R	.122 (3.1)
		1.740 (44.2)	1.610 (40.9)	1.181 (30.0)			.083 (2.1)
19	1.2500-.1P-.3L-TS-2A	1.949 (49.5)	1.827 (46.4)	1.316 (33.4)	M35 X 1.0-6g 0.100R	M28 X 1.0-6g 0.100R	.154 (3.9)
		1.925 (48.9)	1.795 (45.6)	1.306 (33.2)			.114 (2.9)
21	1.3750-.1P-.3L-TS-2A	2.075 (52.7)	1.953 (49.6)	1.441 (36.6)	M38 X 1.0-6g 0.100R	M31 X 1.0-6g 0.100R	.154 (3.9)
		2.051 (52.1)	1.921 (48.8)	1.431 (36.3)			.114 (2.9)
23	1.5000-.1P-.3L-TS-2A	2.201 (55.9)	2.079 (52.8)	1.566 (39.8)	M41 X 1.0-6g 0.100R	M34 X 1.0-6g 0.100R	.154 (3.9)
		2.177 (55.3)	2.047 (52.0)	1.556 (39.5)			.114 (2.9)
25	1.6250-.1P-.3L-TS-2A	2.323 (59.0)	2.205 (56.0)	1.691 (43.0)	M44 X 1.0-6g 0.100R	M37 X 1.0-6g 0.100R	.154 (3.9)
		2.299 (58.4)	2.173 (55.2)	1.681 (42.7)			.114 (2.9)

Consult Factory for Additional Filter Types, TVS Diodes, and other Custom Configurations.

Dimensions in inches (millimeters) and are subject to change without notice.

D38999 SERIES III TYPE WALL MOUNT RECEPTACLE WITH CRIMP REMOVABLE CONTACTS

How To Order										
Sample Part Number	240-383	R	ME	15-35	P	C	P	A	C	N
Filter Connector	MIL-DTL-38999 Series III Type									
Shell Style	R = Wall Mount with Crimp Contacts									
Connector Class	See Table I									
Insert Arrangement	IAW MIL-STD-1560. (See pages B-28 – B-29)									
Contact Gender	P = Pin S = Socket									
Termination	C = Crimp									
Filter Type	P = Pi Circuit C = C Circuit (See Note 2)									
Capacitance	See Table II									
Flange Mounting Style	H = Round Holes C = Clinch Nuts (4-40 UNC) [†] M = Metric Clinch Nuts (M3) [†] S = Slotted Holes									
Alternate Key Position	A, B, C, D, E, N = Normal (See page B-29)									

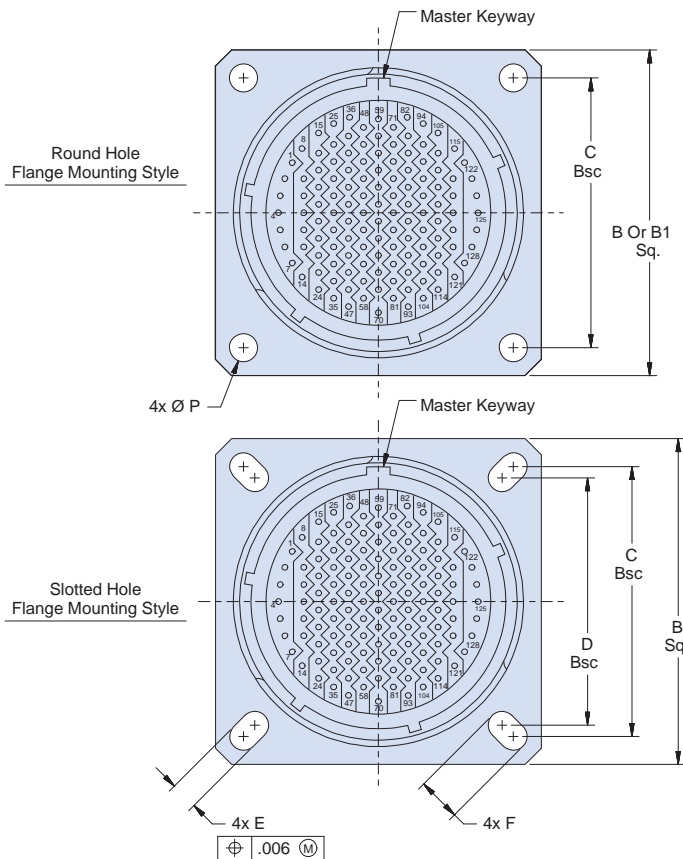

Notes

1. Crimp removable contacts to conform to MIL-C-39029/57-358, Size 16, MIL-C-39029/57-357 Size 20, and MIL-C-39029/57-354 Size 22D (Supplied loose).
2. Other filter styles (C-L, L-C, Unbalanced Pi, Multi-Stage, Multi-Value) are available, please consult the factory.
3. Helicoil and threaded inserts/specials available upon request.

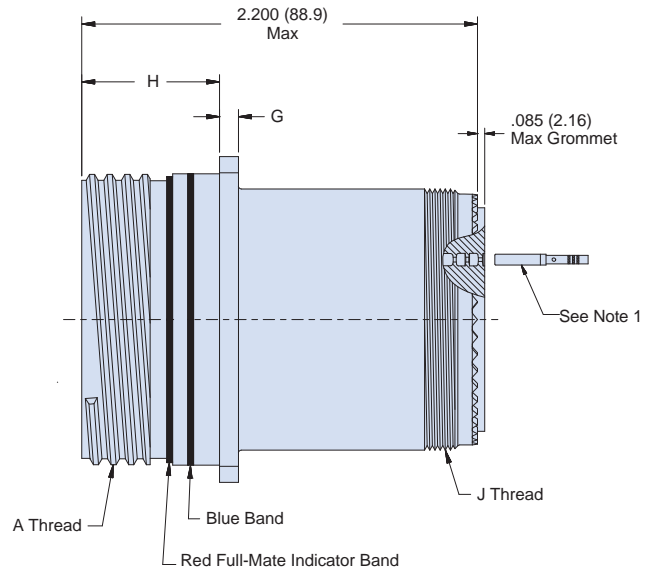

Dimensions in inches (millimeters) and are subject to change without notice.

240-383R
MIL-DTL-38999 Series III Type Filter Connector
Wall Mount Receptacle with Crimp Removable Contacts



MIL-DTL-38999
Type

B

Table I: Connector Class

Sym	Class	Material	Finish Description
ME	Environmental	Aluminum	Electroless Nickel
MT	Environmental	Aluminum	Ni-PTFE 1000 Hour Grey™ Nickel Fluorocarbon Polymer
NF	Environmental	Aluminum	Cadmium O.D. Over Electroless Nickel
ZL	Environmental	Stainless Steel	Electro-Deposited Nickel
XM†	Environmental	Composite	Electroless Nickel
XMT†	Environmental	Composite	Ni-PTFE 1000 Hour Grey™ Nickel Fluorocarbon Polymer
XW†	Environmental	Composite	Cadmium O.D. Over Electroless Nickel
ZN	Environmental	Aluminum	Zinc-Nickel, Olive Drab
ZR	Environmental	Aluminum	Zinc Nickel, Black - RoHS
H2*	Hermetic	Stainless Steel	Electro-Deposited Nickel

*Some dimensions do not apply. See drawing 240-383RH2
 † Clinch nuts and metric clinch nuts not available for composites.

Table II: Capacitor Array Code Capacitance Range

Class	Pi - Circuit (pF)	C - Circuit (pF)
X*	160,000 - 240,000	80,000 - 120,000
Y*	80,000 - 120,000	40,000 - 60,000
Z*	60,000 - 90,000	30,000 - 45,000
A	38,000 - 56,000	19,000 - 28,000
B	32,000 - 45,000	16,000 - 22,500
C	18,000 - 33,000	9,000 - 16,500
D	8,000 - 12,000	4,000 - 6,000
E	3,300 - 5,000	1,650 - 2,500
F	800 - 1,300	400 - 650
G	400 - 600	200 - 300
J	70-120	35-60

* Filter Classes X, Y and Z are 250 VDC. All others are 500 VDC

Consult Factory for Additional Filter Types, TVS Diodes, and other Custom Configurations.

Table III: Dimensions

Shell Size	A Thread	Thru Hole Flange		Clinch Nut Flange	Slotted Hole Flange				G	H	J Thread
		B Sq.	Ø P ±.010 (.25)	B1 Sq. ±.020 (.51)	C Bsc	D Bsc	E	F			
9	.6250-1P-3L-TS-2A	.949 (24.1) .925 (23.5)	.128 (3.3)	1.019 (25.9)	.719 (18.3)	.594 (15.1)	.136 (3.5) .120 (3.0)	.224 (5.7) .208 (5.3)	.144 (3.7) .083 (2.1)	.820 (20.8) .771 (19.6)	M12 X 1.0-6g 0.100R
11	.7500-1P-3L-TS-2A	1.043 (26.5) 1.019 (25.9)	.128 (3.3)	1.112 (28.2)	.812 (20.6)	.719 (18.3)	.136 (3.5) .120 (3.0)	.202 (5.1) .186 (4.7)	.144 (3.7) .083 (2.1)	.820 (20.8) .771 (19.6)	M15 X 1.0-6g 0.100R
13	.8750-1P-3L-TS-2A	1.138 (28.9) 1.114 (28.3)	.128 (3.3)	1.206 (30.6)	.906 (23.0)	.812 (20.6)	.136 (3.5) .120 (3.0)	.202 (5.1) .186 (4.7)	.144 (3.7) .083 (2.1)	.820 (20.8) .771 (19.6)	M18 X 1.0-6g 0.100R
15	1.0000-1P-3L-TS-2A	1.232 (31.3) 1.208 (30.7)	.128 (3.3)	1.269 (32.2)	.969 (24.6)	.906 (23.0)	.136 (3.5) .120 (3.0)	.181 (4.6) .165 (4.2)	.144 (3.7) .083 (2.1)	.820 (20.8) .771 (19.6)	M22 X 1.0-6g 0.100R
17	1.1875-1P-3L-TS-2A	1.323 (33.6) 1.299 (33.0)	.128 (3.3)	1.362 (34.6)	1.062 (27.0)	.969 (24.6)	.136 (3.5) .120 (3.0)	.202 (5.1) .186 (4.7)	.144 (3.7) .083 (2.1)	.820 (20.8) .771 (19.6)	M25 X 1.0-6g 0.100R
19	1.2500-1P-3L-TS-2A	1.449 (36.8) 1.425 (36.2)	.128 (3.3)	1.456 (37.0)	1.156 (29.4)	1.062 (27.0)	.136 (3.5) .120 (3.0)	.202 (5.1) .186 (4.7)	.144 (3.7) .083 (2.1)	.820 (20.8) .771 (19.6)	M28 X 1.0-6g 0.100R
21	1.3750-1P-3L-TS-2A	1.575 (40.0) 1.551 (39.4)	.128 (3.3)	1.562 (39.7)	1.250 (31.8)	1.156 (29.4)	.136 (3.5) .120 (3.0)	.202 (5.1) .186 (4.7)	.171 (4.3) .083 (2.1)	.790 (20.1) .741 (18.8)	M31 X 1.0-6g 0.100R
23	1.5000-1P-3L-TS-2A	1.701 (43.2) 1.677 (42.6)	.156 (4.0)	1.719 (43.7)	1.375 (34.9)	1.250 (31.8)	.162 (4.1) .146 (3.7)	.250 (6.4) .234 (5.9)	.171 (4.3) .083 (2.1)	.790 (20.1) .741 (18.8)	M34 X 1.0-6g 0.100R
25	1.6250-1P-3L-TS-2A	1.823 (46.3) 1.799 (45.7)	.156 (4.0)	1.844 (46.8)	1.500 (38.1)	1.375 (34.9)	.162 (4.1) .146 (3.7)	.250 (6.4) .234 (5.9)	.171 (4.3) .083 (2.1)	.790 (20.1) .741 (18.8)	M37 X 1.0-6g 0.100R

Dimensions in inches (millimeters) and are subject to change without notice.

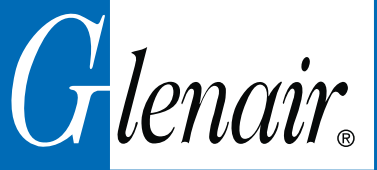

240-383S
MIL-DTL-38999 Series III Type Filter Connector
Jam Nut Receptacle with Crimp Removable Contacts

D38999 SERIES III TYPE JAM NUT RECEPTACLE WITH CRIMP REMOVABLE CONTACTS

B

How To Order										
Sample Part Number	240-383	S	ME	15-35	P	C	P	A	N	N
Filter Connector	MIL-DTL-38999 Series III Type									
Shell Style	S = Jam Nut with Crimp Contacts									
Connector Class	See Table I									
Insert Arrangement	IAW MIL-STD-1560. (See pages B-28 – B-29)									
Contact Gender	P = Pin S = Socket									
Termination	C = Crimp									
Filter Type	P = Pi Circuit C = C Circuit (See Note 2)									
Capacitance	See Table II									
Flange Mounting Style	N = Not Applicable									
Alternate Key Position	A, B, C, D, E, N = Normal (See page B-29)									

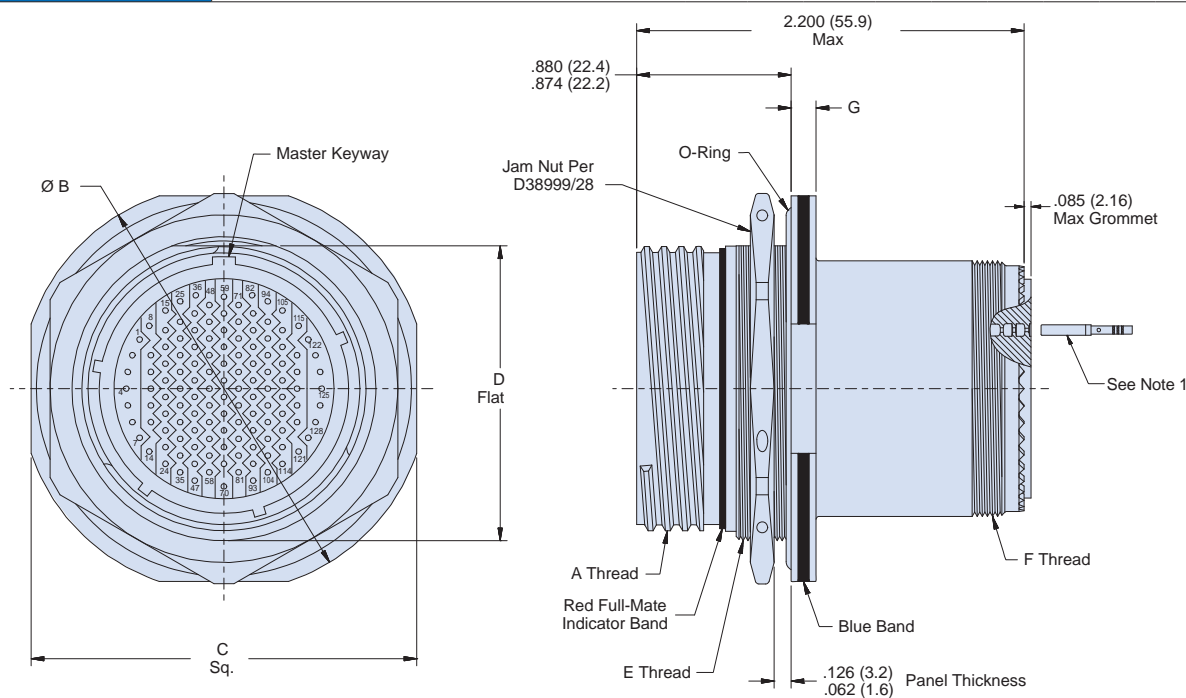

Notes

1. Crimp removable contacts to conform to MIL-C-39029/57-358, Size 16, MIL-C-39029/57-357 Size 20, and MIL-C-39029/57-354 Size 22D (Supplied loose).
2. Other filter styles (C-L, L-C, Unbalanced Pi, Multi-Stage, Multi-Value) are available, please consult the factory.

Dimensions in inches (millimeters) and are subject to change without notice.

240-383S
MIL-DTL-38999 Series III Type Filter Connector
Jam Nut Receptacle with Crimp Removable Contacts



MIL-DTL-38999
Type

B

Table I: Connector Class			
Sym	Class	Material	Finish Description
ME	Environmental	Aluminum	Electroless Nickel
MT	Environmental	Aluminum	Ni-PTFE 1000 Hour Grey™ Nickel Fluorocarbon Polymer
NF	Environmental	Aluminum	Cadmium O.D. Over Electroless Nickel
ZL	Environmental	Stainless Steel	Electro-Deposited Nickel
XM	Environmental	Composite	Electroless Nickel
XMT	Environmental	Composite	Ni-PTFE 1000 Hour Grey™ Nickel Fluorocarbon Polymer
XW	Environmental	Composite	Cadmium O.D. Over Electroless Nickel
ZN	Environmental	Aluminum	Zinc-Nickel, Olive Drab
ZR	Environmental	Aluminum	Zinc Nickel, Black - RoHS
H2*	Hermetic	Stainless Steel	Electro-Deposited Nickel

*Some dimensions do not apply. See drawing 240-383SH2

Table II: Capacitor Array Code Capacitance Range		
Class	Pi - Circuit (pF)	C - Circuit (pF)
X*	160,000 - 240,000	80,000 - 120,000
Y*	80,000 - 120,000	40,000 - 60,000
Z*	60,000 - 90,000	30,000 - 45,000
A	38,000 - 56,000	19,000 - 28,000
B	32,000 - 45,000	16,000 - 22,500
C	18,000 - 33,000	9,000 - 16,500
D	8,000 - 12,000	4,000 - 6,000
E	3,300 - 5,000	1,650 - 2,500
F	800 - 1,300	400 - 650
G	400 - 600	200 - 300
J	70-120	35-60

* Filter Classes X, Y and Z are 250 VDC. All others are 500 VDC

Consult Factory for Additional Filter Types, TVS Diodes, and other Custom Configurations.

Table III: Dimensions							
Shell Size	A Thread	Ø B	C	D	E Thread	F Thread	G
9	.6250- .1P- .3L-TS-2A	1.201 (30.5) 1.177 (29.9)	1.079 (27.4) 1.047 (26.6)	.655 (16.6) .645 (16.4)	M17 X 1.0-6g 0.100R	M12 X 1.0-6g 0.100R	.122 (3.1) .083 (2.1)
11	.7500- .1P- .3L-TS-2A	1.386 (35.2) 1.362 (34.6)	1.268 (32.2) 1.236 (31.4)	.755 (19.2) .745 (18.9)	M20 X 1.0-6g 0.100R	M15 X 1.0-6g 0.100R	.122 (3.1) .083 (2.1)
13	.8750- .1P- .3L-TS-2A	1.512 (38.4) 1.488 (37.8)	1.390 (35.3) 1.358 (34.5)	.942 (23.9) .932 (23.7)	M25 X 1.0-6g 0.100R	M18 X 1.0-6g 0.100R	.122 (3.1) .083 (2.1)
15	1.000- .1P- .3L-TS-2A	1.638 (41.6) 1.614 (41.0)	1.516 (38.5) 1.484 (37.7)	1.066 (27.1) 1.056 (26.9)	M28 X 1.0-6g 0.100R	M22 X 1.0-6g 0.100R	.122 (3.1) .083 (2.1)
17	1.1875- .1P- .3L-TS-2A	1.764 (44.8) 1.740 (44.2)	1.642 (41.7) 1.610 (40.9)	1.191 (30.3) 1.181 (30.0)	M32 X 1.0-6g 0.100R	M25 X 1.0-6g 0.100R	.122 (3.1) .083 (2.1)
19	1.2500- .1P- .3L-TS-2A	1.949 (49.5) 1.925 (48.9)	1.827 (46.4) 1.795 (45.6)	1.316 (33.4) 1.306 (33.2)	M35 X 1.0-6g 0.100R	M28 X 1.0-6g 0.100R	.154 (3.9) .114 (2.9)
21	1.3750- .1P- .3L-TS-2A	2.075 (52.7) 2.051 (52.1)	1.953 (49.6) 1.921 (48.8)	1.441 (36.6) 1.431 (36.3)	M38 X 1.0-6g 0.100R	M31 X 1.0-6g 0.100R	.154 (3.9) .114 (2.9)
23	1.5000- .1P- .3L-TS-2A	2.201 (55.9) 2.177 (55.3)	2.079 (52.8) 2.047 (52.0)	1.566 (39.8) 1.556 (39.5)	M41 X 1.0-6g 0.100R	M34 X 1.0-6g 0.100R	.154 (3.9) .114 (2.9)
25	1.6250- .1P- .3L-TS-2A	2.323 (59.0) 2.299 (58.4)	2.205 (56.0) 2.173 (55.2)	1.691 (43.0) 1.681 (42.7)	M44 X 1.0-6g 0.100R	M37 X 1.0-6g 0.100R	.154 (3.9) .114 (2.9)

Dimensions in inches (millimeters) and are subject to change without notice.

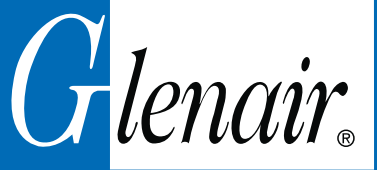

240-383D
MIL-DTL-38999 Series III Type Filter Connector
Dual Flange Wall Mount Receptacle with PC Tails

D38999 SERIES III TYPE DUAL FLANGE WALL MOUNT RECEPTACLE WITH PC TAILS

B

How To Order										
Sample Part Number	240-383	D	ME	15-35	P	P	P	A	N	N
Filter Connector	MIL-DTL-38999 Series III Type									
Shell Style	D = Dual Flange Wall Mount									
Connector Class	See Table I									
Insert Arrangement	IAW MIL-STD-1560. (See pages B-28 – B-29)									
Contact Gender	P = Pin S = Socket									
Termination	P = PC Tail									
Filter Type	P = Pi Circuit C = C Circuit (See Note 1)									
Capacitance	See Table II									
Flange Mounting Style	N = Not Applicable									
Alternate Key Position	A, B, C, D, E, N = Normal (See page B-29)									

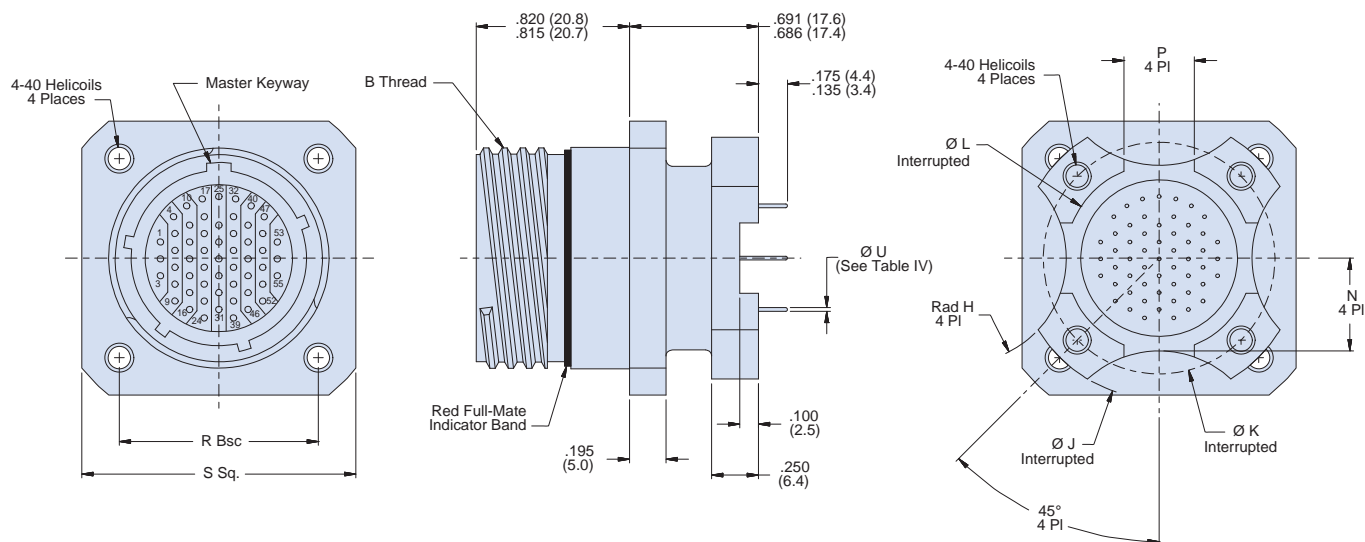

Notes

1. Other filter styles (C-L, L-C, Unbalanced Pi, Multi-Stage, Multi-Value) are available, please consult the factory.

Dimensions in inches (millimeters) and are subject to change without notice.

240-383D
MIL-DTL-38999 Series III Type Filter Connector
Dual Flange Wall Mount Receptacle with PC Tails



MIL-DTL-38999
Type

B

Table I: Connector Class

Sym	Class	Material	Finish Description
ME	Environmental	Aluminum	Electroless Nickel
MT	Environmental	Aluminum	Ni-PTFE 1000 Hour Grey™ Nickel Fluorocarbon Polymer
NF	Environmental	Aluminum	Cadmium O.D. Over Electroless Nickel
ZL	Environmental	Stainless Steel	Electro-Deposited Nickel
XM	Environmental	Composite	Electroless Nickel
XMT	Environmental	Composite	Ni-PTFE 1000 Hour Grey™ Nickel Fluorocarbon Polymer
XW	Environmental	Composite	Cadmium O.D. Over Electroless Nickel
ZN	Environmental	Aluminum	Zinc-Nickel, Olive Drab
ZR	Environmental	Aluminum	Zinc Nickel, Black - RoHS
H2*	Hermetic	Stainless Steel	Electro-Deposited Nickel

*Some dimensions do not apply. See drawing 240-383DH2

Table II: Capacitor Array Code Capacitance Range

Class	Pi - Circuit (pF)	C - Circuit (pF)
X*	160,000 - 240,000	80,000 - 120,000
Y*	80,000 - 120,000	40,000 - 60,000
Z*	60,000 - 90,000	30,000 - 45,000
A	38,000 - 56,000	19,000 - 28,000
B	32,000 - 45,000	16,000 - 22,500
C	18,000 - 33,000	9,000 - 16,500
D	8,000 - 12,000	4,000 - 6,000
E	3,300 - 5,000	1,650 - 2,500
F	800 - 1,300	400 - 650
G	400 - 600	200 - 300
J	70-120	35-60

* Filter Classes X, Y and Z are 250 VDC.
All others are 500 VDC

Table IV: PC Tail Dia

Contact Size	Ø U
22D	.021 (0.53)
	.018 (0.46)
20	.031 (0.79)
	.029 (0.74)
16	.042 (1.07)
	.038 (0.97)
12	.096 (2.44)
	.092 (2.34)

Table III: Dimensions

Shell Size	B Thread	P ±.010 (.25)	R Bsc	S ±.012 (.30)	Ø J ±.005 (.13)	Ø K Bsc	Ø L ±.005 (.13)	Rad H ±.020 (.51)	N ±.020 (.51)
9	.6250-1P-.3L-TS-2A	.225 (5.7)	.719 (18.3)	.937 (23.8)	1.016 (25.8)	.752 (19.1)	.532 (13.5)	.225 (5.7)	.275 (7.0)
11	.7500-1P-.3L-TS-2A	.250 (6.4)	.812 (20.6)	1.181 (30.0)	1.062 (27.0)	.850 (21.6)	.595 (15.1)	.250 (6.4)	.290 (7.4)
13	.8750-1P-.3L-TS-2A	.250 (6.4)	.906 (23.0)	1.277 (32.4)	1.250 (31.8)	.994 (25.2)	.720 (18.3)	.375 (9.5)	.370 (9.4)
15	1.0000-1P-.3L-TS-2A	.325 (8.2)	.969 (24.6)	1.371 (34.8)	1.375 (34.9)	1.119 (28.4)	.843 (21.4)	.438 (11.1)	.440 (11.2)
17	1.1875-1P-.3L-TS-2A	.375 (9.5)	1.062 (27.0)	1.462 (37.1)	1.500 (38.1)	1.237 (31.4)	1.000 (25.4)	.562 (14.3)	.495 (12.6)
19	1.2500-1P-.3L-TS-2A	.500 (12.7)	1.156 (29.4)	1.588 (40.3)	1.625 (41.3)	1.379 (35.0)	1.125 (28.6)	.875 (22.2)	.540 (13.7)
21	1.3750-1P-.3L-TS-2A	.562 (14.3)	1.250 (31.8)	1.714 (43.5)	1.750 (44.5)	1.489 (37.8)	1.240 (31.5)	1.170 (29.7)	.625 (15.9)
23	1.5000-1P-.3L-TS-2A	.688 (17.5)	1.375 (34.9)	1.840 (46.7)	1.875 (47.6)	1.619 (41.1)	1.328 (33.7)	1.250 (31.8)	.660 (16.8)
25	1.6250-1P-.3L-TS-2A	.750 (19.1)	1.500 (38.1)	1.962 (49.8)	2.000 (50.8)	1.744 (44.3)	1.453 (36.9)	1.375 (34.9)	.740 (18.8)

Dimensions in inches (millimeters) and are subject to change without notice.

D38999 SERIES III TYPE DUAL FLANGE JAM NUT RECEPTACLE WITH PC TAILS

How To Order										
Sample Part Number	240-383	E	ME	15-35	P	P	P	A	N	N
Filter Connector	MIL-DTL-38999 Series III Type									
Shell Style	E = Dual Flange Jam Nut									
Connector Class	See Table I									
Insert Arrangement	IAW MIL-STD-1560. (See pages B-28 – B-29)									
Contact Gender	P = Pin S = Socket									
Termination	P = PC Tail									
Filter Type	P = Pi Circuit C = C Circuit (See Note 1)									
Capacitance	See Table II									
Flange Mounting Style	N = Not Applicable									
Alternate Key Position	A, B, C, D, E, N = Normal (See page B-29)									

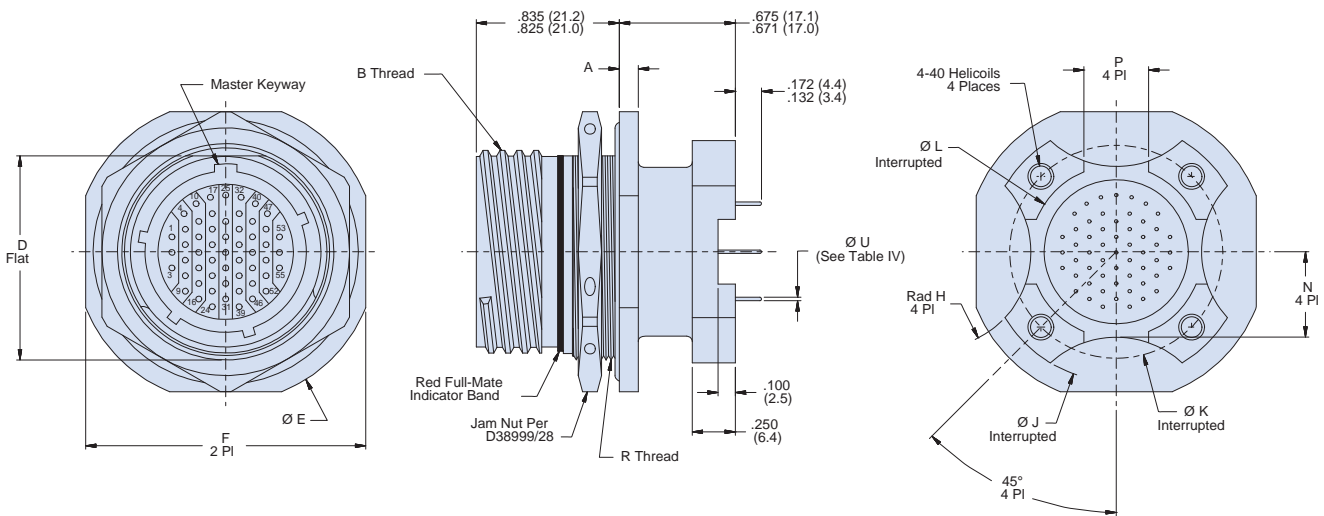
Notes

- Other filter styles (C-L, L-C, Unbalanced Pi, Multi-Stage, Multi-Value) are available, please consult the factory.

Dimensions in inches (millimeters) and are subject to change without notice.

240-383E
MIL-DTL-38999 Series III Type Filter Connector
Dual Flange Jam Nut Receptacle with PC Tails



MIL-DTL-38999
Type

B

Sym	Class	Material	Finish Description
ME	Environmental	Aluminum	Electroless Nickel
MT	Environmental	Aluminum	Ni-PTFE 1000 Hour Grey™ Nickel Fluorocarbon Polymer
NF	Environmental	Aluminum	Cadmium O.D. Over Electroless Nickel
ZL	Environmental	Stainless Steel	Electro-Deposited Nickel
XM	Environmental	Composite	Electroless Nickel
XMT	Environmental	Composite	Ni-PTFE 1000 Hour Grey™ Nickel Fluorocarbon Polymer
XW	Environmental	Composite	Cadmium O.D. Over Electroless Nickel
ZN	Environmental	Aluminum	Zinc-Nickel, Olive Drab
ZR	Environmental	Aluminum	Zinc Nickel, Black - RoHS
H2*	Hermetic	Stainless Steel	Electro-Deposited Nickel

*Some dimensions do not apply. See drawing 240-383EH2

Class	Pi - Circuit (pF)	C - Circuit (pF)
X*	160,000 - 240,000	80,000 - 120,000
Y*	80,000 - 120,000	40,000 - 60,000
Z*	60,000 - 90,000	30,000 - 45,000
A	38,000 - 56,000	19,000 - 28,000
B	32,000 - 45,000	16,000 - 22,500
C	18,000 - 33,000	9,000 - 16,500
D	8,000 - 12,000	4,000 - 6,000
E	3,300 - 5,000	1,650 - 2,500
F	800 - 1,300	400 - 650
G	400 - 600	200 - 300
J	70-120	35-60

* Filter Classes X, Y and Z are 250 VDC. All others are 500 VDC

Contact Size	Ø U
22D	.021 (0.53)
	.018 (0.46)
20	.031 (0.79)
	.029 (0.74)
16	.042 (1.07)
	.038 (0.97)
12	.096 (2.44)
	.092 (2.34)

Consult Factory for Additional Filter Types, TVS Diodes, and other Custom Configurations.

Shell Size	B Thread	D ±.005 (.13)	Ø E ±.012 (.30)	F ±.016 (.40)	P ±.010 (.25)	R Thread	Ø J ±.005 (.13)	Ø K Bsc	Ø L ±.005 (.13)	Rad H ±.020 (.51)	N ±.020 (.51)	A
9	.6250-.1P-.3L-TS-2A	.650 (16.5)	1.189 (30.2)	1.063 (27.0)	.225 (5.7)	M17 X 1.0-6g 0.100R	1.016 (25.8)	.752 (19.1)	.532 (13.5)	.225 (5.7)	.275 (7.0)	.122 (3.1) .083 (2.1)
11	.7500-.1P-.3L-TS-2A	.750 (19.1)	1.374 (34.9)	1.252 (31.8)	.250 (6.4)	M20 X 1.0-6g 0.100R	1.062 (27.0)	.850 (21.6)	.595 (15.1)	.250 (6.4)	.290 (7.4)	.122 (3.1) .083 (2.1)
13	.8750-.1P-.3L-TS-2A	.937 (23.8)	1.500 (38.1)	1.374 (34.9)	.250 (6.4)	M25 X 1.0-6g 0.100R	1.250 (31.8)	.994 (25.2)	.720 (18.3)	.375 (9.5)	.370 (9.4)	.122 (3.1) .083 (2.1)
15	1.0000-.1P-.3L-TS-2A	1.061 (26.9)	1.626 (41.3)	1.500 (38.1)	.325 (8.2)	M28 X 1.0-6g 0.100R	1.375 (34.9)	1.119 (28.4)	.843 (21.4)	.438 (11.1)	.440 (11.2)	.122 (3.1) .083 (2.1)
17	1.1875-.1P-.3L-TS-2A	1.186 (30.1)	1.752 (44.5)	1.626 (41.3)	.375 (9.5)	M32 X 1.0-6g 0.100R	1.500 (38.1)	1.237 (31.4)	1.000 (25.4)	.562 (14.3)	.495 (12.6)	.122 (3.1) .083 (2.1)
19	1.2500-.1P-.3L-TS-2A	1.311 (33.3)	1.937 (49.2)	1.811 (46.0)	.500 (12.7)	M35 X 1.0-6g 0.100R	1.625 (41.3)	1.379 (35.0)	1.125 (28.6)	.875 (22.2)	.540 (13.7)	.154 (3.9) .114 (2.9)
21	1.3750-.1P-.3L-TS-2A	1.436 (36.5)	2.063 (52.4)	1.937 (49.2)	.562 (14.3)	M38 X 1.0-6g 0.100R	1.750 (44.5)	1.489 (37.8)	1.240 (31.5)	1.170 (29.7)	.625 (15.9)	.154 (3.9) .114 (2.9)
23	1.5000-.1P-.3L-TS-2A	1.561 (39.7)	2.189 (55.6)	2.063 (52.4)	.688 (17.5)	M41 X 1.0-6g 0.100R	1.875 (47.6)	1.619 (41.1)	1.328 (33.7)	1.250 (31.8)	.660 (16.8)	.154 (3.9) .114 (2.9)
25	1.6250-.1P-.3L-TS-2A	1.686 (42.8)	2.311 (58.7)	2.189 (55.6)	.750 (19.1)	M44 X 1.0-6g 0.100R	2.000 (50.8)	1.744 (44.3)	1.453 (36.9)	1.375 (34.9)	.740 (18.8)	.154 (3.9) .114 (2.9)

Dimensions in inches (millimeters) and are subject to change without notice.

D38999 SERIES III TYPE FILTER CONNECTOR ADAPTER

How To Order									
Sample Part Number	240-383	B	ME	15-35	PS	P	A	N	N
Filter Connector	MIL-DTL-38999 Series III Type								
Shell Style	B = Connector Adapter								
Connector Class	See Table I								
Insert Arrangement	IAW MIL-STD-1560. (See pages B-28 – B-29)								
Contact Gender	PS = Pins, Plug Side SP = Sockets, Plug Side (See Note 2)								
Filter Type	P = Pi Circuit C = C Circuit (See Note 1)								
Capacitance	See Table II								
Flange Mounting Style	N = Not Applicable								
Alternate Key Position	A, B, C, D, E, N = Normal, U = Universal (See page B-29) (See Note 3)								

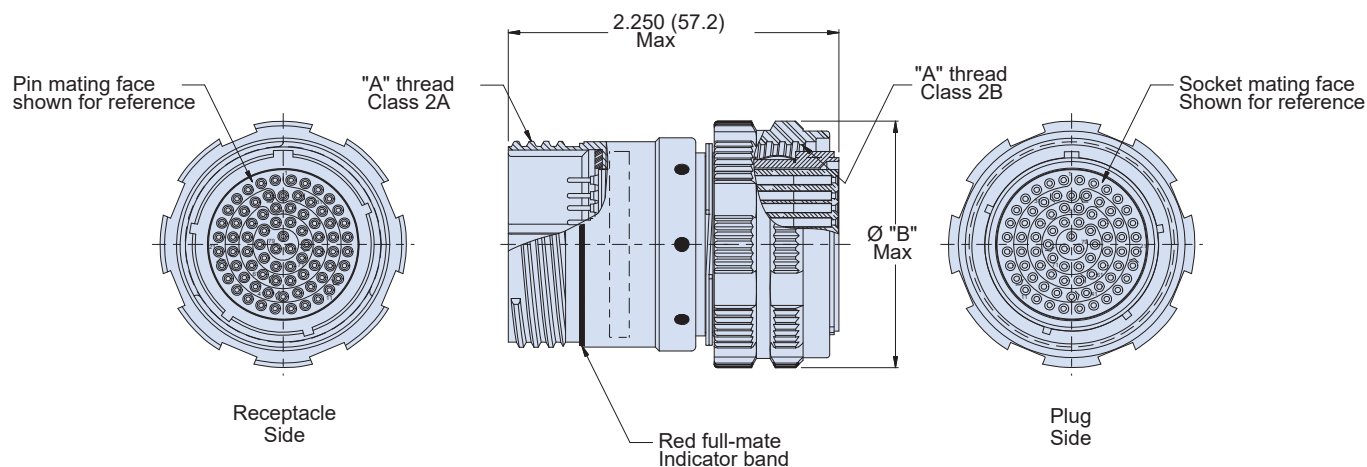

Notes

1. Other filter styles (C-L, L-C, Unbalanced Pi, Multi-Stage, Multi-Value) are available, please consult the factory.
2. Please consult the factory for Pin/Pin and/or Socket/Socket contact arrangements
3. Do not mate Universal key position with another Universal

Dimensions in inches (millimeters) and are subject to change without notice.

240-383B
MIL-DTL-38999 Series III Type Filter Connector
Connector Adapter



MIL-DTL-38999
Type

B

Table I: Connector Class

Sym	Class	Material	Finish Description
ME	Environmental	Aluminum	Electroless Nickel
MT	Environmental	Aluminum	Ni-PTFE 1000 Hour Grey™ Nickel Fluorocarbon Polymer
NF	Environmental	Aluminum	Cadmium O.D. Over Electroless Nickel
ZL	Environmental	Stainless Steel	Electro-Deposited Nickel
ZN	Environmental	Aluminum	Zinc-Nickel, Olive Drab
ZR	Environmental	Aluminum	Zinc Nickel, Black - RoHS
XM	Environmental	Composite	Electroless Nickel
XMT	Environmental	Composite	Nickel Fluorocarbon Polymer (Ni-PTFE)
XW	Environmental	Composite	Cadmium O.D. Over Electroless Nickel

Table II: Capacitor Array Code Capacitance Range

Class	Pi - Circuit (pF)	C - Circuit (pF)
X*	160,000 - 240,000	80,000 - 120,000
Y*	80,000 - 120,000	40,000 - 60,000
Z*	60,000 - 90,000	30,000 - 45,000
A	38,000 - 56,000	19,000 - 28,000
B	32,000 - 45,000	16,000 - 22,500
C	18,000 - 33,000	9,000 - 16,500
D	8,000 - 12,000	4,000 - 6,000
E	3,300 - 5,000	1,650 - 2,500
F	800 - 1,300	400 - 650
G	400 - 600	200 - 300
J	70-120	35-60

* Filter Classes X, Y and Z are 250 VDC.
All others are 500 VDC

Table III: Dimensions

Shell Size	A Thread Class 2	Ø B Max
9	.6250- .1P- .3L-TS	.858 (21.8)
11	.7500- .1P- .3L-TS	.984 (25.0)
13	.8750- .1P- .3L-TS	1.157 (29.4)
15	1.000- .1P- .3L-TS	1.280 (32.5)
17	1.1875- .1P- .3L-TS	1.406 (35.7)
19	1.2500- .1P- .3L-TS	1.516 (38.5)
21	1.3750- .1P- .3L-TS	1.642 (41.7)
23	1.5000- .1P- .3L-TS	1.768 (44.9)
25	1.6250- .1P- .3L-TS	1.890 (48.0)

Consult Factory for Additional Filter Types, TVS Diodes, and other Custom Configurations.

Dimensions in inches (millimeters) and are subject to change without notice.

	240-384J	Jam Nut Receptacles	Page B-52
	240-384S	<i>New!</i> Jam Nut Receptacles with Crimp Removable Contacts	Page B-54
	240-384W	Wall Mount Receptacles	Page B-56
	240-384R	<i>New!</i> Wall Mount Receptacles with Crimp Removable Contacts	Page B-58

Notes

1. Materials/Finishes: Shells, Jam Nut - See Table I
Insulators - High grade rigid dielectric/N.A.
Seals - Fluorosilicone
Contacts: Copper alloy 50 μ " Gold over 50 μ " Nickel
2. Assembly to be identified with Glenair's name, part number, and date code - space permitting.
3. Insert Arrangement in accordance with MIL-STD-1560. (Arrangement shown for reference only)
4. EMI Circular Filter Receptacle connectors designed to meet requirements of MIL-STD-2120 and MIL-DTL-38999, Series IV.
5. All contacts to have identical filter value. Other filter arrangements available, contact factory.
6. Electrical Ratings: DWV- 500 VDC; Standard Operating Voltage 200 VDC (Filter class X, Y and Z are 250 VDC)
7. Insulation Resistance: 5000 MegOhms Min. at 200 VDC.
8. Operating Temperature: -55°C to +125°C (Env Class Connectors)
9. Other filter styles (C-L, L-C, Unbalanced Pi, Multi-Stage, Multi-Value) are available, please consult the factory.

Dimensions in inches (millimeters) and are subject to change without notice.

MIL-DTL-38999 Series IV Type Filter Connector with Breach-Lock Coupling



MIL-DTL-38999
Type

B

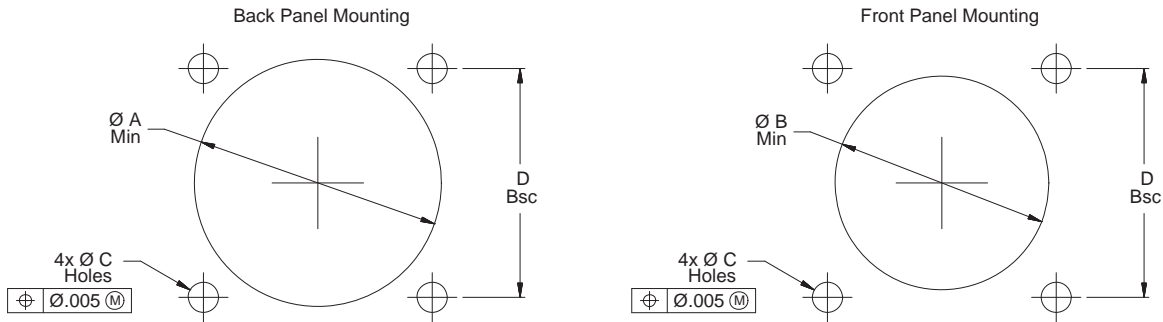

MIL-DTL-38999 Series IV Square Flange Panel Cut-Outs				
Shell Size	Ø A Min Back Panel	Ø B Min Front Panel	Ø C Holes	D Bsc
11	.796 (20.2)	.625 (15.9)	.133 (3.4) .123 (3.1)	.812 (20.6)
13	.922 (23.4)	.750 (19.1)		.906 (23.0)
15	1.047 (26.6)	.906 (23.0)		.969 (24.6)
17	1.219 (31.0)	1.016 (25.8)		1.062 (27.0)
19	1.297 (32.9)	1.141 (29.0)		1.156 (29.4)
21	1.422 (36.1)	1.266 (32.2)		1.250 (31.8)
23	1.547 (39.3)	1.375 (34.9)	.159 (4.0) .149 (3.8)	1.375 (34.9)
25	1.672 (42.5)	1.484 (37.7)	.155 (3.9) .145 (3.7)	1.500 (38.1)

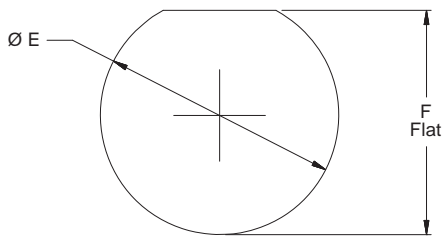

MIL-DTL-38999 Series IV Jam Nut Panel Cut-Out		
Shell Size	Ø E	F Flat
11	1.010 (25.7)	.945 (24.0)
	1.020 (25.9)	.955 (24.3)
13	1.135 (28.8)	1.075 (27.3)
	1.145 (29.1)	1.085 (27.6)
15	1.260 (32.0)	1.200 (30.5)
	1.270 (32.3)	1.210 (30.7)
17	1.385 (35.2)	1.325 (33.7)
	1.395 (35.4)	1.335 (33.9)
19	1.510 (38.4)	1.450 (36.8)
	1.520 (38.6)	1.460 (37.1)
21	1.635 (41.5)	1.575 (40.0)
	1.645 (41.8)	1.585 (40.3)
23	1.760 (44.7)	1.700 (43.2)
	1.770 (45.0)	1.710 (43.4)
25	1.885 (47.9)	1.825 (46.4)
	1.895 (48.1)	1.835 (46.6)

Dimensions in inches (millimeters) and are subject to change without notice.

MIL-STD-1560 Insert Arrangements (Pin Front View) and Shell Polarization for MIL-DTL-38999 Series IV Type Filter Connectors

B

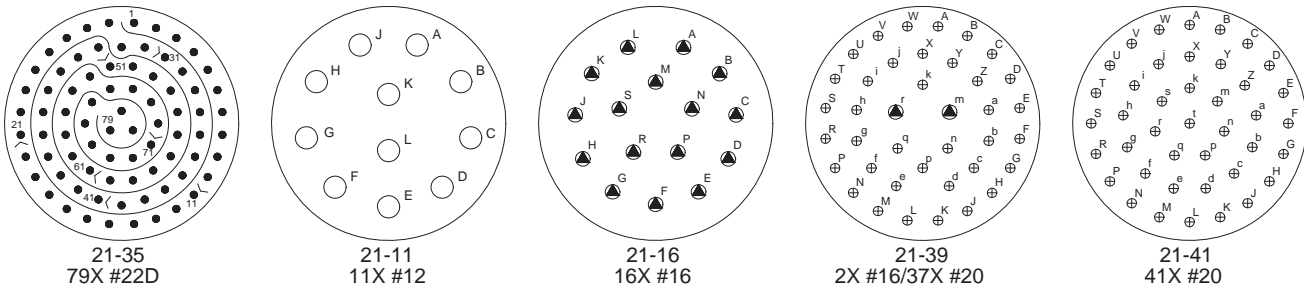
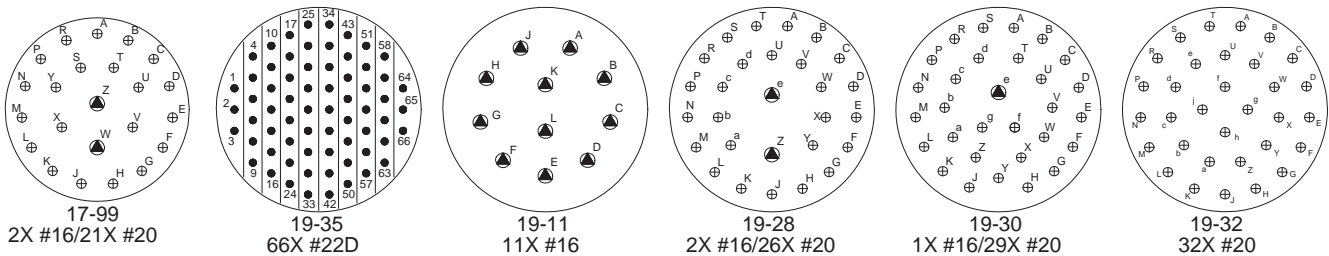
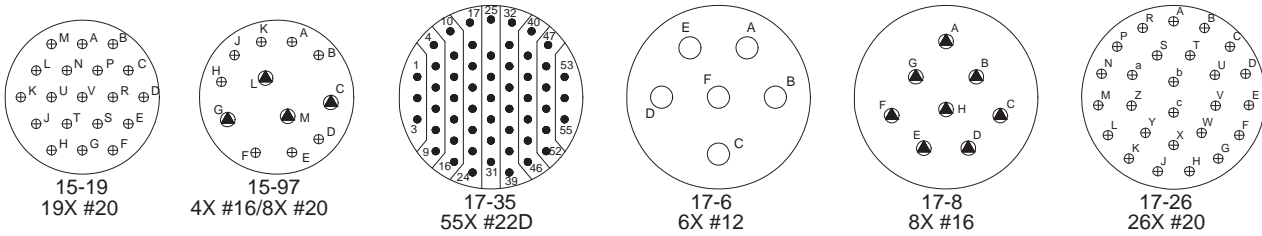
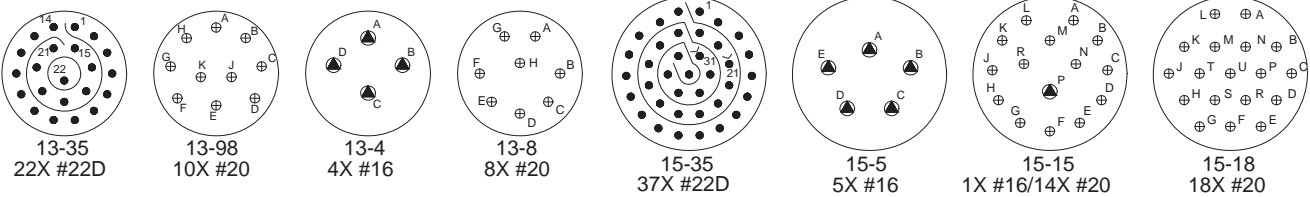
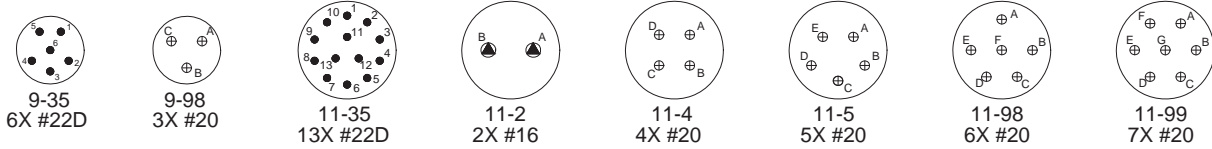

SYM	SIZE
●	#22D
⊕	#20
▲	#16
○	#12

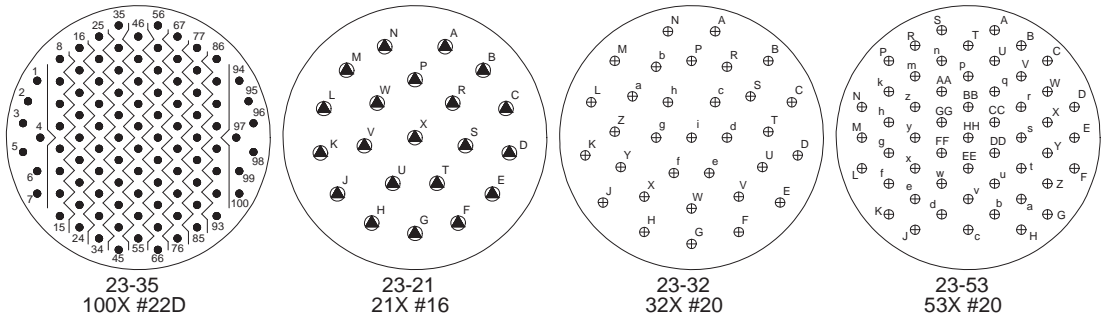

Dimensions in inches (millimeters) and are subject to change without notice.

MIL-STD-1560 Insert Arrangements (Pin Front View) and Shell Polarization for MIL-DTL-38999 Series IV Type Filter Connectors



MIL-DTL-38999
Type

B

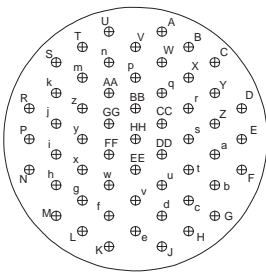

23-55
55X #20

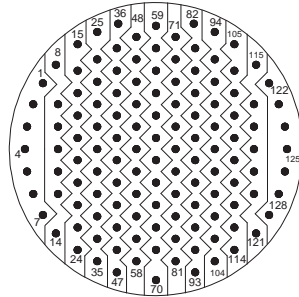

25-35
128X #22D

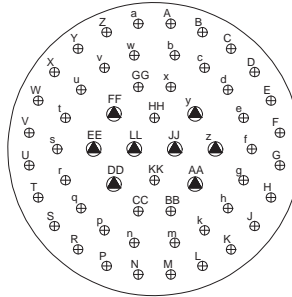

25-4
8X #16/48X #20

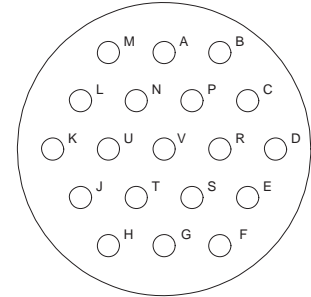

25-19
19X #12

SYM	SIZE
●	#22D
⊕	#20
▲	#16
○	#12

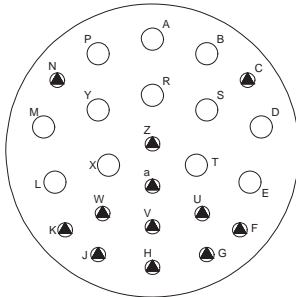

25-24
12X #12/12X #16

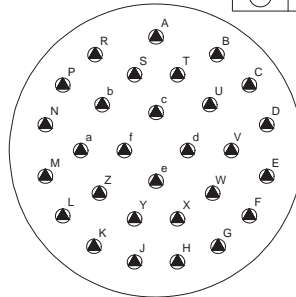

25-29
29X #16

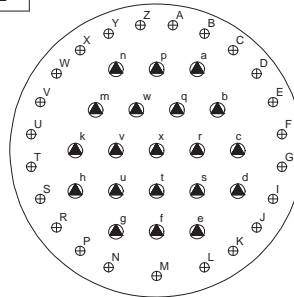

25-43
20X #16/23X #20

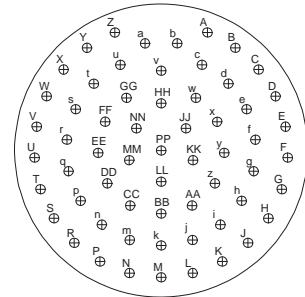

25-61
61X #20

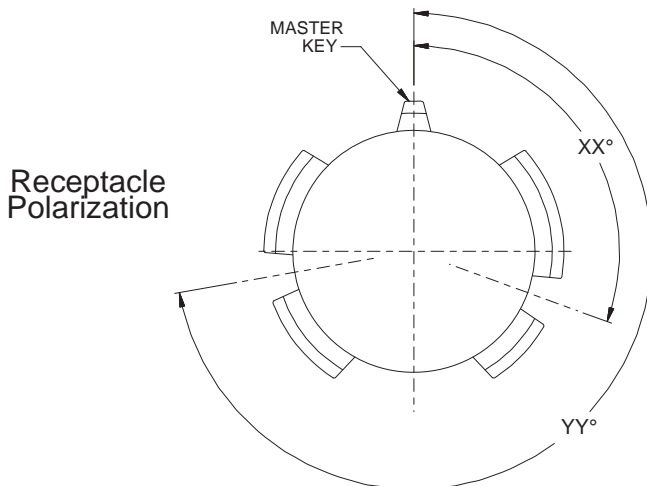

MIL-DTL-38999 Series IV Keying Positions		
Keying Position	XX° Bsc	YY° Bsc
N	110°	250°
A	100°	260°
B	90°	270°
C	80°	280°
D	70°	290°
K	120°	255°
L	120°	265°
M	120°	275°
R	120°	285°
U	0°	0°

Dimensions in inches (millimeters) and are subject to change without notice.

© 2013 Glenair, Inc.

U.S. CAGE Code 06324

Printed in U.S.A.

D38999 SERIES IV TYPE JAM NUT RECEPTACLE

How To Order										
Sample Part Number	240-384	J	NF	15-35	P	P	P	A	N	N
Filter Connector	MIL-DTL-38999 Series IV Type									
Shell Style	J = Jam Nut									
Connector Class	See Table I									
Insert Arrangement	IAW MIL-STD-1560. (See pages B-50 – B-51)									
Contact Gender	P = Pin S = Socket									
Termination	S = Solder Cup P = PC Tail									
Filter Type	P = Pi Circuit C = C Circuit (See Note 1)									
Capacitance	See Table II									
Flange Mounting Style	N = Not Applicable									
Alternate Key Position	A, B, C, D, K, L, M, R, U, N = Normal (See page B-51)									

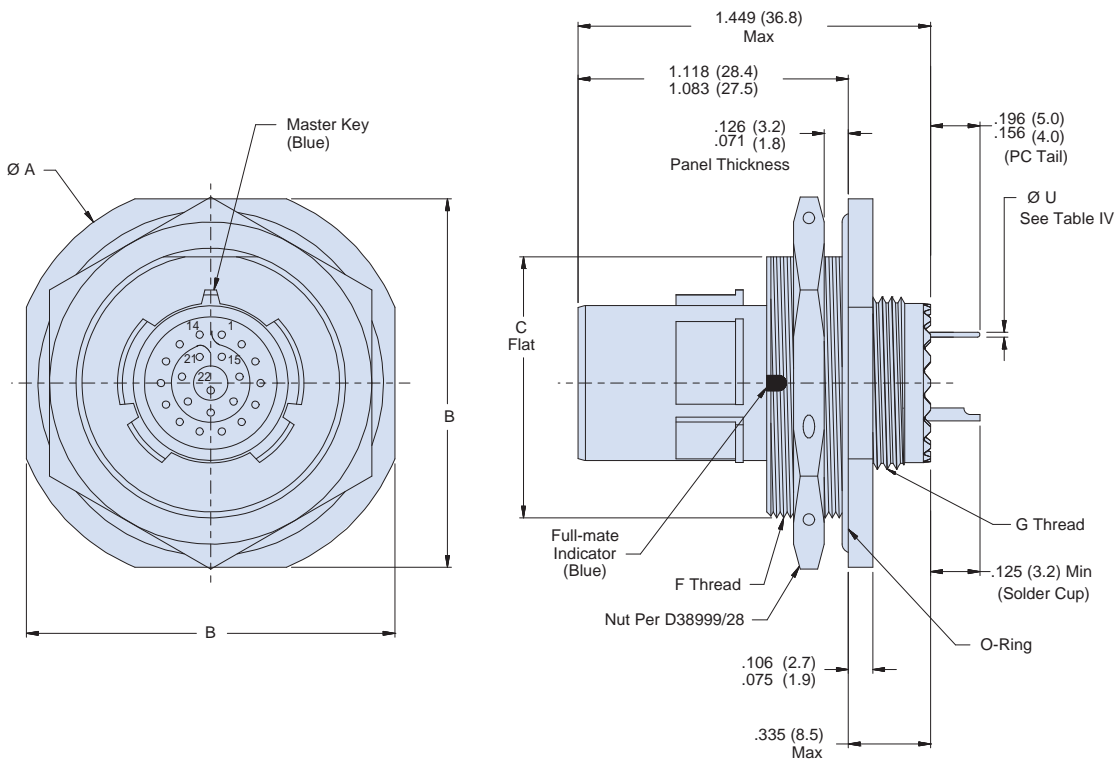

Notes

- Other filter styles (C-L, L-C, Unbalanced Pi, Multi-Stage, Multi-Value) are available, please consult the factory.

Dimensions in inches (millimeters) and are subject to change without notice.

240-384J
MIL-DTL-38999 Series IV Type Filter Connector
Jam Nut Receptacle



MIL-DTL-38999
Type

B

Table I: Connector Class			
Sym	Class	Material	Finish Description
ME	Environmental	Aluminum	Electroless Nickel
MT	Environmental	Aluminum	Ni-PTFE 1000 Hour Grey™ Nickel Fluorocarbon Polymer
NF	Environmental	Aluminum	Cadmium O.D. Over Electroless Nickel
ZL	Environmental	Stainless Steel	Electro-Deposited Nickel
ZN	Environmental	Aluminum	Zinc-Nickel, Olive Drab
ZR	Environmental	Aluminum	Zinc Nickel, Black - RoHS
H2*	Hermetic	Stainless Steel	Electro-Deposited Nickel

*Some dimensions do not apply. See drawing 240-384JH2

Table II: Capacitor Array Code Capacitance Range		
Class	Pi - Circuit (pF)	C - Circuit (pF)
X*	160,000 - 240,000	80,000 - 120,000
Y*	80,000 - 120,000	40,000 - 60,000
Z*	60,000 - 90,000	30,000 - 45,000
A	38,000 - 56,000	19,000 - 28,000
B	32,000 - 45,000	16,000 - 22,500
C	18,000 - 33,000	9,000 - 16,500
D	8,000 - 12,000	4,000 - 6,000
E	3,300 - 5,000	1,650 - 2,500
F	800 - 1,300	400 - 650
G	400 - 600	200 - 300
J	70-120	35-60

* Filter Classes X, Y and Z are 250 VDC.
 All others are 500 VDC

Table IV: PC Tail Dia	
Contact Size	Ø U
22D	.021 (0.53)
	.018 (0.46)
20	.031 (0.79)
	.029 (0.74)
16	.042 (1.07)
	.038 (0.97)
12	.096 (2.44)
	.092 (2.34)

Table III: Dimensions					
Shell Size	Ø A	B	C Flat	F Thread	G Thread
11	1.520 (38.6)	1.394 (35.4)	.942 (23.9)	M25 X 1.0-6g 0.100R	M15 X 1.0-6g 0.100R
	1.480 (37.6)	1.354 (34.4)	.935 (23.7)		
13	1.642 (41.7)	1.520 (38.6)	1.066 (27.1)	M28 X 1.0-6g 0.100R	M18 X 1.0-6g 0.100R
	1.602 (40.7)	1.480 (37.6)	1.059 (26.9)		
15	1.768 (44.9)	1.642 (41.7)	1.191 (30.3)	M31 X 1.0-6g 0.100R	M22 X 1.0-6g 0.100R
	1.728 (43.9)	1.602 (40.7)	1.184 (30.1)		
17	1.957 (49.7)	1.799 (45.7)	1.321 (33.6)	M34 X 1.0-6g 0.100R	M25 X 1.0-6g 0.100R
	1.917 (48.7)	1.760 (44.7)	1.314 (33.4)		
19	2.035 (51.7)	1.909 (48.5)	1.441 (36.6)	M38 X 1.0-6g 0.100R	M28 X 1.0-6g 0.100R
	1.996 (50.7)	1.870 (47.5)	1.434 (36.4)		
21	2.157 (54.8)	2.035 (51.7)	1.566 (39.8)	M41 X 1.0-6g 0.100R	M31 X 1.0-6g 0.100R
	2.118 (53.8)	1.996 (50.7)	1.559 (39.6)		
23	2.283 (58.0)	2.157 (54.8)	1.691 (43.0)	M44 X 1.0-6g 0.100R	M34 X 1.0-6g 0.100R
	2.244 (57.0)	2.118 (53.8)	1.684 (42.8)		
25	2.409 (61.2)	2.283 (58.0)	1.816 (46.1)	M47 X 1.0-6g 0.100R	M37 X 1.0-6g 0.100R
	2.370 (60.2)	2.244 (57.0)	1.809 (45.9)		

Dimensions in inches (millimeters) and are subject to change without notice.

D38999 SERIES IV TYPE JAM NUT RECEPTACLE WITH CRIMP REMOVABLE CONTACTS

How To Order										
Sample Part Number	240-384	S	NF	15-35	P	C	P	A	N	N
Filter Connector	MIL-DTL-38999 Series IV Type									
Shell Style	S = Jam Nut with Crimp Removable Contacts									
Connector Class	See Table I									
Insert Arrangement	IAW MIL-STD-1560. (See pages B-50 – B-51)									
Contact Gender	P = Pin S = Socket									
Termination	C = Crimp									
Filter Type	P = Pi Circuit C = C Circuit (See Note 2)									
Capacitance	See Table II									
Flange Mounting Style	N = Not Applicable									
Alternate Key Position	A, B, C, D, K, L, M, R, U, N = Normal (See page B-51)									

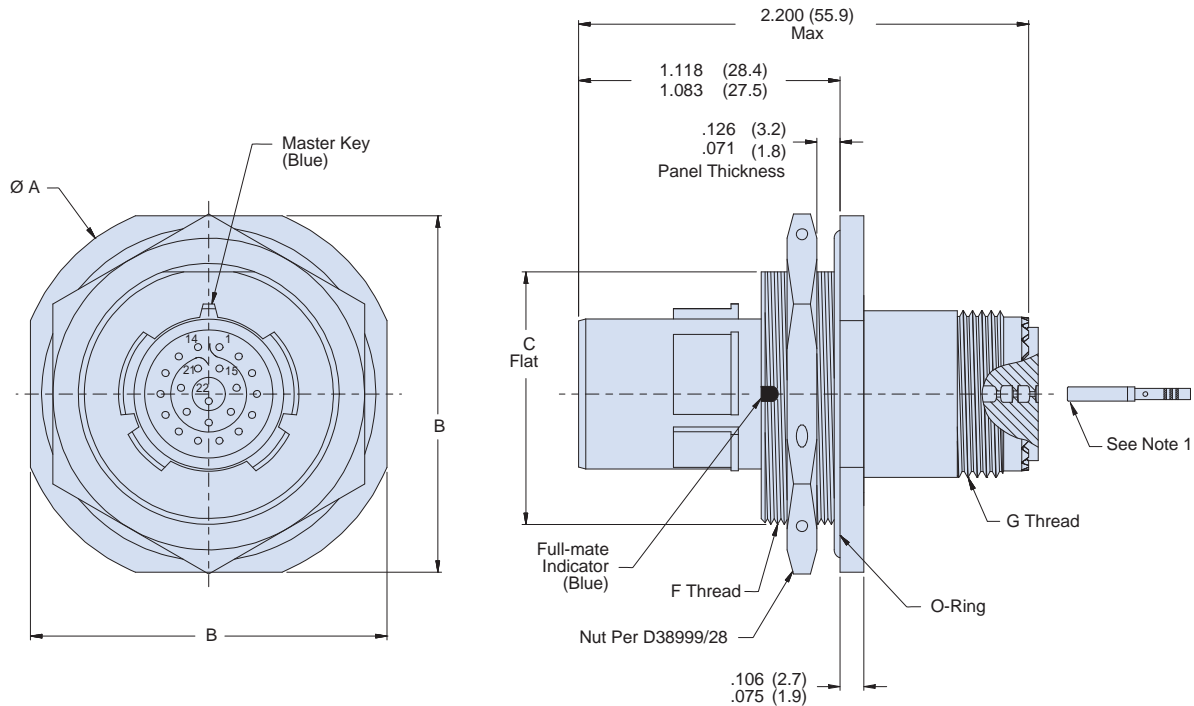
Notes

1. Crimp removable contacts to conform to MIL-C-39029/57-358, Size 16, MIL-C-39029/57-357 Size 20, and MIL-C-39029/57-354 Size 22D (Supplied loose).
2. Other filter styles (C-L, L-C, Unbalanced Pi, Multi-Stage, Multi-Value) are available, please consult the factory.

Dimensions in inches (millimeters) and are subject to change without notice.

240-384S
MIL-DTL-38999 Series IV Type Filter Connector
Jam Nut Receptacle with Crimp Removable Contacts



MIL-DTL-38999
Type

B

Sym	Class	Material	Finish Description
ME	Environmental	Aluminum	Electroless Nickel
MT	Environmental	Aluminum	Ni-PTFE 1000 Hour Grey™ Nickel Fluorocarbon Polymer
NF	Environmental	Aluminum	Cadmium O.D. Over Electroless Nickel
ZL	Environmental	Stainless Steel	Electro-Deposited Nickel
ZN	Environmental	Aluminum	Zinc-Nickel, Olive Drab
ZR	Environmental	Aluminum	Zinc Nickel, Black - RoHS
H2*	Hermetic	Stainless Steel	Electro-Deposited Nickel

*Some dimensions do not apply. See drawing 240-384SH2

Class	Pi - Circuit (pF)	C - Circuit (pF)
X*	160,000 - 240,000	80,000 - 120,000
Y*	80,000 - 120,000	40,000 - 60,000
Z*	60,000 - 90,000	30,000 - 45,000
A	38,000 - 56,000	19,000 - 28,000
B	32,000 - 45,000	16,000 - 22,500
C	18,000 - 33,000	9,000 - 16,500
D	8,000 - 12,000	4,000 - 6,000
E	3,300 - 5,000	1,650 - 2,500
F	800 - 1,300	400 - 650
G	400 - 600	200 - 300
J	70-120	35-60

* Filter Classes X, Y and Z are 250 VDC.
All others are 500 VDC

Shell Size	Ø A	B	C Flat	F Thread	G Thread
11	1.520 (38.6)	1.394 (35.4)	.942 (23.9)	M25 X 1.0-6g 0.100R	M15 X 1.0-6g 0.100R
	1.480 (37.6)	1.354 (34.4)	.935 (23.7)		
13	1.642 (41.7)	1.520 (38.6)	1.066 (27.1)	M28 X 1.0-6g 0.100R	M18 X 1.0-6g 0.100R
	1.602 (40.7)	1.480 (37.6)	1.059 (26.9)		
15	1.768 (44.9)	1.642 (41.7)	1.191 (30.3)	M31 X 1.0-6g 0.100R	M22 X 1.0-6g 0.100R
	1.728 (43.9)	1.602 (40.7)	1.184 (30.1)		
17	1.957 (49.7)	1.799 (45.7)	1.321 (33.6)	M34 X 1.0-6g 0.100R	M25 X 1.0-6g 0.100R
	1.917 (48.7)	1.760 (44.7)	1.314 (33.4)		
19	2.035 (51.7)	1.909 (48.5)	1.441 (36.6)	M38 X 1.0-6g 0.100R	M28 X 1.0-6g 0.100R
	1.996 (50.7)	1.870 (47.5)	1.434 (36.4)		
21	2.157 (54.8)	2.035 (51.7)	1.566 (39.8)	M41 X 1.0-6g 0.100R	M31 X 1.0-6g 0.100R
	2.118 (53.8)	1.996 (50.7)	1.559 (39.6)		
23	2.283 (58.0)	2.157 (54.8)	1.691 (43.0)	M44 X 1.0-6g 0.100R	M34 X 1.0-6g 0.100R
	2.244 (57.0)	2.118 (53.8)	1.684 (42.8)		
25	2.409 (61.2)	2.283 (58.0)	1.816 (46.1)	M47 X 1.0-6g 0.100R	M37 X 1.0-6g 0.100R
	2.370 (60.2)	2.244 (57.0)	1.809 (45.9)		

Dimensions in inches (millimeters) and are subject to change without notice.

D38999 SERIES IV TYPE WALL MOUNT RECEPTACLE

How To Order										
Sample Part Number	240-384	W	ME	15-35	P	S	P	C	H	N
Filter Connector	MIL-DTL-38999 Series IV Type									
Shell Style	W = Wall Mount									
Connector Class	See Table I									
Insert Arrangement	IAW MIL-STD-1560. (See pages B-50 – B-51)									
Contact Gender	P = Pin S = Socket									
Termination	P = PC Tail S = Solder Cup									
Filter Type	P = Pi Circuit C = C Circuit (See Note 1)									
Capacitance	See Table II									
Flange Mounting Style	H = Round Holes C = Clinch Nuts (4-40 UNC) M = Metric Clinch Nuts (M3)									
Alternate Key Position	A, B, C, D, K, L, M, R, U, N = Normal (See page B-51)									

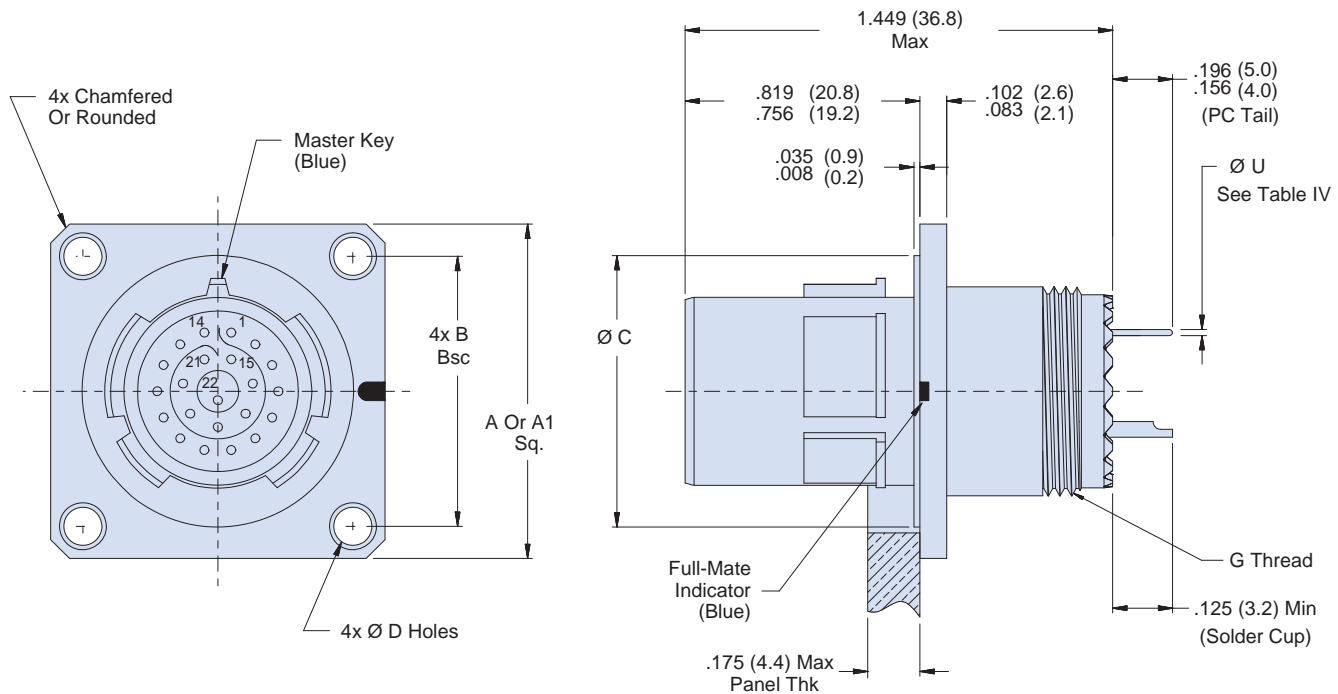

Notes

- Other filter styles (C-L, L-C, Unbalanced Pi, Multi-Stage, Multi-Value) are available, please consult the factory.

Dimensions in inches (millimeters) and are subject to change without notice.

240-384W
MIL-DTL-38999 Series IV Type Filter Connector
Wall Mount Receptacle



MIL-DTL-38999
Type

B

Table I: Connector Class

Sym	Class	Material	Finish Description
ME	Environmental	Aluminum	Electroless Nickel
MT	Environmental	Aluminum	Ni-PTFE 1000 Hour Grey™ Nickel Fluorocarbon Polymer
NF	Environmental	Aluminum	Cadmium O.D. Over Electroless Nickel
ZL	Environmental	Stainless Steel	Electro-Deposited Nickel
ZN	Environmental	Aluminum	Zinc-Nickel, Olive Drab
ZR	Environmental	Aluminum	Zinc Nickel, Black - RoHS
H2*	Hermetic	Stainless Steel	Electro-Deposited Nickel

*Some dimensions do not apply. See drawing 240-384WH2

Table II: Capacitor Array Code Capacitance Range

Class	Pi - Circuit (pF)	C - Circuit (pF)
X*	160,000 - 240,000	80,000 - 120,000
Y*	80,000 - 120,000	40,000 - 60,000
Z*	60,000 - 90,000	30,000 - 45,000
A	38,000 - 56,000	19,000 - 28,000
B	32,000 - 45,000	16,000 - 22,500
C	18,000 - 33,000	9,000 - 16,500
D	8,000 - 12,000	4,000 - 6,000
E	3,300 - 5,000	1,650 - 2,500
F	800 - 1,300	400 - 650
G	400 - 600	200 - 300
J	70-120	35-60

* Filter Classes X, Y and Z are 250 VDC.
All others are 500 VDC

Table IV: PC Tail Dia

Contact Size	Ø U
22D	.021 (0.53)
	.018 (0.46)
20	.031 (0.79)
	.029 (0.74)
16	.042 (1.07)
	.038 (0.97)
12	.096 (2.44)
	.092 (2.34)

Table III: Dimensions

Shell Size	Thru Hole Flange		Clinch Nut Flange	B Bsc	Ø C	G Thread
	A Sq.	Ø D Holes	A1 Sq. ±.020 (.51)			
11	1.051 (26.7) 1.008 (25.6)	.138 (3.5) .122 (3.1)	1.112 (28.2)	.812 (20.6)	.793 (20.1) .778 (19.8)	M15 X 1.0-6g 0.100R
13	1.145 (29.1) 1.102 (28.0)	.138 (3.5) .122 (3.1)	1.206 (30.6)	.906 (23.0)	.919 (23.3) .904 (23.0)	M18 X 1.0-6g 0.100R
15	1.240 (31.5) 1.197 (30.4)	.138 (3.5) .122 (3.1)	1.269 (32.2)	.969 (24.6)	1.044 (26.5) 1.029 (26.1)	M22 X 1.0-6g 0.100R
17	1.334 (33.9) 1.291 (32.8)	.138 (3.5) .122 (3.1)	1.362 (34.6)	1.062 (27.0)	1.170 (29.7) 1.155 (29.3)	M25 X 1.0-6g 0.100R
19	1.460 (37.1) 1.417 (36.0)	.138 (3.5) .122 (3.1)	1.456 (37.0)	1.156 (29.4)	1.294 (32.9) 1.279 (32.5)	M28 X 1.0-6g 0.100R
21	1.583 (40.2) 1.539 (39.1)	.138 (3.5) .122 (3.1)	1.562 (39.7)	1.250 (31.8)	1.419 (36.0) 1.404 (35.7)	M31 X 1.0-6g 0.100R
23	1.709 (43.4) 1.665 (42.3)	.157 (4.0) .142 (3.6)	1.719 (43.7)	1.375 (34.9)	1.544 (39.2) 1.529 (38.8)	M34 X 1.0-6g 0.100R
25	1.835 (46.6) 1.791 (45.5)	.157 (4.0) .142 (3.6)	1.844 (46.8)	1.500 (38.1)	1.670 (42.4) 1.654 (42.0)	M37 X 1.0-6g 0.100R

Dimensions in inches (millimeters) and are subject to change without notice.

D38999 SERIES IV TYPE WALL MOUNT RECEPTACLE WITH CRIMP REMOVABLE CONTACTS

How To Order	
Sample Part Number	240-384 R ME 15-35 P S P C H N
Filter Connector	MIL-DTL-38999 Series IV Type
Shell Style	R = Wall Mount with Crimp Contacts
Connector Class	See Table I
Insert Arrangement	IAW MIL-STD-1560. (See pages B-50 – B-51)
Contact Gender	P = Pin S = Socket
Termination	C = Crimp
Filter Type	P = Pi Circuit C = C Circuit (See Note 2)
Capacitance	See Table II
Flange Mounting Style	H = Round Holes C = Clinch Nuts (4-40 UNC) M = Metric Clinch Nuts (M3)
Alternate Key Position	A, B, C, D, K, L, M, R, U, N = Normal (See page B-51)

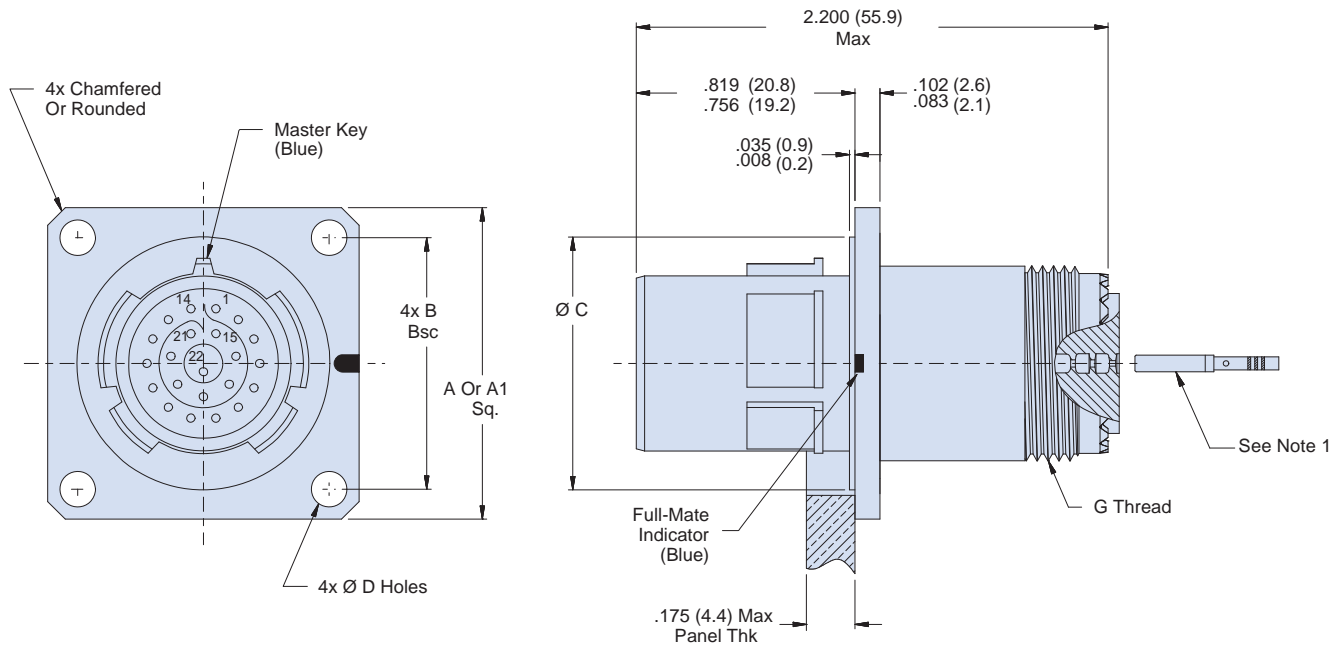

Notes

1. Crimp removable contacts to conform to MIL-C-39029/57-358, Size 16, MIL-C-39029/57-357 Size 20, and MIL-C-39029/57-354 Size 22D (Supplied loose).
2. Other filter styles (C-L, L-C, Unbalanced Pi, Multi-Stage, Multi-Value) are available, please consult the factory.

Dimensions in inches (millimeters) and are subject to change without notice.

240-384R
MIL-DTL-38999 Series IV Type Filter Connector
Wall Mount Receptacle with Crimp Removable Contacts



MIL-DTL-38999
Type

B

Table I: Connector Class			
Sym	Class	Material	Finish Description
ME	Environmental	Aluminum	Electroless Nickel
MT	Environmental	Aluminum	Ni-PTFE 1000 Hour Grey™ Nickel Fluorocarbon Polymer
NF	Environmental	Aluminum	Cadmium O.D. Over Electroless Nickel
ZL	Environmental	Stainless Steel	Electro-Deposited Nickel
ZN	Environmental	Aluminum	Zinc-Nickel, Olive Drab
ZR	Environmental	Aluminum	Zinc Nickel, Black - RoHS
H2*	Hermetic	Stainless Steel	Electro-Deposited Nickel

*Some dimensions do not apply. See drawing 240-384RH2

Table II: Capacitor Array Code Capacitance Range		
Class	Pi - Circuit (pF)	C - Circuit (pF)
X*	160,000 - 240,000	80,000 - 120,000
Y*	80,000 - 120,000	40,000 - 60,000
Z*	60,000 - 90,000	30,000 - 45,000
A	38,000 - 56,000	19,000 - 28,000
B	32,000 - 45,000	16,000 - 22,500
C	18,000 - 33,000	9,000 - 16,500
D	8,000 - 12,000	4,000 - 6,000
E	3,300 - 5,000	1,650 - 2,500
F	800 - 1,300	400 - 650
G	400 - 600	200 - 300
J	70-120	35-60

* Filter Classes X, Y and Z are 250 VDC.
All others are 500 VDC

Table III: Dimensions						
Shell Size	Thru Hole Flange		Clinch Nut Flange	B Bsc	Ø C	G Thread
	A Sq.	Ø D Holes	A1 Sq. ±.020 (.51)			
11	1.051 (26.7) 1.008 (25.6)	.138 (3.5) .122 (3.1)	1.112 (28.2)	.812 (20.6)	.793 (20.1) .778 (19.8)	M15 X 1.0-6g 0.100R
13	1.145 (29.1) 1.102 (28.0)	.138 (3.5) .122 (3.1)	1.206 (30.6)	.906 (23.0)	.919 (23.3) .904 (23.0)	M18 X 1.0-6g 0.100R
15	1.240 (31.5) 1.197 (30.4)	.138 (3.5) .122 (3.1)	1.269 (32.2)	.969 (24.6)	1.044 (26.5) 1.029 (26.1)	M22 X 1.0-6g 0.100R
17	1.334 (33.9) 1.291 (32.8)	.138 (3.5) .122 (3.1)	1.362 (34.6)	1.062 (27.0)	1.170 (29.7) 1.155 (29.3)	M25 X 1.0-6g 0.100R
19	1.460 (37.1) 1.417 (36.0)	.138 (3.5) .122 (3.1)	1.456 (37.0)	1.156 (29.4)	1.294 (32.9) 1.279 (32.5)	M28 X 1.0-6g 0.100R
21	1.583 (40.2) 1.539 (39.1)	.138 (3.5) .122 (3.1)	1.562 (39.7)	1.250 (31.8)	1.419 (36.0) 1.404 (35.7)	M31 X 1.0-6g 0.100R
23	1.709 (43.4) 1.665 (42.3)	.157 (4.0) .142 (3.6)	1.719 (43.7)	1.375 (34.9)	1.544 (39.2) 1.529 (38.8)	M34 X 1.0-6g 0.100R
25	1.835 (46.6) 1.791 (45.5)	.157 (4.0) .142 (3.6)	1.844 (46.8)	1.500 (38.1)	1.670 (42.4) 1.654 (42.0)	M37 X 1.0-6g 0.100R

Dimensions in inches (millimeters) and are subject to change without notice.

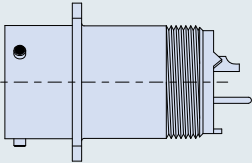
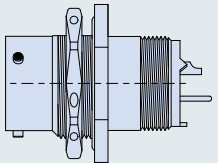
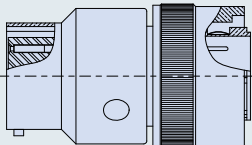
	240-264W	Wall Mount Receptacles Narrow Flange	Page B-64
	240-264J	Jam Nut Receptacles	Page B-66
	240-264A	Connector Adapters	Page B-68

Notes

1. Materials/Finishes: Shells, Barrel, Coupling Nut, Jam Nut - See Table I
Insulators - high grade rigid dielectric/N.A.
Seals - Silicone
Contacts: Copper alloy 50 μ " Gold over 50 μ " Nickel
2. Assembly to be identified with Glenair's name, part number, and date code - space permitting.
3. Insert Arrangement in accordance with MIL-STD-1669. (Arrangement shown for reference only)
4. EMI Circular Filter Receptacle connectors designed to meet requirements of MIL-STD-2120 and MIL-DTL-26482, Series II.
5. All contacts to have identical filter value. Other filter arrangements available, contact factory.
6. Electrical Ratings: DWV- 500 VDC; Standard Operating Voltage 200 VDC (Filter class X, Y and Z are 250 VDC)
7. Insulation Resistance: 5,000 MEGOHMS min @ 200VDC for Class A, B, C, D, E, F, G & J. 1,000 MEGOHMS @ 83VDC for classes, X, Y, & Z
8. Operating Temperature -55°C to +125°C (Env Class Connectors)
9. Other filter styles (C-L, L-C, Unbalanced Pi, Multi-Stage, Multi-Value) are available, please consult the factory.

Dimensions in inches (millimeters) and are subject to change without notice.

MIL-DTL-26482 Series II Type Filter Connector with Bayonet Coupling Insert Arrangements



MIL-DTL-26482
Type

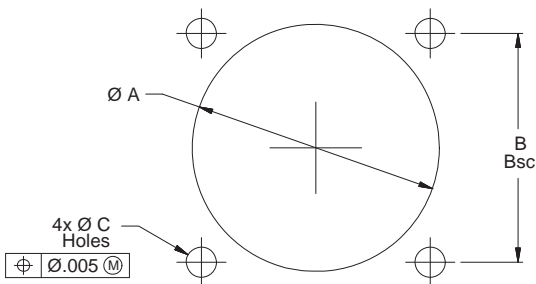

Narrow Flange
Mount Per MS3470

MIL-DTL-26482 Series II Narrow Flange Panel Cutouts			
Shell Size	Ø A	B Bsc	Ø C Holes
8	.573 (14.6)	.594 (15.1)	.130 (3.3) .110 (2.8)
	.563 (14.3)		
10	.690 (17.5)	.719 (18.3)	
	.680 (17.3)		
12	.869 (22.1)	.812 (20.6)	
	.859 (21.8)		
14	.994 (25.2)	.906 (23.0)	
	.984 (25.0)		
16	1.118 (28.4)	.969 (24.6)	
	1.108 (28.1)		
18	1.243 (31.6)	1.062 (27.0)	
	1.233 (31.3)		
20	1.368 (34.7)	1.156 (29.4)	
	1.358 (34.5)		
22	1.493 (37.9)	1.250 (31.8)	
	1.483 (37.7)		
24	1.620 (41.1)	1.375 (34.9)	.157 (4.0)
	1.610 (40.9)		.137 (3.5)

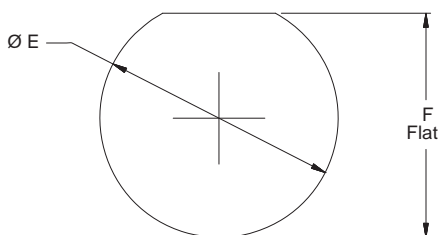

NOTE: Glenair MIL-DTL-26482 type filter connectors mate with both Series I and II 26482 products

MIL-DTL-26482 Series II Jam Nut Panel Cut-Out		
Shell Size	Ø E	F Flat
8	.577 (14.7)	.541 (13.7)
	.567 (14.4)	.531 (13.5)
10	.702 (17.8)	.666 (16.9)
	.692 (17.6)	.656 (16.7)
12	.900 (22.9)	.829 (21.1)
	.890 (22.6)	.819 (20.8)
14	1.015 (25.8)	.953 (24.2)
	1.005 (25.5)	.943 (24.0)
16	1.140 (29.0)	1.077 (27.4)
	1.130 (28.7)	1.067 (27.1)
18	1.265 (32.1)	1.202 (30.5)
	1.255 (31.9)	1.192 (30.3)
20	1.390 (35.3)	1.327 (33.7)
	1.380 (35.1)	1.317 (33.5)
22	1.515 (38.5)	1.452 (36.9)
	1.505 (38.2)	1.442 (36.6)
24	1.640 (41.7)	1.577 (40.1)
	1.630 (41.4)	1.567 (39.8)

Dimensions in inches (millimeters) and are subject to change without notice.





MIL-STD-1669 Insert Arrangements (Pin Front View) and Insert Positions for MIL-DTL-26482 Series II Type Filter Connectors

B



8-2
2X #20



8-3
3X #20



8-4
4X #20



8-33
3X #20



8-98
3X #20

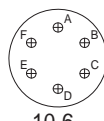

10-6
6X #20

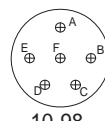

10-98
6X #20

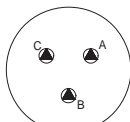

12-3
3X #16

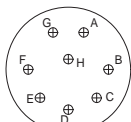

12-8
8X #20

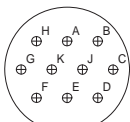

12-10
10X #20

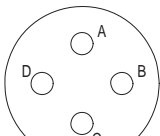

14-4
4X #12

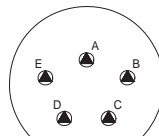

14-5
5X #16

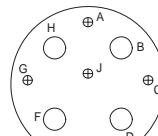

14-9
4X #12/5X #20

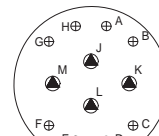

14-12
4X #16/8X #20

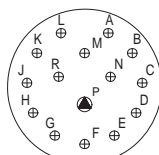

14-15
1X #16/14X #20

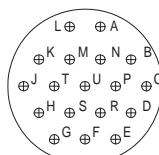

14-18
18X #20

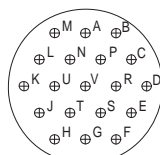

14-19
19X #20

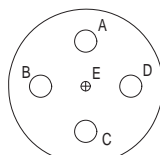

14-22
4X #12/1X #20

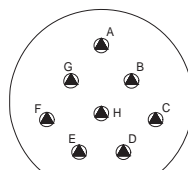

16-8
8X #16

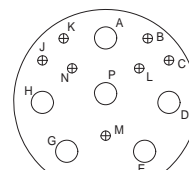

16-14
6X #12/8X #20

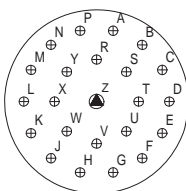

16-23
1X #16/22X #20

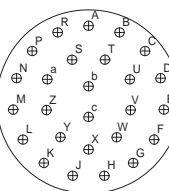

16-26
26X #20

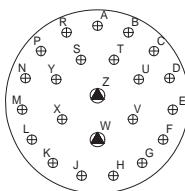

16-99
2X #16/21X #20

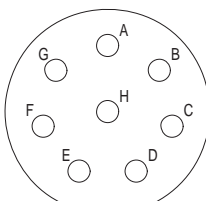

18-8
8X #12

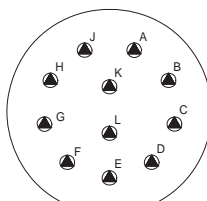

18-11
11X #16

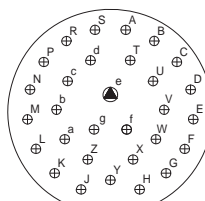

18-30
1X #16/29X #20

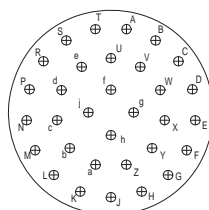

18-32
32X #20

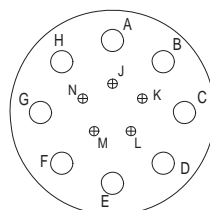

18-85
8X #12/5X #20

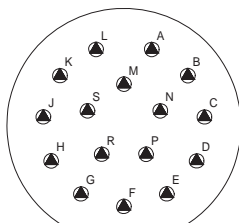

20-16
16X #16

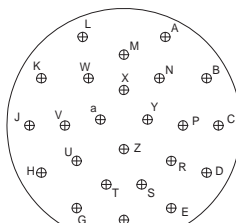

20-24
24X #20

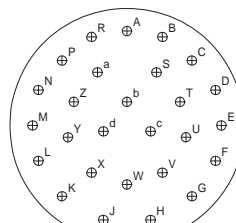

20-27
27X #20

SYM	SIZE
⊕	#20
▲	#16
○	#12

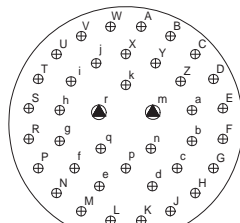

20-39
2X #16/37X #20

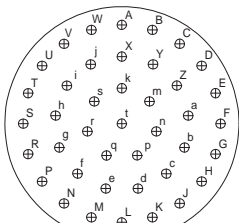

20-41
41X #20

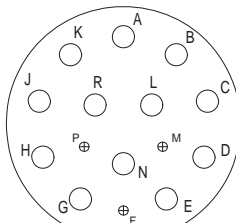

20-90
12X #12/3X #20

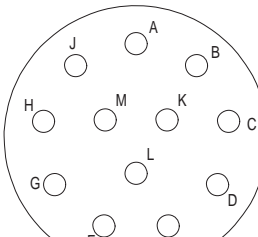

22-12
12X #12

Dimensions in inches (millimeters) and are subject to change without notice.

MIL-STD-1669 Insert Arrangements (Pin Front View) and Insert Positions for MIL-DTL-26482 Series II Type Filter Connectors



MIL-DTL-26482
Type

B

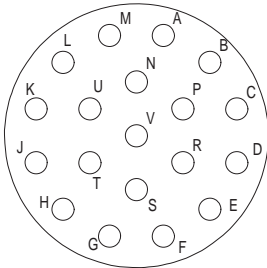

22-19
19X #12

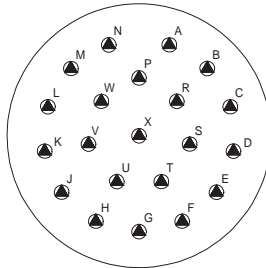

22-21
21X #16

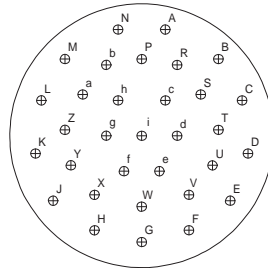

22-32
32X #20

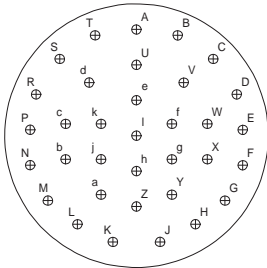

22-34
34X #20

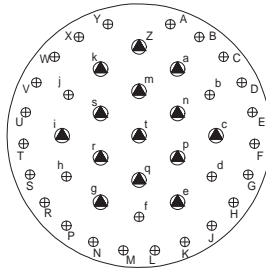

22-41
14X #16/27X #20

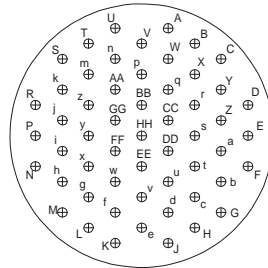

22-55
55X #20

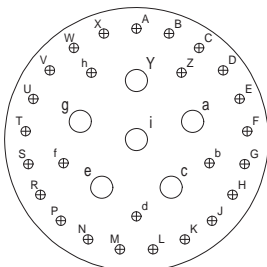

22-95
6X #12/26X #20

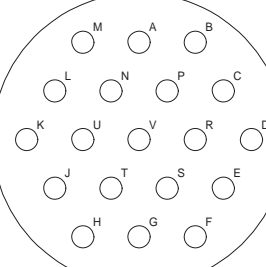

24-19
19X #12

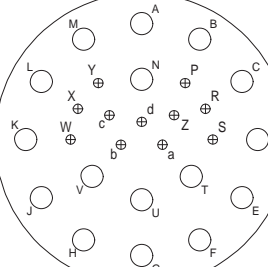

24-27
16X #12/11X #20

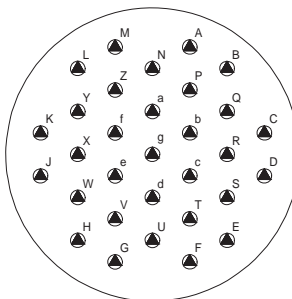

24-31
31X #16

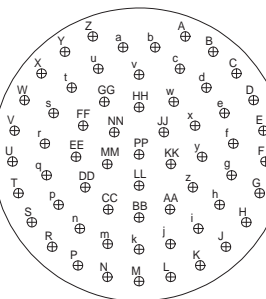

24-61
61X #20

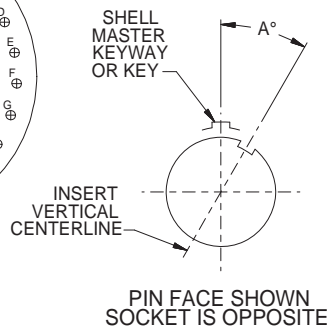

SYM	SIZE
⊕	#20
▲	#16
○	#12

NOTE: SHELL KEYS & KEYWAYS REMAIN FIXED WHILE THE INSERT IS ROTATED RELATIVE TO THE CENTERLINE OF THE MASTER KEY OR KEYWAY (POSITION N = 0°).

MIL-DTL-26482 Series II Insert Positions					
Insert Arrg.	A°				
	N°	W°	X°	Y°	Z°
8-2	0°	58°	122°	-	-
8-3	0°	60°	210°	-	-
8-4	0°	45°	-	-	-
8-33	0°	90°	-	-	-
8-98	0°	-	-	-	-
10-6	0°	90°	-	-	-
10-98	0°	90°	180°	240°	270°
12-3	0°	-	-	180°	-
12-8	0°	90°	112°	203°	292°
12-10	0°	60°	155°	270°	295°
14-4	0°	45°	-	-	-
14-5	0°	40°	92°	184°	273°
14-9	0°	15°	90°	180°	240°
14-12	0°	43°	90°	-	-
14-15	0°	17°	110°	155°	234°
14-18	0°	15°	90°	180°	270°
14-19	0°	30°	165°	315°	-
14-22	0°	45°	-	-	-
16-8	0°	54°	152°	180°	331°
16-14	0°	25°	78°	180°	240°
16-23	0°	158°	270°	-	-
16-26	0°	60°	-	275°	338°
16-99	0°	66°	156°	223°	340°
18-8	0°	180°	-	-	-
18-11	0°	62°	119°	241°	340°
18-30	0°	180°	193°	285°	350°
18-32	0°	85°	138°	222°	265°
18-85	0°	45°	90°	180°	240°
20-16	0°	238°	318°	333°	347°
20-24	0°	70°	145°	215°	290°
20-27	0°	72°	144°	216°	288°
20-39	0°	83°	144°	252°	333°
20-41	0°	45°	126°	225°	-
20-90	0°	18°	60°	240°	270°
22-12	0°	-	-	-	-
22-19	0°	15°	90°	225°	308°
22-21	0°	16°	135°	175°	349°
22-32	0°	72°	145°	215°	288°
22-34	0°	62°	142°	218°	298°
22-41	0°	39°	135°	264°	-
22-55	0°	30°	142°	226°	314°
22-95	0°	26°	180°	266°	-
24-19	0°	30°	165°	315°	-
24-27	0°	45°	110°	140°	225°
24-31	0°	90°	225°	255°	-
24-61	0°	90°	180°	270°	324°

Dimensions in inches (millimeters) and are subject to change without notice.

© 2013 Glenair, Inc.

U.S. CAGE Code 06324

Printed in U.S.A.



240-264W
MIL-DTL-26482 Series II Type Filter Connector
Wall Mount Receptacle, Narrow Flange

B

MIL-DTL-26482 SERIES II TYPE WALL MOUNT RECEPTACLE, NARROW FLANGE

How To Order										
Sample Part Number	240-264	W	ME	16-26	P	S	P	A	H	N
Filter Connector	MIL-DTL-26482 Series II Type									
Shell Style	W = Wall Mount									
Connector Class	See Table I									
Insert Arrangement	IAW MIL-STD-1669. (See pages B-62 – B-63)									
Contact Gender	P = Pin S = Socket									
Termination	P = PC Tail S = Solder Cup									
Filter Type	P = Pi Circuit C = C Circuit (See Note 1)									
Capacitance	See Table II									
Flange Mounting Style	H = Round Holes C = Clinch Nuts (4-40 UNC) M = Metric Clinch Nuts (M3)									
Alternate Insert Position	W, X, Y, Z, N = Normal (See page B-63)									

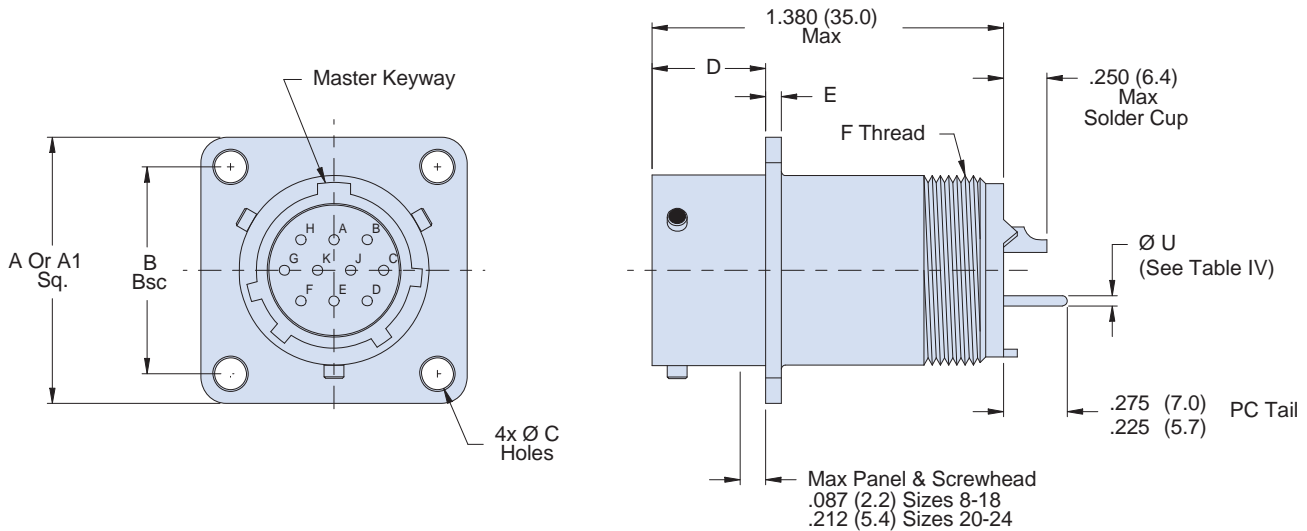

Notes

1. Other filter styles (C-L, L-C, Unbalanced Pi, Multi-Stage, Multi-Value) are available, please consult the factory.

Dimensions in inches (millimeters) and are subject to change without notice.

240-264W
MIL-DTL-26482 Series II Type Filter Connector
Wall Mount Receptacle, Narrow Flange



MIL-DTL-26482
Type

B

Table I: Connector Class

Sym	Class	Material	Finish Description
ME	Environmental	Aluminum	Electroless Nickel
MT	Environmental	Aluminum	Ni-PTFE 1000 Hour Grey™ Nickel Fluorocarbon Polymer
NF	Environmental	Aluminum	Cadmium O.D. Over Electroless Nickel
ZL	Environmental	Stainless Steel	Electro-Deposited Nickel
ZN	Environmental	Aluminum	Zinc-Nickel, Olive Drab
ZR	Environmental	Aluminum	Zinc Nickel, Black - RoHS
H2*	Hermetic	Stainless Steel	Electro-Deposited Nickel

*Some dimensions do not apply. See drawing 240-264WH2

Table II: Capacitor Array Code Capacitance Range

Class	Pi - Circuit (pF)	C - Circuit (pF)
X*	160,000 - 240,000	80,000 - 120,000
Y*	80,000 - 120,000	40,000 - 60,000
Z*	60,000 - 90,000	30,000 - 45,000
A	38,000 - 56,000	19,000 - 28,000
B	32,000 - 45,000	16,000 - 22,500
C	18,000 - 33,000	9,000 - 16,500
D	8,000 - 12,000	4,000 - 6,000
E	3,300 - 5,000	1,650 - 2,500
F	800 - 1,300	400 - 650
G	400 - 600	200 - 300
J	70-120	35-60

* Filter Classes X, Y and Z are 250 VDC.
All others are 500 VDC

Table IV: PC Tail Dia

Contact Size	Ø U
20	.031 (0.79)
	.029 (0.74)
16	.042 (1.07)
	.038 (0.97)
12	.096 (2.44)
	.092 (2.34)

Table III: Dimensions

Shell Size	Thru Hole Flange		Clinch Nut Flange	B Bsc	D	E	F Thread
	A Sq. Typ	Ø C ±.005 (.13)	A1 Sq. ±.020 (.51)				
8	.828 (21.0)	.120 (3.0)	.895 (22.7)	.594 (15.1)	.462 (11.7) .431 (11.0)	.078 (2.0) .046 (1.2)	.5000-20 UNF-2A
10	.954 (24.2)	.120 (3.0)	1.019 (25.9)	.719 (18.3)	.462 (11.7) .431 (11.0)	.078 (2.0) .046 (1.2)	.6250-24 UNEF-2A
12	1.047 (26.6)	.120 (3.0)	1.112 (28.2)	.812 (20.6)	.462 (11.7) .431 (11.0)	.078 (2.0) .046 (1.2)	.7500-20 UNEF-2A
14	1.141 (29.0)	.120 (3.0)	1.206 (30.6)	.906 (23.0)	.462 (11.7) .431 (11.0)	.078 (2.0) .046 (1.2)	.8750-20 UNEF-2A
16	1.234 (31.3)	.120 (3.0)	1.269 (32.2)	.969 (24.6)	.462 (11.7) .431 (11.0)	.078 (2.0) .046 (1.2)	1.0000-20 UNEF-2A
18	1.328 (33.7)	.120 (3.0)	1.362 (34.6)	1.062 (27.0)	.462 (11.7) .431 (11.0)	.078 (2.0) .046 (1.2)	1.0625-18 UNEF-2A
20	1.453 (39.9)	.120 (3.0)	1.456 (37.0)	1.156 (29.4)	.587 (14.9) .556 (14.1)	.110 (2.8) .078 (2.0)	1.1875-18 UNEF-2A
22	1.578 (40.1)	.120 (3.0)	1.562 (39.7)	1.250 (31.8)	.587 (14.9) .556 (14.1)	.110 (2.8) .078 (2.0)	1.3125-18 UNEF-2A
24	1.703 (43.3)	.147 (3.7)	1.719 (43.7)	1.375 (34.9)	.620 (15.8) .589 (15.0)	.110 (2.8) .078 (2.0)	1.4375-18 UNEF-2A

Dimensions in inches (millimeters) and are subject to change without notice.

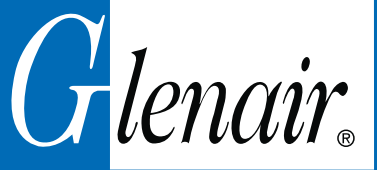

240-264J
MIL-DTL-26482 Series II Type Filter Connector
Jam Nut Receptacle

B

MIL-DTL-26482 SERIES II TYPE JAM NUT RECEPTACLE

How To Order										
Sample Part Number	240-264	J	ME	10-6	P	S	P	A	N	N
Filter Connector	MIL-DTL-26482 Series II Type									
Shell Style	J = Jam Nut									
Connector Class	See Table I									
Insert Arrangement	IAW MIL-STD-1669. (See pages B-62 – B-63)									
Contact Gender	P = Pin S = Socket									
Termination	P = PC Tail S = Solder Cup									
Filter Type	P = Pi Circuit C = C Circuit (See Note 1)									
Capacitance	See Table II									
Flange Mounting Style	N = Not Applicable									
Alternate Insert Position	W, X, Y, Z, N = Normal (See page B-63)									

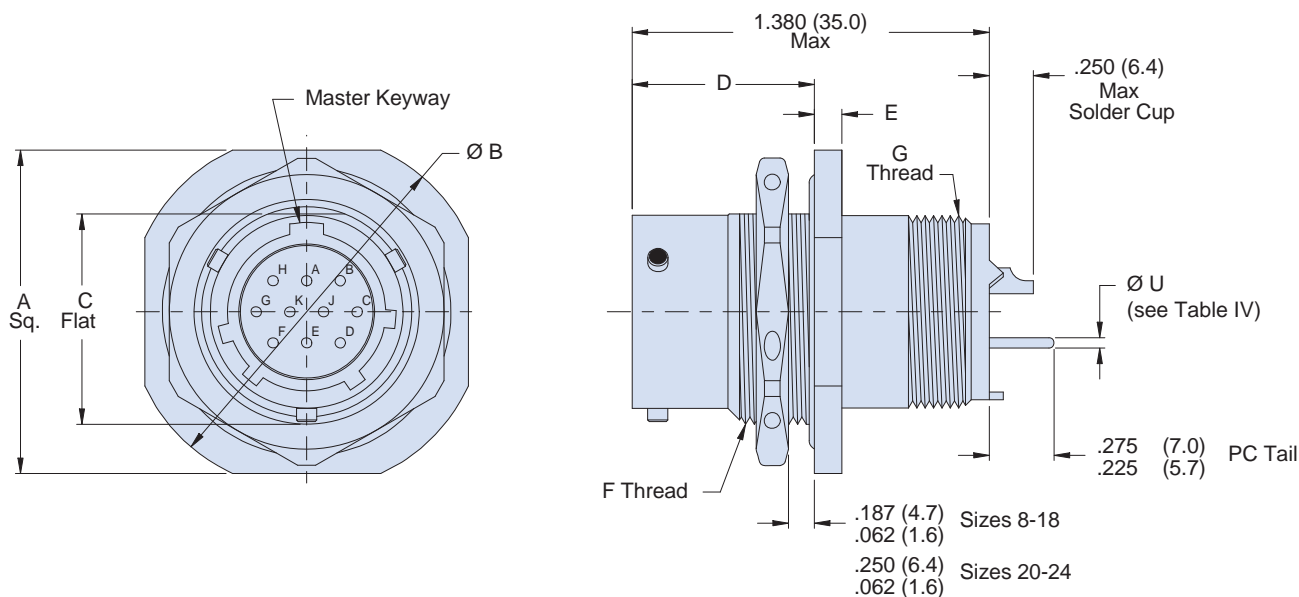

Notes

1. Other filter styles (C-L, L-C, Unbalanced Pi, Multi-Stage, Multi-Value) are available, please consult the factory.

Dimensions in inches (millimeters) and are subject to change without notice.

240-264J
MIL-DTL-26482 Series II Type Filter Connector
Jam Nut Receptacle



MIL-DTL-26482
Type

B

Sym	Class	Material	Finish Description
ME	Environmental	Aluminum	Electroless Nickel
MT	Environmental	Aluminum	Ni-PTFE 1000 Hour Grey™ Nickel Fluorocarbon Polymer
NF	Environmental	Aluminum	Cadmium O.D. Over Electroless Nickel
ZL	Environmental	Stainless Steel	Electro-Deposited Nickel
ZN	Environmental	Aluminum	Zinc-Nickel, Olive Drab
ZR	Environmental	Aluminum	Zinc Nickel, Black - RoHS
H2*	Hermetic	Stainless Steel	Electro-Deposited Nickel

*Some dimensions do not apply. See drawing 240-264JH2

Class	Pi - Circuit (pF)	C - Circuit (pF)
X*	160,000 - 240,000	80,000 - 120,000
Y*	80,000 - 120,000	40,000 - 60,000
Z*	60,000 - 90,000	30,000 - 45,000
A	38,000 - 56,000	19,000 - 28,000
B	32,000 - 45,000	16,000 - 22,500
C	18,000 - 33,000	9,000 - 16,500
D	8,000 - 12,000	4,000 - 6,000
E	3,300 - 5,000	1,650 - 2,500
F	800 - 1,300	400 - 650
G	400 - 600	200 - 300
J	70-120	35-60

* Filter Classes X, Y and Z are 250 VDC.
All others are 500 VDC

Contact Size	Ø U
20	.031 (0.79)
	.029 (0.74)
16	.042 (1.07)
	.038 (0.97)
12	.096 (2.44)
	.092 (2.34)

Shell Size	A Sq.	Ø B	C Flat ±.005 (.13)	D	E	F Thread	G Thread
8	.954 (24.2)	1.078 (27.4)	.525 (13.3)	.707 (18.0)	.113 (2.9)	.5625-24 UNEF-2A	.5000-20 UNF-2A
	.923 (23.4)	1.047 (26.6)		.658 (17.6)	.086 (2.2)		
10	1.078 (27.4)	1.203 (30.6)	.650 (16.5)	.707 (18.0)	.113 (2.9)	.6875-24 UNEF-2A	.6250-24 UNEF-2A
	1.047 (26.6)	1.172 (29.8)		.658 (17.6)	.086 (2.2)		
12	1.266 (32.2)	1.391 (35.3)	.813 (20.6)	.707 (18.0)	.113 (2.9)	.8750-20 UNEF-2A	.7500-20 UNEF-2A
	1.235 (31.4)	1.360 (34.5)		.658 (17.6)	.086 (2.2)		
14	1.391 (35.3)	1.516 (38.6)	.937 (23.8)	.707 (18.0)	.113 (2.9)	1.0000-20 UNEF-2A	.8750-20 UNEF-2A
	1.360 (34.5)	1.485 (37.7)		.658 (17.6)	.086 (2.2)		
16	1.516 (38.5)	1.641 (41.7)	1.061 (27.0)	.707 (18.0)	.113 (2.9)	1.1250-18 UNEF-2A	1.0000-20 UNEF-2A
	1.485 (37.7)	1.610 (40.9)		.658 (17.6)	.086 (2.2)		
18	1.641 (41.7)	1.766 (44.9)	1.186 (30.1)	.707 (18.0)	.113 (2.9)	1.2500-18 UNEF-2A	1.0625-18 UNEF-2A
	1.610 (40.9)	1.735 (44.1)		.658 (17.6)	.086 (2.2)		
20	1.828 (46.6)	1.954 (49.6)	1.311 (33.3)	.772 (19.6)	.148 (3.8)	1.3750-18 UNEF-2A	1.1875-18 UNEF-2A
	1.797 (45.6)	1.923 (48.8)		.721 (18.3)	.096 (2.4)		
22	1.954 (49.6)	2.078 (52.8)	1.436 (36.5)	.772 (19.6)	.148 (3.8)	1.5000-18 UNEF-2A	1.3125-18 UNEF-2A
	1.923 (48.8)	2.047 (52.0)		.721 (18.3)	.096 (2.4)		
24	2.078 (52.8)	2.203 (56.0)	1.561 (39.7)	.772 (19.6)	.148 (3.8)	1.6250-18 UNEF-2A	1.4375-18 UNEF-2A
	2.047 (52.0)	2.172 (55.2)		.721 (18.3)	.096 (2.4)		

Dimensions in inches (millimeters) and are subject to change without notice.

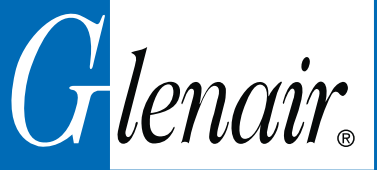

240-264A
MIL-DTL-26482 Series II Type Filter Connector
Connector Adapter

B

MIL-DTL-26482 SERIES II TYPE CONNECTOR ADAPTER

How To Order									
Sample Part Number	240-264	A	ME	16-26	PS	P	A	N	N
Filter Connector	MIL-DTL-26482 Series II Type								
Shell Style	A = Connector Adapter								
Connector Class	See Table I								
Insert Arrangement	IAW MIL-STD-1669. (See pages B-62 – B-63)								
Contact Gender	PS = Pins, Plug Side SP = Sockets, Plug Side (See Note 2)								
Filter Type	P = Pi Circuit C = C Circuit (See Note 1)								
Capacitance	See Table II								
Flange Mounting Style	N = Not Applicable								
Alternate Insert Position	W, X, Y, Z, N = Normal (See page B-63)								

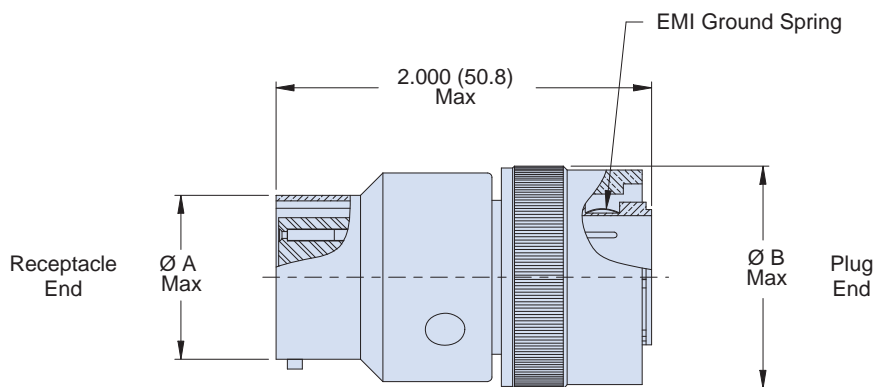

Notes

1. Other filter styles (C-L, L-C, Unbalanced Pi, Multi-Stage, Multi-Value) are available, please consult the factory.
2. Please consult the factory for Pin/Pin and/or Socket/Socket contact arrangements.

Dimensions in inches (millimeters) and are subject to change without notice.

240-264A
MIL-DTL-26482 Series II Type Filter Connector
Connector Adapter



MIL-DTL-26482
Type

B

Table I: Connector Class

Sym	Class	Material	Finish Description
ME	Environmental	Aluminum	Electroless Nickel
MT	Environmental	Aluminum	Ni-PTFE 1000 Hour Grey™ Nickel Fluorocarbon Polymer
NF	Environmental	Aluminum	Cadmium O.D. Over Electroless Nickel
ZL	Environmental	Stainless Steel	Electro-Deposited Nickel
ZN	Environmental	Aluminum	Zinc-Nickel, Olive Drab
ZR	Environmental	Aluminum	Zinc Nickel, Black - RoHS

Table II: Capacitor Array Code Capacitance Range

Class	Pi - Circuit (pF)	C - Circuit (pF)
X*	160,000 - 240,000	80,000 - 120,000
Y*	80,000 - 120,000	40,000 - 60,000
Z*	60,000 - 90,000	30,000 - 45,000
A	38,000 - 56,000	19,000 - 28,000
B	32,000 - 45,000	16,000 - 22,500
C	18,000 - 33,000	9,000 - 16,500
D	8,000 - 12,000	4,000 - 6,000
E	3,300 - 5,000	1,650 - 2,500
F	800 - 1,300	400 - 650
G	400 - 600	200 - 300
J	70-120	35-60

* Filter Classes X, Y and Z are 250 VDC.
All others are 500 VDC

Table III: Dimensions

Shell Size	ØA Max	ØB Max
8	.474 (12.0)	.784 (19.9)
10	.591 (15.0)	.926 (23.5)
12	.751 (19.1)	1.043 (26.5)
14	.876 (22.3)	1.183 (30.0)
16	1.001 (25.4)	1.305 (33.1)
18	1.126 (28.6)	1.391 (35.3)
20	1.251 (31.8)	1.531 (38.9)
22	1.376 (35.0)	1.656 (42.1)
24	1.501 (38.1)	1.777 (45.1)

Dimensions in inches (millimeters) and are subject to change without notice.

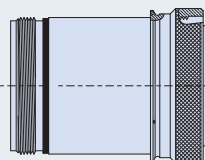
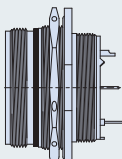
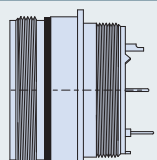
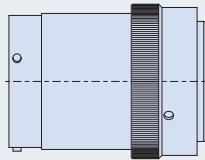
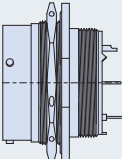
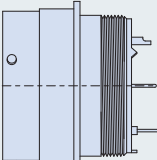
	240-837A	Connector Adapters Threaded Coupling	Page B-74
	240-837J	Jam Nut Receptacles Threaded Coupling	Page B-76
	240-837W	Wall Mount Receptacles Threaded Coupling	Page B-78
	240-838A	<i>New!</i> Connector Adapters Bayonet Coupling	Page B-80
	240-838J	<i>New!</i> Jam Nut Receptacles Bayonet Coupling	Page B-82
	240-838W	<i>New!</i> Wall Mount Receptacles Bayonet Coupling	Page B-84

Notes

1. Materials/Finishes: Shells, Barrel, Coupling Nut, Jam Nut - See Table I
Insulators - high grade rigid dielectric/N.A.
Seals - Fluorosilicone
Contacts: Copper alloy 50 μ " Gold over 50 μ " Nickel
2. Assembly to be identified with Glenair's name, part number, and date code - space permitting.
3. Insert Arrangement in accordance with MIL-STD-1554. (Arrangement shown for reference only)
4. EMI Circular Filter Receptacle connectors designed to meet requirements of MIL-STD-2120 and MIL-DTL-83723, Series III.
5. All contacts to have identical filter value. Other filter arrangements available, contact factory.
6. Electrical Ratings: DWV- 500 VDC; Standard Operating Voltage 200 VDC (Filter class X, Y and Z are 250 VDC)
7. Insulation Resistance: 5000 MegOhms Min. at 200 VDC.
8. Operating Temperature -55°C to +125°C (Env Class Connectors)
9. Other filter styles (C-L, L-C, Unbalanced Pi, Multi-Stage, Multi-Value) are available, please consult the factory.

Dimensions in inches (millimeters) and are subject to change without notice.

MIL-DTL-83723 Series III Type Filter Connectors Panel Cutouts



MIL-DTL-83723
Type

B

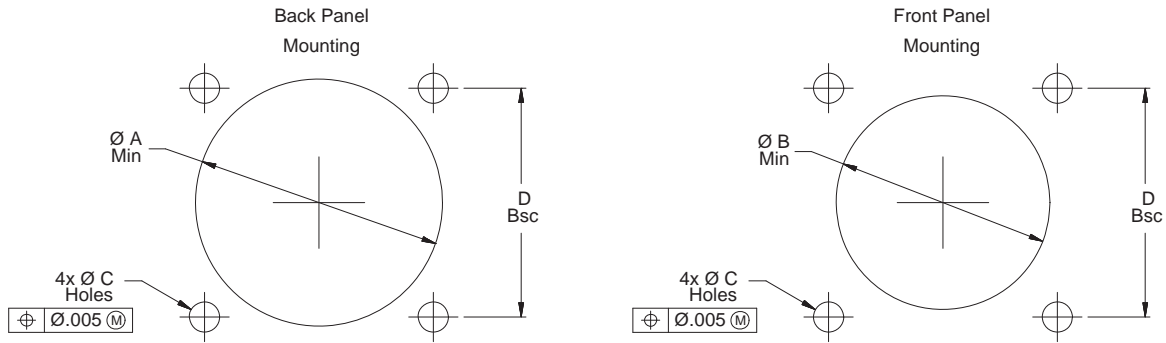

MIL-DTL-83723 Series III Square Flange Panel Cut-Outs				
Shell Size	Ø A Min Back Panel	Ø B Min Front Panel	Ø C Holes	D Bsc
8	.620 (15.8)	.510 (13.0)	.125 (3.2) .116 (2.9)	.594 (15.1)
10	.748 (19.0)	.635 (16.1)		.719 (18.3)
12	.918 (23.3)	.760 (19.3)		.812 (20.6)
14	.988 (25.1)	.885 (22.5)		.906 (23.0)
16	1.114 (28.3)	1.010 (25.7)		.969 (24.6)
18	1.220 (40.0)	1.072 (27.2)		1.062 (27.0)
20	1.346 (34.2)	1.197 (30.4)		1.156 (29.4)
22	1.470 (37.3)	1.322 (33.6)	1.250 (31.8)	
24	1.596 (40.5)	1.442 (36.6)	.154 (3.9) .145 (3.7)	1.375 (34.9)

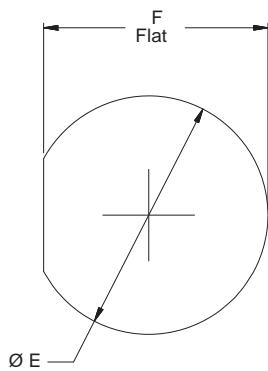

MIL-DTL-83723 Series III Jam Nut Panel Cut-Out		
Shell Size	Ø E	F Flat
8	.640 (16.3)	.610 (15.5)
	.630 (16.0)	.600 (15.2)
10	.765 (19.4)	.735 (18.7)
	.755 (19.2)	.725 (18.4)
12	.952 (24.2)	.922 (23.4)
	.942 (23.9)	.912 (23.2)
14	1.015 (25.8)	.985 (25.0)
	1.005 (25.5)	.975 (24.8)
16	1.140 (29.0)	1.110 (28.2)
	1.130 (28.7)	1.100 (27.9)
18	1.265 (32.1)	1.234 (31.3)
	1.255 (31.9)	1.224 (31.1)
20	1.390 (35.3)	1.359 (34.5)
	1.380 (35.1)	1.349 (34.3)
22	1.515 (38.5)	1.484 (37.7)
	1.505 (38.2)	1.474 (37.4)
24	1.640 (41.7)	1.609 (40.9)
	1.630 (41.4)	1.599 (40.6)

Dimensions in inches (millimeters) and are subject to change without notice.

MIL-STD-1554 Insert Arrangements (Socket Front View) and Polarization (Shell Keying, Insert Clocking) for MIL-DTL-83723 Series III Type Filter Connectors

B

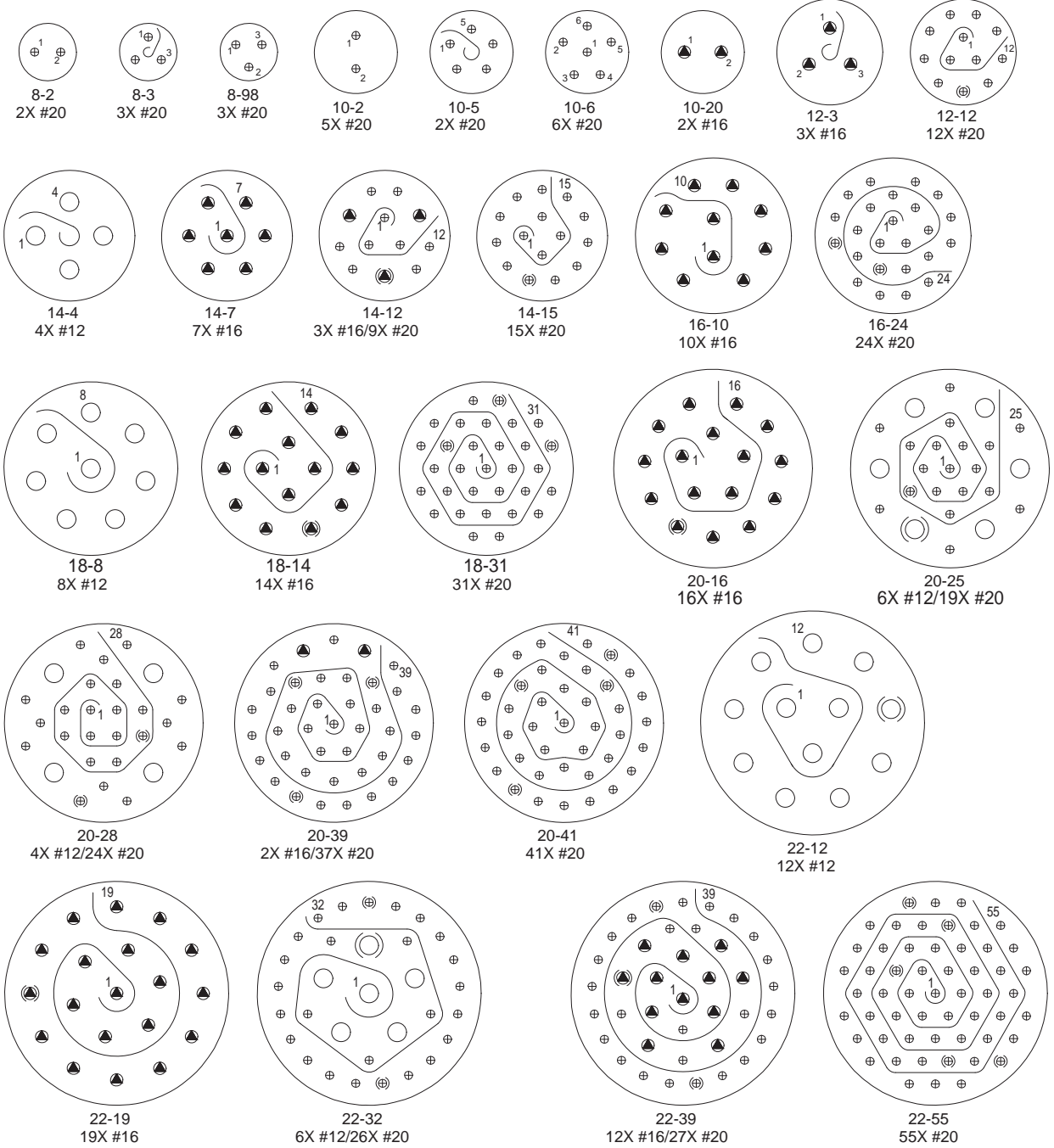

SYM	SIZE
⊕	#20
●	#16
○	#12

Dimensions in inches (millimeters) and are subject to change without notice.

MIL-STD-1554 Insert Arrangements (Socket Front View) and Polarization (Shell Keying, Insert Clocking) for MIL-DTL-83723 Series III Type Filter Connectors



MIL-DTL-83723
Type

B

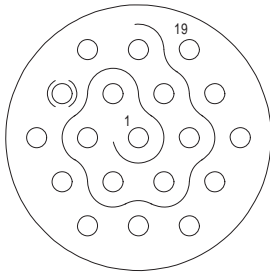

24-19
19x #12

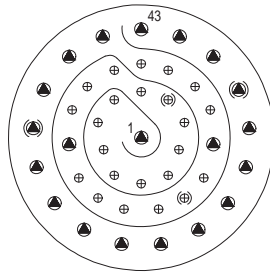

24-43
20x #16/23x #20

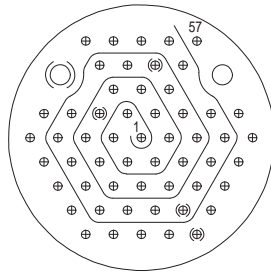

24-57
2x #12/55x #20

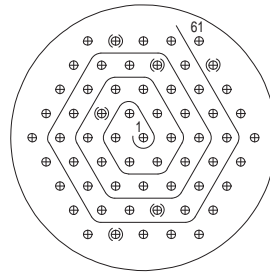

24-61
61x #20

SYM	SIZE
⊕	#20
⊖	#16
○	#12

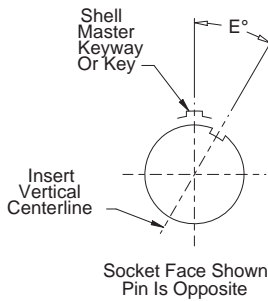
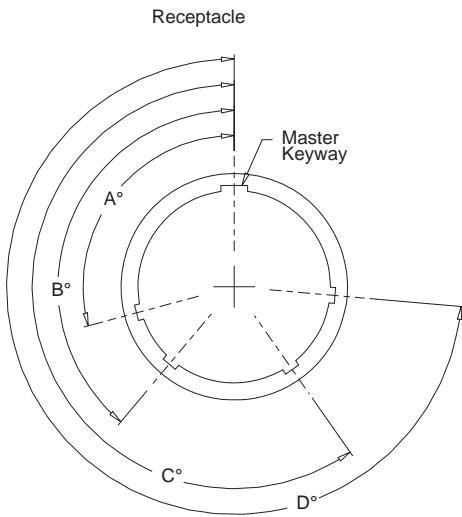

MIL-DTL-83723 Series III Shell Keying, Insert Clocking						
Shell Size	Polarizing Position	Key/Keyway Positions				Insert Position
		A° Bsc	B° Bsc	C° Bsc	D° Bsc	E° Bsc
8 10	N	105°	140°	215°	265°	0°
	6	102°	132°	248°	320°	0°
	7	80°	118°	230°	312°	0°
	8	35°	140°	205°	275°	0°
	9	64°	155°	234°	304°	0°
10 Only	Y	25°	115°	220°	270°	0°
12 Thru 24	N	105°	140°	215°	265°	0°
	6	18°	149°	192°	259°	0°
	7	92°	152°	222°	342°	0°
	8	84°	152°	204°	334°	0°
	9	24°	135°	199°	240°	0°
10 Thru 24 <i>Inactive for New Design</i>	Y	98°	152°	268°	338°	0°
	1	105°	140°	215°	265°	10°
	2	105°	140°	215°	265°	20°
	3	105°	140°	215°	265°	30°
	4	105°	140°	215°	265°	40°
	5	105°	140°	215°	265°	50°

Note: In the alternate keying positions (6, 7, 8, 9 & Y), the minor keys or keyways are positioned with reference to master key or keyway as indicated. In the insert clocking positions (1, 2, 3, 4 & 5), the socket insert is rotated clockwise relative to the master key or keyway, and the pin insert is rotated counter-clockwise relative to the master key or keyway.

Dimensions in inches (millimeters) and are subject to change without notice.

© 2013 Glenair, Inc.

U.S. CAGE Code 06324

Printed in U.S.A.

MIL-DTL-83723 SERIES III TYPE -WALL MOUNT RECEPTACLE

How To Order									
Sample Part Number	240-837	A	ME	24-61	PS	P	A	N	N
Filter Connector	MIL-DTL-83723 Series III Type, Threaded Coupling								
Shell Style	A = Connector Adapter								
Connector Class	See Table I								
Insert Arrangement	IAW MIL-STD-1554. (See pages B-72 – B-73)								
Contact Gender	PS = Pins, Plug Side SP = Sockets, Plug Side (See Note 2)								
Filter Type	P = Pi Circuit C = C Circuit (See Note 1)								
Capacitance	See Table II								
Flange Mounting Style	N = Not Applicable								
Alternate Insert Position	IAW MIL-DTL-83723 and MIL-STD-1554 1, 2, 3, 4, 5, 6, 7, 8, 9, Y, N = Normal (See page B-73)								

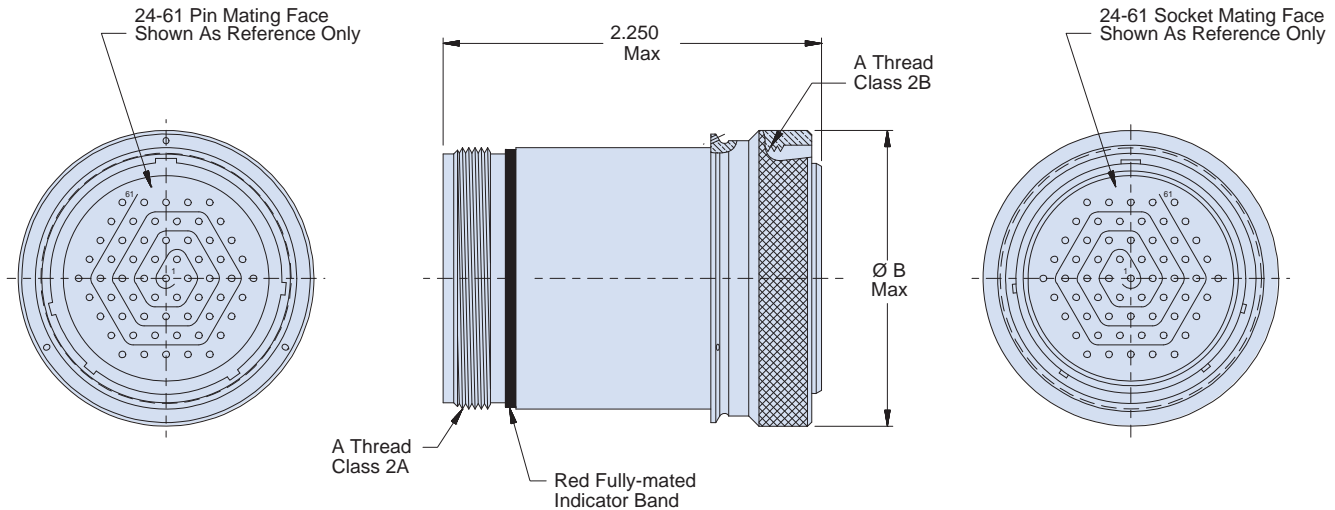
Notes

- Other filter styles (C-L, L-C, Unbalanced Pi, Multi-Stage, Multi-Value) are available, please consult the factory.
- Please consult the factory for Pin/Pin and/or Socket/Socket contact arrangements.

Dimensions in inches (millimeters) and are subject to change without notice.

240-837A
MIL-DTL-83723 Series III Type
Filtered Connector Adapter, Threaded Coupling



MIL-DTL-83723
Type

B

Table I: Connector Class		
Sym	Material	Finish Description
ME	Aluminum	Electroless Nickel
MT	Aluminum	Ni-PTFE 1000 Hour Grey™ Nickel Fluorocarbon Polymer
NF	Aluminum	Cadmium O.D. Over Electroless Nickel
ZL	Stainless Steel	Electro-Deposited Nickel
ZN	Aluminum	Zinc-Nickel, Olive Drab
ZR	Aluminum	Zinc Nickel, Black - RoHS

Table II: Capacitor Array Code Capacitance Range		
Class	Pi - Circuit (pF)	C - Circuit (pF)
X*	160,000 - 240,000	80,000 - 120,000
Y*	80,000 - 120,000	40,000 - 60,000
Z*	60,000 - 90,000	30,000 - 45,000
A	38,000 - 56,000	19,000 - 28,000
B	32,000 - 45,000	16,000 - 22,500
C	18,000 - 33,000	9,000 - 16,500
D	8,000 - 12,000	4,000 - 6,000
E	3,300 - 5,000	1,650 - 2,500
F	800 - 1,300	400 - 650
G	400 - 600	200 - 300
J	70-120	35-60

* Filter Classes X, Y and Z are 250 VDC.
All others are 500 VDC

TABLE III: Dimensions		
Shell Size	A Thread	Ø B
8	.562-24 UNEF	.776 (19.7)
10	.688-24 UNEF	.906 (23.0)
12	.875-20 UNEF	1.078 (27.4)
14	.938-20 UNEF	1.141 (29.0)
16	1.062-18 UNEF	1.266 (32.2)
18	1.188-18 UNEF	1.375 (34.9)
20	1.312-18 UNEF	1.510 (38.4)
22	1.438-18 UNEF	1.625 (41.3)
24	1.562-18 UNEF	1.760 (44.7)

Dimensions in inches (millimeters) and are subject to change without notice.

MIL-DTL-83723 SERIES III TYPE JAM NUT RECEPTACLE, THREADED COUPLING

How To Order	
Sample Part Number	240-837 J ME 24-61 P S P A N N
Filter Connector	MIL-DTL-83723 Series III Type, threaded coupling
Shell Style	J = Jam Nut
Connector Class	See Table I
Insert Arrangement	IAW MIL-STD-1554. (See pages B-72 – B-73)
Contact Gender	P = Pin IAW D83723/85 S = Socket IAW D83723/84
Termination	S = Solder Cup P = PC Tail, Straight T = PC Tail, with Shoulder
Filter Type	P = Pi Circuit C = C Circuit (See Note 1)
Capacitance	See Table II
Flange Mounting Style	N = Not Applicable
Alternate Insert Position	IAW MIL-DTL-83723 and MIL-STD-1554 1, 2, 3, 4, 5, 6, 7, 8, 9, Y, N = Normal (See page B-73)

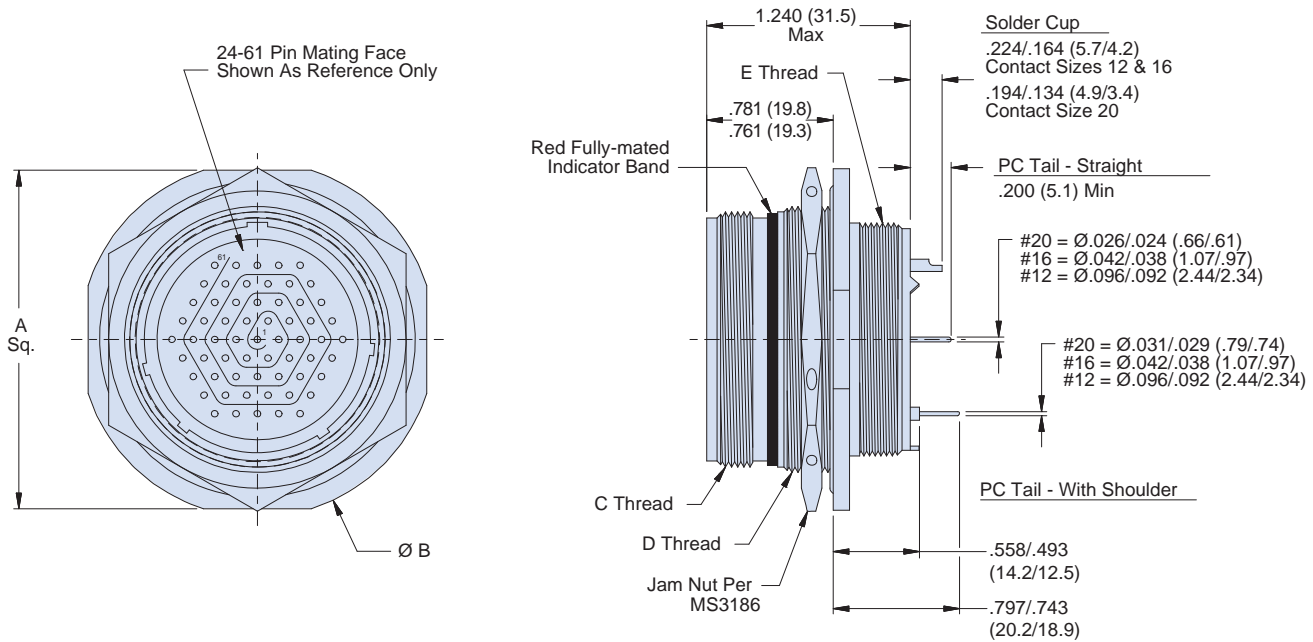
Notes

- Other filter styles (C-L, L-C, Unbalanced Pi, Multi-Stage, Multi-Value) are available, please consult the factory.

Dimensions in inches (millimeters) and are subject to change without notice.

240-837J
MIL-DTL-83723 Series III Type
Jam Nut Receptacle, Threaded Coupling

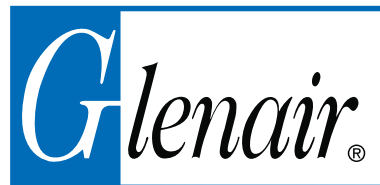

MIL-DTL-83723
Type

B

Sym	Material	Finish Description
ME	Aluminum	Electroless Nickel
MT		Ni-PTFE 1000 Hour Grey™ Nickel Fluorocarbon Polymer
NF		Cadmium O.D. Over Electroless Nickel
ZL	Stainless Steel	Electro-Deposited Nickel
ZN	Aluminum	Zinc-Nickel, Olive Drab
ZR	Aluminum	Zinc Nickel, Black - RoHS
H2*	Stainless Steel	Electro-Deposited Nickel

*Some dimensions do not apply. See drawing 240-837JH2

Class	Pi - Circuit (pF)	C - Circuit (pF)
X*	160,000 - 240,000	80,000 - 120,000
Y*	80,000 - 120,000	40,000 - 60,000
Z*	60,000 - 90,000	30,000 - 45,000
A	38,000 - 56,000	19,000 - 28,000
B	32,000 - 45,000	16,000 - 22,500
C	18,000 - 33,000	9,000 - 16,500
D	8,000 - 12,000	4,000 - 6,000
E	3,300 - 5,000	1,650 - 2,500
F	800 - 1,300	400 - 650
G	400 - 600	200 - 300
J	70-120	35-60

* Filter Classes X, Y and Z are 250 VDC.
All others are 500 VDC

Shell Size	A SQ.	Ø B	C Thread UNEF-2A	D Thread -2A	E Thread -2A
8	.980 (24.9)	1.078 (27.4)	.562-24	.625-20 UN	.500-20 UNF
	.949 (24.1)	1.047 (26.6)			
10	1.104 (28.0)	1.192 (30.3)	.688-24	.750-20 UNEF	.625-24 UNEF
	1.073 (27.3)	1.161 (29.5)			
12	1.291 (32.8)	1.380 (35.1)	.875-20	.938-20 UNEF	.750-20 UNEF
	1.260 (32.0)	1.349 (34.3)			
14	1.391 (35.3)	1.561 (39.6)	.938-20	1.000-20 UNEF	.875-20 UNEF
	1.360 (34.5)	1.485 (37.7)			
16	1.516 (38.5)	1.641 (41.7)	1.062-18	1.125-18 UNEF	1.000-20 UNEF
	1.485 (37.7)	1.610 (40.9)			
18	1.641 (41.7)	1.766 (44.9)	1.188-18	1.250-18 UNEF	1.062-18 UNEF
	1.610 (40.9)	1.735 (44.1)			
20	1.766 (44.9)	1.954 (49.6)	1.312-18	1.375-18 UNEF	1.188-18 UNEF
	1.735 (44.1)	1.923 (48.8)			
22	1.954 (49.6)	2.078 (52.8)	1.438-18	1.500-18 UNEF	1.312-18 UNEF
	1.923 (48.8)	2.047 (52.0)			
24	2.079 (52.8)	2.182 (55.4)	1.562-18	1.625-18 UNEF	1.438-18 UNEF
	2.048 (52.0)	2.152 (54.7)			

Dimensions in inches (millimeters) and are subject to change without notice.

MIL-DTL-83723 SERIES III WALL MOUNT RECEPTACLE, THREADED COUPLING

How To Order										
Sample Part Number	240-837	W	ME	24-61	P	S	P	A	H	N
Filter Connector	MIL-DTL-83723 Series III Type, threaded coupling									
Shell Style	W = Wall Mount									
Connector Class	See Table I									
Insert Arrangement	IAW MIL-STD-1554. (See pages B-72 – B-73)									
Contact Gender	P = Pin IAW D83723/83 S = Socket IAW D83723/82									
Termination	S = Solder Cup P = PC Tail, Straight T = PC Tail, with Shoulder									
Filter Type	P = Pi Circuit C = C Circuit (See Note 1)									
Capacitance	See Table II									
Flange Mounting Style	H = Round Holes C = Clinch Nuts (4-40 UNC) M = Metric Clinch Nuts (M3)									
Alternate Insert Position	IAW MIL-DTL-83723 and MIL-STD-1554 1, 2, 3, 4, 5, 6, 7, 8, 9, Y, N = Normal (See page B-73)									

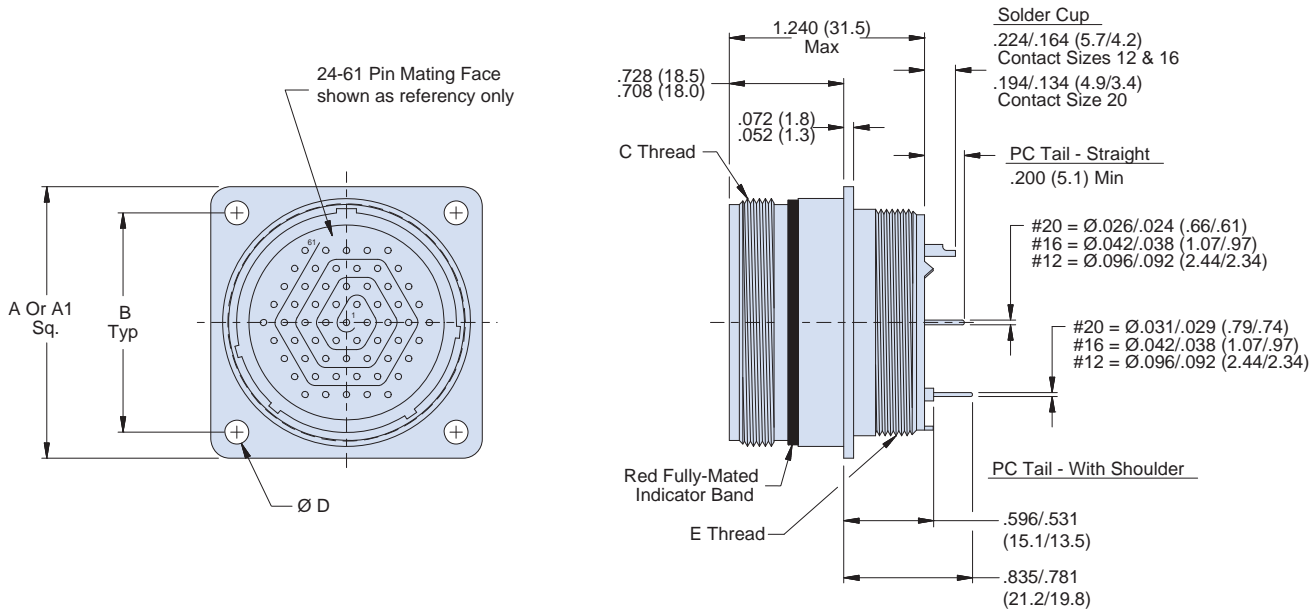
Notes

- Other filter styles (C-L, L-C, Unbalanced Pi, Multi-Stage, Multi-Value) are available, please consult the factory.

Dimensions in inches (millimeters) and are subject to change without notice.

240-837W
MIL-DTL-83723 Series III Type
Wall Mount Receptacle, Threaded Coupling



MIL-DTL-83723
Type

B

Sym	Material	Finish Description
ME	Aluminum	Electroless Nickel
MT		Ni-PTFE 1000 Hour Grey™ Nickel Fluorocarbon Polymer
NF		Cadmium O.D. Over Electroless Nickel
ZL	Stainless Steel	Electro-Deposited Nickel
ZN	Aluminum	Zinc-Nickel, Olive Drab
ZR	Aluminum	Zinc Nickel, Black - RoHS
H2*	Stainless Steel	Electro-Deposited Nickel

*Some dimensions do not apply. See drawing 240-837WH2

Class	Pi - Circuit (pF)	C - Circuit (pF)
X*	160,000 - 240,000	80,000 - 120,000
Y*	80,000 - 120,000	40,000 - 60,000
Z*	60,000 - 90,000	30,000 - 45,000
A	38,000 - 56,000	19,000 - 28,000
B	32,000 - 45,000	16,000 - 22,500
C	18,000 - 33,000	9,000 - 16,500
D	8,000 - 12,000	4,000 - 6,000
E	3,300 - 5,000	1,650 - 2,500
F	800 - 1,300	400 - 650
G	400 - 600	200 - 300
J	70-120	35-60

* Filter Classes X, Y and Z are 250 VDC.
All others are 500 VDC

Shell Size	Thru Hole Flange		Clinch Nut Flange A1 Sq. ±.020 (.51)	B Typ	C Thread	E Thread
	A Sq. Typ	Ø D				
8	.812 (20.6)	.125 (3.2) .116 (2.9)	.895 (22.7)	.594 (15.1)	.5625-24 UNEF-2A	.5000-20 UNF-2A
10	.937 (23.8)	.125 (3.2) .116 (2.9)	1.019 (25.9)	.719 (18.3)	.6875-24 UNEF-2A	.6250-24 UNEF-2A
12	1.031 (26.2)	.125 (3.2) .116 (2.9)	1.112 (28.2)	.812 (20.6)	.8750-20 UNEF-2A	.7500-20 UNEF-2A
14	1.125 (28.6)	.125 (3.2) .116 (2.9)	1.206 (30.6)	.906 (23.0)	.9375-20 UNEF-2A	.8750-20 UNEF-2A
16	1.250 (31.8)	.125 (3.2) .116 (2.9)	1.269 (32.2)	.969 (24.6)	1.0625-18 UNEF-2A	1.0000-20 UNEF-2A
18	1.343 (34.1)	.125 (3.2) .116 (2.9)	1.362 (34.6)	1.062 (27.0)	1.1875-18 UNEF-2A	1.0625-18 UNEF-2A
20	1.437 (36.5)	.125 (3.2) .116 (2.9)	1.456 (37.0)	1.156 (29.4)	1.3125-18 UNEF-2A	1.1875-18 UNEF-2A
22	1.562 (39.7)	.125 (3.2) .116 (2.9)	1.562 (39.7)	1.250 (31.8)	1.4375-18 UNEF-2A	1.3125-18 UNEF-2A
24	1.703 (43.3)	.154 (3.9) .145 (3.7)	1.719 (43.7)	1.375 (34.9)	1.5625-18 UNEF-2A	1.4375-18 UNEF-2A

Dimensions in inches (millimeters) and are subject to change without notice.

MIL-DTL-83723 SERIES III TYPE CONNECTOR ADAPTER, BAYONET COUPLING

How To Order									
Sample Part Number	240-838	A	ME	24-61	PS	P	A	N	N
Filter Connector	MIL-DTL-83723 Series III Type, Bayonet Coupling								
Shell Style	A = Bayonet Coupling								
Connector Class	See Table I								
Insert Arrangement	IAW MIL-STD-1554. (See pages B-72 – B-73)								
Contact Gender	PS = Pins, Plug Side SP = Sockets, Plug Side (See Note 2)								
Filter Type	P = Pi Circuit C = C Circuit (See Note 1)								
Capacitance	See Table II								
Flange Mounting Style	N = Not Applicable								
Alternate Insert Position	IAW MIL-DTL-83723 and MIL-STD-1554 1, 2, 3, 4, 5, 6, 7, 8, 9, Y, N = Normal (See page B-73)								

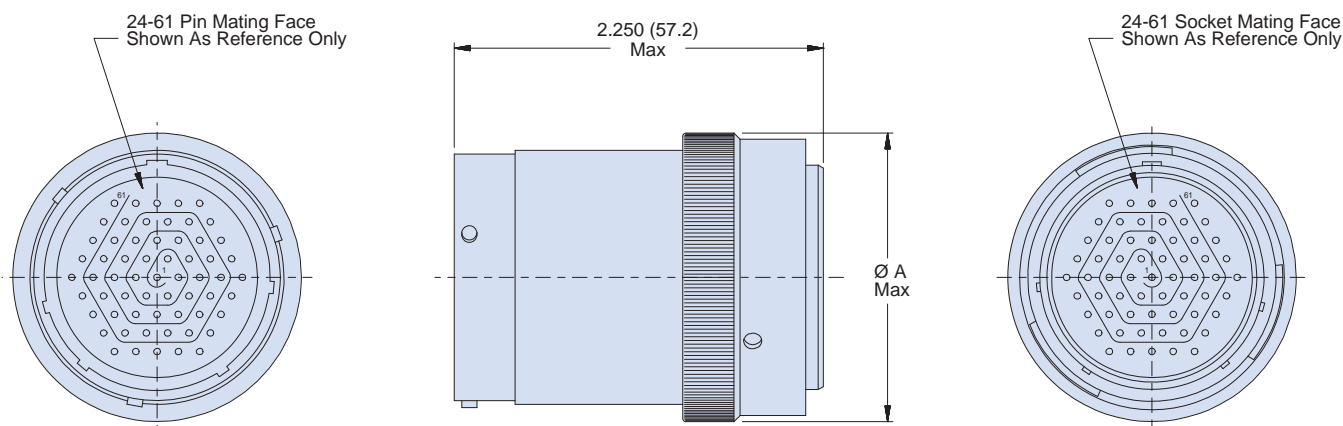
Notes

1. Other filter styles (C-L, L-C, Unbalanced Pi, Multi-Stage, Multi-Value) are available, please consult the factory.
2. Please consult the factory for Pin/Pin and/or Socket/Socket contact arrangements.

Dimensions in inches (millimeters) and are subject to change without notice.

240-838A
MIL-DTL-83723 Series III Type
Conector Adapter, Bayonet Coupling



MIL-DTL-83723
Type

B

Table I: Connector Class		
Sym	Material	Finish Description
ME	Aluminum	Electroless Nickel
MT		Ni-PTFE 1000 Hour Grey™ Nickel Fluorocarbon Polymer
NF		Cadmium O.D. Over Electroless Nickel
ZL	Stainless Steel	Electro-Deposited Nickel
ZN	Aluminum	Zinc-Nickel, Olive Drab
ZR	Aluminum	Zinc Nickel, Black - RoHS
H2*	Stainless Steel	Electro-Deposited Nickel

Table II: Capacitor Array Code Capacitance Range		
Class	Pi - Circuit (pF)	C - Circuit (pF)
X*	160,000 - 240,000	80,000 - 120,000
Y*	80,000 - 120,000	40,000 - 60,000
Z*	60,000 - 90,000	30,000 - 45,000
A	38,000 - 56,000	19,000 - 28,000
B	32,000 - 45,000	16,000 - 22,500
C	18,000 - 33,000	9,000 - 16,500
D	8,000 - 12,000	4,000 - 6,000
E	3,300 - 5,000	1,650 - 2,500
F	800 - 1,300	400 - 650
G	400 - 600	200 - 300
J	70-120	35-60

* Filter Classes X, Y and Z are 250 VDC.
All others are 500 VDC

Table III: Dimensions	
Shell Size	Ø A Max
8	.776 (19.7)
10	.906 (23.0)
12	1.708 (43.4)
14	1.141 (29.0)
16	1.266 (32.2)
18	1.375 (34.9)
20	1.510 (38.4)
22	1.625 (41.3)
24	1.760 (44.7)

Dimensions in inches (millimeters) and are subject to change without notice.

MIL-DTL-83723 SERIES III JAM NUT RECEPTACLE, BAYONET COUPLING

How To Order										
Sample Part Number	240-838	J	ME	24-61	P	S	P	A	N	N
Filter Connector	MIL-DTL-83723 Series III Type, Bayonet Coupling									
Shell Style	J = Jam Nut									
Connector Class	See Table I									
Insert Arrangement	IAW MIL-STD-1554. (See pages B-72 – B-73)									
Contact Gender	P = Pin IAW D83723/74 S = Socket IAW D83723/73									
Termination	S = Solder Cup P = PC Tail, Straight T = PC Tail, with Shoulder									
Filter Type	P = Pi Circuit C = C Circuit (See Note 1)									
Capacitance	See Table II									
Flange Mounting Style	N = Not Applicable									
Alternate Insert Position	IAW MIL-DTL-83723 and MIL-STD-1554 1, 2, 3, 4, 5, 6, 7, 8, 9, Y, N = Normal (See page B-73)									

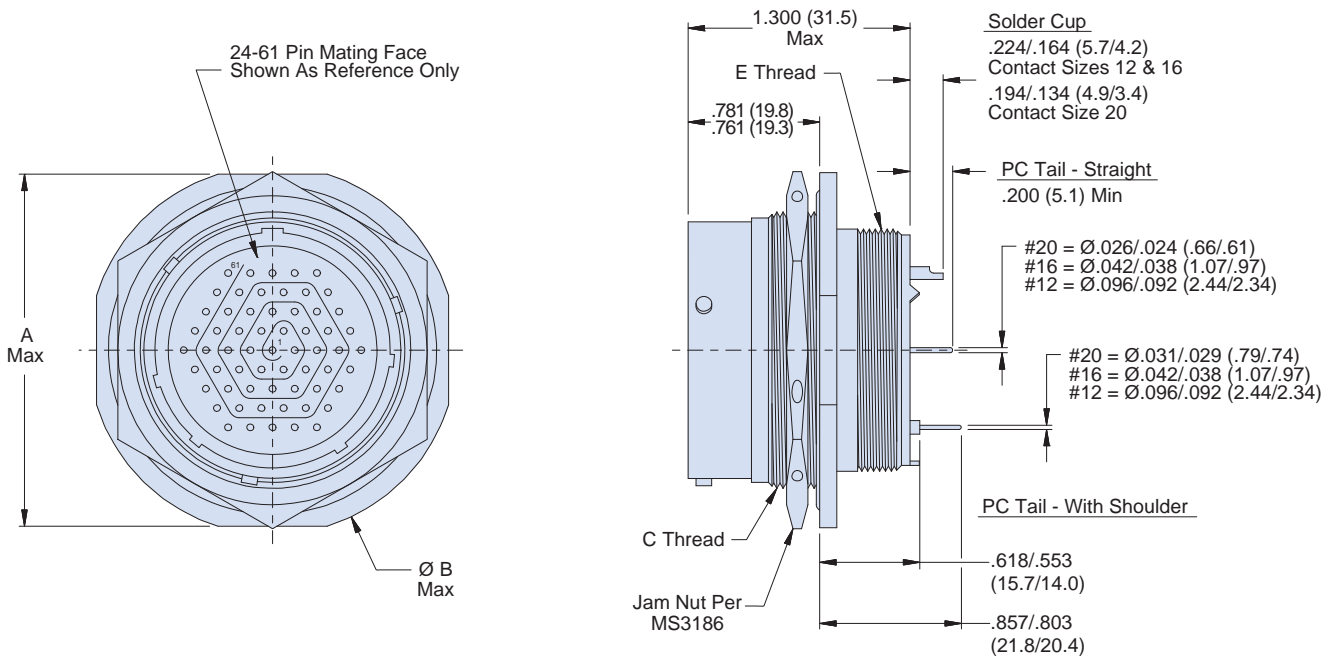
Notes

- Other filter styles (C-L, L-C, Unbalanced Pi, Multi-Stage, Multi-Value) are available, please consult the factory.

Dimensions in inches (millimeters) and are subject to change without notice.

240-838J
MIL-DTL-83723 Series III Type
Jam Nut Receptacle, Bayonet Coupling



MIL-DTL-83723
Type

B

Table I: Connector Class		
Sym	Material	Finish Description
ME	Aluminum	Electroless Nickel
MT		Ni-PTFE 1000 Hour Grey™ Nickel Fluorocarbon Polymer
NF		Cadmium O.D. Over Electroless Nickel
ZL	Stainless Steel	Electro-Deposited Nickel
ZN	Aluminum	Zinc-Nickel, Olive Drab
ZR	Aluminum	Zinc Nickel, Black - RoHS
H2*	Stainless Steel	Electro-Deposited Nickel

*Some dimensions do not apply. See drawing 240-838JH2

Table II: Capacitor Array Code Capacitance Range		
Class	Pi - Circuit (pF)	C - Circuit (pF)
X*	160,000 - 240,000	80,000 - 120,000
Y*	80,000 - 120,000	40,000 - 60,000
Z*	60,000 - 90,000	30,000 - 45,000
A	38,000 - 56,000	19,000 - 28,000
B	32,000 - 45,000	16,000 - 22,500
C	18,000 - 33,000	9,000 - 16,500
D	8,000 - 12,000	4,000 - 6,000
E	3,300 - 5,000	1,650 - 2,500
F	800 - 1,300	400 - 650
G	400 - 600	200 - 300
J	70-120	35-60

* Filter Classes X, Y and Z are 250 VDC.
All others are 500 VDC

Table III: Dimensions				
Shell Size	A Max	Ø B Max	C Thread -2A	E Thread -2A
8	.979 (24.9)	1.068 (27.1)	.625-20 UN	.500-20 UNF
10	1.104 (28.0)	1.192 (30.3)	.750-20 UNEF	.625-24 UNEF
12	1.291 (32.8)	1.380 (35.1)	.938-20 UNEF	.750-20 UNEF
14	1.391 (35.3)	1.505 (38.2)	1.000-20 UNEF	.875-20 UNEF
16	1.516 (38.5)	1.630 (41.4)	1.125-18 UNEF	1.000-20 UNEF
18	1.641 (41.7)	1.756 (44.6)	1.250-18 UNEF	1.062-18 UNEF
20	1.766 (44.9)	1.860 (47.2)	1.375-18 UNEF	1.188-18 UNEF
22	1.954 (49.6)	2.086 (52.6)	1.500-18 UNEF	1.312-18 UNEF
24	2.079 (52.8)	2.160 (54.9)	1.625-18 UNEF	1.438-18 UNEF

Dimensions in inches (millimeters) and are subject to change without notice.

MIL-DTL-83723 SERIES III WALL MOUNT RECEPTACLE, BAYONET COUPLING

How To Order										
Sample Part Number	240-838	W	ME	24-61	P	S	P	A	H	N
Filter Connector	MIL-DTL-83723 Series III Type, Bayonet Coupling									
Shell Style	W = Wall Mount									
Connector Class	See Table I									
Insert Arrangement	IAW MIL-STD-1554. (See pages B-72 – B-73)									
Contact Gender	P = Pin IAW D83723/72 S = Socket IAW D83723/71									
Termination	S = Solder Cup P = PC Tail, Straight T = PC Tail, with Shoulder									
Filter Type	P = Pi Circuit C = C Circuit (See Note 1)									
Capacitance	See Table II									
Flange Mounting Style	H = Round Holes C = Clinch Nuts (4-40 UNC) M = Metric Clinch Nuts (M3)									
Alternate Insert Position	IAW MIL-DTL-83723 and MIL-STD-1554 1, 2, 3, 4, 5, 6, 7, 8, 9, Y, N = Normal (See page B-73)									

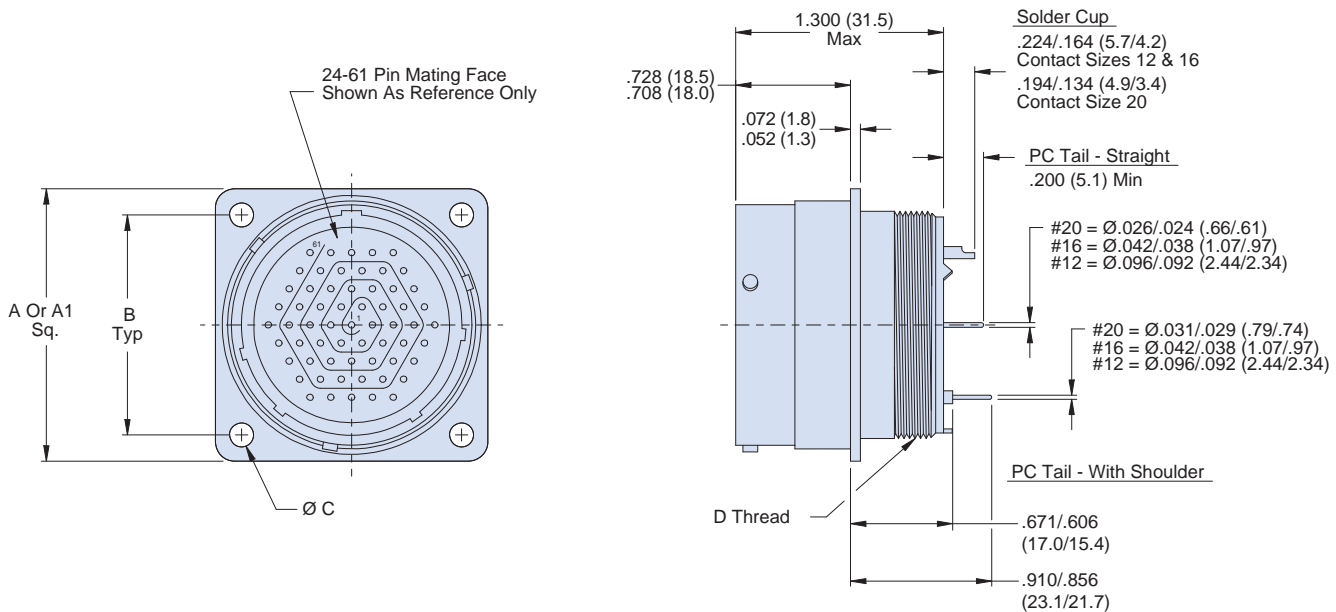
Notes

- Other filter styles (C-L, L-C, Unbalanced Pi, Multi-Stage, Multi-Value) are available, please consult the factory.

Dimensions in inches (millimeters) and are subject to change without notice.

240-838W
Glenair MIL-DTL-83723 Series III Type
Wall Mount Receptacle, Bayonet Coupling



MIL-DTL-83723
Type

B

Sym	Material	Finish Description
ME	Aluminum	Electroless Nickel
MT		Ni-PTFE 1000 Hour Grey™ Nickel Fluorocarbon Polymer
NF		Cadmium O.D. Over Electroless Nickel
ZL	Stainless Steel	Electro-Deposited Nickel
ZN	Aluminum	Zinc-Nickel, Olive Drab
ZR	Aluminum	Zinc Nickel, Black - RoHS
H2*	Stainless Steel	Electro-Deposited Nickel

*Some dimensions do not apply. See drawing 240-837WH2

Class	Pi - Circuit (pF)	C - Circuit (pF)
X*	160,000 - 240,000	80,000 - 120,000
Y*	80,000 - 120,000	40,000 - 60,000
Z*	60,000 - 90,000	30,000 - 45,000
A	38,000 - 56,000	19,000 - 28,000
B	32,000 - 45,000	16,000 - 22,500
C	18,000 - 33,000	9,000 - 16,500
D	8,000 - 12,000	4,000 - 6,000
E	3,300 - 5,000	1,650 - 2,500
F	800 - 1,300	400 - 650
G	400 - 600	200 - 300
J	70-120	35-60

* Filter Classes X, Y and Z are 250 VDC.
All others are 500 VDC

Shell Size	Thru Hole Flange		Clinch Nut Flange	B Typ	D Thread
	A Sq. Typ	Ø C	A1 Sq. ±.020 (.51)		
8	.812 (20.6)	.125 (3.2) .116 (2.9)	.895 (22.7)	.594 (15.1)	.5000-20 UNF-2A
10	.937 (23.8)	.125 (3.2) .116 (2.9)	1.019 (25.9)	.719 (18.3)	.6250-24 UNEF-2A
12	1.031 (26.2)	.125 (3.2) .116 (2.9)	1.112 (28.2)	.812 (20.6)	.7500-20 UNEF-2A
14	1.125 (28.6)	.125 (3.2) .116 (2.9)	1.206 (30.6)	.906 (23.0)	.8750-20 UNEF-2A
16	1.250 (31.8)	.125 (3.2) .116 (2.9)	1.269 (32.2)	.969 (24.6)	1.0000-20 UNEF-2A
18	1.343 (34.1)	.125 (3.2) .116 (2.9)	1.362 (34.6)	1.062 (27.0)	1.0625-18 UNEF-2A
20	1.437 (36.5)	.125 (3.2) .116 (2.9)	1.456 (37.0)	1.156 (29.4)	1.1875-18 UNEF-2A
22	1.562 (39.7)	.125 (3.2) .116 (2.9)	1.562 (39.7)	1.250 (31.8)	1.3125-18 UNEF-2A
24	1.703 (43.3)	.154 (3.9) .145 (3.7)	1.719 (43.7)	1.375 (34.9)	1.4375-18 UNEF-2A

Dimensions in inches (millimeters) and are subject to change without notice.



ITS Series, VG 95234 Type Reverse-Bayonet Filter Connectors

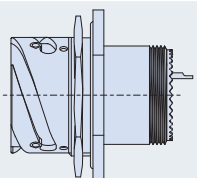

240-ITSJ

Jam Nut Receptacles

**Page
B-92**

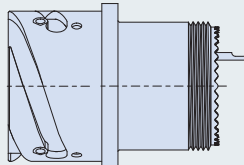

240-ITSW

Rear Panel Mount Receptacles

**Page
B-94**



- Fast, easy bayonet coupling connector: 1/4 turn
- Ideal for rail, industrial and military applications
- C filter circuits from 9,000 pF to 120,000 pF
- Low-pass multilayer ceramic planar array
- All shell styles: plug, square flange, jam-nut, etc.
- High shock and vibration resistance
- Contact sizes from #0 to #8 and #12 in limited insert arrangements
- Solder-cup terminations
- Intermateable with Veam CIR, Amphenol GT and ITT Cannon CA**B, and all VG 95234 reverse bayonet connectors

FILTERED HARSH-ENVIRONMENT SOLUTIONS FOR POPULAR ITS SERIES INDUSTRIAL, RAIL, AND MILITARY BAYONET CONNECTORS

The Glenair Series ITS Reverse Bayonet Power and Signal Connector is ideally suited for all rugged application connections. Based on the MIL-DTL-5015 standard and sharing many of the same insert arrangements and shell dimensions, the reverse bayonet provides faster coupling, especially when the connector is situated in an awkward or hard to reach location. The connector's high resistance to vibration and shock provides reliable mating in even the most rigorous application environments. Environmental protection to IP67 levels provides additional reliability.

Dimensions in inches (millimeters) and are subject to change without notice.

ITS Series, VG 95234 Type Reverse-Bayonet Filter Connectors Panel Cut-Outs



Notes

- Materials/Finishes: Shells, Jam Nut - See Table II
Insulators - high grade rigid dielectric/N.A.
Seals - Fluorosilicone
Contacts: Copper alloy 50μ" Gold over 50μ" Nickel
- Assembly to be identified with Glenair's name, part number, and date code - space permitting.
- Insert Arrangement in accordance with MIL-STD-1651. (Arrangement shown for reference only)
- EMI Circular Filters designed to meet requirements of MIL-STD-2120 and VG 95234.
- All contacts to have identical filter value. Other filter arrangements available, contact factory.
- Electrical Ratings: DWV- 500 VDC; Standard Operating Voltage 200 VDC.
- Insulation Resistance: 5000 MegOhms Min. at 200 VDC for Class A, B, C, D, E, F, G & J. 1,000 MegOhms @ 100 VDC for Classes X, Y, & Z
- Operating Temperature -55°C to +125°C (Env Class Connectors)
- Other filter styles (Pi, C-L, L-C, Unbalanced Pi, Multi-Stage, Multi-Value) are available, please consult the factory.

ITS Series Reverse Bayonet Rear Panel Mount Cut-Outs			
Shell Size	Ø A Min	B ±.004 (.1)	Ø C Holes
10SL	.752 (19.1)	.717 (18.2)	.182 (4.6) .172 (4.4)
14S	1.004 (25.5)	.906 (23.0)	
16, 16S	1.114 (28.3)	.969 (24.6)	
18	1.248 (31.7)	1.062 (27.0)	
20	1.378 (35.0)	1.157 (29.4)	
22	1.508 (38.3)	1.252 (31.8)	
24	1.646 (41.8)	1.374 (34.9)	
28	1.874 (47.6)	1.563 (39.7)	.222 (5.6) .212 (5.4)
32	2.138 (54.3)	1.752 (44.5)	
36	2.382 (60.5)	1.937 (49.2)	
40	2.614 (66.4)	2.185 (55.5)	

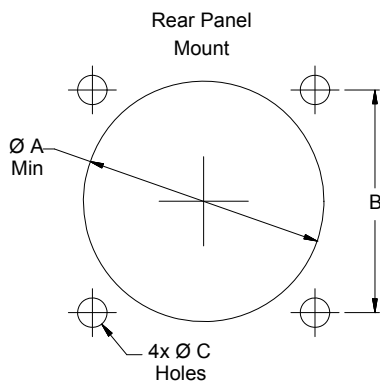

ITS Series Reverse Bayonet Jam Nut Mount Cut-Outs		
Shell Size	ø D	E Flat
10SL	.892 (22.66)	.827 (21.00)
	.882 (22.40)	.813 (20.65)
14S	1.142 (29.01)	1.079 (27.40)
	1.132 (28.75)	1.065 (27.05)
16, 16S	1.268 (32.21)	1.219 (30.95)
	1.258 (31.95)	1.205 (30.61)
18	1.392 (35.36)	1.329 (33.75)
	1.382 (35.10)	1.315 (33.40)
20	1.518 (38.56)	1.451 (36.85)
	1.508 (38.30)	1.437 (36.50)
22	1.642 (41.71)	1.577 (40.05)
	1.632 (41.45)	1.563 (39.70)
24	1.768 (44.91)	1.707 (43.35)
	1.758 (44.65)	1.693 (43.00)
28	2.018 (51.26)	1.951 (49.55)
	2.008 (51.00)	1.937 (49.20)
32	2.268 (57.61)	2.203 (55.95)
	2.258 (57.35)	2.189 (55.60)
36	2.518 (63.96)	2.455 (62.35)
	2.508 (63.70)	2.441 (62.00)
40	2.768 (70.31)	2.699 (68.55)
	2.758 (70.05)	2.685 (68.20)

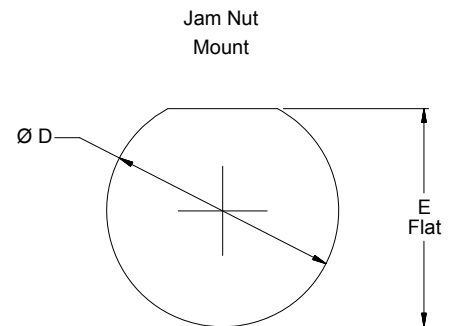

Dimensions in inches (millimeters) and are subject to change without notice.



ITS Series, VG 95234 Insert Arrangements and Insert Positions for Filter Connectors

B

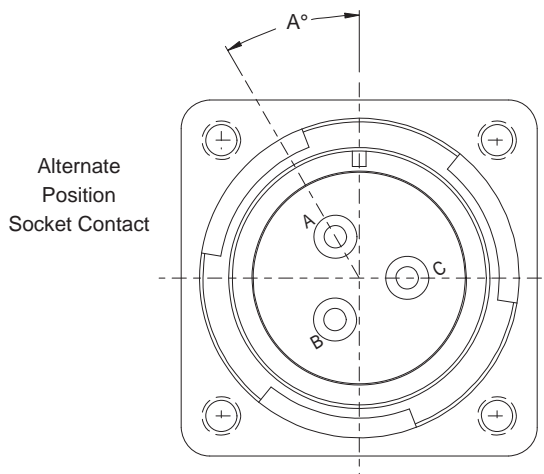
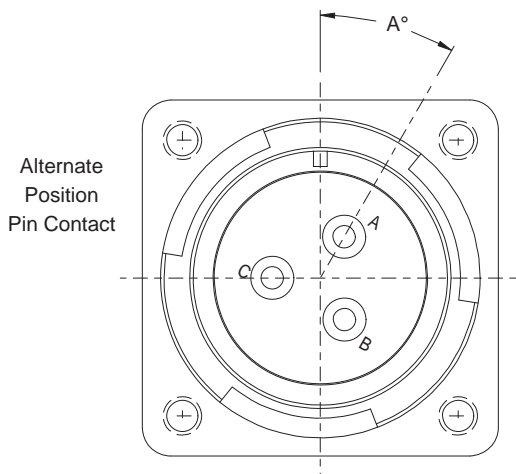

ITS Series Insert Arrangements and Insert Positions							
Insert Arrg.	Contacts		A° Insert Positions				
	Qty	Size	N°	W°	X°	Y°	Z°
10SL-3	3	16	0°	-	-	-	-
10SL-4	2	16	0°	-	-	-	-
14S-1	3	16	0°	90°	180°	270°	-
14S-2	4	16	0°	-	120°	240°	-
14S-5	5	16	0°	-	110°	-	-
14S-6	6	16	0°	90°	-	-	-
14S-7	3	16	0°	90°	180°	270°	-
14S-9	2	16	0°	70°	145°	215°	290°
16S-1	7	16	0°	80°	-	-	280°
16S-4	2	16	0°	35°	110°	250°	325°
16S-5	3	16	0°	70°	145°	215°	290°
16S-8	5	16	0°	-	170°	265°	-
16-2	1	12	0°	-	-	-	-
16-7	2	16	0°	80°	110°	250°	280°
	1	8					
16-9	2	16	0°	35°	110°	250°	325°
	2	12					
16-10	3	12	0°	90°	180°	270°	-
16-11	2	12	0°	35°	110°	250°	325°
16-12	1	4	0°	-	-	-	-
16A-10	10	18	0°	35°	112°	235°	315°
18-1	10	16	0°	70°	145°	215°	290°
18-3	2	12	0°	35°	110°	250°	325°
18-4	4	16	0°	35°	110°	250°	325°
18-5	1	16	0°	80°	110°	250°	280°
	2	12					
18-06	2	16	0°	-	-	-	-
	4	12					
18-6	1	4	0°	-	-	-	-

ITS Series Insert Arrangements and Insert Positions							
Insert Arrg.	Contacts		A° Insert Positions				
	Qty	Size	N°	W°	X°	Y°	Z°
18-7	1	8	0°	-	-	-	-
18-8	7	16	0°	70°	-	-	290°
	1	12					
18-9	5	16	0°	80°	110°	250°	280°
	2	12					
18-10	4	12	0°	-	120°	240°	-
18-11	5	12	0°	-	170°	265°	-
18-12	6	16	0°	80°	-	-	280°
18-13	3	12	0°	80°	110°	250°	280°
	1	8					
18-14	1	16	0°	80°	110°	250°	280°
	1	4					
18-16	1	12	0°	-	-	-	-
18-19	10	16	0°	-	120°	240°	-
18-20	5	16	0°	90°	180°	270°	-
18-22	3	16	0°	70°	145°	215°	290°
20-3	3	12	0°	70°	145°	215°	290°
20-4	4	12	0°	45°	110°	250°	-
20-6	3	16	0°	70°	145°	215°	290°
20-7	8	16	0°	80°	110°	250°	280°
20-8	4	16	0°	80°	110°	250°	280°
	2	8					
20-9	7	16	0°	80°	110°	250°	280°
	1	12					
20-11	13	16	0°	-	-	-	-
20-14	3	12	0°	80°	110°	250°	280°
	2	8					
20-15	7	12	0°	80°	-	-	280°

Dimensions in inches (millimeters) and are subject to change without notice.

ITS Series, VG 95234 Insert Arrangements and Insert Positions for Filter Connectors



ITS Series Insert Arrangements and Insert Positions							
Insert Arrg.	Contacts		A° Insert Positions				
	Qty	Size	N°	W°	X°	Y°	Z°
20-16	7	16	0°	80°	110°	250°	280°
	2	12					
20-17	1	16	0°	90°	180°	270°	-
	5	12					
20-18	6	16	0°	35°	110°	250°	325°
	3	12					
20-19	3	8	0°	90°	180°	270°	-
20-21	8	16	0°	35°	110°	250°	325°
	1	12					
20-22	3	16	0°	80°	110°	250°	280°
	3	8					
20-23	2	8	0°	35°	110°	250°	325°
20-24	2	16	0°	35°	110°	250°	325°
	2	8					
20-27	14	16	0°	35°	110°	250°	325°
20-29	17	16	0°	80°	-	-	280°
20A-8	6	16	0°	35°	110°	250°	325°
	2	8					
20A-9	9	12	0°	-	110°	250°	-
20A-29	25	18	0°	45°	-	210°	-
	4	12					
20A-48	19	16	0°	-	80°	280°	-
22-1	2	8	0°	35°	110°	250°	325°
22-2	3	8	0°	70°	145°	215°	290°
22-4	2	12	0°	35°	110°	250°	325°
	2	8					
22-5	4	16	0°	35°	110°	250°	325°
	2	12					
22-6	1	16	0°	80°	110°	250°	280°
	2	8					
22-8	2	12	0°	35°	110°	250°	325°
22-9	3	12	0°	70°	145°	215°	290°
22-10	4	16	0°	35°	110°	250°	325°
22-11	2	16	0°	35°	110°	250°	325°
22-12	3	16	0°	80°	110°	250°	280°
	2	8					
22-14	19	16	0°	80°	-	-	280°
22-15	1	16	0°	80°	110°	250°	280°
	5	12					
22-16	6	16	0°	80°	110°	250°	280°
	3	12					
22-17	8	16	0°	80°	110°	250°	280°
	1	12					
22-18	8	16	0°	80°	110°	250°	280°
22-19	14	16	0°	80°	110°	250°	280°
22-20	9	16	0°	35°	110°	250°	325°
22-22	4	8	0°	-	110°	250°	-

ITS Series Insert Arrangements and Insert Positions							
Insert Arrg.	Contacts		A° Insert Positions				
	Qty	Size	N°	W°	X°	Y°	Z°
22-23	8	12	0°	35°	-	250°	-
22-27	8	16	0°	80°	-	250°	280°
	1	8					
22-28	7	12	0°	80°	-	-	280°
22-34	2	16	0°	80°	110°	250°	280°
	3	12					
22A-9	9	16	0°	60°	135°	250°	305°
22A-10	10	16	0°	-	120°	240°	-
22A-37	37	18	0°	80°	112°	250°	280°
24-2	7	12	0°	80°	-	-	280°
24-3	5	16	0°	80°	110°	250°	280°
	2	12					
24-5	16	16	0°	80°	110°	250°	280°
24-06	2	16	0°	-	-	-	-
	4	8					
24-6	8	12	0°	80°	110°	250°	280°
24-07	7	12	0°	80°	-	-	280°
24-7	14	16	0°	80°	110°	250°	280°
	2	12					
24-9	2	4	0°	35°	110°	250°	325°
24-10	7	8	0°	80°	-	-	280°
24-11	6	12	0°	35°	110°	250°	325°
	3	8					
24-12	3	12	0°	80°	110°	250°	280°
	2	4					
24-013	7	16	0°	-	-	-	-
	6	12					
24-19	12	16	0°	-	-	-	-
24-20	9	16	0°	80°	110°	250°	280°
	2	12					
24-21	9	16	0°	80°	110°	250°	280°
	1	8					
24-22	4	8	0°	45°	110°	250°	-
24-27	7	16	0°	80°	-	-	280°
24-28	24	16	0°	80°	110°	250°	280°
24-67	19	12	0°	80°	-	-	335°
24A-2	2	12	0°	35°	110°	250°	325°
24A-6	4	12	0°	42°	134°	262°	339°
	2	8					
24A-7	7	12	0°	80°	-	-	280°
24A-11	9	16	0°	35°	110°	250°	325°
	2	8					
24A-25	25	16	0°	80°	110°	250°	280°
24A-28	28	16	0°	65°	146°	235°	-
24A-55	55	18	0°	80°	110°	250°	280°
28-1	6	12	0°	80°	110°	250°	280°
	3	8					

Dimensions in inches (millimeters) and are subject to change without notice.



ITS Series, VG 95234 Insert Arrangements and Insert Positions for Filter Connectors

B

ITS Series Insert Arrangements and Insert Positions							
Insert Arrg.	Contacts		A° Insert Positions				
	Qty	Size	N°	W°	X°	Y°	Z°
28-2	12	16	0°	35°	110°	250°	325°
	2	12					
28-3	3	8	0°	70°	145°	215°	290°
28-5	2	16	0°	35°	110°	250°	325°
	1	12					
	2	4					
28-6	3	4	0°	70°	145°	215°	290°
28-9	6	16	0°	80°	110°	250°	280°
	6	12					
28-10	3	12	0°	80°	110°	250°	280°
	2	8					
	2	4					
28-11	18	16	0°	80°	110°	250°	280°
	4	12					
28-12	26	16	0°	90°	180°	270°	-
28-15	35	16	0°	80°	110°	250°	280°
28-16	20	16	0°	80°	110°	250°	280°
28-17	15	16	0°	80°	110°	250°	280°
28-18	12	16	0°	70°	145°	215°	390°
28-19	6	16	0°	80°	110°	250°	280°
	4	12					
28-20	4	16	0°	80°	110°	250°	280°
	10	12					
28-21	37	16	0°	80°	110°	250°	280°
28-22	3	16	0°	70°	145°	215°	290°
	3	4					
28-59	10	16	0°	35°	110°	250°	325°
	7	12					
28A-9	5	16	0°	110°	250°	260°	280°
	4	4					
28A-10	10	12	0°	80°	135°	195°	-
28A-14	14	12	0°	35°	90°	-	-
28A-31	13	16	0°	35°	-	260°	210°
	18	12					
32-1	3	12	0°	80°	110°	250°	280°
	2	0					
32-2	2	16	0°	70°	145°	215°	290°
	3	4					
32-3	4	16	0°	80°	110°	250°	280°
	2	12					
	2	4					
	1	0					
32-5	2	0	0°	35°	110°	250°	325°
32-6	16	16	0°	80°	110°	250°	280°
	2	12					
	3	8					
	2	4					

ITS Series Insert Arrangements and Insert Positions							
Insert Arrg.	Contacts		A° Insert Positions				
	Qty	Size	N°	W°	X°	Y°	Z°
32-7	28	16	0°	80°	125°	235°	280°
	12	12					
32-8	24	16	0°	80°	125°	235°	280°
	6	12					
32-9	12	16	0°	80°	110°	250°	280°
	2	4					
32-013	13	12	0°	65°	130°	230°	295°
32-13	18	16	0°	80°	110°	250°	280°
	5	12					
32-15	16	16	0°	35°	110°	250°	280°
	16	16					
32-17	4	4	0°	45°	110°	250°	-
32-22	54	16	0°	80°	110°	250°	280°
32-31	31	16	0°	-	125°	215°	280°
32-59	40	16	0°	36°	108°	252°	324°
	2	8					
32-68	12	16	0°	65°	135°	225°	275°
	4	4					
32-76	19	12	0°	80°	110°	250°	280°
32-101	101	20	0°	30°	142°	-	-
32A-3	3	4	0°	22°	44°	75°	98°
32A-5	5	4	0°	90°	180°	270°	-
32A-8	8	8	0°	35°	122°	-	315°
32A-13	13	12	0°	65°	130°	230°	295°
32A-14	14	16	0°	35°	90°	-	-
32A-22	20	16	0°	55°	135°	230°	295°
	2	0					
32A-25	25	12	0°	60°	120°	-	-
32A-27	17	16	0°	30°	115°	285°	335°
	10	8					
32A-30	20	16	0°	65°	-	-	-
	10	8					
32A-40	40	16	0°	35°	130°	-	-
32A-48	48	16	0°	80°	125°	235°	280°
32A-55	55	16	0°	80°	110°	250°	280°
32A-69	41	20	0°	-	110°	250°	-
	20	16					
36-3	3	12	0°	70°	145°	215°	290°
	3	0					
36-4	3	0	0°	70°	145°	215°	290°
36-5	4	0	0°	45°	120°	240°	-
	4	4					
36-6	2	0	0°	-	110°	250°	325°
	4	4					
36-7	40	16	0°	80°	110°	250°	280°
	7	12					

Dimensions in inches (millimeters) and are subject to change without notice.

ITS Series, VG 95234 Insert Arrangements and Insert Positions for Filter Connectors



Series ITS
VG 95234 Type

B

ITS Series Insert Arrangements and Insert Positions							
Insert Arrg.	Contacts		A° Insert Positions				
	Qty	Size	N°	W°	X°	Y°	Z°
36-8	46	16	0°	80°	110°	250°	280°
	1	12					
36-9	14	16	0°	80°	125°	235°	280°
	14	12					
	2	8					
	1	4					
36-10	48	16	0°	80°	110°	235°	280°
36-14	6	16	0°	90°	180°	270°	-
	5	12					
	5	8					
36-15	35	16	0°	60°	125°	245°	305°
36-22	22	12	0°	70°	145°	215°	290°
36A-2	2	0	0°	70°	145°	215°	290°
36A-10	8	8	0°	70°	145°	215°	290°
	2	4					
36A-22	22	12	0°	80°	110°	250°	280°
36A-48	48	16	0°	65°	-	-	-
36A-51	1	16	0°	45°	135°	225°	315°
	2	4					
	3	0					
36A-61	4	12	0°	80°	-	-	280°
	2	4					
36A-72	52	18	0°	-	110°	-	-
	16	16					
	4	12					
36B-78	2	16	0°	35°	106°	254°	325°
	12	8					
36D-78	4	16	0°	35°	106°	254°	325°
	10	8					
40-1	24	16	0°	65°	130°	235°	300°
	6	12					
40-9	24	16	0°	65°	125°	225°	310°
	22	12					
	1	8					
40-10	16	16	0°	65°	125°	225°	310°
	9	8					
	4	4					
40-26	19	12	0°	80°	110°	250°	280°
	7	8					
40-31	31	12	0°	80°	110°	250°	280°
40-35	35	12	0°	70°	130°	230°	290°
40-47	24	16	0°	65°	125°	225°	310°
	22	12					
	1	8					
	1	8					
40-53	60	16	0°	80°			280°
40-56	85	16	0°	72°	144°	216°	288°
40-63	61	16	0°	80°	-	-	280°

ITS Series Insert Arrangements and Insert Positions							
Insert Arrg.	Contacts		A° Insert Positions				
	Qty	Size	N°	W°	X°	Y°	Z°
40-150	150	18	0°	-	-	-	-
	26	16	0°	-	-	-	-
25	12						
40A-3	2	12	0°	50°	145°	215°	290°
	3	0					
40A-4	2	12	0°	33°	120°	240°	325°
	4	0					
40A-5	1	12	0°	108°	-	-	270°
	1	4					
	3	0					
40A-7	2	12	0°	35°	-	-	-
	5	0					
40A-8	4	16	0°	80°	110°	250°	325°
	4	0					
40A-10	4	16	0°	-	-	-	-
	4	4					
40A-14	6	12	0°	80°	135°	195°	-
	8	4					
40A-20	18	12	0°	50°	110°	250°	280°
	2	8					
40A-21	20	12	0°	50°	130°	260°	280°
	1	4					
40A-24	16	12	0°	27°	-	-	-
	8	8					
40A-25	24	12	0°	50°	130°	260°	280°
	1	4					
40A-27	25	12	0°	45°	110°	250°	315°
	2	4					
40A-30	29	12	0°	30°	-	-	295°
	1	4					
40A-31	31	12	0°	80°	110°	250°	280°
40A-35	35	12	0°	70°	130°	230°	290°
40A-47	24	16	0°	65°	125°	225°	310°
	22	12					
	1	8					
40A-56	85	16	0°	72°	144°	216°	288°
40A-60	60	16	0°	80°	110°	250°	280°
40A-62	60	16	0°	80°	130°	230°	280°
	2	8					
40A-100	100	18	0°	30°	105°	230°	315°
40A-130	114	18	0°	45°	113°	-	309°
	12	16					
	4	12					
40B-19	19	8	0°	35°	105°	225°	325°
40B-37	37	12	0°	30°	135°	-	-
40D-4	4	8	0°	45°	110°	-	-
40D-37	37	12	0°	80°	110°	250°	280°

Dimensions in inches (millimeters) and are subject to change without notice.

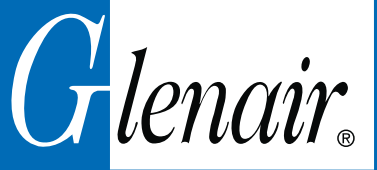

240-ITSJ
VG 95234 Type Receptacle Connector
Jam Nut Mount with Reverse Bayonet Coupling

VG 95234 TYPE JAM NUT RECEPTACLE, REVERSE BAYONET COUPLING

B

How To Order	
Sample Part Number	240-ITS J NF 20-3 P S C B N
Filter Connector	VG 95234 Type
Shell Style	J = Jam Nut JT = Jam Nut with Accessory Thread (See Note 2)
Connector Class	See Table II
Insert Arrangement	See pages B-88 – B-91
Contact Gender	P = Pin S = Socket
Termination Type	S = Solder Cup
Filter Type	C = C Circuit (See Note 1)
Capacitance	See Table III
Alternate Insert Position	W, X, Y, Z, N = Normal (See pages B-88 – B-91)

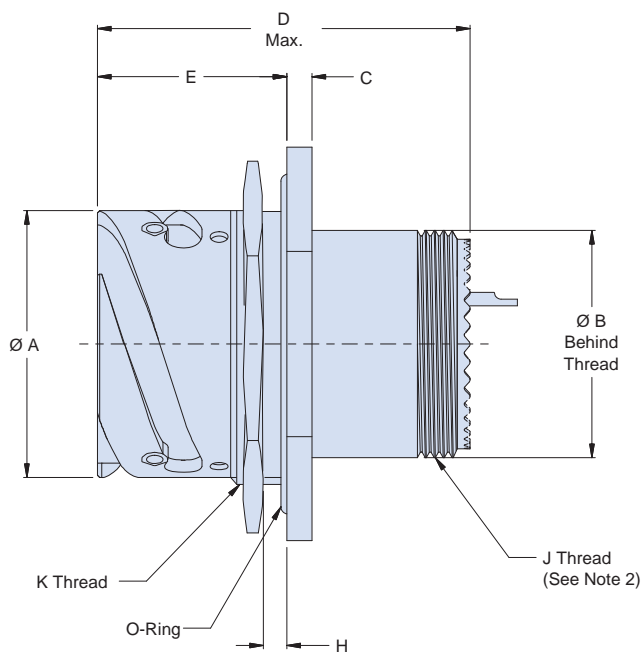
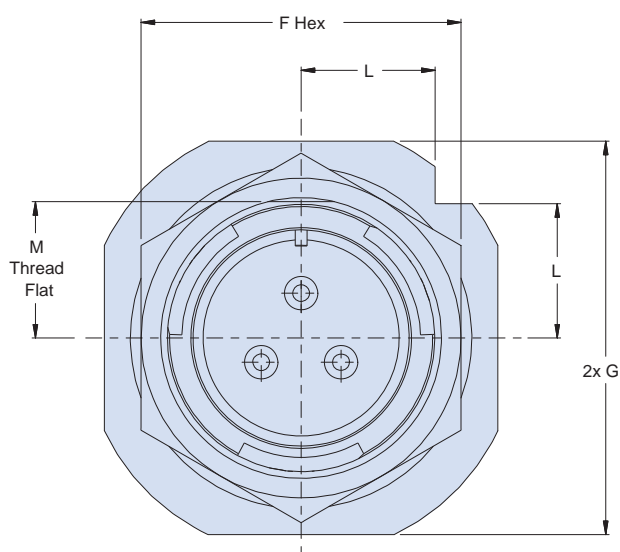

Notes

- Other filter styles (Pi, C-L, L-C, Unbalanced Pi, Multi-Stage, Multi-Value) are available, please consult the factory.
- Shell style JT shown. Shell style J is less accessory threads and teeth.

Dimensions in inches (millimeters) and are subject to change without notice.

240-ITSJ
VG 95234 Type Receptacle Connector
Jam Nut Mount with Reverse Bayonet Coupling



Series ITS
 VG 95234 Type

B

Table I: Dimensions

Shell Size	Ø A +.000 (.00) -.006 (.15)	Ø B Max	C ±.008 (±.20)	D Max	E ±.008 (±.20)	F Hex ±.016 (±.40)	G ±.008 (±.20)	H Panel	J Thread 2A	K Thread 2A	L	M Flat
10SL	.717 (18.2)	.638 (16.2)	.157 (3.99)	1.650 (41.9)	.965 (24.5)	1.063 (27.0)	1.252 (31.8)	.205 (5.2) .094 (2.4)	.625-24 UNEF	.875-20 UNEF	.441 (11.2)	.366 (9.3) .362 (9.2)
14S	.969 (24.6)	.756 (19.2)	.189 (4.80)	1.650 (41.9)	1.055 (26.8)	1.300 (33.0)	1.626 (41.3)	.295 (7.5) .094 (2.4)	.750-20 UNEF	1.125-18 UNEF	.575 (14.6)	.520 (13.2) .516 (13.1)
16S	1.079 (27.4)	.882 (22.4)	.189 (4.80)	1.650 (41.9)	1.055 (26.8)	1.496 (38.0)	1.748 (44.4)	.295 (7.5) .094 (2.4)	.875-20 UNEF	1.250-18 UNEF	.618 (15.7)	.587 (14.9) .583 (14.8)
16	1.079 (27.4)	.882 (22.4)	.189 (4.80)	1.800 (45.7)	1.268 (32.2)	1.496 (38.0)	1.748 (44.4)	.295 (7.5) .094 (2.4)	.875-20 UNEF	1.250-18 UNEF	.618 (15.7)	.587 (14.9) .583 (14.8)
18	1.213 (30.8)	1.008 (25.6)	.189 (4.80)	1.800 (45.7)	1.327 (33.7)	1.555 (39.5)	1.874 (47.6)	.354 (9.0) .094 (2.4)	1.000-20 UNEF	1.375-18 UNEF	.661 (16.8)	.622 (15.8) .618 (15.7)
20	1.346 (34.2)	1.142 (29.0)	.189 (4.80)	1.800 (45.7)	1.327 (33.7)	1.732 (44.0)	2.000 (50.8)	.354 (9.0) .094 (2.4)	1.125-18 UNEF	1.500-18 UNEF	.709 (18.0)	.689 (17.5) .685 (17.4)
22	1.472 (37.4)	1.268 (32.2)	.189 (4.80)	1.800 (45.7)	1.327 (33.7)	1.803 (45.8)	2.134 (54.2)	.358 (9.1) .094 (2.4)	1.250-18 UNEF	1.625-18 UNEF	.795 (20.2)	.740 (18.8) .736 (18.7)
24	1.610 (40.9)	1.390 (35.3)	.189 (4.80)	1.800 (45.7)	1.327 (33.7)	2.000 (50.8)	2.252 (57.2)	.358 (9.1) .094 (2.4)	1.375-18 UNEF	1.750-18 UNS	.795 (20.2)	.815 (20.7) .811 (20.6)
28	1.839 (46.7)	1.630 (41.4)	.220 (5.59)	1.800 (45.7)	1.386 (35.2)	2.157 (54.8)	2.500 (63.5)	.335 (8.5) .094 (2.4)	1.625-18 UNEF	2.000-18 UNS	.886 (22.5)	.933 (23.7) .929 (23.6)
32	2.102 (53.4)	1.882 (47.8)	.220 (5.59)	1.800 (45.7)	1.386 (35.2)	2.441 (32.0)	2.748 (69.8)	.256 (6.5) .094 (2.4)	1.875-16 UN	2.250-16 UN	.972 (24.7)	1.051 (26.7) 1.047 (26.6)
36	2.346 (59.6)	2.130 (54.1)	.220 (5.59)	1.800 (45.7)	1.386 (35.2)	2.795 (71.0)	3.000 (76.2)	.327 (8.3) .094 (2.4)	2.0625-16 UN	2.500-16 UN	1.059 (26.9)	1.201 (30.5) 1.197 (30.4)
40	2.579 (65.5)	2.323 (59.0)	.220 (5.59)	1.800 (45.7)	1.386 (35.2)	2.953 (75.0)	3.287 (83.5)	.327 (8.3) .094 (2.4)	2.3125-16 UN	2.750-16 UN	1.165 (29.6)	1.319 (33.5) 1.315 (33.4)

Table II: Connector Class

Sym	Material	Finish Description
ME	Aluminum	Electroless Nickel
NF		Cadmium O.D. Over Electroless Nickel
ZL	Stainless Steel	Electro-Deposited Nickel

**Table III: Capacitor Array Code
 Capacitance Range**

Class	C - Circuit (pF)
X	80,000 - 120,000
Y	40,000 - 60,000
Z	30,000 - 45,000
A	19,000 - 28,000
B	16,000 - 22,500
C	9,000 - 16,500

Dimensions in inches (millimeters) and are subject to change without notice.

240-ITSW
VG 95234 Type Receptacle Connector
Rear Panel Mount with Reverse Bayonet Coupling



Series ITS
VG 95234 Type

B

Table I: Dimensions

Shell Size	Ø A +.000 (.00) -.006 (.15)	Ø B Max	C ±.008 (±.20)	D Max	E +.016 (4.0) -.000 (0.0) (±.20)	F Bsc	G ±.012 (±.30)	H Thread	J Thread 2A
10SL	.717 (18.2)	.638 (16.2)	.110 (2.8)	1.650 (41.9)	.717 (18.2)	.719 (18.3)	1.000 (25.4)	M4	.625-24 UNEF
14S	.969 (24.6)	.756 (19.2)	.126 (3.2)	1.650 (41.9)	.717 (18.2)	.906 (23.0)	1.181 (30.0)	M4	.750-20 UNEF
16S	1.079 (27.4)	.882 (22.4)	.126 (3.2)	1.650 (41.9)	.717 (18.2)	.969 (24.6)	1.280 (32.5)	M4	.875-20 UNEF
16	1.079 (27.4)	.882 (22.4)	.126 (3.2)	1.800 (45.7)	.907 (23.0)	.969 (24.6)	1.280 (32.5)	M4	.875-20 UNEF
18	1.213 (30.8)	1.008 (25.6)	.157 (4.0)	1.800 (45.7)	.907 (23.0)	1.063 (27.0)	1.378 (35.0)	M4	1.000-20 UNEF
20	1.346 (34.2)	1.142 (29.0)	.157 (4.0)	1.800 (45.7)	.907 (23.0)	1.157 (29.4)	1.496 (38.0)	M4	1.125-18 UNEF
22	1.472 (37.4)	1.268 (32.2)	.157 (4.0)	1.800 (45.7)	.907 (23.0)	1.250 (31.8)	1.614 (41.0)	M4	1.250-18 UNEF
24	1.610 (40.9)	1.390 (35.3)	.157 (4.0)	1.800 (45.7)	.907 (23.0)	1.375 (34.9)	1.752 (44.5)	M4	1.375-18 UNEF
28	1.839 (46.7)	1.630 (41.4)	.157 (4.0)	1.800 (45.7)	.947 (24.1)	1.563 (39.7)	2.000 (50.8)	M5	1.625-18 UNEF
32	2.102 (53.4)	1.882 (47.8)	.157 (4.0)	1.800 (45.7)	.947 (24.1)	1.750 (44.5)	2.244 (57.0)	M5	1.875-16 UN
36	2.346 (59.6)	2.130 (54.1)	.157 (4.0)	1.800 (45.7)	.947 (24.1)	1.937 (49.2)	2.500 (63.5)	M5	2.0625-16 UN
40	2.579 (65.5)	2.323 (59.0)	.157 (4.0)	1.800 (45.7)	.947 (24.1)	2.187 (55.5)	2.752 (70.0)	M5	2.3125-16 UN

Table II: Connector Class

Sym	Material	Finish Description
ME	Aluminum	Electroless Nickel
NF		Cadmium O.D. Over Electroless Nickel
ZL	Stainless Steel	Electro-Deposited Nickel

**Table III: Capacitor Array Code
Capacitance Range**

Class	C - Circuit (pF)
X	80,000 - 120,000
Y	40,000 - 60,000
Z	30,000 - 45,000
A	19,000 - 28,000
B	16,000 - 22,500
C	9,000 - 16,500

Dimensions in inches (millimeters) and are subject to change without notice.

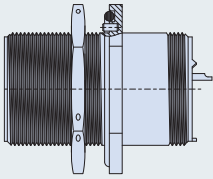
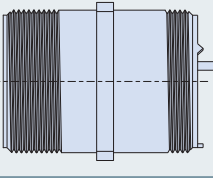
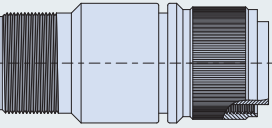
	240-515J	Jam Nut Receptacles MS3454	Page B-100
	240-515W	Wall Mount Receptacles MS3450	Page B-102
	240-515A	Connector Adapters	Page B-104

Notes

1. Materials/Finishes: Shells, Jam Nut, Coupling Nut - See Table II
Insulators - high grade rigid dielectric/N.A.
Seals - Fluorosilicone
Contacts: Copper alloy 50 μ " Gold over 50 μ " Nickel
2. Assembly to be identified with Glenair's name, part number, and date code - space permitting.
3. Insert Arrangement in accordance with MIL-STD-1651. (Arrangement shown for reference only)
4. EMI Circular Filter receptacle connectors designed to meet requirements of MIL-DTL-5015 Series III.
5. All contacts to have identical filter value. Other filter arrangements available, contact factory.
6. Electrical Ratings: DWV- 500 VDC; Standard Operating Voltage 200 VDC.
7. Insulation Resistance: 5000 MegOhms Min. at 200 VDC for classes A, B, C, and H.
1,000 MegOhms Min. at 100 VDC for classes X, Y, and Z
8. Operating Temperature -55°C to +125°C (Env Class Connectors)
9. Other filter styles (Pi, C-L, L-C, Unbalanced Pi, Multi-Stage, Multi-Value) are available, please consult the factory.

Dimensions in inches (millimeters) and are subject to change without notice.

MIL-DTL-5015 Series III Type Filter Connectors

Panel Cut-Outs and Insert Positions



MIL-DTL-5015
Type

B

MIL-DTL-5015 Series III Wall Mount Panel Cut-Outs				MIL-DTL-5015 Series III Jam Nut Panel Cut-Outs		
Shell Size	Ø A ±.010(.25)	B Typ	Ø C Holes	Ø D	E ±.005(.13)	
8S	.562 (14.3)	.594 (15.1)	.130 (3.3) .115 (2.9)	.520 (13.2) .505 (12.8)	.323 (8.2)	
10S, 10SL	.688 (17.5)	.719 (18.3)		.645 (16.4) .630 (16.0)	.385 (9.8)	
12, 12S	.812 (20.6)	.812 (20.6)		.770 (19.6) .755 (19.2)	.448 (11.4)	
14, 14S	.938 (23.8)	.906 (23.0)		.895 (22.7) .880 (22.4)	.510 (13.0)	
16, 16S	1.062 (27.0)	.969 (24.6)		1.020 (25.9) 1.005 (25.5)	.573 (14.6)	
18	1.188 (30.2)	1.062 (27.0)		1.145 (29.1) 1.130 (28.7)	.635 (16.1)	
20	1.312 (33.3)	1.156 (29.4)		1.270 (32.3) 1.255 (31.9)	.698 (17.7)	
22	1.438 (36.5)	1.250 (31.8)		1.395 (35.4) 1.380 (35.1)	.760 (19.3)	
24	1.562 (39.7)	1.375 (34.9)		.157 (4.0) .142 (3.6)	1.520 (38.6) 1.505 (38.2)	.823 (20.9)
28	1.812 (46.0)	1.562 (39.7)			1.770 (45.0) 1.755 (44.6)	.948 (24.1)
32	2.062 (52.4)	1.750 (44.5)	.183 (4.6) .168 (4.3)	2.020 (51.3) 2.005 (50.9)	1.073 (27.3)	
36	2.312 (58.7)	1.938 (49.2)		2.270 (57.7) 2.255 (57.3)	1.198 (30.4)	
40	2.562 (65.1)	2.188 (55.6)		2.520 (64.0) 2.505 (63.6)	1.323 (33.6)	

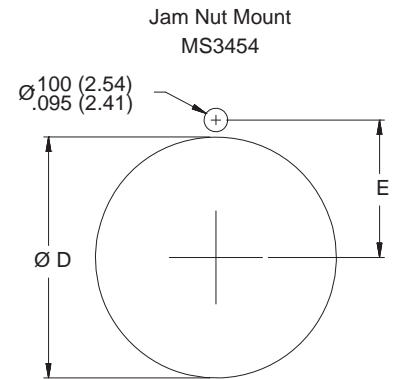
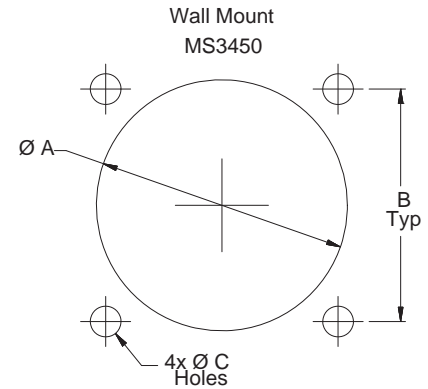

MIL-STD-1651 Insert Arrangements and Insert Positions							
Insert Arrg.	Contacts		A° Insert Positions				
	Qty	Size	N°	W°	X°	Y°	Z°
8S-1	1	16	0°	-	-	-	-
10S-2	1	16	0°	-	-	-	-
10SL-3	3	16	0°	-	-	-	-
10SL-4	2	16	0°	-	-	-	-
12-5	1	12	0°	-	-	-	-
12S-3	2	16	0°	70°	145°	215°	290°
12S-4	1	16	0°	-	-	-	-
14-3	1	8	0°	-	-	-	-
14S-2	4	16	0°	-	120°	240°	-
14S-5	5	16	0°	-	110°	-	-
14S-6	6	16	0°	-	-	-	-
14S-7	3	16	0°	90°	180°	270°	-
16-2	1	12	0°	-	-	-	-
16-7	2	16	0°	80°	110°	250°	280°
16-9	2	16	0°	35°	110°	250°	325°
	2	12					

MIL-STD-1651 Insert Arrangements and Insert Positions							
Insert Arrg.	Contacts		A° Insert Positions				
	Qty	Size	N°	W°	X°	Y°	Z°
16-10	3	12	0°	90°	180°	270°	-
16-11	2	12	0°	35°	110°	250°	325°
16-12	1	4	0°	-	-	-	-
16S-1	7	16	0°	80°	-	-	280°
16S-3	1	16	0°	-	-	-	-
16S-4	2	16	0°	35°	110°	250°	325°
16S-8	5	16	0°	-	170°	265°	-

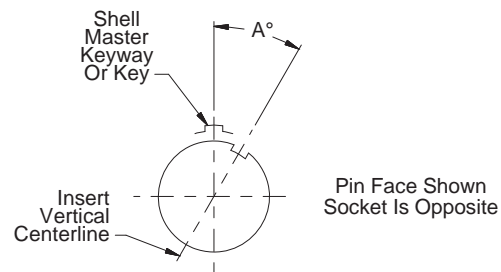

Dimensions in inches (millimeters) and are subject to change without notice.

© 2013 Glenair, Inc.

U.S. CAGE Code 06324

Printed in U.S.A.

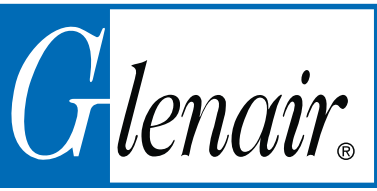

MIL-STD-1651 Insert Arrangements and Insert Positions for MIL-DTL-5015 Series III Type Filter Connectors

B

MIL-STD-1651 Insert Arrangements and Insert Positions							
Insert Arrg.	Contacts		A° Insert Positions				
	Qty	Size	N°	W°	X°	Y°	Z°
18-1	10	16	0°	70°	145°	215°	290°
18-4	4	16	0°	35°	110°	250°	325°
18-5	1	16	0°	80°	110°	250°	280°
	2	12					
18-6	1	4	0°	-	-	-	-
18-7	1	8	0°	-	-	-	-
18-8	7	16	0°	70°	-	-	290°
	1	12					
18-9	5	16	0°	80°	110°	250°	280°
	2	12					
18-11	5	12	0°	-	170°	265°	-
18-12	6	16	0°	80°	-	-	280°
20-2	1	0	0°	-	-	-	-
20-4	4	12	0°	45°	110°	250°	-
20-7	8	16	0°	80°	110°	250°	280°
20-8	4	16	0°	80°	110°	250°	280°
	2	8					
20-9	7	16	0°	80°	110°	250°	280°
	1	12					
20-14	3	12	0°	80°	110°	250°	280°
	2	8					
20-15	7	12	0°	80°	-	-	280°
20-16	7	16	0°	80°	110°	250°	280°
	2	12					
20-17	1	16	0°	90°	180°	270°	-
	5	12					
20-18	6	16	0°	35°	110°	250°	325°
	3	12					
20-21	8	16	0°	35°	110°	250°	325°
	1	12					
20-22	3	16	0°	80°	110°	250°	280°
	3	8					
20-27	14	16	0°	35°	110°	250°	325°
20-29	17	16	0°	80°	-	-	280°
20-33	11	16	0°	-	-	-	-
22-2	3	8	0°	70°	145°	215°	290°
22-5	4	16	0°	35°	110°	250°	325°
	2	12					
22-7	1	0	0°	-	-	-	-
22-9	3	12	0°	70°	145°	215°	290°
22-10	4	16	0°	35°	110°	250°	325°
22-11	2	16	0°	35°	110°	250°	325°
22-12	3	16	0°	80°	110°	250°	280°
	2	8					
22-13	1	16	0°	35°	110°	250°	325°
	4	12					
22-14	19	16	0°	80°	110°	250°	280°

MIL-STD-1651 Insert Arrangements and Insert Positions							
Insert Arrg.	Contacts		A° Insert Positions				
	Qty	Size	N°	W°	X°	Y°	Z°
22-15	1	16	0°	80°	110°	250°	280°
	5	12					
22-17	8	16	0°	80°	110°	250°	280°
	1	12					
22-18	8	16	0°	80°	110°	250°	280°
22-19	14	16	0°	80°	110°	250°	280°
22-21	2	16	0°	80°	110°	250°	280°
	1	0					
22-22	4	8	0°	-	110°	250°	-
22-23	8	12	0°	35°	-	250°	-
22-27	1	8	0°	80°	-	250°	280°
	8	16					
24-2	7	12	0°	80°	-	-	280°
24-4	3	16	0°	80°	110°	250°	280°
	1	0					
24-6	8	12	0°	80°	110°	250°	280°
24-7	14	16	0°	80°	110°	250°	280°
	2	12					
24-9	2	4	0°	35°	110°	250°	325°
24-10	7	8	0°	80°	-	-	280°
24-11	6	12	0°	35°	110°	250°	325°
	3	8					
24-12	3	12	0°	80°	110°	250°	280°
	2	4					
24-16	3	16	0°	80°	110°	250°	280°
	3	12					
	1	8					
24-20	9	16	0°	80°	110°	250°	280°
	2	12					
24-21	9	16	0°	80°	110°	250°	280°
	1	8					
24-22	4	8	0°	45°	110°	250°	-
24-27	7	16	0°	80°	-	-	280°
24-28	24	16	0°	80°	110°	250°	280°
28-1	6	12	0°	80°	110°	250°	280°
	3	8					
28-2	12	16	0°	35°	110°	250°	325°
	2	12					
28-3	3	8	0°	70°	145°	215°	290°
28-4	7	16	0°	80°	110°	250°	280°
	2	12					
28-5	2	16	0°	35°	110°	250°	325°
	1	12					
	2	4					
28-8	10	16	0°	80°	110°	250°	280°
	2	12					

Dimensions in inches (millimeters) and are subject to change without notice.

MIL-STD-1651 Insert Arrangements and Insert Positions for MIL-DTL-5015 Series III Type Filter Connectors



MIL-DTL-5015
Type

B

MIL-STD-1651 Insert Arrangements and Insert Positions							
Insert Arrg.	Contacts		A° Insert Positions				
	Qty	Size	N°	W°	X°	Y°	Z°
28-9	6	16	0°	80°	110°	250°	280°
	6	12					
28-10	3	12	0°	80°	110°	250°	280°
	2	8					
	2	4					
28-11	18	16	0°	80°	110°	250°	280°
	4	12					
28-12	26	16	0°	90°	180°	270°	-
28-17	15	16	0°	80°	110°	250°	280°
28-18	12	16	0°	70°	145°	215°	290°
28-19	6	16	0°	80°	110°	250°	280°
	4	12					
28-20	4	16	0°	80°	110°	250°	280°
	10	12					
28-21	37	16	0°	80°	110°	250°	280°
28-22	3	16	0°	70°	145°	215°	290°
	3	4					
32-1	3	12	0°	80°	110°	250°	280°
	2	0					
32-2	2	16	0°	80°	110°	250°	280°
	3	4					
32-3	4	16	0°	80°	110°	250°	280°
	2	12					
	2	4					
	1	0					
32-6	16	16	0°	80°	110°	250°	280°
	2	12					
	3	8					
	2	4					
32-7	28	16	0°	80°	125°	235°	280°
	7	12					
32-9	12	16	0°	80°	110°	250°	280°
	2	4					
32-13	18	16	0°	80°	110°	250°	280°
	5	12					
32-15	6	12	0°	35°	110°	250°	280°
	2	0					
32-17	4	4	0°	45°	110°	250°	-
32-22	54	16	0°	80°	110°	250°	280°
32-63	5	4	0°	-	-	-	-
32-73	46	16	0°	36°	-	-	-
36-3	3	12	0°	70°	145°	215°	290°
	3	0					
36-5	4	0	0°	-	120°	240°	-
36-6	4	4	0°	35°	110°	250°	325°
	2	0					

MIL-STD-1651 Insert Arrangements and Insert Positions							
Insert Arrg.	Contacts		A° Insert Positions				
	Qty	Size	N°	W°	X°	Y°	Z°
36-7	40	16	0°	80°	110°	250°	280°
	7	12					
36-8	46	16	0°	80°	110°	250°	280°
	1	12					
36-9	14	16	0°	80°	125°	235°	280°
	14	12					
	2	8					
	1	4					
36-10	48	16	0°	80°	125°	235°	280°
36-15	35	16	0°	60°	125°	245°	305°
36-52	52	16	0°	72°	144°	216°	288°
36-66	52	16	0°	80°	110°	250°	280°
	4	12					
40-1	24	16	0°	65°	130°	235°	300°
	6	12					
40-2	23	16	0°	80°	110°	250°	280°
40-3	18	16	0°	80°	110°	250°	280°
	4	12					
	1	4					
40-4	16	16	0°	80°	110°	250°	280°
	2	12					
	3	8					
	2	4					
40-5	6	12	0°	80°	110°	250°	280°
	4	8					
	2	4					
40-6	24	16	0°	80°	110°	250°	280°
	1	12					
	1	0					
40-7	18	16	0°	80°	110°	250°	280°
	2	12					
	2	0					
40-9	24	16	0°	65°	125°	225°	310°
	22	12					
	1	8					
40-10	16	16	0°	65°	125°	225°	310°
	9	8					
	4	4					
40-11	18	16	0°	65°	125°	225°	310°
	4	12					
	1	8					
	1	4					
40-56	1	0	0°	72°	144°	216°	288°
	85	16					

Dimensions in inches (millimeters) and are subject to change without notice.

© 2013 Glenair, Inc.

U.S. CAGE Code 06324

Printed in U.S.A.

MIL-DTL-5015 TYPE JAM NUT RECEPTACLE

How To Order	
Sample Part Number	240-515 J NF 36-4 SS C B X
Filter Connector	MIL-DTL-5015 Type
Shell Style	J = Jam Nut
Connector Class	See Table II
Insert Arrangement	IAW MIL-STD-1651 (See pages B-97 – B-99)
Contact Type	PS = Pin, Solder Cup SS = Socket, Solder Cup
Filter Type	C = C Circuit (See Note 1)
Capacitance	See Table III
Alternate Insert Position	Per MIL-STD-1651. W, X, Y, Z, N = Normal (See pages B-97 – B-99)

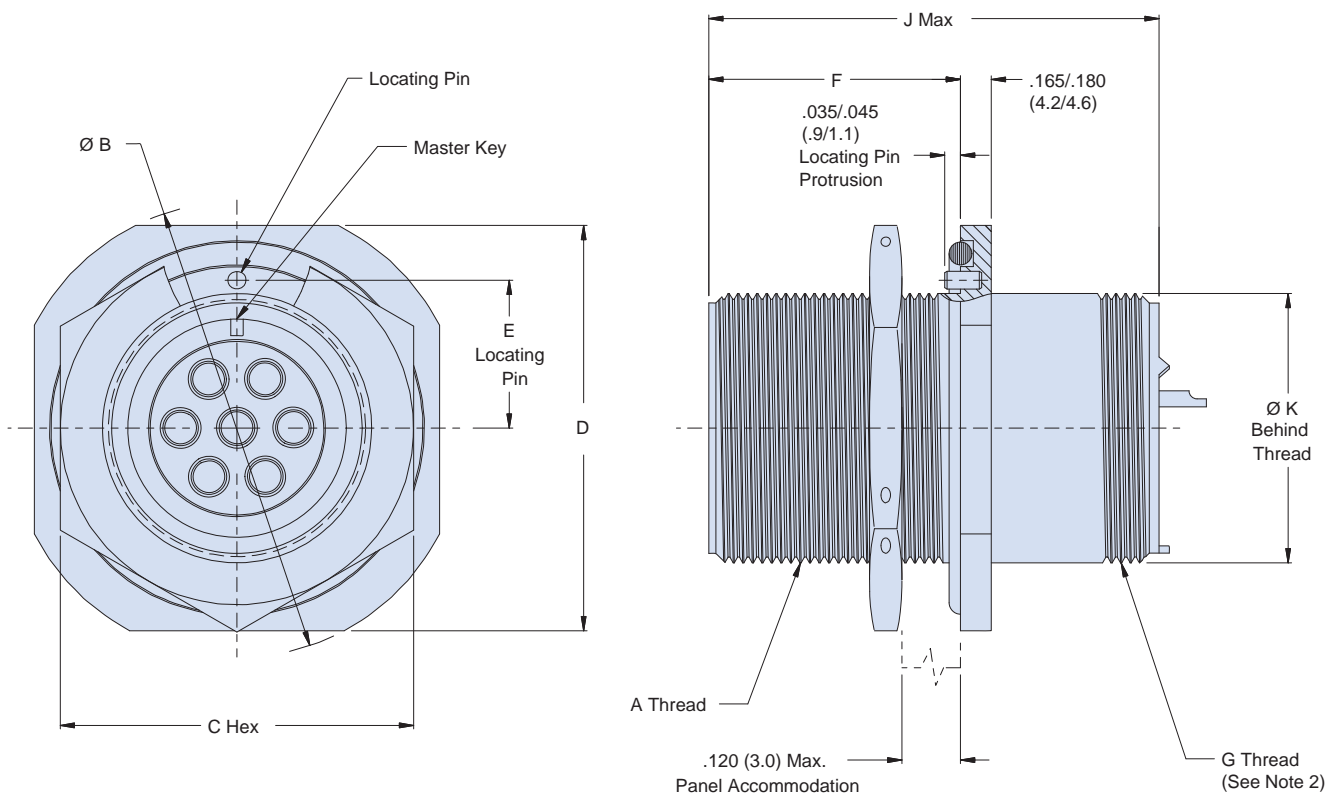

Notes

1. Other filter styles (Pi, C-L, L-C, Unbalanced Pi, Multi-Stage, Multi-Value) are available, please consult the factory.

Dimensions in inches (millimeters) and are subject to change without notice.

240-515J
MIL-DTL-5015 Series III Type Filter Connector
MS3454 Jam Nut Receptacle



MIL-DTL-5015
Type

B

Table I: Dimensions

Shell Size	A Thread 2A	Ø B ±.005 (±.13)	C Hex	D ±.005 (±.13)	E ±.005 (±.13)	F ±.005 (±.13)	G Thread 2A	J Max	Ø K
8S	.500-28 UNEF	1.272 (32.3)	.687 (17.4)	1.187 (30.1)	.323 (8.2)	.720 (18.3)	.500-20 UNF	1.800 (45.7)	.500 (12.7) .490 (12.4)
10SL	.625-24 UNEF	1.397 (35.5)	.812 (20.6)	1.312 (33.3)	.385 (9.8)	.720 (18.3)	.625-24 UNEF	1.800 (45.7)	.625 (15.9) .615 (15.6)
10SL	.625-24 UNEF	1.397 (35.5)	.812 (20.6)	1.312 (33.3)	.385 (9.8)	.720 (18.3)	.625-24 UNEF	1.800 (45.7)	.625 (15.9) .615 (15.6)
12S	.750-20 UNEF	1.522 (38.7)	.937 (23.8)	1.437 (36.5)	.448 (11.4)	.720 (18.3)	.750-20 UNEF	1.800 (45.7)	.750 (19.1) .740 (18.8)
12	.750-20 UNEF	1.522 (38.7)	.937 (23.8)	1.437 (36.5)	.448 (11.4)	.970 (24.6)	.750-20 UNEF	2.000 (50.8)	.750 (19.1) .740 (18.8)
14S	.875-20 UNEF	1.647 (41.8)	1.125 (28.6)	1.562 (39.7)	.510 (13.0)	.720 (18.3)	.875-20 UNEF	1.800 (45.7)	.875 (22.2) .865 (22.0)
14	.875-20 UNEF	1.647 (41.8)	1.125 (28.6)	1.562 (39.7)	.510 (13.0)	.970 (24.6)	.875-20 UNEF	2.000 (50.8)	.875 (22.2) .865 (22.0)
16S	1.000-20 UNEF	1.772 (45.0)	1.250 (31.8)	1.687 (42.8)	.573 (14.6)	.720 (18.3)	1.000-20 UNEF	1.800 (45.7)	1.000 (24.5) .990 (25.1)
16	1.000-20 UNEF	1.772 (45.0)	1.250 (31.8)	1.687 (42.8)	.573 (14.6)	.970 (24.6)	1.000-20 UNEF	2.000 (50.8)	1.000 (24.5) .990 (25.1)
18	1.125-18 UNEF	1.817 (46.2)	1.375 (34.9)	1.812 (46.0)	.635 (16.1)	.970 (24.6)	1.0625-18 UNEF	2.000 (50.8)	1.062 (27.0) 1.052 (26.7)
20	1.250-18 UNEF	2.022 (51.4)	1.500 (38.1)	1.937 (49.2)	.698 (17.7)	.970 (24.6)	1.1875-18 UNEF	2.000 (50.8)	1.187 (30.1) 1.177 (29.9)
22	1.375-18 UNEF	2.241 (56.9)	1.625 (41.3)	2.156 (54.8)	.760 (19.3)	.970 (24.6)	1.3125-18 UNEF	2.000 (50.8)	1.312 (33.3) 1.302 (33.1)
24	1.500-18 UNEF	2.356 (59.8)	1.750 (44.5)	2.281 (57.9)	.823 (20.9)	.970 (24.6)	1.4375-18 UNEF	2.000 (50.8)	1.437 (36.5) 1.427 (36.2)
28	1.750-18 UNS	2.616 (66.4)	2.000 (50.8)	2.531 (64.3)	.948 (24.1)	.970 (24.6)	1.750-18 UNS	2.000 (50.8)	1.750 (44.5) 1.740 (44.2)
32	2.000-18 UNS	2.856 (72.5)	2.375 (60.3)	2.781 (70.6)	1.073 (27.3)	.970 (24.6)	2.000-18 UNS	2.000 (50.8)	2.000 (50.8) 1.990 (50.5)
36	2.250-16 UN	3.118 (79.2)	2.625 (66.7)	3.031 (77.0)	1.198 (30.4)	.970 (24.6)	2.250-16 UN	2.000 (50.8)	2.250 (57.2) 2.240 (56.9)
40	2.500-16 UN	3.368 (85.5)	2.875 (73.0)	3.281 (83.3)	1.323 (33.6)	.970 (24.6)	2.500-16 UN	2.000 (50.8)	2.500 (63.5) 2.490 (63.2)

Table II: Connector Class

Sym	Material	Finish Description
ME	Aluminum	Electroless Nickel
NF		Cadmium O.D. Over Electroless Nickel
ZL	Stainless Steel	Electro-Deposited Nickel

Table III: Capacitor Array Code
Capacitance Range

Class	C - Circuit (pF)
X	80,000 - 120,000
Y	40,000 - 60,000
Z	30,000 - 45,000
A	19,000 - 28,000
B	16,000 - 22,500
C	9,000 - 16,500

Dimensions in inches (millimeters) and are subject to change without notice.

MIL-DTL-5015 TYPE WALL MOUNT RECEPTACLE

How To Order	
Sample Part Number	240-515 W NF 36-4 SS C B X
Filter Connector	MIL-DTL-5015 Type
Shell Style	W = Wall Mount
Connector Class	See Table II
Insert Arrangement	IAW MIL-STD-1651 (See pages B-97 – B-99)
Contact Type	PS = Pin, Solder Cup SS = Socket, Solder Cup
Filter Type	C = C Circuit (See Note 1)
Capacitance	See Table III
Alternate Insert Position	Per MIL-STD-1651. W, X, Y, Z, N = Normal (See pages B-97 – B-99)

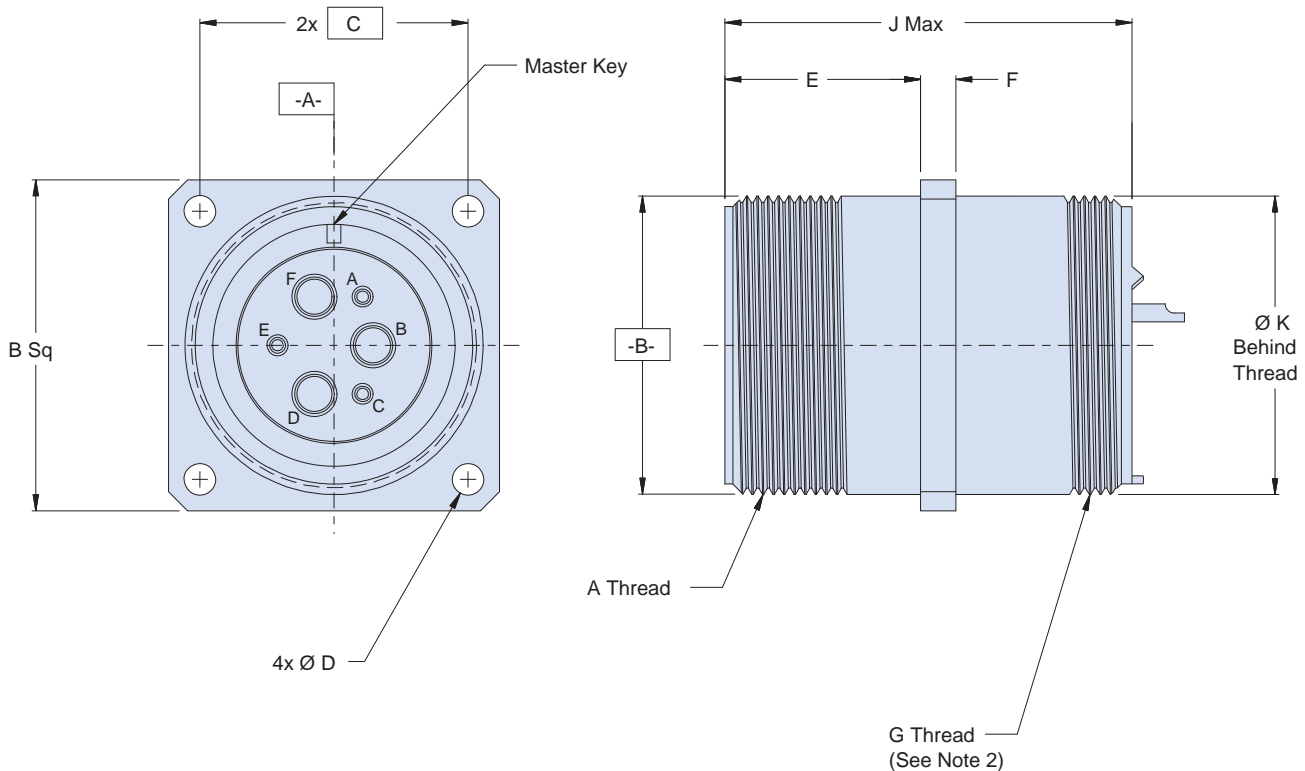

Notes

- Other filter styles (Pi, C-L, L-C, Unbalanced Pi, Multi-Stage, Multi-Value) are available, please consult the factory.

Dimensions in inches (millimeters) and are subject to change without notice.

240-515W
MIL-DTL-5015 Series III Type Filter Connector
MS3450 Wall Mount Receptacle



MIL-DTL-5015
Type

B

Table I: Dimensions

Shell Size	A Thread 2A	B ±.031 (±.79)	C Bsc	Ø D Holes	E	F ±.015 (±.38)	G Thread 2A	J Max	Ø K
8S	.500-28 UNEF	.875 (22.2)	.594 (15.1)	.130 (3.3) .115 (2.9)	.593 (15.1) .562 (14.3)	.083 (2.1)	.500-20 UNF	1.800 (45.7)	.500 (12.7) .490 (12.4)
10SL	.625-24 UNEF	1.000 (25.4)	.719 (18.3)	.130 (3.3) .115 (2.9)	.593 (15.1) .562 (14.3)	.083 (2.1)	.625-24 UNEF	1.800 (45.7)	.625 (15.9) .615 (15.6)
10SL	.625-24 UNEF	1.000 (25.4)	.719 (18.3)	.130 (3.3) .115 (2.9)	.593 (15.1) .562 (14.3)	.083 (2.1)	.625-24 UNEF	1.800 (45.7)	.625 (15.9) .615 (15.6)
12S	.750-20 UNEF	1.094 (27.8)	.812 (20.6)	.130 (3.3) .115 (2.9)	.593 (15.1) .562 (14.3)	.083 (2.1)	.750-20 UNEF	1.800 (45.7)	.750 (19.1) .740 (18.8)
12	.750-20 UNEF	1.094 (27.8)	.812 (20.6)	.130 (3.3) .115 (2.9)	.781 (19.8) .750 (19.1)	.083 (2.1)	.750-20 UNEF	2.000 (50.8)	.750 (19.1) .740 (18.8)
14S	.875-20 UNEF	1.188 (30.2)	.906 (23.0)	.130 (3.3) .115 (2.9)	.593 (15.1) .562 (14.3)	.083 (2.1)	.875-20 UNEF	1.800 (45.7)	.875 (22.2) .865 (22.0)
14	.875-20 UNEF	1.188 (30.2)	.906 (23.0)	.130 (3.3) .115 (2.9)	.781 (19.8) .750 (19.1)	.083 (2.1)	.875-20 UNEF	2.000 (50.8)	.875 (22.2) .865 (22.0)
16S	1.000-20 UNEF	1.281 (32.5)	.969 (24.6)	.130 (3.3) .115 (2.9)	.593 (15.1) .562 (14.3)	.083 (2.1)	1.000-20 UNEF	1.800 (45.7)	1.000 (24.5) .990 (25.1)
16	1.000-20 UNEF	1.281 (32.5)	.969 (24.6)	.130 (3.3) .115 (2.9)	.781 (19.8) .750 (19.1)	.083 (2.1)	1.000-20 UNEF	2.000 (50.8)	1.000 (24.5) .990 (25.1)
18	1.125-18 UNEF	1.375 (34.9)	1.062 (27.0)	.130 (3.3) .115 (2.9)	.781 (19.8) .750 (19.1)	.125 (3.2)	1.0625-18 UNEF	2.000 (50.8)	1.062 (27.0) 1.052 (26.7)
20	1.250-18 UNEF	1.500 (38.1)	1.156 (29.4)	.130 (3.3) .115 (2.9)	.781 (19.8) .750 (19.1)	.125 (3.2)	1.1875-18 UNEF	2.000 (50.8)	1.187 (30.1) 1.177 (29.9)
22	1.375-18 UNEF	1.625 (41.3)	1.250 (31.8)	.130 (3.3) .115 (2.9)	.781 (19.8) .750 (19.1)	.125 (3.2)	1.3125-18 UNEF	2.000 (50.8)	1.312 (33.3) 1.302 (33.1)
24	1.500-18 UNEF	1.750 (44.5)	1.375 (34.9)	.157 (4.0) .142 (3.6)	.843 (21.4) .812 (20.6)	.125 (3.2)	1.4375-18 UNEF	2.000 (50.8)	1.437 (36.5) 1.427 (36.2)
28	1.750-18 UNS	2.000 (50.8)	1.562 (39.7)	.157 (4.0) .142 (3.6)	.843 (21.4) .812 (20.6)	.125 (3.2)	1.750-18 UNS	2.000 (50.8)	1.750 (44.5) 1.740 (44.2)
32	2.000-18 UNS	2.250 (57.2)	1.750 (44.5)	.183 (4.6) .168 (4.3)	.906 (23.0) .875 (22.2)	.125 (3.2)	2.000-18 UNS	2.000 (50.8)	2.000 (50.8) 1.990 (50.5)
36	2.250-16 UN	2.500 (63.5)	1.938 (49.2)	.183 (4.6) .168 (4.3)	.906 (23.0) .875 (22.2)	.125 (3.2)	2.250-16 UN	2.000 (50.8)	2.250 (57.2) 2.240 (56.9)
40	2.500-16 UN	2.750 (69.9)	2.188 (55.6)	.183 (4.6) .168 (4.3)	.906 (23.0) .875 (22.2)	.125 (3.2)	2.500-16 UN	2.000 (50.8)	2.500 (63.5) 2.490 (63.2)

Table II: Connector Class

Sym	Material	Finish Description
ME	Aluminum	Electroless Nickel
NF		Cadmium O.D. Over Electroless Nickel
ZL	Stainless Steel	Electro-Deposited Nickel

Table III: Capacitor Array Code
Capacitance Range

Class	C - Circuit (pF)
X	80,000 - 120,000
Y	40,000 - 60,000
Z	30,000 - 45,000
A	19,000 - 28,000
B	16,000 - 22,500
C	9,000 - 16,500

Dimensions in inches (millimeters) and are subject to change without notice.

MIL-DTL-5015 TYPE CONNECTOR ADAPTER

How To Order								
Sample Part Number	240-515	A	ME	36-5	PS	C	B	X
Filter Connector	MIL-DTL-5015 Type							
Shell Style	A = Connector Adapter							
Connector Class	See Table II							
Insert Arrangement	IAW MIL-STD-1651. (See pages B-97 – B-99)							
Contact Gender	PS = Pins, Plug Side SP = Sockets, Plug Side							
Filter Type	C = C Circuit (See Note 1)							
Capacitance	See Table III							
Alternate Insert Position	Per MIL-STD-1651. W, X, Y, Z, N = Normal (See pages B-97 – B-99)							

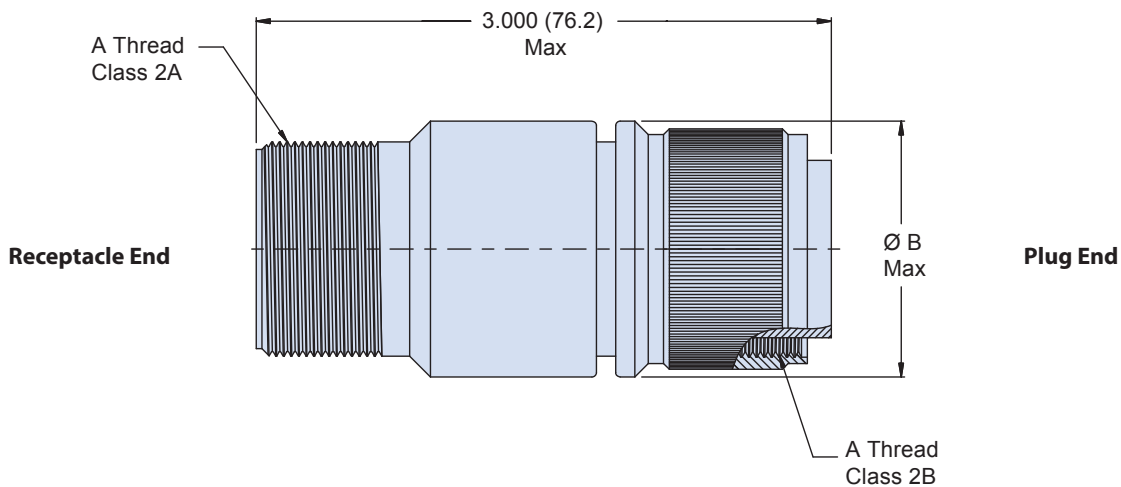

Notes

- Other filter styles (Pi, C-L, L-C, Unbalanced Pi, Multi-Stage, Multi-Value) are available, please consult the factory.
- Please consult the factory for Pin/Pin and/or Socket/Socket contact arrangements.

Dimensions in inches (millimeters) and are subject to change without notice.

240-515A
MIL-DTL-5015 Series III Type Filter Connector
Connector Adapter



MIL-DTL-5015
Type

B

Table I: Dimensions		
Shell Size	A Thread	Ø B Max
8S	.500-28 UNEF	.844 (21.4)
10S	.625-24 UNEF	.969 (24.6)
10SL	.625-24 UNEF	.969 (24.6)
12S	.750-20 UNEF	1.062 (27.0)
12	.750-20 UNEF	1.062 (27.0)
14S	.875-20 UNEF	1.156 (29.4)
14	.875-20 UNEF	1.156 (29.4)
16S	1.000-20 UNEF	1.250 (31.8)
16	1.000-20 UNEF	1.250 (31.8)
18	1.125-18 UNEF	1.344 (34.1)
20	1.250-18 UNEF	1.469 (37.3)
22	1.375-18 UNEF	1.594 (40.5)
24	1.500-18 UNEF	1.719 (43.7)
28	1.750-18 UNS	1.969 (50.0)
32	2.000-18 UNS	2.219 (56.4)
36	2.250-16 UN	2.469 (62.7)
40	2.500-16 UN	2.719 (69.1)

Table II: Connector Class		
Sym	Material	Finish Description
ME	Aluminum	Electroless Nickel
NF		Cadmium O.D. Over Electroless Nickel
ZL	Stainless Steel	Electro-Deposited Nickel

Table III: Capacitor Array Code Capacitance Range	
Class	C - Circuit (pF)
X	80,000 - 120,000
Y	40,000 - 60,000
Z	30,000 - 45,000
A	19,000 - 28,000
B	16,000 - 22,500
C	9,000 - 16,500

Dimensions in inches (millimeters) and are subject to change without notice.

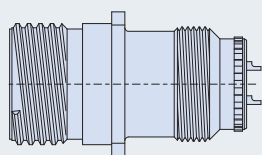
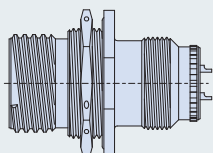
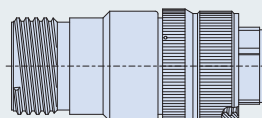
**240-288W****Wall Mount Receptacles****Page
B-108****240-288J****Jam Nut Receptacles****Page
B-110****240-288A****Connector Adapters****Page
B-112**

Notes

1. Materials/Finishes: Shells, Barrel, Coupling Nut, Jam Nut - See Table I
Insulators - high grade rigid dielectric/N.A.
Seals - Fluorosilicone
Contacts: Copper alloy 50 μ " Gold over 50 μ " Nickel
2. Assembly to be identified with Glenair's name, part number, and date code - space permitting.
3. Insert Arrangement in accordance with MIL-STD-1698. (Arrangement shown for reference only)
4. EMI Circular Filter Receptacle connectors designed to meet requirements of MIL-STD-2120 and MIL-DTL-28840.
5. All contacts to have identical filter value. Other filter arrangements available, contact factory.
6. Electrical Ratings: DWV- 500 VDC; Standard Operating Voltage 200 VDC (Filter class X, Y and Z are 250 VDC)
7. Insulation Resistance: 5000 MegOhms Min. at 200 VDC.
8. Operating Temperature -55°C to +125°C (Env Class Connectors)
9. Other filter styles (C-L, L-C, Unbalanced Pi, Multi-Stage, Multi-Value) are available, please consult the factory.

Dimensions in inches (millimeters) and are subject to change without notice.

MIL-STD-1698 Insert Arrangements (Pin Front View) Shell Polarization and Panel Cut-Outs for MIL-DTL-28840 Type Filter Connectors



MIL-DTL-28840
Type

B

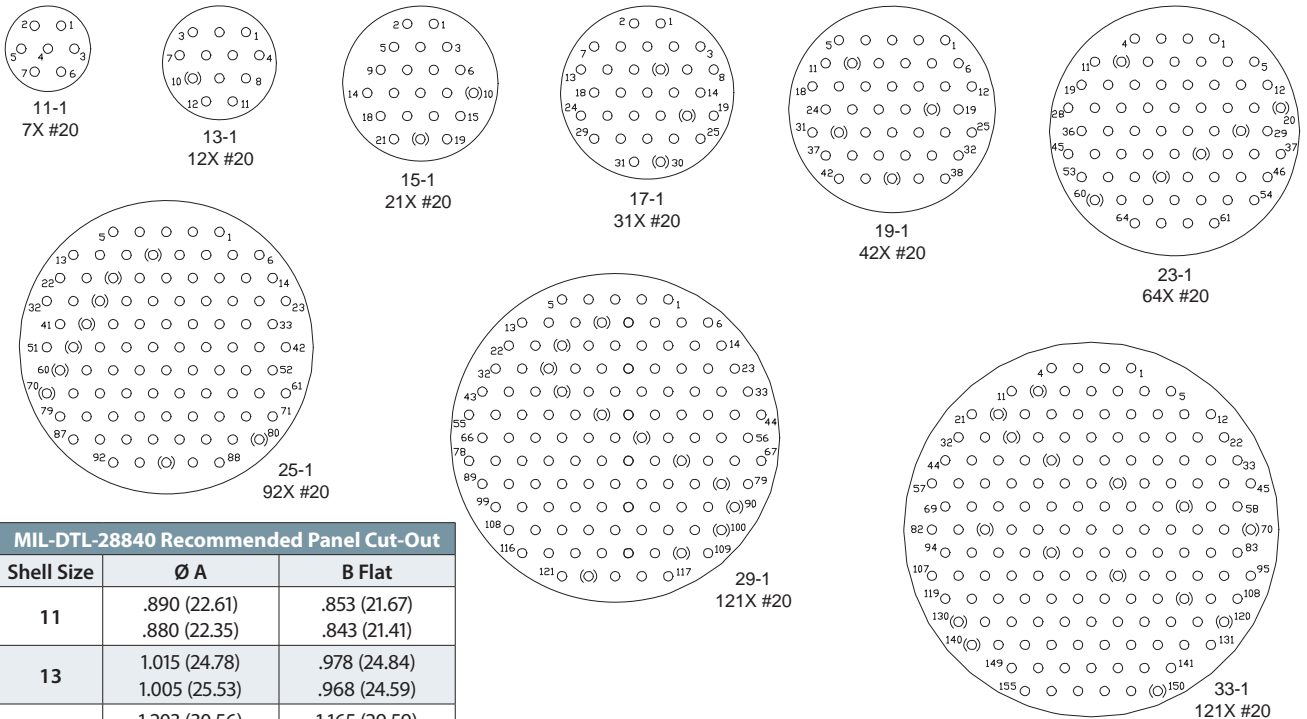

MIL-DTL-28840 Recommended Panel Cut-Out

Shell Size	Ø A	B Flat
11	.890 (22.61)	.853 (21.67)
	.880 (22.35)	.843 (21.41)
13	1.015 (24.78)	.978 (24.84)
	1.005 (25.53)	.968 (24.59)
15	1.203 (30.56)	1.165 (29.59)
	1.193 (30.30)	1.155 (29.34)
17	1.265 (32.13)	1.228 (31.19)
	1.255 (31.88)	1.218 (30.94)
19	1.453 (36.91)	1.415 (35.94)
	1.443 (36.65)	1.405 (35.69)
23	1.640 (41.66)	1.603 (40.72)
	1.630 (41.40)	1.593 (40.46)
25	1.765 (44.83)	1.728 (43.89)
	1.755 (44.58)	1.718 (43.64)
29	1.953 (49.61)	1.915 (48.64)
	1.943 (49.35)	1.905 (48.39)
33	2.140 (54.36)	2.103 (53.42)
	2.130 (54.10)	2.093 (53.16)

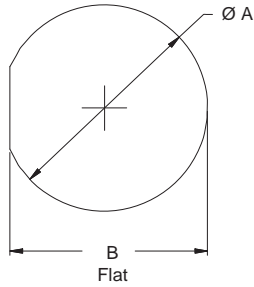

Plug

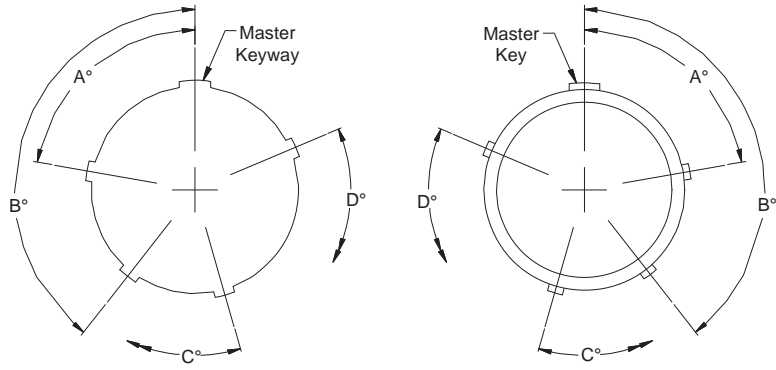

Note: All Minor Keys and Keyways are rotated to provide polarization while Master Key and Keyway remain fixed.

Table II: Alternate Keyways

Shell Size	Keying Position	A° Bsc	B° Bsc	C° Bsc	D° Bsc
11 13	1	95°	141°	208°	236°
	2	113°	156°	182°	292°
	3	90°	145°	195°	252°
	4	53°	156°	220°	255°
	5	119°	146°	176°	298°
	6	51°	141°	184°	242°
15 17	1	80°	142°	196°	293°
	2	135°	170°	200°	310°
	3	49°	169°	200°	244°
	4	66°	140°	200°	257°
	5	62°	145°	180°	280°
	6	79°	153°	197°	272°
19 23 25 29 33	1	80°	142°	196°	293°
	2	135°	170°	200°	310°
	3	49°	169°	200°	244°
	4	66°	140°	200°	257°
	5	62°	145°	180°	280°
	6	79°	153°	197°	272°

Dimensions in inches (millimeters) and are subject to change without notice.

© 2013 Glenair, Inc.

U.S. CAGE Code 06324

Printed in U.S.A.

240-288W
MIL-DTL-28840 Type Filter Connector
Wall Mount Receptacle



MIL-DTL-28840
Type

B

Table I: Connector Class

Sym	Class	Material	Finish Description
ME	Environmental	Aluminum	Electroless Nickel
MT	Environmental	Aluminum	Ni-PTFE 1000 Hour Grey™ Nickel Fluorocarbon Polymer
NF	Environmental	Aluminum	Cadmium O.D. Over Electroless Nickel
ZL	Environmental	Stainless Steel	Electro-Deposited Nickel
ZN	Environmental	Aluminum	Zinc-Nickel, Olive Drab
ZR	Environmental	Aluminum	Zinc Nickel, Black - RoHS
H2*	Hermetic	Stainless Steel	Electro-Deposited Nickel

*Some dimensions do not apply. See drawing 240-288WH2

Table II: Capacitor Array Code Capacitance Range

Class	Pi - Circuit (pF)	C - Circuit (pF)
X*	160,000 - 240,000	80,000 - 120,000
Y*	80,000 - 120,000	40,000 - 60,000
Z*	60,000 - 90,000	30,000 - 45,000
A	38,000 - 56,000	19,000 - 28,000
B	32,000 - 45,000	16,000 - 22,500
C	18,000 - 33,000	9,000 - 16,500
D	8,000 - 12,000	4,000 - 6,000
E	3,300 - 5,000	1,650 - 2,500
F	800 - 1,300	400 - 650
G	400 - 600	200 - 300
J	70-120	35-60

* Filter Classes X, Y and Z are 250 VDC.
 All others are 500 VDC

Table III: Dimensions

Shell Size	A Sq.	B Bsc	Ø C Holes	D Thread Class 2A	F Thread Class 2A	Ø G Ref
11	1.043 (26.49)	.750 (19.05)	.130 (3.30)	.750-1P-.2L-DS	.7500-20 UNEF	.812 (20.62)
	1.003 (25.48)		.115 (2.92)			
13	1.158 (29.41)	.843 (21.41)	.130 (3.30)	.875-1P-.2L-DS	.8750-20 UNEF	.937 (23.80)
	1.118 (28.40)		.115 (2.92)			
15	1.278 (32.46)	.968 (24.59)	.130 (3.30)	1.062-1P-.2L-DS	1.0000-20 UNEF	1.124 (28.55)
	1.238 (31.45)		.115 (2.92)			
17	1.403 (35.64)	1.015 (25.78)	.130 (3.30)	1.125-1P-.2L-DS	1.1250-18 UNEF	1.187 (30.15)
	1.363 (34.62)		.115 (2.92)			
19	1.528 (38.81)	1.140 (28.96)	.130 (3.30)	1.312-1P-.2L-DS	1.2500-18 UNEF	1.374 (34.90)
	1.488 (37.80)		.115 (2.92)			
23	1.738 (44.15)	1.281 (32.54)	.130 (3.30)	1.500-1P-.2L-DS	1.4375-18 UNEF	1.562 (39.67)
	1.698 (43.13)		.115 (2.92)			
25	1.838 (46.69)	1.392 (35.36)	.157 (3.99)	1.625-1P-.2L-DS	1.5625-18 UNEF	1.687 (42.85)
	1.798 (45.67)		.142 (3.61)			
29	2.158 (54.81)	1.568 (39.83)	.157 (3.99)	1.812-1P-.2L-DS	1.8750-16 UN	1.874 (47.60)
	2.118 (53.80)		.142 (3.61)			
33	2.348 (59.64)	1.734 (44.04)	.183 (4.65)	2.000-1P-.2L-DS	2.0625-16 UNS	2.062 (52.37)
	2.308 (58.62)		.168 (4.27)			

Dimensions in inches (millimeters) and are subject to change without notice.



240-288J
MIL-DTL-28840 Type Filter Connector
Jam Nut Receptacle

B

MIL-DTL-28840 TYPE JAM NUT RECEPTACLE

How To Order										
Sample Part Number	240-288				J	ME	19-1	P	P	A N 1
Filter Connector	MIL-DTL-28840 Type									
Shell Style	J = Jam Nut									
Connector Class	See Table I									
Insert Arrangement	IAW MIL-STD-1698. (See page B-107)									
Contact Gender	P = Pin/22 GA Solder Cup F = Pin/20 GA Solder Cup D = Pin/28 GA Solder Cup S = Socket/22 GA Solder Cup G = Socket/20 GA Solder Cup E = Socket/28 GA Solder Cup									
Filter Type	P = Pi Circuit C = C Circuit (See Note 1)									
Capacitance	See Table II									
Flange Mounting Style	N = Not Applicable									
Alternate Key Position	1, 2, 3, 4, 5, 6 (See page B-107)									

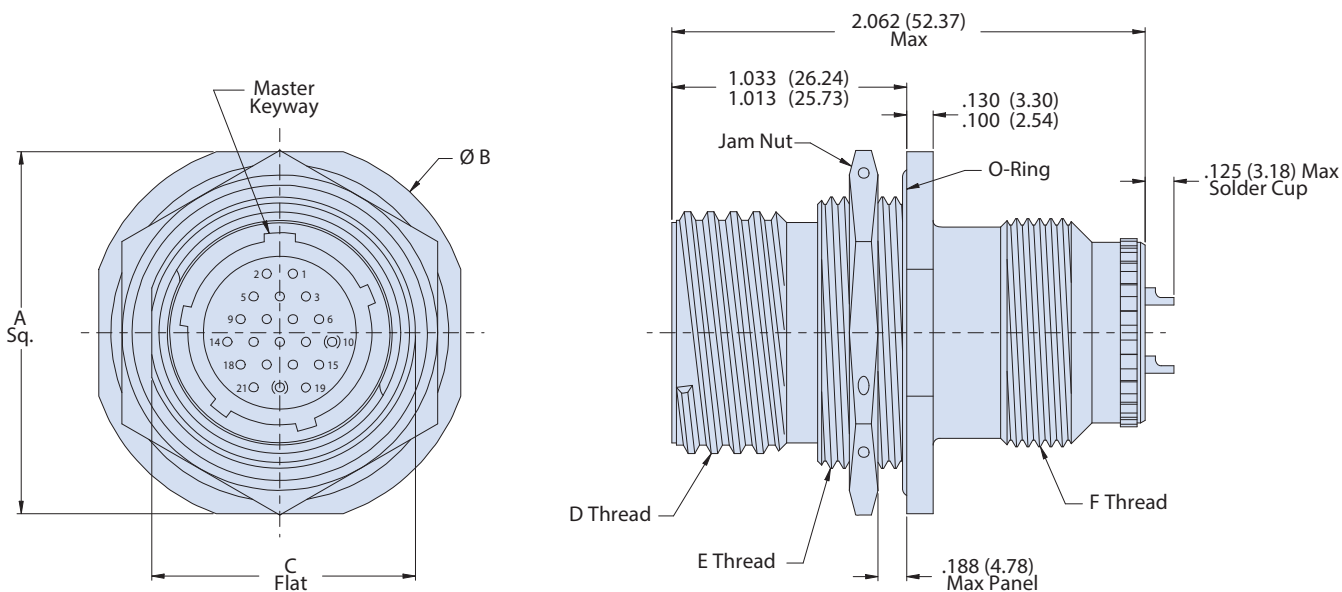

Notes

1. Other filter styles (C-L, L-C, Unbalanced Pi, Multi-Stage, Multi-Value) are available, please consult the factory.

Dimensions in inches (millimeters) and are subject to change without notice.

240-288J
MIL-DTL-28840 Type Filter Connector
Jam Nut Receptacle



MIL-DTL-28840
Type

B

Table I: Connector Class

Sym	Class	Material	Finish Description
ME	Environmental	Aluminum	Electroless Nickel
MT	Environmental	Aluminum	Ni-PTFE 1000 Hour Grey™ Nickel Fluorocarbon Polymer
NF	Environmental	Aluminum	Cadmium O.D. Over Electroless Nickel
ZL	Environmental	Stainless Steel	Electro-Deposited Nickel
ZN	Environmental	Aluminum	Zinc-Nickel, Olive Drab
ZR	Environmental	Aluminum	Zinc Nickel, Black - RoHS
H2*	Hermetic	Stainless Steel	Electro-Deposited Nickel

*Some dimensions do not apply. See drawing 240-288JH2

Table II: Capacitor Array Code Capacitance Range

Class	Pi - Circuit (pF)	C - Circuit (pF)
X*	160,000 - 240,000	80,000 - 120,000
Y*	80,000 - 120,000	40,000 - 60,000
Z*	60,000 - 90,000	30,000 - 45,000
A	38,000 - 56,000	19,000 - 28,000
B	32,000 - 45,000	16,000 - 22,500
C	18,000 - 33,000	9,000 - 16,500
D	8,000 - 12,000	4,000 - 6,000
E	3,300 - 5,000	1,650 - 2,500
F	800 - 1,300	400 - 650
G	400 - 600	200 - 300
J	70-120	35-60

* Filter Classes X, Y and Z are 250 VDC.
 All others are 500 VDC

Table III: Dimensions

Shell Size	A Sq.	Ø B	C Flat	D Thread Class 2A	E Thread Class 2A	F Thread Class 2A
11	1.274 (32.36)	1.368 (34.75)	.841 (21.36)	.750-.1P-.2L-DS	.8750-20 UNEF	.7500-20 UNEF
	1.254 (31.85)	1.348 (34.24)	.832 (21.13)			
13	1.399 (35.53)	1.508 (38.30)	.966 (24.54)	.875-.1P-.2L-DS	1.0000-20 UNEF	.8750-20 UNEF
	1.379 (35.03)	1.488 (37.80)	.957 (24.31)			
15	1.587 (40.31)	1.681 (42.70)	1.153 (29.29)	1.062-.1P-.2L-DS	1.1875-18 UNEF	1.0000-20 UNEF
	1.567 (39.80)	1.661 (42.19)	1.144 (29.06)			
17	1.649 (41.88)	1.743 (44.27)	1.216 (30.89)	1.125-.1P-.2L-DS	1.2500-18 UNEF	1.1250-18 UNEF
	1.629 (41.38)	1.723 (43.76)	1.207 (30.66)			
19	1.837 (46.66)	1.931 (49.05)	1.403 (35.64)	1.312-.1P-.2L-DS	1.4375-18 UNEF	1.2500-18 UNEF
	1.817 (46.15)	1.911 (48.54)	1.394 (35.41)			
23	2.024 (51.41)	2.118 (53.80)	1.591 (40.41)	1.500-.1P-.2L-DS	1.6250-18 UNEF	1.4375-18 UNEF
	2.004 (50.90)	2.098 (53.29)	1.582 (40.18)			
25	2.149 (54.58)	2.243 (56.97)	1.716 (43.59)	1.625-.1P-.2L-DS	1.7500-18 UNS	1.5625-18 UNEF
	2.129 (54.08)	2.223 (56.46)	1.707 (43.36)			
29	2.337 (59.36)	2.435 (61.85)	1.903 (48.34)	1.812-.1P-.2L-DS	1.9375-16 UN	1.8750-16 UN
	2.317 (58.85)	2.415 (61.34)	1.894 (48.11)			
33	2.524 (64.11)	2.618 (66.50)	2.091 (53.11)	2.000-.1P-.2L-DS	2.1250-16 UN	2.0625-16 UNS
	2.504 (63.60)	2.598 (65.99)	2.082 (52.88)			

Dimensions in inches (millimeters) and are subject to change without notice.

240-288A
MIL-DTL-28840 Type Filter Connector
Connector Adapter



MIL-DTL-28840
Type

B

Table I: Connector Class

Sym	Class	Material	Finish Description
ME	Environmental	Aluminum	Electroless Nickel
MT	Environmental	Aluminum	Ni-PTFE 1000 Hour Grey™ Nickel Fluorocarbon Polymer
NF	Environmental	Aluminum	Cadmium O.D. Over Electroless Nickel
ZL	Environmental	Stainless Steel	Electro-Deposited Nickel
ZN	Environmental	Aluminum	Zinc-Nickel, Olive Drab
ZR	Environmental	Aluminum	Zinc Nickel, Black - RoHS

Table II: Capacitor Array Code Capacitance Range

Class	Pi - Circuit (pF)	C - Circuit (pF)
X*	160,000 - 240,000	80,000 - 120,000
Y*	80,000 - 120,000	40,000 - 60,000
Z*	60,000 - 90,000	30,000 - 45,000
A	38,000 - 56,000	19,000 - 28,000
B	32,000 - 45,000	16,000 - 22,500
C	18,000 - 33,000	9,000 - 16,500
D	8,000 - 12,000	4,000 - 6,000
E	3,300 - 5,000	1,650 - 2,500
F	800 - 1,300	400 - 650
G	400 - 600	200 - 300
J	70-120	35-60

* Filter Classes X, Y and Z are 250 VDC.
All others are 500 VDC

TABLE III: DIMENSIONS

Shell Size	A Thread Class 2A	B Thread Class 2B	Ø C Max
11	.750-.1P-.2L-DS	.750-.1P-.2L-DS	1.028 (26.11)
13	.875-.1P-.2L-DS	.875-.1P-.2L-DS	1.141 (28.98)
15	1.062-.1P-.2L-DS	1.062-.1P-.2L-DS	1.263 (32.08)
17	1.125-.1P-.2L-DS	1.125-.1P-.2L-DS	1.387 (35.23)
19	1.312-.1P-.2L-DS	1.312-.1P-.2L-DS	1.513 (38.43)
23	1.500-.1P-.2L-DS	1.500-.1P-.2L-DS	1.703 (43.26)
25	1.625-.1P-.2L-DS	1.625-.1P-.2L-DS	1.825 (46.36)
29	1.812-.1P-.2L-DS	1.812-.1P-.2L-DS	2.143 (54.43)
33	2.000-.1P-.2L-DS	2.000-.1P-.2L-DS	2.329 (59.16)

Dimensions in inches (millimeters) and are subject to change without notice.

SERIES 80



Mighty Mouse Filter Connectors

Ultra small and lightweight EMI/EMP filter connectors



Glenair's filtered Series 80 Mighty Mouse connectors provide significant size and weight savings compared to larger "MS" connectors. The high density #23 contacts provide almost double the density of D38999. Designed to meet stringent aerospace performance requirements, these connectors are offered with standard low pass Pi or C circuit filter arrays, or with customized filters to meet your specific needs. Thermally conductive epoxy protects the filter package from mechanical and heat stress and also provides a waterproof seal. These filtered receptacles mate to Series 801 stub ACME threaded, Series 804 Push-Pull, Series 805 Triple-Start and Series 800 UN threaded, and are available in jam nut, square flange and connector adapter versions.



Glenair, Inc.
1211 Air Way
Glendale, CA
91201-2497
818-247-6000
sales@glenair.com
www.glenair.com

Series 80 Mighty Mouse Filter Connectors



Product Selection Guide

240-801
Page C-8

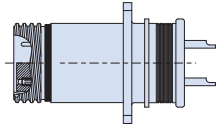

Series 801 Mighty Mouse Filter Connector
High Density, Quick Coupling Threads

240-801-12
Page C-12

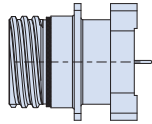

Series 801 Mighty Mouse Filter Connector
Dual-Flange Wall-Mount Receptacle

240-801-18
Page C-14

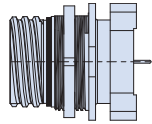

Series 801 Mighty Mouse Filter Connector
Dual-Flange Jam Nut Receptacle

240-801-AA
Page C-16

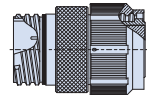

Series 801 Mighty Mouse Filter Connector Adapter
High Density, Quick Coupling Threads

240-804
Page C-18

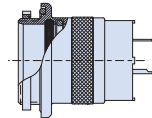

Series 804 Mighty Mouse Filter Connector
Jam Nut Receptacle, Push-Pull Quick Disconnect

240-805
Page C-20

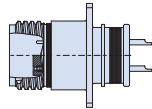

Series 805 Mighty Mouse Filter Connector
Receptacles with Triple-Start ACME Coupling Threads,
Solder Cup Contacts and Banding Platform

240-805
Page C-21

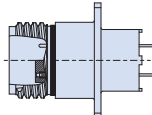

Series 805 Mighty Mouse Filter Connector
Receptacles with Triple-Start ACME Coupling Threads,
PCB Contacts

240-805-12
Page C-24

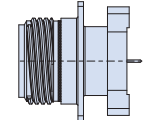

Series 805 Mighty Mouse Filter Connector
Dual-Flange Wall-Mount Receptacle

240-805-18
Page C-26

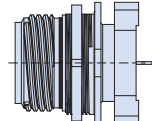

Series 805 Mighty Mouse Filter Connector
Dual-Flange Jam Nut Receptacle

240-805-AA
Page C-28

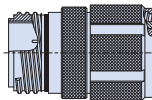

Series 805 Mighty Mouse Filter Connector Adapter
with Triple-Start ACME Coupling Threads

240-800
Page C-30

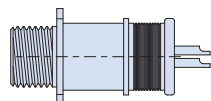

Series 800 Mighty Mouse Filter Connector
Receptacles with UN Mating Threads, Square Flange or Jam Nut

Dimensions in inches (millimeters) and are subject to change without notice.

Series 80 Mighty Mouse Filter Connector Normal and Alternate Key Positions

Plug
Key Positions

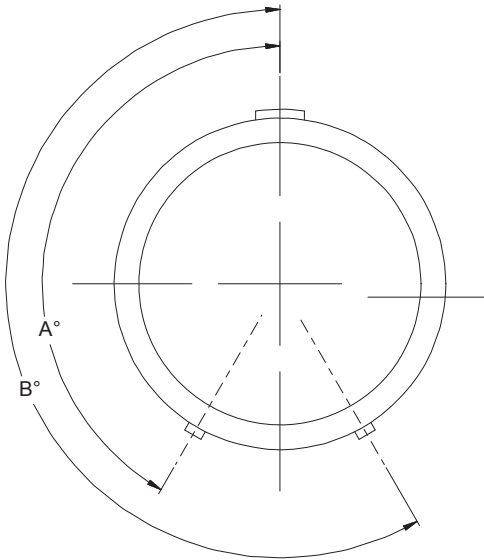

SERIES 801 804 805

Receptacle
Keyway Positions

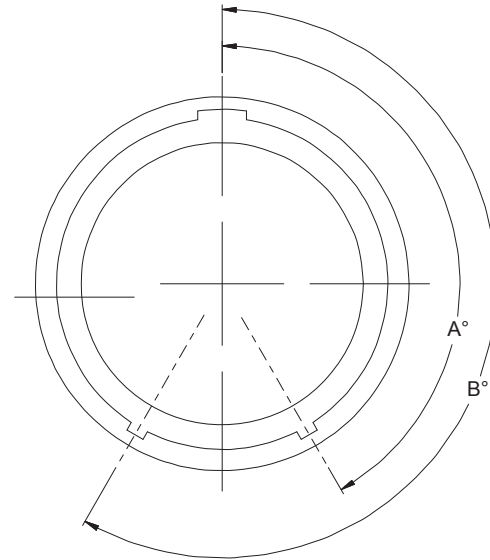

Series 80 Mighty Mouse
Alternate Key Positions

Key Position	Notes	A°	B°
A	Normal	150°	210°
B	Alternate #1	75°	210°
C	Alternate #2	95°	230°
D	Alternate #3	140°	275°
E	Alternate #4	75°	275°
F	Alternate #5	95°	210°
U	Universal	-	-

Notes

- Materials/Finishes: Shells, Barrel, Coupling Nut, Jam Nut - See Table I
Insulators - High grade rigid dielectric/N.A.
Seals - Fluorosilicone
Contacts: Copper alloy 50μ" Gold over 50μ" Nickel
- Assembly to be identified with Glenair's name, part number, and date code - space permitting.
- All contacts to have identical filter value. Other filter arrangements available, contact factory.
- Electrical Ratings: DWV- 300 VDC; Standard Operating Voltage 200 VDC (Filter class X, Y and Z are 250 VDC)
- Insulation Resistance: 5000 MegOhms Min. at 200 VDC.
- Operating Temperature: -55°C to +125°C (Env Class Connectors)
- Other filter styles (C-L, L-C, Unbalanced Pi, Multi-Stage, Multi-Value) are available, please consult the factory.

Dimensions in inches (millimeters) and are subject to change without notice.

Series 80 Mighty Mouse Filter Connector Contact Arrangements



Series 80 Mighty Mouse Contact Arrangements								
Contact Size	Contact Quantity					Contact Arrangements		
	#23	#20	#20HD	#16	#12	Series 801	Series 804	Series 805
Size #23 Contacts 5 Amp Max	3					5-3	5-3	N/A
	4					6-4	6-4	8-4
	6					6-6	6-6	8-6
	7					6-7	6-7	8-7
	10					7-10	7-10	9-10
	13					8-13	8-13	10-13
	19					9-19	9-19	11-19
	26					10-26	10-26	12-26
	31					11-31	11-31	13-31
	37					13-37	12-37	15-37
	55					16-55	14-55	18-55
	85					17-85	15-85	19-85
	100					19-100	N/A	21-100
130					21-130	N/A	23-130	
Size #20HD Contacts 7.5 Amp Max			3			6-23	6-23	8-23
			5			7-25	7-25	9-25
			8			8-28	8-28	10-28
			10			9-210	9-210	11-210
			20			13-220	12-220	15-220
			35			16-235	14-235	18-235
			41			17-241	15-241	19-241
			55			19-255	N/A	21-255
Size #16 Contacts 13 Amp Max				1		6-1	6-1	8-1
				2		8-2	8-2	10-2
				4		9-4	9-4	11-4
				5		10-5	10-5	12-5
				7		13-7	12-7	15-7
				12		16-12	14-12	18-12
				14		17-14	15-14	19-14
				19		19-19	N/A	21-19
Size #12 Contacts 23 Amp Max					1	7-1	7-1	9-1
					2	10-2	10-2	12-2
					2	13-2	12-2	15-2
					3	13-3	12-3	15-3
					5	16-5	14-5	18-5
					7	17-7	15-7	19-7
					12	21-12	N/A	23-12
Mixed Size "Combo" Layouts	4	2				8-200	8-200	10-200
	8	2				9-201	9-201	11-201
	4			2		9-200	9-200	11-200
	8			2		10-202	10-202	12-202
	4				2	10-201	10-201	12-201
	6				2	13-200	12-200	15-200
	10				2	13-201	12-201	15-201
	12				1	10-200	10-200	12-200

Dimensions in inches (millimeters) and are subject to change without notice.

Series 80 Mighty Mouse Filter Connector Contact Arrangements (Pin Front View) with Printed Circuit Board Dimensions

Series 801	5-3	6-4	6-6	6-7	6-23	6-1
Series 804	5-3	6-4	6-6	6-7	6-23	6-1
Series 805	N/A	8-4	8-6	8-7	8-23	8-1
Series 801	7-10	7-25	7-1	8-13	8-28	
Series 804	7-10	7-25	7-1	8-13	8-28	
Series 805	9-10	9-25	9-1	10-13	10-28	
Series 801	8-2	8-200	9-19	9-4	9-210	9-200
Series 804	8-2	8-200	9-19	9-4	9-210	9-200
Series 805	10-2	10-200	11-19	11-4	11-210	11-200
Series 801	9-201	10-26	10-5	10-2		
Series 804	9-201	10-26	10-5	10-2		
Series 805	11-201	12-26	12-5	12-2		

Dimensions in inches (millimeters) and are subject to change without notice.

Series 80 Mighty Mouse Filter Connector Contact Arrangements (Pin Front View) with Printed Circuit Board Dimensions



Series 801	10-200	10-201	10-202	11-31	13-37
Series 804	10-200	10-201	10-202	11-31	12-37
Series 805	12-200	12-201	12-202	13-31	15-37
Series 801	13-7	13-2	13-3	13-200	13-201
Series 804	12-7	12-2	12-3	12-200	12-201
Series 805	15-7	15-2	15-3	15-200	15-201
Series 801	13-220	16-55	16-235		
Series 804	12-220	14-55	14-235		
Series 805	15-220	18-55	18-235		

Dimensions in inches (millimeters) and are subject to change without notice.



Series 80 Mighty Mouse Filter Connector Contact Arrangements (Pin Front View) with Printed Circuit Board Dimensions

Series 801	16-5	16-12	17-7	17-14
Series 804	14-5	14-12	15-7	15-14
Series 805	18-5	18-12	19-7	19-14
Series 801	17-85	17-241		
Series 804	15-85	15-241		
Series 805	19-85	19-241		
Series 801	19-100	19-255	19-19	
Series 804	N/A	N/A	N/A	
Series 805	21-100	21-255	21-19	

Dimensions in inches (millimeters) and are subject to change without notice.

Series 80 Mighty Mouse Filter Connector Contact Arrangements (Pin Front View) with Printed Circuit Board Dimensions



Mighty Mouse

C

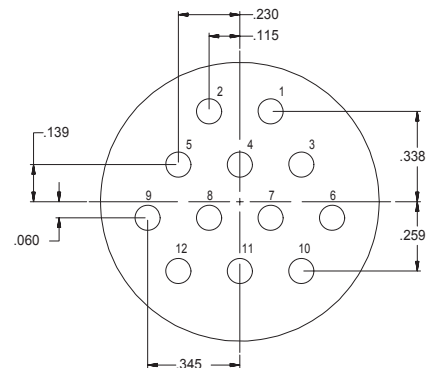
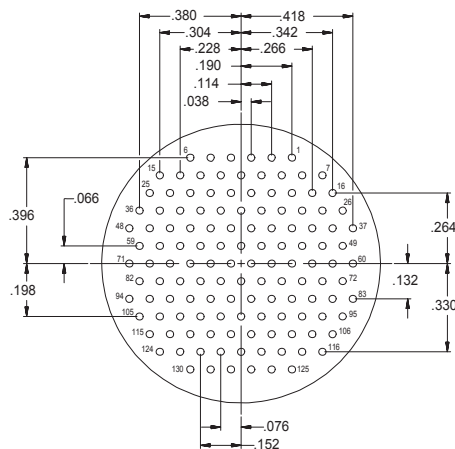

Series 801	21-130	21-12
Series 804	N/A	N/A
Series 805	23-130	23-12

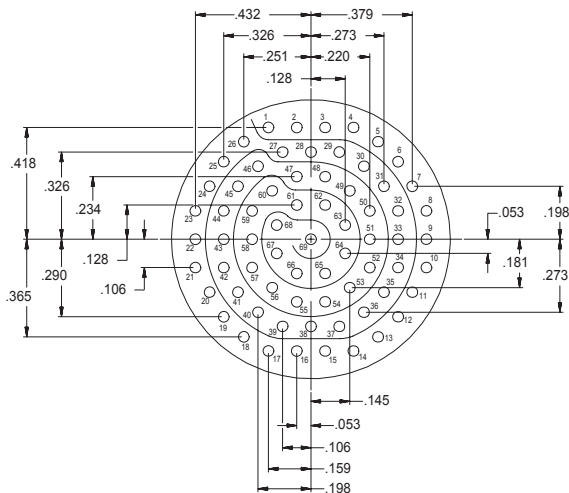
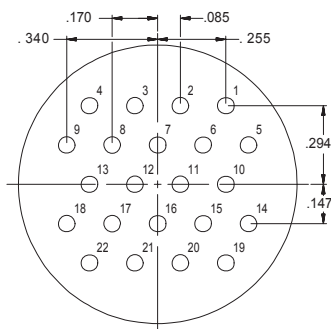

Series 801	21-22	21-269
Series 804	N/A	N/A
Series 805	23-22	23-269

Dimensions in inches (millimeters) and are subject to change without notice.

© 2013 Glenair, Inc.

EMI/EMP Filter Connectors

U.S. CAGE Code 06324

Rev. 06.02.15

Printed in U.S.A.

MIGHTY MOUSE FILTER CONNECTOR WITH SOLDER CUP CONTACTS AND BANDING PLATFORM

How To Order												
Sample Part Number	240-801-				07	M	6-7	P	S	P	A	A
Filter Connector	Series 801 Mighty Mouse											
Shell Style	01 = Square flange receptacle with solder cup contacts and banding platform		07 = Jam nut receptacle with solder cup contacts and banding platform									
Shell Material/Finish	See Table I											
Insert Arrangement	See pages C-3 – C-7											
Contact Gender	P = Pin S = Socket											
Termination Type	S = Solder Cup											
Filter Type	P = Pi Circuit C = C Circuit (See Note 1)											
Capacitance	See Table II											
Alternate Key Position	A, B, C, D, E, F, U A = Normal, U = Universal (See page C-2)											

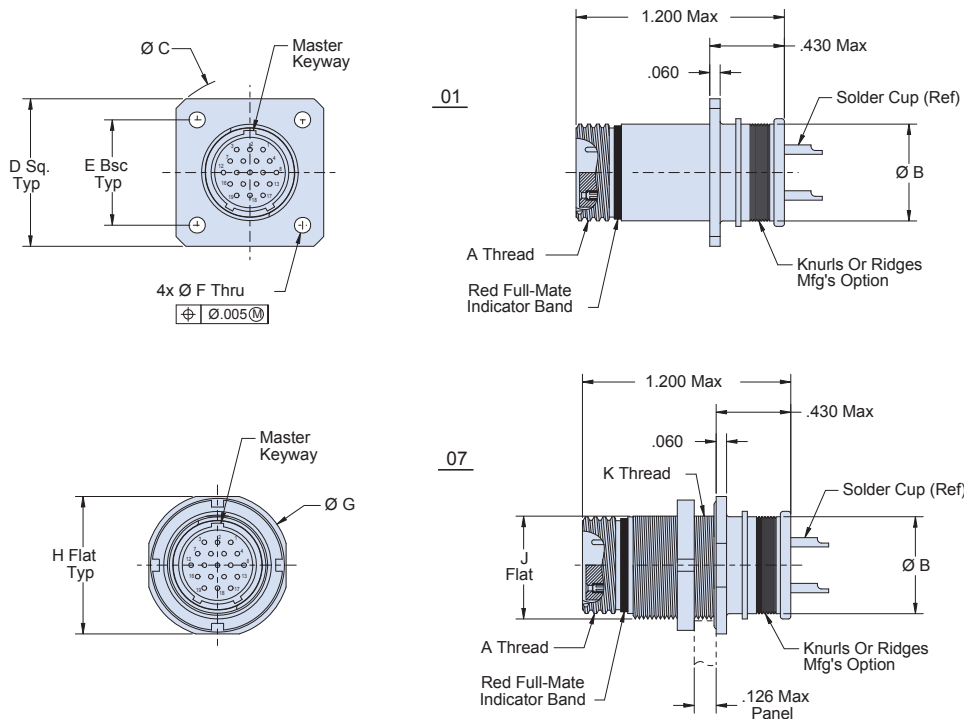

Notes

- Other filter styles (C-L, L-C, Unbalanced Pi, Multi-Stage, Multi-Value) are available, please consult the factory.

Dimensions in inches (millimeters) and are subject to change without notice.

240-801

Series 801 Mighty Mouse Filter Connector
High Density, Quick Coupling Threads



Mighty Mouse

C

MIGHTY MOUSE FILTER CONNECTOR WITH PCB CONTACTS

How To Order	
Sample Part Number	240-801- 02 M 6-7 P P P A A
Filter Connector	Series 801 Mighty Mouse
Shell Style	02 = Square flange receptacle with PCB contacts 08 = Jam nut receptacle with PCB contacts
Shell Material/Finish	See Table I
Insert Arrangement	See pages C-3 – C-7
Contact Gender	P = Pin S = Socket
Termination Type	P = PC Tail
Filter Type	P = Pi Circuit C = C Circuit (See Note 1)
Capacitance	See Table II
Alternate Key Position	A, B, C, D, E, F, U A = Normal, U = Universal (See page C-2)

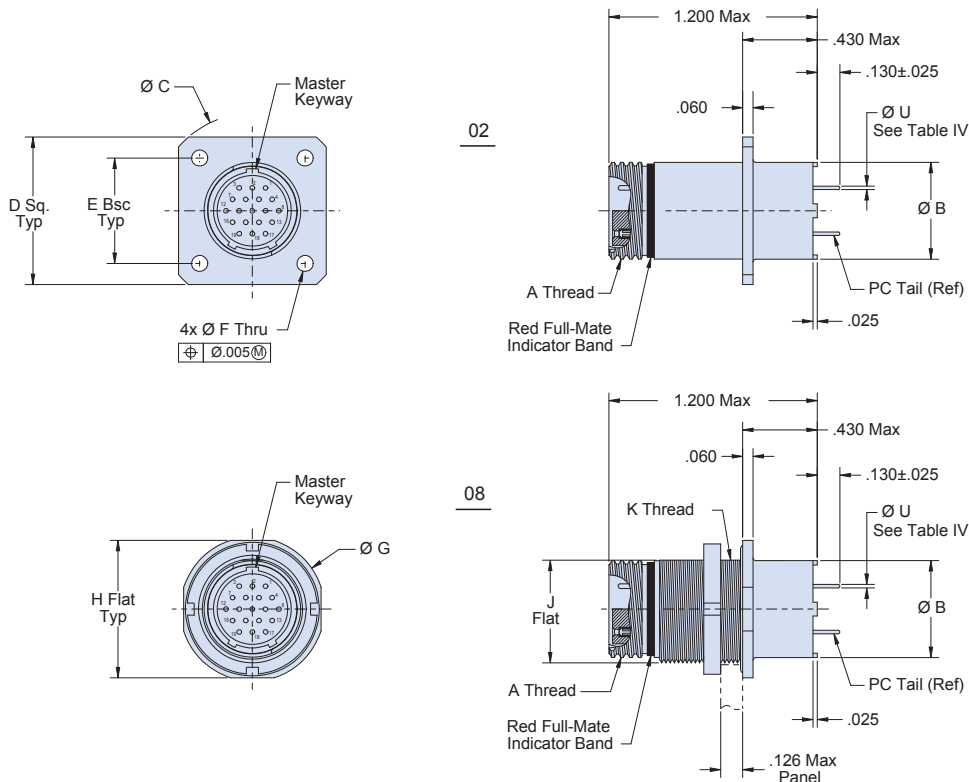

Notes

1. Other filter styles (C-L, L-C, Unbalanced Pi, Multi-Stage, Multi-Value) are available, please consult the factory.

Dimensions in inches (millimeters) and are subject to change without notice.

© 2013 Glenair, Inc.

EMI/EMP Filter Connectors

U.S. CAGE Code 06324

Rev. 06.02.15

Printed in U.S.A.



240-801

Series 801 Mighty Mouse Filter Connector High Density, Quick Coupling Threads

MIGHTY MOUSE FILTER CONNECTOR WITH SOLDER CUP CONTACTS AND BANDING PLATFORM

Table I: Connector Class

Sym	Material	Finish Description
M	Aluminum	Electroless Nickel
MT		Ni-PTFE 1000 Hour Grey™ Nickel Fluorocarbon Polymer
NF		Cadmium, Olive Drab over Electroless Nickel
ZN		Zinc-Nickel, Olive Drab
ZR		Zinc-Nickel, Black - RoHS
ZL	Stainless Steel	Electro-Deposited Nickel

Table IV:
PC Tail Dia

Contact Size	Ø U
23	.022 (0.56)
	.018 (0.46)
20	.028 (0.71)
	.024 (0.61)
16	.042 (1.07)
	.038 (0.97)
12	.096 (2.44)
	.092 (2.34)

Table II: Capacitor Array Code Capacitance Range

Class	Pi - Circuit (pF)	C - Circuit (pF)
A	38,000 - 56,000	19,000 - 28,000
B	32,000 - 45,000	16,000 - 22,500
C	18,000 - 33,000	9,000 - 16,500
D	8,000 - 12,000	4,000 - 6,000
E	3,300 - 5,000	1,650 - 2,500
F	800 - 1,300	400 - 650
G	400 - 600	200 - 300
J	70 - 120	35 - 60

Table III: Dimensions

Shell Size	A Thread	B Dia	C Dia	D Sq	E Bsc	F Holes	G Dia	H Flat	J Flat	K Thread
5	.3125-.05P-.1L-DS-2A	.365 (9.3)	.680 (17.3)	.530 (13.5)	.363 (9.2)	.096 (2.4) .091 (2.3)	.575 (14.6)	.545 (13.8)	.350 (8.9)	.3750-28 UN-2A
6	.3750-.05P-.1L-DS-2A	.409 (10.4)	.750 (19.1)	.590 (15.0)	.423 (10.7)		.635 (16.1)	.595 (15.1)	.410 (10.4)	.4375-28 UNEF-2A
7	.4375-.05P-.1L-DS-2A	.500 (12.7)	.850 (21.6)	.650 (16.5)	.483 (12.3)		.755 (19.2)	.723 (18.4)	.536 (13.6)	.5625-32 UN-2A
8	.5000-.05P-.1L-DS-2A	.522 (13.3)	.938 (23.8)	.712 (18.1)	.545 (13.8)		.755 (19.2)	.723 (18.4)	.536 (13.6)	.5625-32 UN-2A
9	.5625-.05P-.1L-DS-2A	.610 (15.5)	1.125 (28.6)	.850 (21.6)	.607 (15.4)		.830 (21.1)	.790 (20.1)	.596 (15.1)	.6250-28 UN-2A
10	.6250-.05P-.1L-DS-2A	.652 (16.6)	1.188 (30.2)	.890 (22.6)	.670 (17.0)	.130 (3.3) .126 (3.2)	.890 (22.6)	.855 (21.7)	.658 (16.7)	.6875-28 UN-2A
11	.6875-.05P-.1L-DS-2A	.694 (17.6)	1.250 (31.8)	.935 (23.8)	.715 (18.2)		.960 (24.4)	.925 (23.5)	.718 (18.2)	.750-28 UN-2A
13	.8125-.1P-.2L-DS-2A	.746 (18.9)	1.375 (34.9)	1.030 (26.2)	.812 (20.6)		1.078 (27.4)	1.044 (26.5)	.845 (21.5)	.875-28 UN-2A
16	1.000-.1P-.2L-DS-2A	.871 (22.1)	1.625 (41.3)	1.219 (31.0)	.981 (24.9)		1.264 (32.1)	1.230 (31.2)	1.022 (26.0)	1.0625-20 UN-2A
17	1.062-.1P-.2L-DS-2A	.965 (24.5)	1.700 (43.2)	1.280 (32.5)	1.060 (26.9)		1.325 (33.7)	1.290 (32.8)	1.096 (27.8)	1.125-28 UN-2A
19	1.1875-.1P-.2L-DS-2A	1.078 (27.4)	1.900 (48.3)	1.432 (36.8)	1.191 (30.3)		1.450 (36.8)	1.415 (35.9)	1.225 (31.1)	1.250-28 UN-2A
21	1.3125-.1P-.2L-DS-2A	1.186 (30.1)	1.938 (49.2)	1.565 (39.8)	1.322 (33.6)		1.625 (41.3)	1.577 (40.1)	1.345 (34.2)	1.375-28 UN-2A

Dimensions in inches (millimeters) and are subject to change without notice.

240-801
Series 801 Mighty Mouse Filter Connector
High Density, Quick Coupling Threads



Mighty Mouse

Series 801 Mighty Mouse Square Flange Cut-Outs			
Shell Size	ØA	B Bsc	ØC Holes
5	.328 (8.33)	.363 (9.22)	.096 (2.44) .091 (2.31)
6	.390 (9.91)	.423 (10.74)	
7	.453 (11.51)	.483 (12.27)	
8	.515 (13.08)	.545 (13.84)	.130 (3.30) .126 (3.20)
9	.578 (14.68)	.607 (15.42)	
10	.640 (16.26)	.670 (17.02)	
11	.703 (17.86)	.715 (18.16)	
13	.828 (21.03)	.812 (20.62)	
16	1.015 (25.78)	.981 (24.92)	
17	1.078 (27.38)	1.060 (26.92)	
19	1.203 (30.56)	1.191 (30.25)	
21	1.328 (33.73)	1.322 (33.58)	

Square Flange Mount

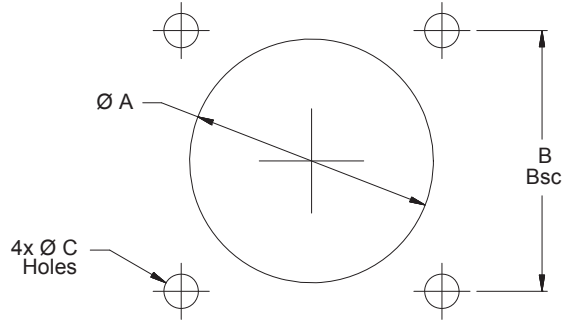

Jam Nut Mount

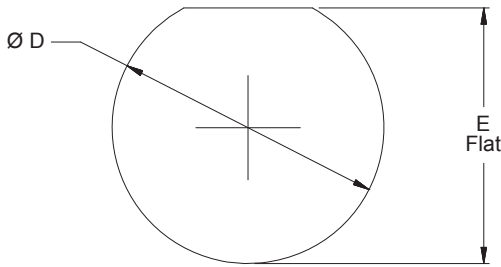

Series 801 Mighty Mouse Jam Nut Cut-Outs		
Shell Size	ØD	E Flat
5	.387 (9.8)	.358 (9.1)
	.383 (9.7)	.354 (9.0)
6	.449 (11.4)	.418 (10.6)
	.445 (11.3)	.414 (10.5)
7	.574 (14.6)	.544 (13.8)
	.570 (14.5)	.540 (13.7)
8	.574 (14.6)	.544 (13.8)
	.570 (14.5)	.540 (13.7)
9	.637 (16.2)	.604 (15.3)
	.633 (16.1)	.600 (15.2)
10	.699 (17.8)	.666 (16.9)
	.695 (17.7)	.662 (16.8)
11	.762 (19.4)	.726 (18.4)
	.758 (19.3)	.722 (18.3)
13	.887 (22.5)	.853 (21.7)
	.883 (22.4)	.849 (21.6)
16	1.077 (27.4)	1.030 (26.2)
	1.073 (27.3)	1.026 (26.1)
17	1.137 (28.9)	1.104 (28.0)
	1.133 (28.8)	1.100 (27.9)
19	1.262 (32.1)	1.235 (31.4)
	1.258 (32.0)	1.231 (31.3)
21	1.387 (35.2)	1.355 (34.4)
	1.383 (35.1)	1.351 (34.3)

Dimensions in inches (millimeters) and are subject to change without notice.

MIGHTY MOUSE FILTER CONNECTOR, DUAL-FLANGE WALL-MOUNT RECEPTACLE

How To Order									
Sample Part Number	240-801-	12	M	6-7	P	P	P	A	A
Filter Connector	Series 801 Mighty Mouse								
Shell Style	12 = Square flange receptacle with PCB contacts								
Shell Material/Finish	See Table I								
Insert Arrangement	See pages C-3 - C-7								
Contact Gender	P = Pin S = Socket								
Termination Type	P = PC Tail								
Filter Type	P = Pi Circuit C = C Circuit (See Note 1)								
Capacitance	See Table II								
Alternate Key Position	A, B, C, D, E, F, U A = Normal, U = Universal (See page C-2)								

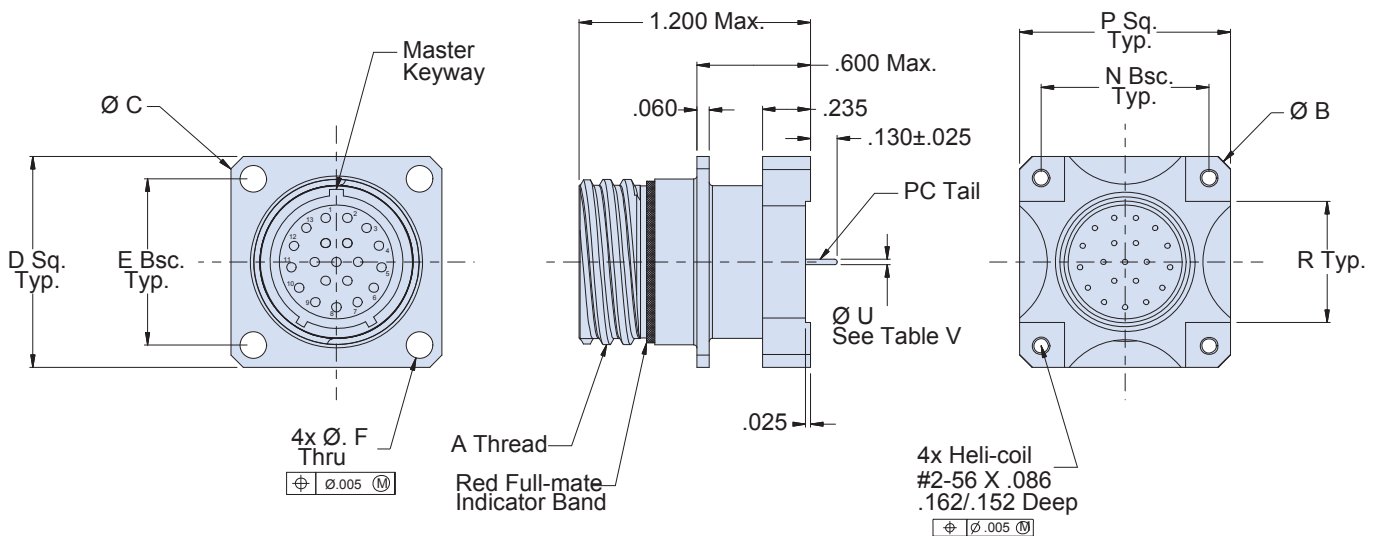

Notes

- Other filter styles (C-L, L-C, Unbalanced Pi, Multi-Stage, Multi-Value) are available, please consult the factory.

Dimensions in inches (millimeters) and are subject to change without notice.

240-801-12
Series 801 Mighty Mouse Filter Connector
 High Density, Quick Coupling Threads



Mighty Mouse

Table I: Connector Class		
Sym	Material	Finish Description
M	Aluminum	Electroless Nickel
MT		Ni-PTFE 1000 Hour Grey™ Nickel Fluorocarbon Polymer
NF		Cadmium, Olive Drab over Electroless Nickel
ZN		Zinc-Nickel, Olive Drab
ZR		Zinc-Nickel, Black - RoHS
ZL	Stainless Steel	Electro-Deposited Nickel

Table II: Capacitor Array Code Capacitance Range		
Class	Pi - Circuit (pF)	C - Circuit (pF)
A	38,000 - 56,000	19,000 - 28,000
B	32,000 - 45,000	16,000 - 22,500
C	18,000 - 33,000	9,000 - 16,500
D	8,000 - 12,000	4,000 - 6,000
E	3,300 - 5,000	1,650 - 2,500
F	800 - 1,300	400 - 650
G	400 - 600	200 - 300
J	70 - 120	35 - 60

Table V: PC Tail Dia	
Contact Size	Ø U
23	.022 (0.56)
	.018 (0.46)
20	.028 (0.71)
	.024 (0.61)
16	.042 (1.07)
	.038 (0.97)
12	.096 (2.44)
	.092 (2.34)

Table III: Dimensions									
Shell Size	A Thread	B Dia	C Dia	D Sq	E Bsc	F Holes	N Bsc	P Sq	R
5	.3125-.05P-.1L-DS-2A	.720 (18.3)	.680 (17.3)	.530 (13.5)	.363 (9.2)	.096 (2.4) .091 (2.3)	.363 (9.2)	.530 (13.5)	.143 (3.6)
6	.3750-.05P-.1L-DS-2A	.800 (20.3)	.750 (19.1)	.590 (15.0)	.423 (10.7)		.423 (10.7)	.590 (15.0)	.203 (5.2)
7	.4375-.05P-.1L-DS-2A	.900 (22.9)	.850 (21.6)	.650 (16.5)	.483 (12.3)		.483 (12.3)	.650 (16.5)	.263 (6.7)
8	.5000-.05P-.1L-DS-2A	.980 (24.9)	.938 (23.8)	.712 (18.1)	.545 (13.8)		.545 (13.8)	.712 (18.1)	.325 (8.3)
9	.5625-.05P-.1L-DS-2A	1.080 (27.4)	1.125 (28.6)	.850 (21.6)	.607 (15.4)		.607 (15.4)	.850 (21.6)	.387 (9.8)
10	.6250-.05P-.1L-DS-2A	1.160 (29.5)	1.188 (30.2)	.890 (22.6)	.670 (17.0)	.130 (3.3) .126 (3.2)	.670 (17.0)	.890 (22.6)	.450 (11.4)
11	.6875-.05P-.1L-DS-2A	1.220 (31.0)	1.250 (31.8)	.935 (23.7)	.715 (18.2)		.715 (18.2)	.935 (23.7)	.495 (12.6)
13	.8125-.1P-.2L-DS-2A	1.370 (34.8)	1.375 (34.9)	1.030 (26.2)	.812 (20.6)		.812 (20.6)	1.030 (26.2)	.592 (15.0)
16	1.000-.1P-.2L-DS-2A	1.620 (41.1)	1.625 (41.3)	1.219 (31.0)	.981 (24.9)		.981 (24.9)	1.219 (31.0)	.761 (19.3)
17	1.062-.1P-.2L-DS-2A	1.720 (43.7)	1.700 (43.2)	1.280 (32.5)	1.060 (26.9)		1.060 (26.9)	1.280 (32.5)	.840 (21.3)
19	1.1875-.1P-.2L-DS-2A	1.920 (48.8)	1.900 (48.3)	1.432 (36.4)	1.191 (30.3)		1.191 (30.3)	1.432 (36.4)	.971 (24.7)
21	1.3125-.1P-.2L-DS-2A	2.100 (53.3)	1.938 (49.2)	1.565 (39.8)	1.322 (33.6)		1.322 (33.6)	1.565 (39.8)	1.102 (28.0)

Dimensions in inches (millimeters) and are subject to change without notice.

MIGHTY MOUSE FILTER CONNECTOR, DUAL-FLANGE JAM NUT RECEPTACLE

How To Order	
Sample Part Number	240-801- 18 M 6-7 P P P A A
Filter Connector	Series 801 Mighty Mouse
Shell Style	18 = Jam Nut receptacle with PCB contacts
Shell Material/Finish	See Table I
Insert Arrangement	See pages C-3 - C-7
Contact Gender	P = Pin S = Socket
Termination Type	P = PC Tail
Filter Type	P = Pi Circuit C = C Circuit (See Note 1)
Capacitance	See Table II
Alternate Key Position	A, B, C, D, E, F, U A = Normal, U = Universal (See page C-2)

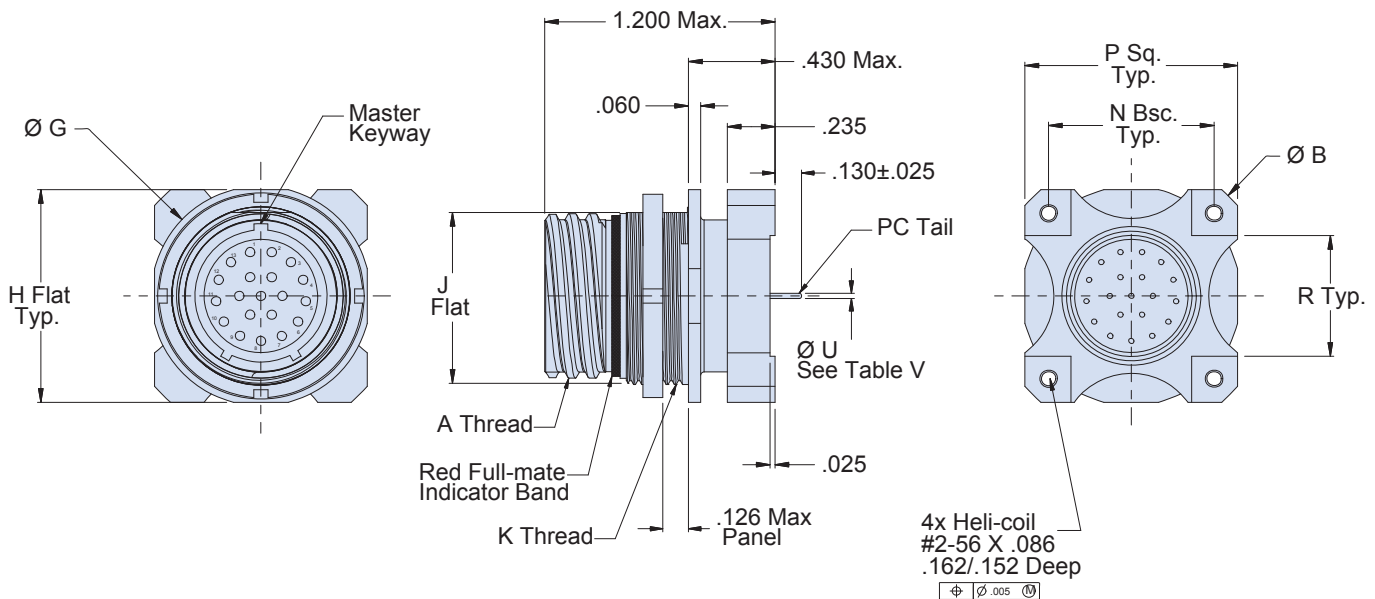

Notes

- Other filter styles (C-L, L-C, Unbalanced Pi, Multi-Stage, Multi-Value) are available, please consult the factory.

Dimensions in inches (millimeters) and are subject to change without notice.

240-801-18
Series 801 Mighty Mouse Filter Connector
 High Density, Quick Coupling Threads



Mighty Mouse

Table I: Connector Class

Sym	Material	Finish Description
M	Aluminum	Electroless Nickel
MT		Ni-PTFE 1000 Hour Grey™ Nickel Fluorocarbon Polymer
NF		Cadmium, Olive Drab over Electroless Nickel
ZN		Zinc-Nickel, Olive Drab
ZR		Zinc-Nickel, Black - RoHS
ZL	Stainless Steel	Electro-Deposited Nickel

Table II: Capacitor Array Code Capacitance Range

Class	Pi - Circuit (pF)	C - Circuit (pF)
A	38,000 - 56,000	19,000 - 28,000
B	32,000 - 45,000	16,000 - 22,500
C	18,000 - 33,000	9,000 - 16,500
D	8,000 - 12,000	4,000 - 6,000
E	3,300 - 5,000	1,650 - 2,500
F	800 - 1,300	400 - 650
G	400 - 600	200 - 300
J	70 - 120	35 - 60

**Table V:
PC Tail Dia**

Contact Size	Ø U
23	.022 (0.56)
	.018 (0.46)
20	.028 (0.71)
	.024 (0.61)
16	.042 (1.07)
	.038 (0.97)
12	.096 (2.44)
	.092 (2.34)

Table III: Dimensions

Shell Size	A Thread	B Dia	G Dia	H Flat	J Flat	K Thread	N Bsc	P Sq	R
5	.3125-.05P-.1L-DS-2A	.720 (18.3)	.575 (14.6)	.545 (13.8)	.350 (8.9)	.3750-28 UN-2A	.363 (9.2)	.530 (13.5)	.143 (3.6)
6	.3750-.05P-.1L-DS-2A	.800 (20.3)	.635 (16.1)	.595 (15.1)	.410 (10.4)	.4375-28 UNEF-2A	.423 (10.7)	.590 (15.0)	.203 (5.2)
7	.4375-.05P-.1L-DS-2A	.900 (22.9)	.755 (19.2)	.723 (18.4)	.536 (13.6)	.5625-32 UN-2A	.483 (12.3)	.650 (16.5)	.263 (6.7)
8	.5000-.05P-.1L-DS-2A	.980 (24.9)	.755 (19.2)	.723 (18.4)	.536 (13.6)	.5625-32 UN-2A	.545 (13.8)	.712 (18.1)	.325 (8.3)
9	.5625-.05P-.1L-DS-2A	1.080 (27.4)	.830 (21.1)	.790 (20.1)	.596 (15.1)	.6250-28 UN-2A	.607 (15.4)	.850 (21.6)	.387 (9.8)
10	.6250-.05P-.1L-DS-2A	1.160 (29.5)	.890 (22.6)	.855 (21.7)	.658 (16.7)	.6875-28 UN-2A	.670 (17.0)	.890 (22.6)	.450 (11.4)
11	.6875-.05P-.1L-DS-2A	1.220 (31.0)	.960 (24.4)	.925 (23.5)	.718 (18.2)	.750-28 UN-2A	.715 (18.2)	.935 (23.7)	.495 (12.6)
13	.8125-.1P-.2L-DS-2A	1.370 (34.8)	1.078 (27.4)	1.044 (26.5)	.845 (21.5)	.875-28 UN-2A	.812 (20.6)	1.030 (26.2)	.592 (15.0)
16	1.000-.1P-.2L-DS-2A	1.620 (41.1)	1.264 (32.1)	1.230 (31.2)	1.022 (26.0)	1.0625-20 UN-2A	.981 (24.9)	1.219 (31.0)	.761 (19.3)
17	1.062-.1P-.2L-DS-2A	1.720 (43.7)	1.325 (33.7)	1.290 (32.8)	1.096 (27.8)	1.125-28 UN-2A	1.060 (26.9)	1.280 (32.5)	.840 (21.3)
19	1.1875-.1P-.2L-DS-2A	1.920 (48.8)	1.450 (36.8)	1.415 (35.9)	1.225 (31.1)	1.250-28 UN-2A	1.191 (30.3)	1.432 (36.4)	.971 (24.7)
21	1.3125-.1P-.2L-DS-2A	2.100 (53.3)	1.625 (41.3)	1.577 (40.1)	1.345 (34.2)	1.375-28 UN-2A	1.322 (33.6)	1.565 (39.8)	1.102 (28.0)

Dimensions in inches (millimeters) and are subject to change without notice.

MIGHTY MOUSE FILTER CONNECTOR ADAPTER

How To Order								
Sample Part Number	240-801-	AA	M	6-7	PS	P	A	A
Filter Connector	Series 801 Mighty Mouse							
Shell Style	AA = Adapter							
Shell Material/Finish	See Table I							
Insert Arrangement	See pages C-3 – C-7							
Contact Gender	PS = Pins, Plug Side SP = Sockets, Plug Side (See Note 2)							
Filter Type	P = Pi Circuit C = C Circuit (See Note 1)							
Capacitance	See Table II							
Alternate Key Position	A, B, C, D, E, F, U A = Normal, U = Universal (See page C-2)							

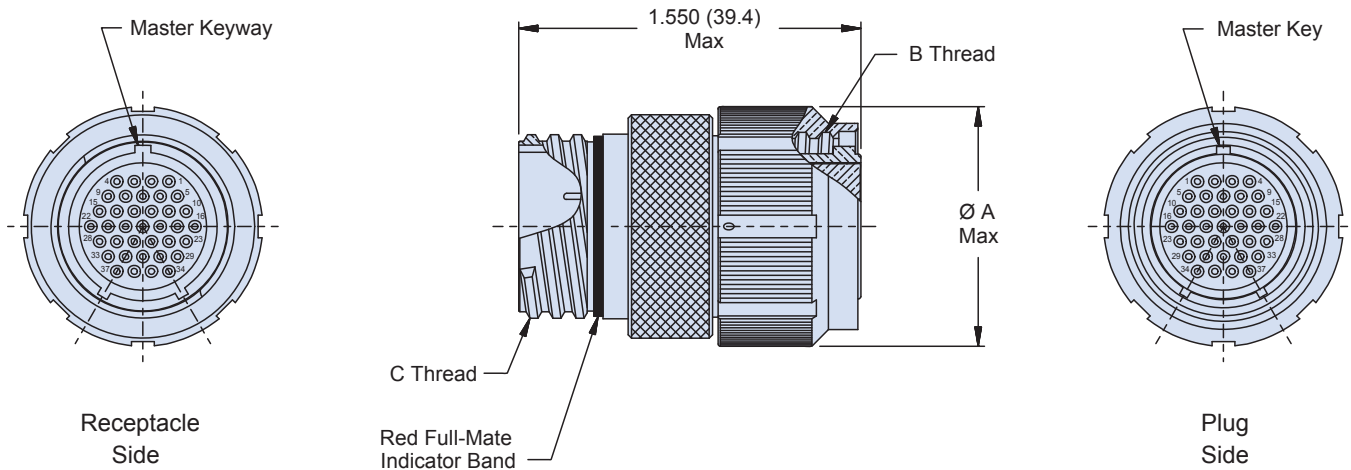

Notes

- Other filter styles (C-L, L-C, Unbalanced Pi, Multi-Stage, Multi-Value) are available, please consult the factory.
- Please consult factory for Pin/Pin and/or Socket/Socket contact arrangements.

Dimensions in inches (millimeters) and are subject to change without notice.

240-801-AA
Series 801 Mighty Mouse Filter Connector Adapter
High Density, Quick Coupling Threads



Table I: Connector Class		
Sym	Material	Finish Description
M	Aluminum	Electroless Nickel
MT		Ni-PTFE 1000 Hour Grey™ Nickel Fluorocarbon Polymer
NF		Cadmium, Olive Drab over Electroless Nickel
ZN		Zinc-Nickel, Olive Drab
ZR		Zinc-Nickel, Black - RoHS
ZL	Stainless Steel	Electro-Deposited Nickel

Table II: Capacitor Array Code Capacitance Range		
Class	Pi - Circuit (pF)	C - Circuit (pF)
A	38,000 - 56,000	19,000 - 28,000
B	32,000 - 45,000	16,000 - 22,500
C	18,000 - 33,000	9,000 - 16,500
D	8,000 - 12,000	4,000 - 6,000
E	3,300 - 5,000	1,650 - 2,500
F	800 - 1,300	400 - 650
G	400 - 600	200 - 300
J	70 - 120	35 - 60

Table III: Dimensions			
Shell Size	Ø A Max	B Thread	C Thread
5	.720 (18.3)	.3125-.05P-.1L-DS-2B	.3125-.05P-.1L-DS-2A
6	.800 (20.3)	.3750-.05P-.1L-DS-2B	.3750-.05P-.1L-DS-2A
7	.870 (22.1)	.4375-.05P-.1L-DS-2B	.4375-.05P-.1L-DS-2A
8	1.000 (25.4)	.5000-.05P-.1L-DS-2B	.5000-.05P-.1L-DS-2A
9	1.060 (26.9)	.5625-.05P-.1L-DS-2B	.5625-.05P-.1L-DS-2A
10	1.060 (26.9)	.6250-.05P-.1L-DS-2B	.6250-.05P-.1L-DS-2A
11	1.100 (27.9)	.6875-.05P-.1L-DS-2B	.6875-.05P-.1L-DS-2A
13	1.250 (31.8)	.8125-.1P-.2L-DS-2B	.8125-.1P-.2L-DS-2A
16	1.380 (35.1)	1.0000-.1P-.2L-DS-2B	1.0000-.1P-.2L-DS-2A
17	1.460 (37.1)	1.0625-.1P-.2L-DS-2B	1.0625-.1P-.2L-DS-2A
19	1.600 (40.6)	1.1875-.1P-.2L-DS-2B	1.1875-.1P-.2L-DS-2A
21	1.850 (47.0)	1.3125-.1P-.2L-DS-2B	1.3125-.1P-.2L-DS-2A

Dimensions in inches (millimeters) and are subject to change without notice.

240-804-07 and -08
Series 804 Mighty Mouse Filter Connector
Jam Nut Receptacle, Push-Pull Quick Disconnect



Mighty Mouse

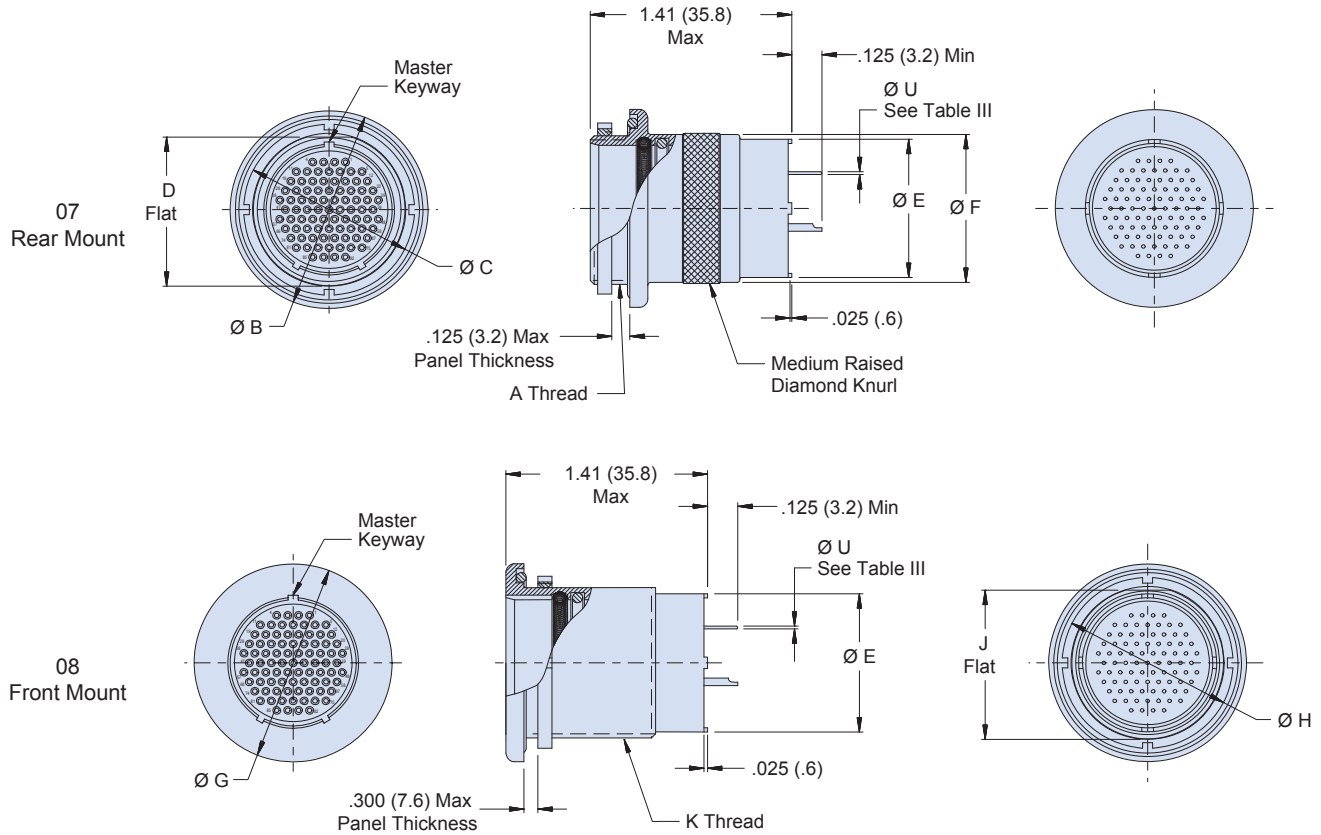

Table III: Dimensions

Shell Size	A Thread	Ø B	Ø C	D Flat	Ø E	Ø F	Ø G	Ø H	J Flat	K Thread	Rear Mount -07		Front Mount -08	
											M Flat	Ø N	P Flat	Ø R
5	.4375-32	.790	.562	.415	.365	.450	.830	.625	.470	.5000-32	.427 (10.9)	.453 (11.5)	.482 (12.2)	.515 (13.1)
	UN-2A	(20.1)	(14.3)	(10.5)	(9.3)	(11.4)	(21.1)	(15.9)	(11.9)	UN-2A	.423 (10.7)	.443 (11.3)	.478 (12.1)	.505 (12.8)
6	.5000-32	.830	.625	.467	.409	.520	.885	.688	.530	.5625-32	.479 (12.2)	.515 (13.1)	.542 (13.8)	.580 (14.7)
	UN-2A	(21.1)	(15.9)	(11.9)	(10.4)	(13.3)	(22.5)	(17.5)	(13.5)	UN-2A	.475 (12.1)	.505 (12.8)	.538 (13.7)	.570 (14.5)
7	.6250-28	.910	.750	.594	.500	.570	.995	.812	.663	.6875-28	.606 (15.4)	.640 (16.3)	.676 (17.2)	.703 (17.9)
	UN-2A	(23.1)	(19.1)	(15.1)	(12.7)	(14.5)	(25.3)	(20.6)	(16.8)	UN-2A	.602 (15.3)	.630 (16.0)	.671 (17.0)	.693 (17.6)
8	.6250-28	.955	.750	.594	.522	.603	.995	.812	.663	.6875-28	.606 (15.4)	.640 (16.3)	.676 (17.2)	.703 (17.9)
	UN-2A	(24.3)	(19.1)	(15.1)	(13.3)	(15.3)	(25.3)	(20.6)	(16.8)	UN-2A	.602 (15.3)	.630 (16.0)	.671 (17.0)	.693 (17.6)
9	.6875-28	1.000	.812	.655	.610	.685	1.075	.875	.720	.7500-28	.667 (17.0)	.700 (17.8)	.732 (18.6)	.765 (19.4)
	UN-2A	(25.4)	(20.6)	(16.6)	(15.5)	(17.4)	(27.3)	(22.2)	(18.3)	UN-2A	.663 (16.8)	.690 (17.5)	.728 (18.5)	.755 (19.2)
10	.7500-28	1.085	.875	.721	.652	.735	1.140	.938	.788	.8125-28	.734 (18.6)	.765 (19.4)	.801 (20.4)	.827 (21.0)
	UN-2A	(27.6)	(22.2)	(18.3)	(16.6)	(18.7)	(29.0)	(23.8)	(20.0)	UN-2A	.729 (18.5)	.755 (19.2)	.796 (20.2)	.817 (20.8)
11	.8125-28	1.135	.938	.788	.694	.810	1.190	1.000	.843	.8750-28	.801 (20.3)	.827 (21.0)	.855 (21.7)	.890 (22.6)
	UN-2A	(28.8)	(23.8)	(20.0)	(17.6)	(20.6)	(30.2)	(25.4)	(21.4)	UN-2A	.796 (20.2)	.817 (20.8)	.851 (21.6)	.880 (22.4)
12	.8750-28	1.180	1.000	.843	.746	.850	1.340	1.125	.970	1.0000-28	.855 (21.7)	.890 (22.6)	.982 (24.9)	1.015 (25.8)
	UN-2A	(30.0)	(25.4)	(21.4)	(18.9)	(21.6)	(34.0)	(28.6)	(24.6)	UN-2A	.851 (21.6)	.880 (22.4)	.978 (24.8)	1.005 (25.5)
14	1.0000-28	1.325	1.125	.968	.871	.973	1.390	1.188	1.020	1.0625-20	.980 (24.9)	1.015 (25.8)	1.032 (26.2)	1.080 (27.4)
	UN-2A	(33.7)	(28.6)	(24.6)	(22.1)	(24.7)	(35.3)	(30.2)	(25.9)	UN-2A	.976 (24.8)	1.005 (25.5)	1.028 (26.1)	1.070 (27.2)
15	1.0625-20	1.390	1.188	1.029	.965	1.060	1.450	1.250	1.104	1.1250-28	1.041 (26.4)	1.075 (27.3)	1.015 (25.8)	1.140 (29.0)
	UN-2A	(35.3)	(30.2)	(26.1)	(24.5)	(26.9)	(36.8)	(31.8)	(28.0)	UN-2A	1.037 (26.3)	1.065 (27.1)	1.011 (25.7)	1.130 (28.7)

Dimensions in inches (millimeters) and are subject to change without notice.

© 2013 Glenair, Inc.

EMI/EMP Filter Connectors

U.S. CAGE Code 06324

Rev. 06.02.15

Printed in U.S.A.



240-805

Series 805 Mighty Mouse Filter Connector Receptacles with Triple-Start ACME Coupling Threads, Solder Cup Contacts and Banding Platform

MIGHTY MOUSE TRIPLE-START RECEPTACLE FILTER CONNECTOR WITH SOLDER CUP CONTACTS AND BANDING PLATFORM

How To Order	
Sample Part Number	240-805- 07 M 8-7 P S P A A
Filter Connector	Series 805 Mighty Mouse Triple-Start
Shell Style	01 = Square flange receptacle with solder cup contacts and banding platform 07 = Jam nut receptacle with solder cup contacts and banding platform
Shell Material/Finish	See Table I
Insert Arrangement	See pages C-3 – C-7
Contact Gender	P = Pin S = Socket
Termination Type	S = Solder Cup
Filter Type	P = Pi Circuit C = C Circuit (See Note 1)
Capacitance	See Table II
Alternate Key Position	A, B, C, D, E, F, U A = Normal, U = Universal (See page C-2)

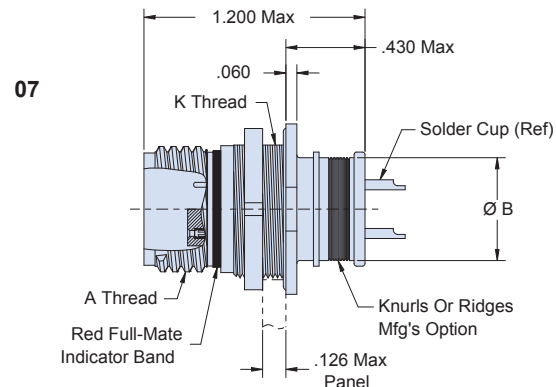
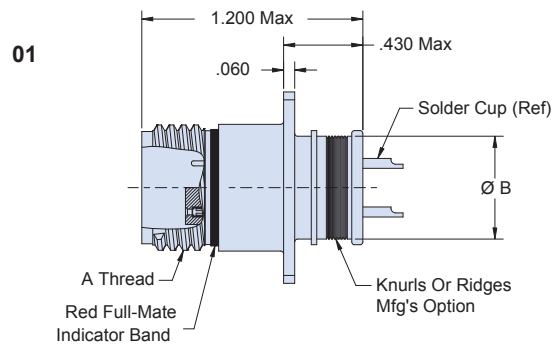
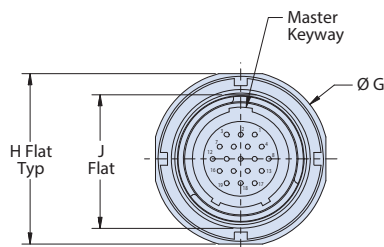
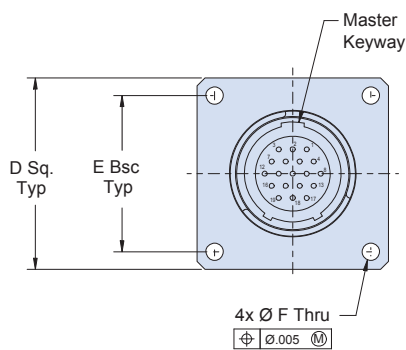

Notes

- Other filter styles (C-L, L-C, Unbalanced Pi, Multi-Stage, Multi-Value) are available, please consult the factory.

Dimensions in inches (millimeters) and are subject to change without notice.

240-805

**Series 805 Mighty Mouse Filter Connector
Receptacles with Triple-Start ACME Coupling Threads,
PCB Contacts**



Mighty Mouse

C

MIGHTY MOUSE TRIPLE-START RECEPTACLE FILTER CONNECTOR WITH PCB CONTACTS

How To Order	
Sample Part Number	240-805- 02 M 8-7 P P P A A
Filter Connector	Series 805 Mighty Mouse Triple-Start
Shell Style	02 = Square flange receptacle with PCB contacts 08 = Jam nut receptacle with with PCB contacts
Shell Material/Finish	See Table I
Insert Arrangement	See pages C-3 – C-7
Contact Gender	P = Pin S = Socket
Termination Type	P = PC Tail
Filter Type	P = Pi Circuit C = C Circuit (See Note 1)
Capacitance	See Table II
Alternate Key Position	A, B, C, D, E, F, U A = Normal, U = Universal (See page C-2)

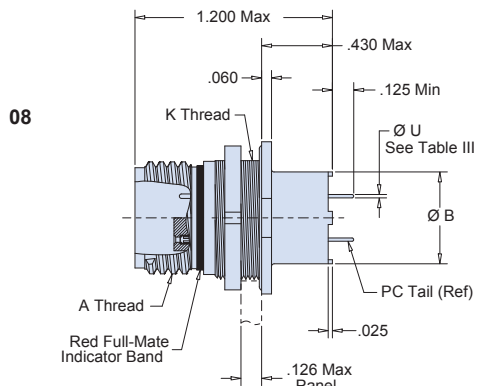
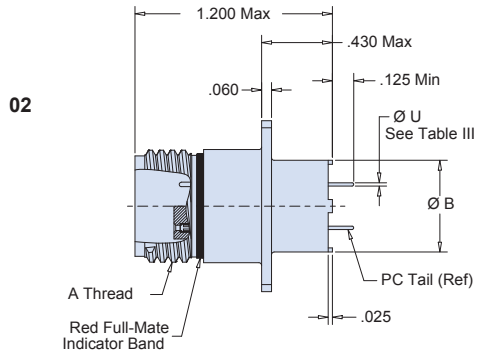
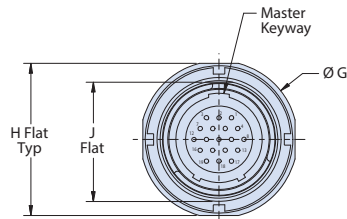
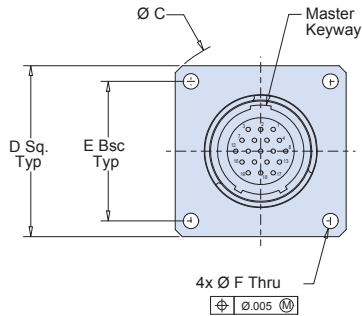

Notes

1. Other filter styles (C-L, L-C, Unbalanced Pi, Multi-Stage, Multi-Value) are available, please consult the factory.

Dimensions in inches (millimeters) and are subject to change without notice.



240-805

Series 805 Mighty Mouse Filter Connector Receptacles with Triple-Start ACME Coupling Threads

Table I: Connector Class

Sym	Material	Finish Description
M	Aluminum	Electroless Nickel
MT		Ni-PTFE 1000 Hour Grey™ Nickel Fluorocarbon Polymer
NF		Cadmium, Olive Drab over Electroless Nickel
ZN		Zinc-Nickel, Olive Drab
ZR		Zinc-Nickel, Black - RoHS
ZL	Stainless Steel	Electro-Deposited Nickel

Table II: Capacitor Array Code Capacitance Range

Class	Pi - Circuit (pF)	C - Circuit (pF)
A	38,000 - 56,000	19,000 - 28,000
B	32,000 - 45,000	16,000 - 22,500
C	18,000 - 33,000	9,000 - 16,500
D	8,000 - 12,000	4,000 - 6,000
E	3,300 - 5,000	1,650 - 2,500
F	800 - 1,300	400 - 650
G	400 - 600	200 - 300
J	70 - 120	35 - 60

Table IV:
PC Tail Dia

Contact Size	Ø U
23	.022 (0.56)
	.018 (0.46)
20	.028 (0.71)
	.024 (0.61)
16	.042 (1.07)
	.038 (0.97)
12	.096 (2.44)
	.092 (2.34)

Table III: Dimensions

Shell Size	A Thread	B Dia	C Dia	D Sq	E Bsc	F Holes	G Dia	H Flat	J Flat	K Thread
8	.5000-.1P-.3L-TS-2A	.413 (10.5)	1.150 (29.2)	.850 (21.6)	.660 (16.8)	.096 (2.4) .091 (2.3)	.760 (19.3)	.730 (18.5)	.535 (13.6)	.5625-28 UN-2A
9	.5625-.1P-.3L-TS-2A	.500 (12.7)	1.230 (31.2)	.913 (23.2)	.723 (18.4)		.880 (22.4)	.850 (21.6)	.661 (16.8)	.6875-28 UN-2A
10	.6250-.1P-.3L-TS-2A	.530 (13.5)	1.330 (33.7)	.975 (24.8)	.785 (19.9)		.880 (22.4)	.850 (21.6)	.661 (16.8)	.6875-28 UN-2A
11	.6875-.1P-.3L-TS-2A	.610 (15.5)	1.410 (35.8)	1.039 (26.4)	.848 (21.5)		.955 (24.3)	.925 (23.5)	.721 (18.3)	.7500-28 UN-2A
12	.7500-.1P-.3L-TS-2A	.655 (16.6)	1.500 (38.1)	1.099 (27.9)	.909 (23.1)		1.060 (26.9)	1.035 (26.3)	.784 (19.9)	.8125-28 UN-2A
13	.8125-.1P-.3L-TS-2A	.685 (17.4)	1.590 (40.4)	1.163 (29.5)	.973 (24.7)	.130 (3.3) .126 (3.2)	1.120 (28.4)	1.090 (27.7)	.843 (21.4)	.8750-28 UN-2A
15	.9375-.1P-.3L-TS-2A	.746 (18.9)	1.750 (44.5)	1.288 (32.7)	1.058 (26.9)		1.203 (30.6)	1.173 (29.8)	.970 (24.6)	1.000-28 UN-2A
18	1.1250-.1P-.3L-TS-2A	.871 (22.1)	2.000 (50.8)	1.475 (37.5)	1.255 (31.9)		1.389 (35.3)	1.359 (34.5)	1.147 (29.1)	1.187-28 UN-2A
19	1.1870-.1P-.3L-TS-2A	.972 (24.7)	2.094 (53.2)	1.537 (39.0)	1.327 (33.7)		1.450 (36.8)	1.420 (36.1)	1.221 (31.0)	1.250-28 UN-2A
21	1.3125-.1P-.3L-TS-2A	1.084 (27.5)	2.270 (57.7)	1.663 (42.2)	1.452 (36.9)		1.590 (40.4)	1.560 (39.6)	1.350 (34.3)	1.3750-28 UN-2A
23	1.4375-.1P-.3L-TS-2A	1.186 (30.1)	2.440 (62.0)	1.787 (45.4)	1.570 (39.9)	1.705 (43.3)	1.675 (42.5)	1.470 (37.3)	1.500-28 UN-2A	

Dimensions in inches (millimeters) and are subject to change without notice.

240-805

**Series 805 Mighty Mouse Filter Connector
Receptacles with Triple-Start ACME Coupling Threads**



Mighty Mouse

Series 805 Mighty Mouse Square Flange Cut-Outs

Shell Size	ØA	B Bsc	ØC Holes
8	.515 (13.08)	.660 (16.76)	.096 (2.4) .091 (2.3)
9	.578 (14.68)	.723 (18.36)	
10	.640 (16.26)	.785 (19.94)	
11	.703 (17.86)	.848 (21.54)	
12	.765 (19.43)	.909 (23.09)	
13	.828 (21.03)	.973 (24.71)	
15	.953 (24.21)	1.058 (26.87)	.130 (3.3) .126 (3.2)
18	1.140 (28.96)	1.255 (31.88)	
19	1.203 (30.56)	1.327 (33.71)	
21	1.328 (33.73)	1.452 (36.88)	
23	1.453 (36.91)	1.570 (39.88)	

Square Flange Mount

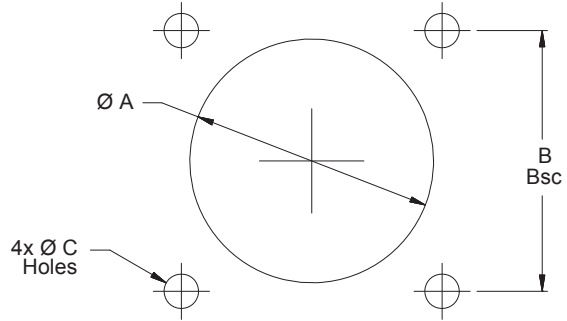

Jam Nut Mount

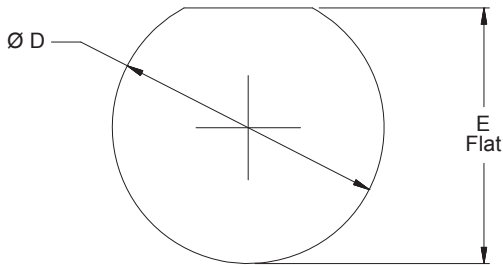

**Series 805 Mighty Mouse
Jam Nut Cut-Outs**

Shell Size	ØD	E Flat
8	.575 (14.6)	.547 (13.9)
	.571 (14.5)	.543 (13.8)
9	.700 (17.8)	.673 (17.1)
	.696 (17.7)	.669 (17.0)
10	.700 (17.8)	.673 (17.1)
	.696 (17.7)	.669 (17.0)
11	.762 (19.4)	.733 (18.6)
	.758 (19.3)	.729 (18.5)
12	.825 (21.0)	.796 (20.2)
	.821 (20.9)	.792 (20.1)
13	.887 (22.5)	.853 (21.7)
	.883 (22.4)	.849 (21.6)
15	1.012 (25.7)	.982 (24.9)
	1.008 (25.6)	.978 (24.8)
18	1.200 (30.5)	1.159 (29.4)
	1.196 (30.4)	1.155 (29.3)
19	1.262 (32.1)	1.233 (31.3)
	1.258 (32.0)	1.229 (31.2)
21	1.387 (35.2)	1.360 (34.5)
	1.383 (35.1)	1.356 (34.4)
23	1.512 (38.4)	1.482 (37.6)
	1.508 (38.3)	1.478 (37.5)

Dimensions in inches (millimeters) and are subject to change without notice.



240-805-12
 Series 805 Mighty Mouse Filter Connector
 Receptacles with Triple-Start ACME Coupling Threads

MIGHTY MOUSE FILTER CONNECTOR, DUAL-FLANGE WALL-MOUNT RECEPTACLE

How To Order									
Sample Part Number	240-805-	12	M	8-7	P	P	P	A	A
Filter Connector	Series 805 Mighty Mouse								
Shell Style	12 = Square flange receptacle with PCB contacts								
Shell Material/Finish	See Table I								
Insert Arrangement	See pages C-3 - C-7								
Contact Gender	P = Pin S = Socket								
Termination Type	P = PC Tail								
Filter Type	P = Pi Circuit C = C Circuit (See Note 1)								
Capacitance	See Table II								
Alternate Key Position	A, B, C, D, E, F, U A = Normal, U = Universal (See page C-2)								

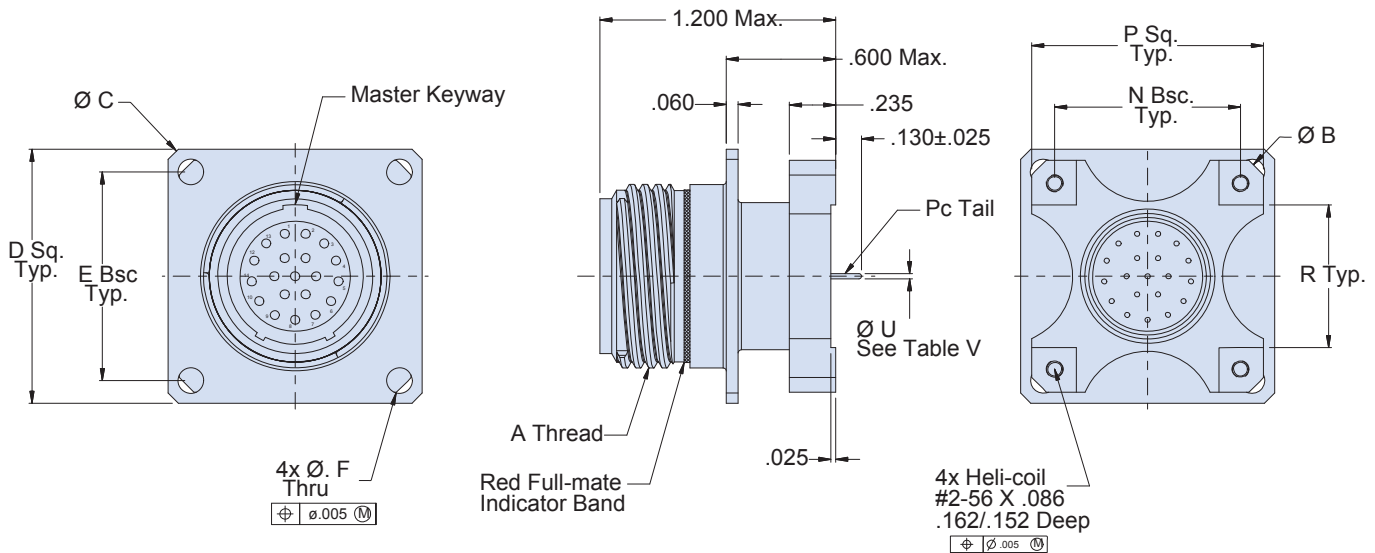

Notes

- Other filter styles (C-L, L-C, Unbalanced Pi, Multi-Stage, Multi-Value) are available, please consult the factory.

Dimensions in inches (millimeters) and are subject to change without notice.

240-805-12
Series 805 Mighty Mouse Filter Connector
Receptacles with Triple-Start ACME Coupling Threads



Table I: Connector Class

Sym	Material	Finish Description
M	Aluminum	Electroless Nickel
MT		Ni-PTFE 1000 Hour Grey™ Nickel Fluorocarbon Polymer
NF		Cadmium, Olive Drab over Electroless Nickel
ZN		Zinc-Nickel, Olive Drab
ZR		Zinc-Nickel, Black - RoHS
ZL	Stainless Steel	Electro-Deposited Nickel

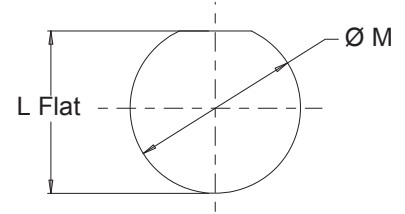

Table II: Capacitor Array Code Capacitance Range

Class	Pi - Circuit (pF)	C - Circuit (pF)
A	38,000 - 56,000	19,000 - 28,000
B	32,000 - 45,000	16,000 - 22,500
C	18,000 - 33,000	9,000 - 16,500
D	8,000 - 12,000	4,000 - 6,000
E	3,300 - 5,000	1,650 - 2,500
F	800 - 1,300	400 - 650
G	400 - 600	200 - 300
J	70 - 120	35 - 60

Recommended Panel Cut-Out

Shell Size	ØM	L Flat
5	.387 (9.8)	.358 (9.1)
	.383 (9.7)	.354 (9.0)
6	.449 (11.4)	.418 (10.6)
	.445 (11.3)	.414 (10.5)
7	.574 (14.6)	.544 (13.8)
	.570 (14.5)	.540 (13.7)
8	.574 (14.6)	.544 (13.8)
	.570 (14.5)	.540 (13.7)
9	.637 (16.2)	.604 (15.3)
	.633 (16.1)	.600 (15.2)
10	.699 (17.8)	.666 (16.9)
	.695 (17.7)	.662 (16.8)
11	.762 (19.4)	.726 (18.4)
	.758 (19.3)	.722 (18.3)
13	.887 (22.5)	.853 (21.7)
	.883 (22.4)	.849 (21.6)
16	1.077 (27.4)	1.030 (26.2)
	1.073 (27.3)	1.026 (26.1)
17	1.137 (28.9)	1.104 (28.0)
	1.133 (28.8)	1.100 (27.9)
19	1.262 (32.1)	1.235 (31.4)
	1.258 (32.0)	1.231 (31.3)
21	1.387 (35.2)	1.355 (34.4)
	1.383 (35.1)	1.351 (34.3)

**Table V:
PC Tail Dia**

Contact Size	Ø U
23	.022 (0.56)
	.018 (0.46)
20	.028 (0.71)
	.024 (0.61)
16	.042 (1.07)
	.038 (0.97)
12	.096 (2.44)
	.092 (2.34)

Table III: Dimensions

Shell Size	A Thread	B Dia	C Dia	D Sq	E Bsc	F Holes	N Bsc	P Sq	R
8	.5000-1P-.3L-TS-2A	.800 (20.3)	1.150 (29.2)	.850 (21.6)	.660 (16.8)	.096 (2.4) .091 (2.3)	.423 (10.7)	.590 (15.0)	.203 (5.2)
9	.5625-1P-.3L-TS-2A	.900 (22.9)	1.230 (31.2)	.913 (23.2)	.723 (18.4)		.483 (12.3)	.650 (16.5)	.263 (6.7)
10	.6250-1P-.3L-TS-2A	.980 (24.9)	1.330 (33.7)	.975 (24.8)	.785 (19.9)		.545 (13.8)	.712 (18.1)	.325 (8.3)
11	.6875-1P-.3L-TS-2A	1.080 (27.4)	1.410 (35.8)	1.039 (26.4)	.848 (21.5)		.607 (15.4)	.850 (21.6)	.387 (9.8)
12	.7500-1P-.3L-TS-2A	1.160 (29.5)	1.500 (38.1)	1.099 (27.9)	.909 (23.1)		.670 (17.0)	.890 (22.6)	.450 (11.4)
13	.8125-1P-.3L-TS-2A	1.220 (31.0)	1.590 (40.4)	1.163 (29.5)	.973 (24.7)		.715 (18.2)	.935 (23.7)	.495 (12.6)
15	.9375-1P-.3L-TS-2A	1.370 (34.8)	1.750 (44.5)	1.288 (32.7)	1.058 (26.9)	.130 (3.3) .126 (3.2)	.812 (20.6)	1.030 (26.2)	.592 (15.0)
18	1.1250-1P-.3L-TS-2A	1.620 (41.1)	2.000 (50.8)	1.475 (37.5)	1.255 (31.9)		.981 (24.9)	1.219 (31.0)	.761 (19.3)
19	1.1870-1P-.3L-TS-2A	1.720 (43.7)	2.094 (53.2)	1.537 (39.0)	1.327 (33.7)		1.060 (26.9)	1.280 (32.5)	.840 (21.3)
21	1.3125-1P-.3L-TS-2A	1.920 (48.8)	2.270 (57.7)	1.663 (42.2)	1.452 (36.9)		1.191 (30.3)	1.432 (36.4)	.971 (24.7)
23	1.4375-1P-.3L-TS-2A	2.100 (53.3)	2.440 (62.0)	1.787 (45.4)	1.570 (39.9)		1.322 (33.6)	1.565 (39.8)	1.102 (28.0)

Dimensions in inches (millimeters) and are subject to change without notice.

MIGHTY MOUSE FILTER CONNECTOR, DUAL-FLANGE JAM NUT RECEPTACLE

How To Order	
Sample Part Number	240-805- 18 M 8-7 P P P A A
Filter Connector	Series 805 Mighty Mouse
Shell Style	18 = Jam nut receptacle with PCB contacts
Shell Material/Finish	See Table I
Insert Arrangement	See pages C-3 - C-7
Contact Gender	P = Pin S = Socket
Termination Type	P = PC Tail
Filter Type	P = Pi Circuit C = C Circuit (See Note 1)
Capacitance	See Table II
Alternate Key Position	A, B, C, D, E, F, U A = Normal, U = Universal (See page C-2)

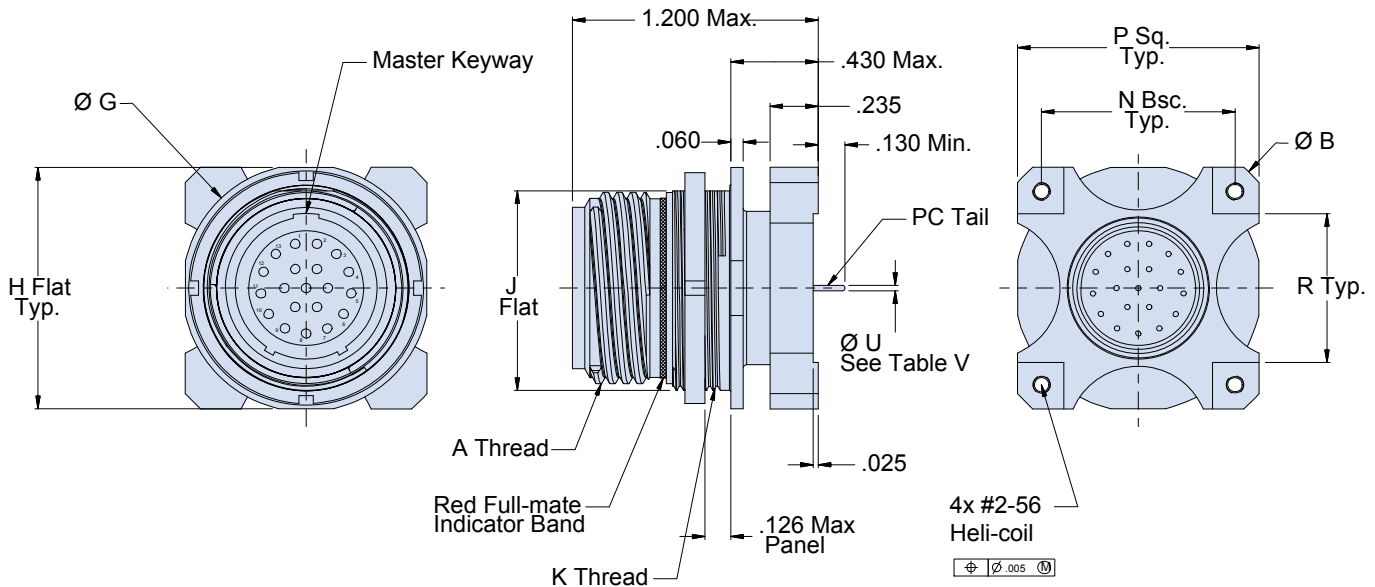

Notes

- Other filter styles (C-L, L-C, Unbalanced Pi, Multi-Stage, Multi-Value) are available, please consult the factory.

Dimensions in inches (millimeters) and are subject to change without notice.

240-805-18
Series 805 Mighty Mouse Filter Connector
Receptacles with Triple-Start ACME Coupling Threads



Table I: Connector Class

Sym	Material	Finish Description
M	Aluminum	Electroless Nickel
MT		Ni-PTFE 1000 Hour Grey™ Nickel Fluorocarbon Polymer
NF		Cadmium, Olive Drab over Electroless Nickel
ZN		Zinc-Nickel, Olive Drab
ZR		Zinc-Nickel, Black - RoHS
ZL	Stainless Steel	Electro-Deposited Nickel

Table II: Capacitor Array Code Capacitance Range

Class	Pi - Circuit (pF)	C - Circuit (pF)
A	38,000 - 56,000	19,000 - 28,000
B	32,000 - 45,000	16,000 - 22,500
C	18,000 - 33,000	9,000 - 16,500
D	8,000 - 12,000	4,000 - 6,000
E	3,300 - 5,000	1,650 - 2,500
F	800 - 1,300	400 - 650
G	400 - 600	200 - 300
J	70 - 120	35 - 60

**Table V:
PC Tail Dia**

Contact Size	Ø U
23	.022 (0.56)
	.018 (0.46)
20	.028 (0.71)
	.024 (0.61)
16	.042 (1.07)
	.038 (0.97)
12	.096 (2.44)
	.092 (2.34)

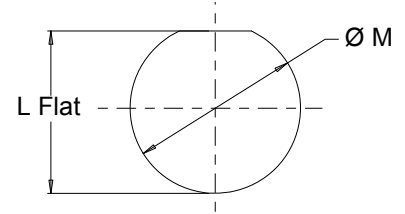

Recommended Panel Cut-Out

Shell Size	L Flat	Ø M
8	.547 (13.89)	.575 (14.60)
	.543 (13.79)	.571 (14.50)
9	.673 (17.09)	.700 (17.78)
	.669 (16.99)	.696 (17.68)
10	.673 (17.09)	.700 (17.78)
	.669 (16.99)	.696 (17.68)
11	.733 (18.62)	.762 (19.35)
	.729 (18.52)	.758 (19.25)
12	.796 (20.22)	.825 (20.96)
	.792 (20.12)	.821 (20.85)
13	.853 (21.67)	.887 (22.53)
	.849 (21.56)	.883 (22.43)
15	.982 (24.94)	1.012 (25.70)
	.978 (24.84)	1.008 (25.60)
18	1.159 (29.44)	1.200 (30.48)
	1.155 (29.34)	1.196 (30.38)
19	1.233 (31.32)	1.262 (32.05)
	1.229 (31.22)	1.258 (31.95)
21	1.360 (34.54)	1.387 (35.23)
	1.356 (34.44)	1.383 (35.13)
23	1.482 (37.64)	1.512 (38.40)
	1.478 (37.54)	1.508 (38.30)

Table III: Dimensions

Shell Size	A Thread	B Dia	G Dia	H Flat	J Flat	K Thread	N Bsc	P Sq	R
8	.5000-1P-.3L-TS-2A	.920 (23.37)	.760 (19.3)	.730 (18.5)	.535 (13.6)	.5625-28 UN-2A	.496 (12.60)	.728 (18.49)	.276 (7.01)
9	.5625-1P-.3L-TS-2A	1.110 (28.19)	.880 (22.4)	.850 (21.6)	.661 (16.8)	.6875-28 UN-2A	.627 (15.93)	.859 (21.82)	.407 (10.34)
10	.6250-1P-.3L-TS-2A	1.110 (28.19)	.880 (22.4)	.850 (21.6)	.661 (16.8)	.6875-28 UN-2A	.627 (15.93)	.859 (21.82)	.407 (10.34)
11	.6875-1P-.3L-TS-2A	1.200 (30.48)	.955 (24.3)	.925 (23.5)	.721 (18.3)	.7500-28 UN-2A	.698 (17.73)	.930 (23.62)	.478 (12.14)
12	.7500-1P-.3L-TS-2A	1.370 (34.80)	1.060 (26.9)	1.035 (26.3)	.784 (19.9)	.8125-28 UN-2A	.812 (20.62)	1.044 (26.52)	.592 (15.04)
13	.8125-1P-.3L-TS-2A	1.420 (36.07)	1.120 (28.4)	1.090 (27.7)	.843 (21.4)	.8750-28 UN-2A	.853 (21.67)	1.085 (27.56)	.633 (16.08)
15	.9375-1P-.3L-TS-2A	1.560 (39.62)	1.203 (30.6)	1.173 (29.8)	.970 (24.6)	1.000-28 UN-2A	.943 (23.95)	1.175 (29.85)	.723 (18.36)
18	1.1250-1P-.3L-TS-2A	1.800 (45.72)	1.389 (35.3)	1.359 (34.5)	1.147 (29.1)	1.187-28 UN-2A	1.119 (28.42)	1.351 (34.32)	.899 (22.83)
19	1.1870-1P-.3L-TS-2A	1.880 (47.75)	1.450 (36.8)	1.420 (36.1)	1.221 (31.0)	1.250-28 UN-2A	1.175 (29.85)	1.407 (35.74)	.955 (24.26)
21	1.3125-1P-.3L-TS-2A	2.090 (53.09)	1.590 (40.4)	1.560 (39.6)	1.350 (34.3)	1.3750-28 UN-2A	1.318 (33.48)	1.550 (39.37)	1.098 (27.89)
23	1.4375-1P-.3L-TS-2A	2.270 (57.66)	1.705 (43.3)	1.675 (42.5)	1.470 (37.3)	1.500-28 UN-2A	1.448 (36.78)	1.680 (42.67)	1.228 (31.19)

Dimensions in inches (millimeters) and are subject to change without notice.

MIGHTY MOUSE TRIPLE-START CONNECTOR ADAPTER

How To Order	
Sample Part Number	240-805-AA M 8-7 PS P A A
Filter Connector	Series 805 Mighty Mouse Triple-Start
Shell Style	AA = Adapter
Shell Material/Finish	See Table I
Insert Arrangement	See pages C-3 – C-7
Contact Gender	PS = Pins, Plug Side SP = Sockets, Plug Side (See Note 2)
Filter Type	P = Pi Circuit C = C Circuit (See Note 1)
Capacitance	See Table II
Alternate Key Position	A, B, C, D, E, F, U A = Normal, U = Universal (See page C-2)

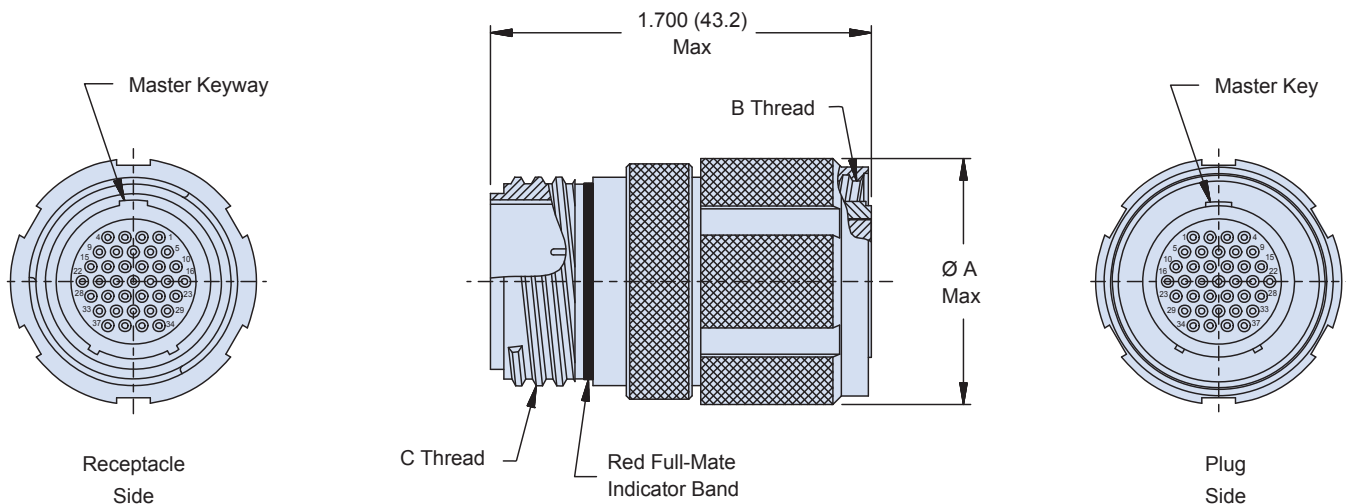

Notes

- Other filter styles (C-L, L-C, Unbalanced Pi, Multi-Stage, Multi-Value) are available, please consult the factory.
- Please consult factory for Pin/Pin and/or Socket/Socket contact arrangements.

Dimensions in inches (millimeters) and are subject to change without notice.

240-805-AA
Series 805 Mighty Mouse Filter Connector
Adapter with Triple-Start ACME Coupling Threadst



Table I: Connector Class		
Sym	Material	Finish Description
M	Aluminum	Electroless Nickel
MT		Ni-PTFE 1000 Hour Grey™ Nickel Fluorocarbon Polymer
NF		Cadmium, Olive Drab over Electroless Nickel
ZN		Zinc-Nickel, Olive Drab
ZR		Zinc-Nickel, Black - RoHS
ZL	Stainless Steel	Electro-Deposited Nickel

Table II: Capacitor Array Code Capacitance Range		
Class	Pi - Circuit (pF)	C - Circuit (pF)
A	38,000 - 56,000	19,000 - 28,000
B	32,000 - 45,000	16,000 - 22,500
C	18,000 - 33,000	9,000 - 16,500
D	8,000 - 12,000	4,000 - 6,000
E	3,300 - 5,000	1,650 - 2,500
F	800 - 1,300	400 - 650
G	400 - 600	200 - 300
J	70 - 120	35 - 60

Table III: Dimensions			
Shell Size	Ø A Max	B Thread	C Thread
8	.870 (22.1)	.5000-.1P-.3L-TS-2B	.5000-.1P-.3L-TS-2A
9	.930 (23.6)	.5625-.1P-.3L-TS-2B	.5625-.1P-.3L-TS-2A
10	1.000 (25.4)	.6250-.1P-.3L-TS-2B	.6250-.1P-.3L-TS-2A
11	1.170 (29.7)	.6875-.1P-.3L-TS-2B	.6875-.1P-.3L-TS-2A
12	1.170 (29.7)	.7500-.1P-.3L-TS-2B	.7500-.1P-.3L-TS-2A
13	1.300 (33.0)	.8125-.1P-.3L-TS-2B	.8125-.1P-.3L-TS-2A
15	1.350 (34.3)	.9375-.1P-.3L-TS-2B	.9375-.1P-.3L-TS-2A
18	1.600 (40.6)	1.1250-.1P-.3L-TS-2B	1.1250-.1P-.3L-TS-2A
19	1.600 (40.6)	1.1875-.1P-.3L-TS-2B	1.1875-.1P-.3L-TS-2A
21	1.750 (44.5)	1.3125-.1P-.3L-TS-2B	1.3125-.1P-.3L-TS-2A
23	1.850 (47.0)	1.4375-.1P-.3L-TS-2B	1.4375-.1P-.3L-TS-2A

Dimensions in inches (millimeters) and are subject to change without notice.

MIGHTY MOUSE UN THREADED RECEPTACLE, SQUARE FLANGE OR JAM NUT

		How To Order							
Sample Part Number	240-800-	02	M	6-7	P	S	P	A	N
Filter Connector	Series 800 Mighty Mouse								
Shell Style	01 = Square flange receptacle with solder cup contacts and banding platform		07 = Jam nut receptacle with solder cup contacts and banding platform						
	02 = Square flange receptacle with PCB contacts		08 = Jam nut receptacle with PCB contacts						
Shell Material/Finish	See Table II								
Insert Arrangement	See page C-23								
Contact Gender	P = Pin S = Socket								
Termination	P = PC Tail (shell styles 02 and 08 only) S = Solder Cup (shell styles 01 and 07 only)								
Filter Type	P = Pi Circuit C = C Circuit (See Note 1)								
Capacitance	See Table III								
Alternate Keyway Position	X, Y, Z, N = Normal								

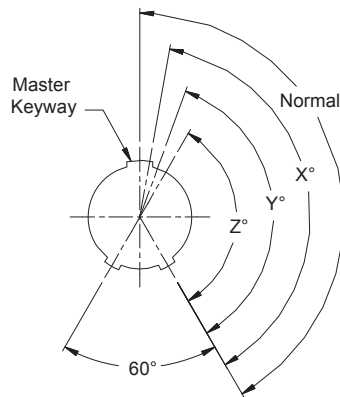

Keyway Positions
(See Table I)
Shell Sizes 5 & 6

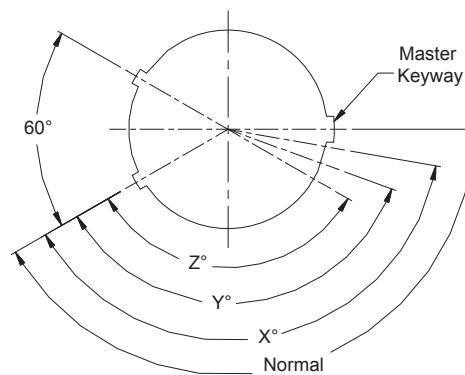

Keyway Positions
(See Table I)
Shell Sizes 7 - 12

Normal	150°
X	140°
Y	130°
Z	120°

Dimensions in inches (millimeters) and are subject to change without notice.

240-800
Series 800 Mighty Mouse Filter Receptacle Connector
UN Mating Threads, Square Flange or Jam Nut



Contact Arrangements					
Contact Arr.	No. of Contacts				
	#23	#20	#20HD	#16	#12
5-3	3				
6-1				1	
6-23			3		
6-4	4				
6-6	6				
6-7	7				
7-1					1
7-25			5		
7-10	10				
8-2				2	
8-28			8		
8-13	13				
8-200	4	2			
9-4				4	
9-210			10		
9-19	19				
9-200	4			2	
9-201	8	2			
10-2					2
10-5				5	
10-26	26				
10-200	12				1
10-201	4				2
10-202	8			2	
12-2					2
12-3					3
12-7				7	
12-220			20		
12-37	37				
12-200	6				2
12-201	10				2

Table II: Connector Class		
Sym	Material	Finish Description
M	Aluminum	Electroless Nickel
MT		Ni-PTFE 1000 Hour Grey™ Nickel Fluorocarbon Polymer
NF		Cadmium, Olive Drab over Electroless Nickel
ZN		Zinc-Nickel, Olive Drab
ZR		Zinc-Nickel, Black - RoHS
ZL	Stainless Steel	Electro-Deposited Nickel

Table III: Capacitor Array Code Capacitance Range		
Class	Pi - Circuit (pF)	C - Circuit (pF)
A	38,000 - 56,000	19,000 - 28,000
B	32,000 - 45,000	16,000 - 22,500
C	18,000 - 33,000	9,000 - 16,500
D	8,000 - 12,000	4,000 - 6,000
E	3,300 - 5,000	1,650 - 2,500
F	800 - 1,300	400 - 650
G	400 - 600	200 - 300
J	70 - 120	35 - 60

Table IV: PC Tail Dia	
Contact Size	Ø U
23	.022 (0.56)
	.018 (0.46)
20	.028 (0.71)
	.024 (0.61)
16	.042 (1.07)
	.038 (0.97)
12	.096 (2.44)
	.092 (2.34)

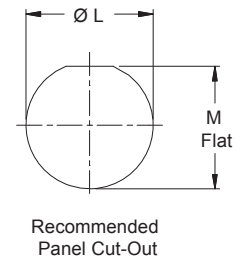
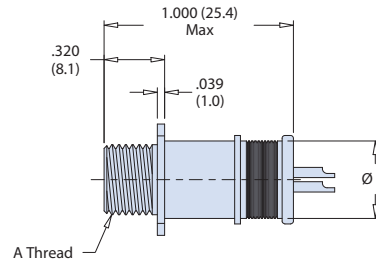
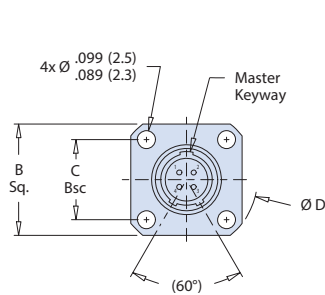
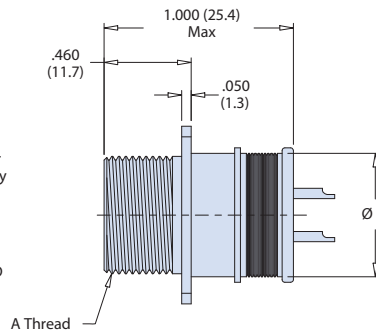
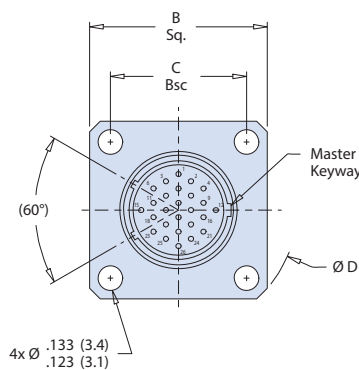

Table V: Dimensions										
Shell Size	A Thread	B Sq.	C Bsc	Ø D	Ø E	Ø G	H Flat	J Flat	Ø L ±.003 (0.05)	M Flat ±.005 (0.13)
5	.3125-28 UN-2A	.527 (13.4)	.363 (9.2)	.680 (17.3)	.365 (9.3)	.541 (13.7)	.500 (12.7)	.285 (7.2)	.297 (7.54)	.322 (8.18)
6	.3750-28 UN-2A	.588 (14.9)	.423 (10.7)	.750 (19.1)	.409 (10.4)	.610 (15.5)	.562 (14.3)	.352 (8.9)	.360 (9.14)	.385 (9.78)
7	.4375-28 UNEF-2A	.650 (16.5)	.483 (12.3)	.830 (21.1)	.500 (12.7)	.670 (17.0)	.635 (16.1)	.411 (10.4)	.426 (10.82)	.447 (11.35)
8	.5000-32 UN-2A	.710 (18.0)	.542 (13.8)	.938 (23.8)	.522 (13.3)	.775 (19.7)	.735 (18.7)	.473 (12.0)	.481 (12.22)	.510 (12.95)
9	.5625-32 UN-2A	.938 (23.8)	.719 (18.3)	1.250 (31.8)	.610 (15.5)	.875 (22.2)	.806 (20.5)	.530 (13.5)	.539 (13.69)	.572 (14.53)
10	.6250-32 UN-2A	.938 (23.8)	.719 (18.3)	1.250 (31.8)	.652 (16.6)	.980 (24.9)	.940 (23.9)	.604 (15.3)	.612 (15.54)	.635 (16.13)
12	.7500-28 UN-2A	1.031 (26.2)	.812 (20.6)	1.375 (34.9)	.746 (18.9)	1.062 (27.0)	.986 (25.0)	.712 (18.1)	.719 (18.26)	.760 (19.30)

Dimensions in inches (millimeters) and are subject to change without notice.



-01 Solder Cup
Sq. Flange Mount
Shell Sizes 5 & 6



-01 Solder Cup
Sq. Flange Mount
Shell Sizes 7 - 12

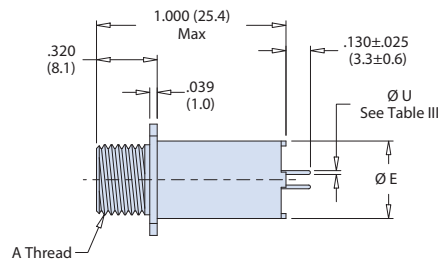
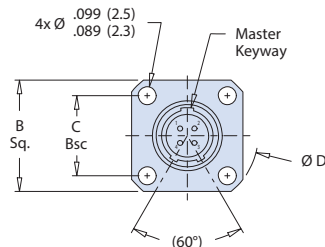

-02 PC Tail
Sq. Flange Mount
Shell Sizes 5 & 6

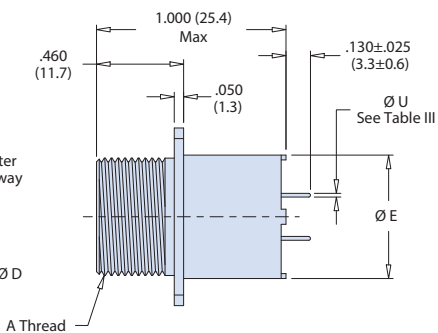
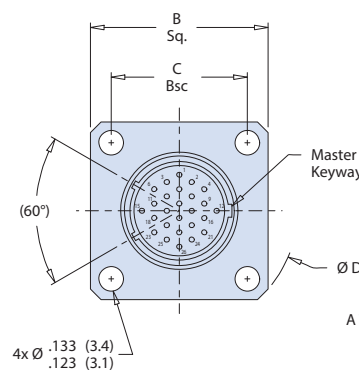

-02 PC Tail
Sq. Flange Mount
Shell Sizes 7 - 12

Dimensions in inches (millimeters) and are subject to change without notice.

240-800
Series 800 Mighty Mouse Filter Receptacle Connector
 UN Mating Threads, Jam Nut



Mighty Mouse

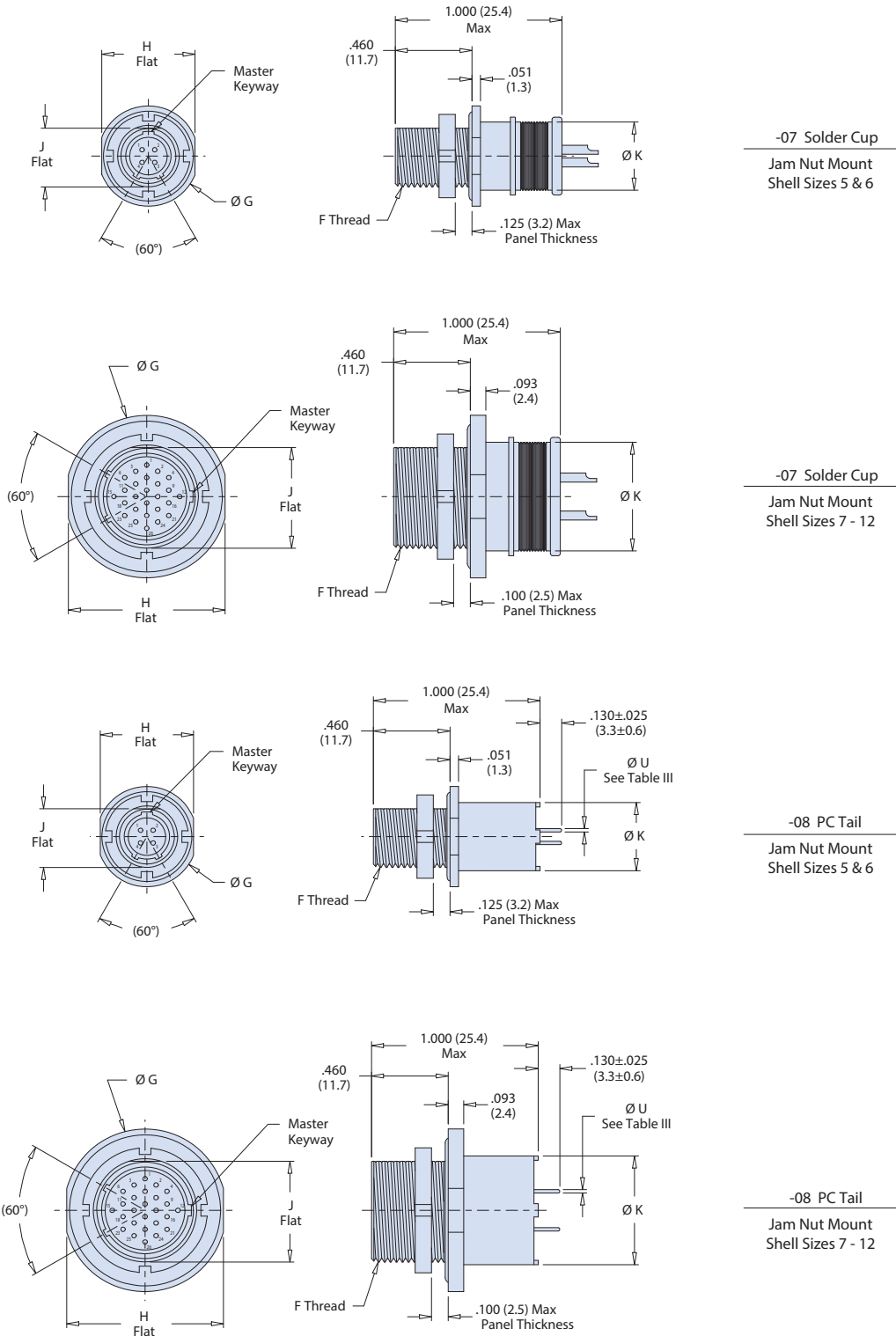

-07 Solder Cup
 Jam Nut Mount
 Shell Sizes 5 & 6

-07 Solder Cup
 Jam Nut Mount
 Shell Sizes 7 - 12

-08 PC Tail
 Jam Nut Mount
 Shell Sizes 5 & 6

-08 PC Tail
 Jam Nut Mount
 Shell Sizes 7 - 12

Dimensions in inches (millimeters) and are subject to change without notice.

C

SERIES 240

Micro-D Filter Connectors



For land, sea, and space applications where guaranteed performance is an absolute mission requirement



Glenair Filter Micro-D connectors are low-pass filters, transmitting DC and low frequency signals while attenuating unwanted high frequency noise. These connectors are available with C filter elements or Pi filters. The filter substrates are constructed with a ceramic planar capacitor array.

Glenair Filter Micro-D's meet the demanding performance requirements of MIL-DTL-83513, except for a reduction in the dielectric withstanding voltage rating to 250 volts DC (higher voltages available on request). The TwistPin contact system assures superior performance in the most demanding applications. Glenair offers the broadest selection of high-availability catalog Micro-D filter connectors, including standard density, high density, mixed power and signal, and more.





Glenair, Inc.
1211 Air Way
Glendale, CA
91201-2497
818-247-6000
sales@glenair.com
www.glenair.com

Micro-D MIL-DTL-83513 Type Filter Connectors

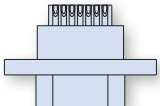
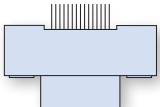
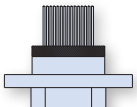
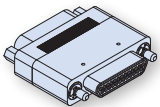
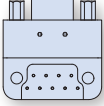
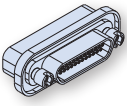
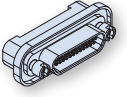
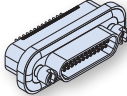
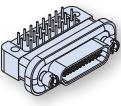
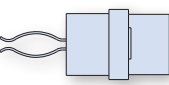
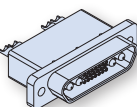

Micro-D
MIL-DTL-83513 Type

Product Selection Guide

240-030 Page D-7		Solder Cup Micro-D Filter Connector
240-031 Page D-9		Vertical PCB Micro-D Filter Connector
240-032 Page D-14		Insulated Wire Micro-D Filter Connector
240-033 Page D-16		In-Line Micro-D Filter Adapter
240-034 Page D-18		Right Angle PCB Micro-D Filter Connector
240-075 Page D-23		Rear Panel Mount Solder Cup Micro-D Filter Connector
240-076 Page D-25		Rear Panel Mount Vertical PCB Micro-D Filter Connector
240-077 Page D-27		Rear Panel Mount Insulated Wire Micro-D Filter Connector
240-078 Page D-29		Rear Panel Mount Condensed Board Right Angle Micro-D Filter Connector
247-379 Page D-31		Edge Board Micro-D Filter Connector
2470-1048 Page D-36		Combo Micro-D Filter connector
249-EMITS-MICRO Page D-37		EMI Troubleshooter Kit for Micro-D Connectors

D

Dimensions in inches (millimeters) and are subject to change without notice.

© 2013 Glenair, Inc.

U.S. CAGE Code 06324

Printed in U.S.A.



Micro-D Filter Connectors General Information

ABOUT MICRO-D FILTER CONNECTORS

Glenair Filter Micro-D connectors are low-pass filters, transmitting DC and low frequency signals while attenuating unwanted high frequency noise. These connectors are available with C filter elements or Pi filters. The filter substrates are constructed with a ceramic planar capacitor array.

Glenair Filter Micro-D's meet the demanding performance requirements of MIL-DTL-83513, except for a reduction in the dielectric withstanding voltage rating to 250 volts DC (higher voltages available on request). The TwistPin contact system assures superior performance in the most demanding applications.

C Filter

Single capacitor with low self inductance. This configuration is generally used to attenuate high frequency signals. The simple design allows high-frequency EMI to discharge to ground via the surrounding electromagnetic field. C filters occupy the least amount of space and offer lower cost compared to other filter types.

Pi Filter

Dual capacitors with a ferrite inductor positioned between them. The Pi filter provides excellent high-frequency performance due to its sharper rolloff.

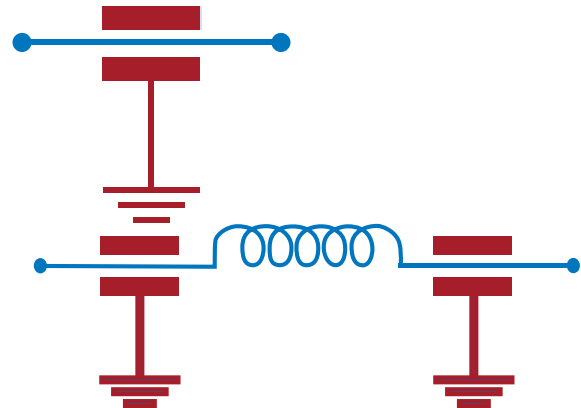

D

Micro-D C Filter Attenuation and Capacitance Values

C Filter	Filter Class	Capacitance pF	No Load Insertion Loss (dB Minimum)			
			1 MHz	10 MHz	100 MHz	500-1000 MHz
	A	19,000 — 28,000	6	24	41	50
	B	16,000 — 22,500	5	23	39	49
	C	9,000 — 16,500	3	16	35	46
	D	4,000 — 6,000	—	8	28	41
	E	1,650 — 2,500	—	4	21	34
	F	400 — 650	—	—	10	23
	G	200 — 300	—	—	5	17
	J	35 — 60	—	—	1	8

Micro-D Pi Filter Attenuation and Capacitance Values

Pi Filter	Filter Class	Capacitance pF	No Load Insertion Loss (dB Minimum)			
			1 MHz	10 MHz	100 MHz	500-1000 MHz
	A	38,000 — 56,000	10	40	62	66
	B	32,000 — 45,000	8	35	60	62
	C	18,000 — 33,000	5	25	57	60
	D	8,000 — 12,000	1	14	50	58
	E	3,300 — 5,000	—	8	40	52
	F	800 — 1,300	—	2	15	32
	G	400 — 600	—	0.8	13	22
	J	70 — 120	—	—	4	15

Dimensions in inches (millimeters) and are subject to change without notice.

Micro-D Filter Connectors General Information



Micro-D
MIL-DTL-83513 Type

Micro-D Filter Connector Contact Arrangements (Face View Pin Connector)

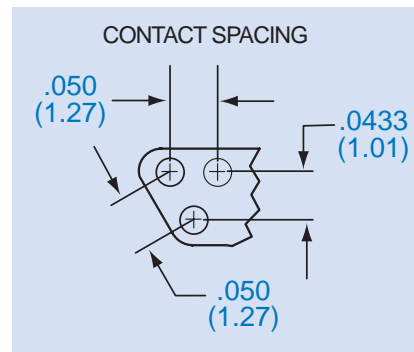
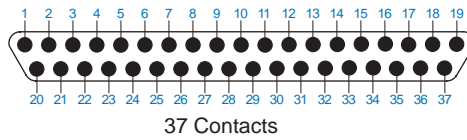
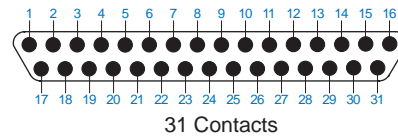
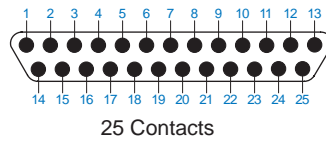
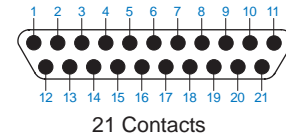
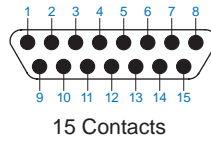
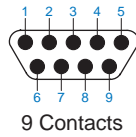

* Consult factory for filtered Micro-D connectors in other arrangements

Performance Specifications	
Current Rating	3 AMP
Dielectric Withstanding Voltage	250 VDC
Working Voltage	100 VDC
Insulation Resistance	5000 Megohms Minimum
Contact Resistance	8 milliohms Maximum
Low Level Contact Resistance	32 milliohms Maximum
Magnetic Permeability	2 μ Maximum
Operating Temperature	-55° C to +125° C
Shock	50 g.
Vibration	20 g.
Mating Force	(10 oz) x (# of Contacts)
Capacitance and Attenuation	(See Table on Preceding Page)

Materials and Finishes	
Connector Shell	Aluminum Alloy 6061 or Stainless Steel, 300 Series, Passivated. See Ordering Info for Aluminum Plating Options.
Insulator	Liquid Crystal Polymer (LCP)
Seals	Fluorosilicone Rubber, Blue
Pin Contact	Beryllium Copper With 50 microinches Gold over Nickel Plating
Socket Contact	Copper Alloy With 50 microinches Gold Over Nickel Plating
Hardware	300 Series Stainless Steel
PCB Terminals	Gold-Plated Copper Alloy, Solder Dipped
Capacitors	Planar Ceramic Array
Inductors	Ferrite
EMI Ground Spring	Beryllium Copper, Gold Plated
Encapsulant	Thermally Conductive Epoxy

Dimensions in inches (millimeters) and are subject to change without notice.

D

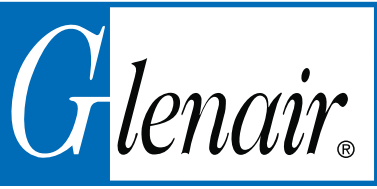

Micro-D Filter Connectors Recommended Panel Cutouts

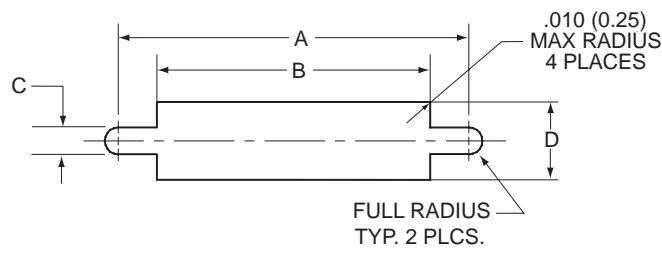

Front Panel Mounting

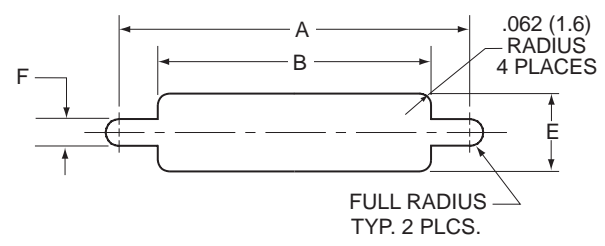

Rear Panel Mounting

D

Metal Shell MWDM Connectors												
Layout	A		B		C		D		E		F	
	In. ± .003	mm. ± 0.08	In. ± .002	mm. ± 0.05	In. ± .002	mm. ± 0.05	In. ± .002	mm. ± 0.05	In. ± .005	mm. ± 0.13	In. ± .002	mm. ± 0.05
9	.565	14.35	.410	10.41	.091	2.31	.290	7.37	.256	6.50	.126	3.20
15	.715	18.16	.560	14.22	.091	2.31	.290	7.37	.256	6.50	.126	3.20
21	.865	21.97	.710	18.03	.091	2.31	.290	7.37	.256	6.50	.126	3.20
25	.965	24.51	.810	20.57	.091	2.31	.290	7.37	.256	6.50	.126	3.20
31	1.115	28.32	.960	24.38	.091	2.31	.290	7.37	.256	6.50	.126	3.20
37	1.265	32.13	1.110	28.19	.091	2.31	.290	7.37	.256	6.50	.126	3.20

Note: For front panel mounting, filtered connectors require a larger cut-out than standard MIL-DTL-83513 connectors.

Dimensions in inches (millimeters) and are subject to change without notice.

MIL-STD-681 Color Code Chart



Micro-D
MIL-DTL-83513 Type

MIL-STD-681 Color Code Chart For Micro-D Connectors

PIN NO.	MIL-STD-681 NUMBER	Base Color	First Stripe	Second Stripe	PIN NO.	MIL-STD-681 NO.	Base Color	First Stripe	Second Stripe	Third Stripe
1	0	BLK			51	957	WHT	GRN	VIO	
2	1	BRN			52	958	WHT	GRN	GRY	
3	2	RED			53	967	WHT	BLU	VIO	
4	3	ORN			54	968	WHT	BLU	GRY	
5	4	YEL			55	978	WHT	VIO	GRY	
6	5	GRN			56	9012	WHT	BLK	BRN	RED
7	6	BLU			57	9013	WHT	BLK	BRN	ORN
8	7	VIO			58	9014	WHT	BLK	BRN	YEL
9	8	GRY			59	9015	WHT	BLK	BRN	GRN
10	9	WHT			60	9016	WHT	BLK	BRN	BLU
11	90	WHT	BLK		61	9017	WHT	BLK	BRN	VIO
12	91	WHT	BRN		62	9018	WHT	BLK	BRN	GRY
13	92	WHT	RED		63	9023	WHT	BLK	RED	ORN
14	93	WHT	ORN		64	9024	WHT	BLK	RED	YEL
15	94	WHT	YEL		65	9025	WHT	BLK	RED	GRN
16	95	WHT	GRN		66	9026	WHT	BLK	RED	BLU
17	96	WHT	BLU		67	9027	WHT	BLK	RED	VIO
18	97	WHT	VIO		68	9028	WHT	BLK	RED	GRY
19	98	WHT	GRY		69	9034	WHT	BLK	ORN	YEL
20	901	WHT	BLK	BRN	70	9035	WHT	BLK	ORN	GRN
21	902	WHT	BLK	RED	71	9036	WHT	BLK	ORN	BLU
22	903	WHT	BLK	ORN	72	9037	WHT	BLK	ORN	VIO
23	904	WHT	BLK	YEL	73	9038	WHT	BLK	ORN	GRY
24	905	WHT	BLK	GRN	74	9045	WHT	BLK	YEL	GRN
25	906	WHT	BLK	BLU	75	9046	WHT	BLK	YEL	BLU
26	907	WHT	BLK	VIO	76	9047	WHT	BLK	YEL	VIO
27	908	WHT	BLK	GRY	77	9048	WHT	BLK	YEL	GRY
28	912	WHT	BRN	RED	78	9056	WHT	BLK	GRN	BLU
29	913	WHT	BRN	ORN	79	9057	WHT	BLK	GRN	VIO
30	914	WHT	BRN	YEL	80	9058	WHT	BLK	GRN	GRY
31	915	WHT	BRN	GRN	81	9067	WHT	BLK	BLU	VIO
32	916	WHT	BRN	BLU	82	9068	WHT	BLK	BLU	GRY
33	917	WHT	BRN	VIO	83	9078	WHT	BLK	VIO	GRY
34	918	WHT	BRN	GRY	84	9123	WHT	BRN	RED	ORN
35	923	WHT	RED	ORN	85	9124	WHT	BRN	RED	YEL
36	924	WHT	RED	YEL	86	9125	WHT	BRN	RED	GRN
37	925	WHT	RED	GRN	87	9126	WHT	BRN	RED	BLU
38	926	WHT	RED	BLU	88	9127	WHT	BRN	RED	VIO
39	927	WHT	RED	VIO	89	9128	WHT	BRN	RED	GRY
40	928	WHT	RED	GRY	90	9134	WHT	BRN	ORN	YEL
41	934	WHT	ORN	YEL	91	9135	WHT	BRN	ORN	GRN
42	935	WHT	ORN	GRN	92	9136	WHT	BRN	ORN	BLU
43	936	WHT	ORN	BLU	93	9137	WHT	BRN	ORN	VIO
44	937	WHT	ORN	VIO	94	9138	WHT	BRN	ORN	GRY
45	938	WHT	ORN	GRY	95	9145	WHT	BRN	YEL	GRN
46	945	WHT	YEL	GRN	96	9146	WHT	BRN	YEL	BLU
47	946	WHT	YEL	BLU	97	9147	WHT	BRN	YEL	VIO
48	947	WHT	YEL	VIO	98	9148	WHT	BRN	YEL	GRY
49	948	WHT	YEL	GRY	99	9156	WHT	BRN	GRN	BLU
50	956	WHT	GRN	BLU	100	9157	WHT	BRN	GRN	VIO

Dimensions in inches (millimeters) and are subject to change without notice.

© 2013 Glenair, Inc.

U.S. CAGE Code 06324

Printed in U.S.A.

D



Micro-D Filter Connectors Special Products

FILTER CONNECTORS FOR SPACE FLIGHT

Connector Material and Finish Options for Space Applications

- **Cadmium and silver plating are prohibited in space.**
- **Specify electroless nickel or gold for connector finish**

Some types of metals are prohibited for space flight. "Cadmium, zinc, chemically coated cadmium or zinc, or silver shall not be used as a connector or contact finish" (NASA EEE-INST-002: Instructions for EEE Parts Selection, Screening, Qualification, and Derating). NASA recommends electroless nickel or gold plating on connector shells and gold plating for contacts.

Outgassing

- **Standard filter connectors require thermal vacuum bakeout to meet outgassing requirements**
- **NASA screened filter connectors meet outgassing requirements**

Some flight equipment requires low-outgassing components in order to prevent degradation to optics and other sensitive instruments. The space industry has adopted a standardized test procedure, ASTM E595, to evaluate outgassing properties. In order to be considered outgassing compatible, a material must exhibit a total mass loss (TML) of less than 1.0% and a collected volatile condensable material (CVCM) of less than 0.1%. Some of the materials used in filter connectors, like fluorosilicone interfacial seals, must go through special processing to meet TML and CVCM requirements. Per EEE-INST-002, filter connectors subjected to +125° C as part of voltage conditioning do not require additional processing to meet the outgassing requirements. If processing is required, Glenair offers a 24 hour thermal vacuum outgassing at 125° C for filter connectors.

NASA Screening

- **"Mission critical" connectors for space flight should undergo rigorous 100% final inspection.**
- **Modification codes are available to invoke special screening.**

NASA recommends that connectors for space flight be specially screened. EEE-INST-002 contains three levels of screening: Level 1 for highest reliability with the lowest level of risk, Level 2 for high reliability with low to moderate risk, and Level 3 for standard reliability.

NASA Screening Levels and Modification Codes

NASA Screening Level	Screening	Screening & X-Ray Inspection
Level 1: Highest Reliability	Mod 429B	Mod 429R
Level 2: High Reliability	Mod 429	Mod 429S
Level 3: Standard Reliability	Mod 429L	Mod 429T

X-Ray Inspection



Real-Time X-Ray Machine

To reduce risk even further for mission critical applications, x-ray inspection on a real-time x-ray system is available. Samples subject to x-ray inspection per Mod code 844 will be screened for foreign object debris (FOD) and if applicable, broken strands. A minimum of two views for each sample will be stored and are available upon request.

Add the MOD codes listed in the table below to the end of a part number to invoke special test or processing requirements.

Thermal Vacuum Outgassing	Mod 186M
X-Ray Inspection	Mod 844

Dimensions in inches (millimeters) and are subject to change without notice.

240-030 Micro-D Filter Connectors Solder Cup



Micro-D
MIL-DTL-83513 Type



Glenair Filtered Solder Cup Micro-D's provide EMI solutions in a miniaturized M83513 type connector. These connectors feature ceramic capacitor planar arrays and ferrite inductors. Solder cups accept #24 thru #30 AWG wire.

Choose Pi or C Filter Arrays in eight filter classes and six layouts. Glenair filtered Micro-D connectors comply with applicable MIL-DTL-83513 requirements and are 100% intermateable with standard connectors.

Choose 9 to 37 Contacts, with standard cadmium or nickel plating on the connector housing or choose optional finishes such as gold or chem film.

How To Order Filter Micro-D Connectors with Solder Cups								
Sample Part Number	240-030		-2	-25	P	P	B	B
Series	240-030							
Shell Finish	Aluminum Shell 1 - Cadmium 2 - Nickel 4 - Black Anodize 5 - Gold 6 - Chem Film		Stainless Steel Shell 3 - Passivated					
Contact Layout	9, 15, 21, 25, 31, 37 (See Table III)							
Contact Type	Solder Cup Contacts for #24 AWG or Smaller Wire P - Pin S - Socket							
Filter Type	C - C Filter P - Pi Filter (See Table II)							
Filter Class	A, B, C, D, E, F, G, J (See Table II)							
Hardware	B, P, M, M1, S, S1, L, K, H (See Table I)							

D

Table I: Micro-D Mounting Hardware								
B	P	M	M1	S	S1	L	K	H
Thru-Hole Order Hardware Separately	Jackpost Removable Includes Nut and Washer	Jackscrew Hex Head Removable E-ring	Jackscrew Hex Head Removable E-ring Extended	Jackscrew Slot Head Removable E-ring	Jackscrew Slot Head Removable E-ring Extended	Jackscrew Hex Head Non- Removable	Jackscrew Slot Head Non- Removable Extended	Threaded Insert

Dimensions in inches (millimeters) and are subject to change without notice.

Rev. 05.29.19

© 2013 Glenair, Inc.

U.S. CAGE Code 06324

Printed in U.S.A.

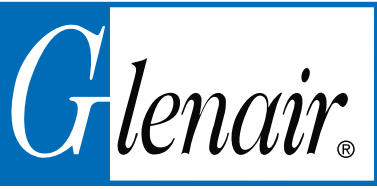

240-030 Micro-D Filter Connectors Solder Cup

Table II: Micro-D Filter Classes and Performance

Filter Class	A	B	C	D	E	F	G	J
Capacitance (pF)								
C Filter	19000-28000	16000-22500	9000-16500	4000-6000	1650-2500	400-650	200-300	35-60
Pi Filter	38000-56000	32000-45000	18000-33000	8000-12000	3300-5000	800-1300	400-600	70-120

Table III: Dimensions

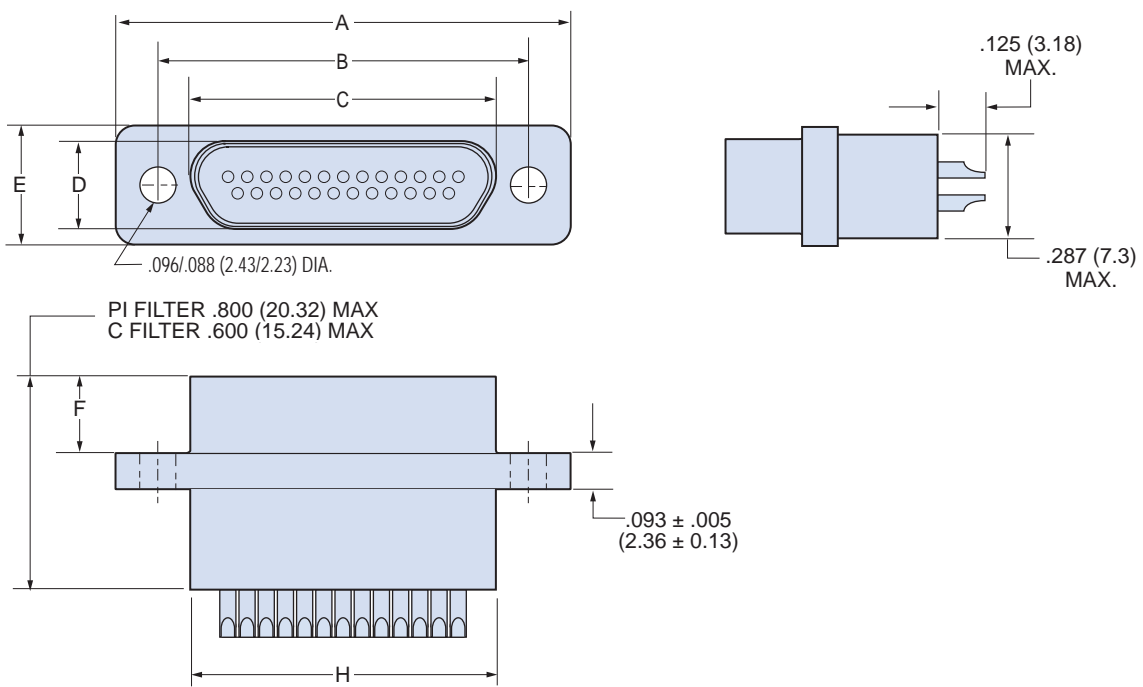

Layout	A Max		B		C Max.		D Max.		E Max.		F		H Max.	
	In.	mm.	In. ± .003	mm. ± 0.08	In.	mm.	In.	mm.	In.	mm.	In. ± .003	mm. ± 0.08	In.	mm.
9P	.785	19.94	.565	14.35	.333	8.46	.184	4.67	.322	8.18	.183	4.65	.400	10.16
9S	.785	19.94	.565	14.35	.400	10.16	.250	6.35	.322	8.18	.195	4.95	.400	10.16
15P	.935	23.75	.715	18.16	.483	12.27	.184	4.67	.322	8.18	.183	4.65	.550	13.97
15S	.935	23.75	.715	18.16	.551	14.00	.250	6.35	.322	8.18	.195	4.95	.550	13.97
21P	1.085	27.56	.865	21.97	.633	16.08	.184	4.67	.322	8.18	.183	4.65	.700	17.78
21S	1.085	27.56	.865	21.97	.701	17.81	.250	6.35	.322	8.18	.195	4.95	.700	17.78
25P	1.185	30.10	.965	24.51	.733	18.62	.184	4.67	.322	8.18	.183	4.65	.800	20.32
25S	1.185	30.10	.965	24.51	.801	20.35	.250	6.35	.322	8.18	.195	4.95	.800	20.32
31P	1.335	33.91	1.115	28.32	.883	22.43	.184	4.67	.322	8.18	.183	4.65	.950	24.13
31S	1.335	33.91	1.115	28.32	.951	24.16	.250	6.35	.322	8.18	.195	4.95	.950	24.13
37P	1.485	37.72	1.265	32.13	1.033	26.24	.184	4.67	.322	8.18	.183	4.65	1.100	27.94
37S	1.485	37.72	1.265	32.13	1.101	27.96	.250	6.35	.322	8.18	.195	4.95	1.100	27.94

Dimensions in inches (millimeters) and are subject to change without notice.

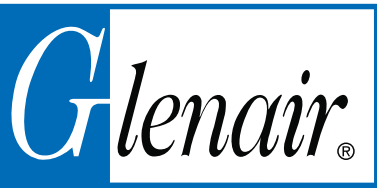

240-031 PCB Micro-D Filter Connectors Vertical Mount

Table II: Dimensional Table Micro-D Filter Vertical PCB Dimensions

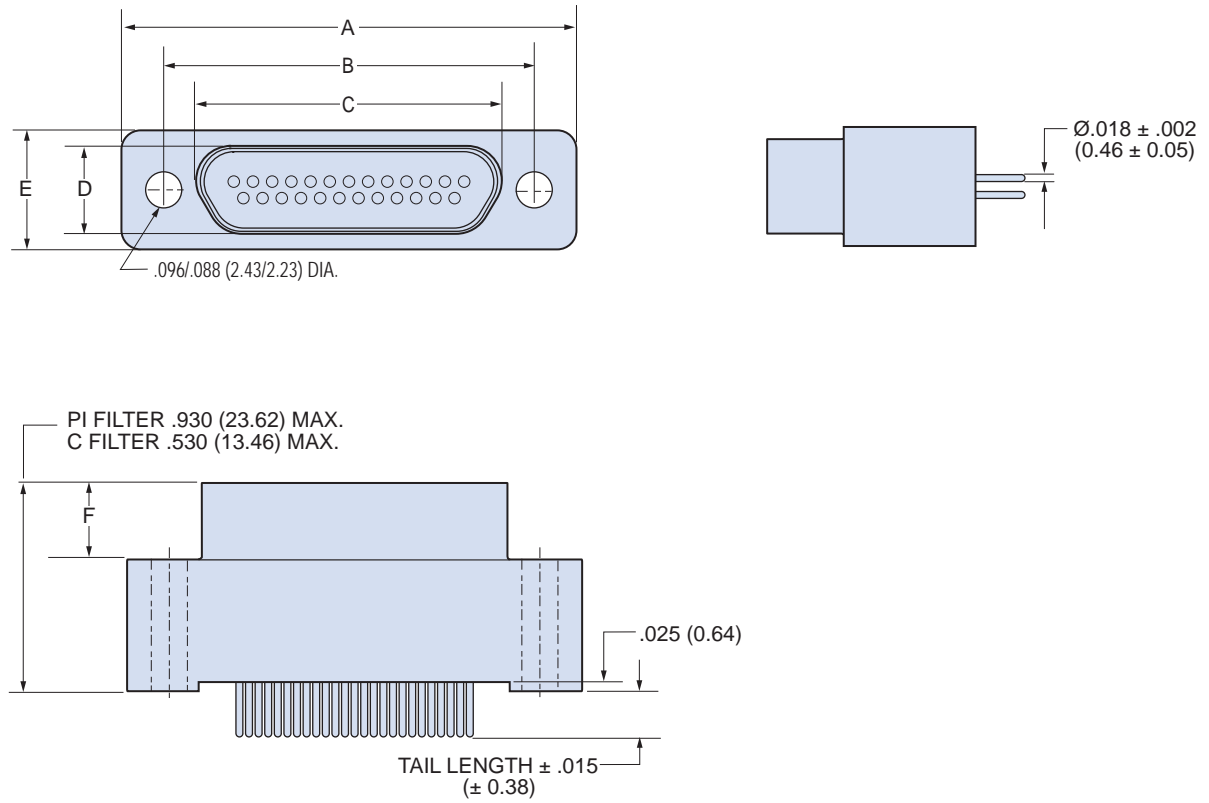

D

Layout	A Max.		B		C Max.		D Max.		E Max.		F	
	In.	mm.	In. ± .003	mm. ± 0.08	In.	mm.	In.	mm.	In.	mm.	In. ± .004	mm. ± 0.10
9P	.785	19.94	.565	14.35	.333	8.46	.184	4.67	.310	7.87	.183	4.65
9S	.785	19.94	.565	14.35	.400	10.16	.250	6.35	.310	7.87	.195	4.95
15P	.935	23.75	.715	18.16	.483	12.27	.184	4.67	.310	7.87	.183	4.65
15S	.935	23.75	.715	18.16	.551	14.00	.250	6.35	.310	7.87	.195	4.95
21P	1.085	27.56	.865	21.97	.633	16.08	.184	4.67	.310	7.87	.183	4.65
21S	1.085	27.56	.865	21.97	.701	17.81	.250	6.35	.310	7.87	.195	4.95
25P	1.185	30.10	.965	24.51	.733	18.62	.184	4.67	.310	7.87	.183	4.65
25S	1.185	30.10	.965	24.51	.801	20.35	.250	6.35	.310	7.87	.195	4.95
31P	1.335	33.91	1.115	28.32	.883	22.43	.184	4.67	.310	7.87	.183	4.65
31S	1.335	33.91	1.115	28.32	.951	24.16	.250	6.35	.310	7.87	.195	4.95
37P	1.485	37.72	1.265	32.13	1.033	26.24	.184	4.67	.310	7.87	.183	4.65
37S	1.485	37.72	1.265	32.13	1.101	27.96	.250	6.35	.310	7.87	.195	4.95

Dimensions in inches (millimeters) and are subject to change without notice.

240-031
Vertical Mount PCB Micro-D Filter Connectors
Hardware Options



Micro-D
MIL-DTL-83513 Type

D

Micro-D Filter Vertical PCB Hardware Options

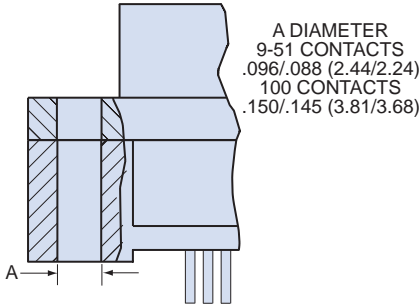

NN Style
Connector Supplied Without Hardware
Thru-Hole, No Hardware

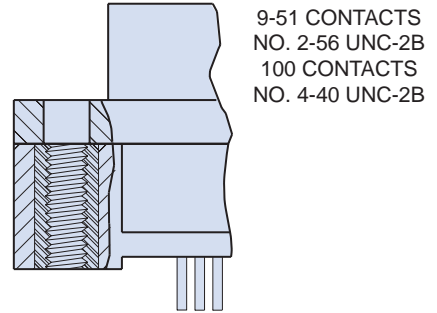

NU Style
Connector Supplied With Threaded Inserts

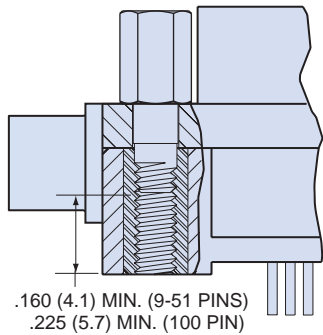

PU Style
Jackpost with Threaded Insert

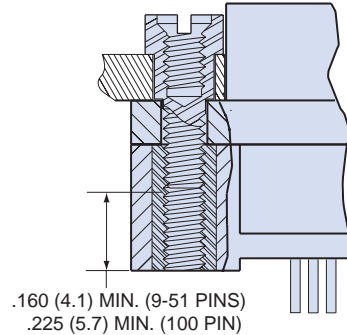

RU Style
Rear Panel Jackpost with Threaded Insert

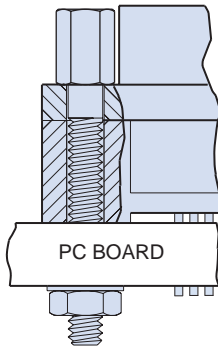

Extended Jackpost
PN Style
for .062" PCB

RN Style
for .196" PCB

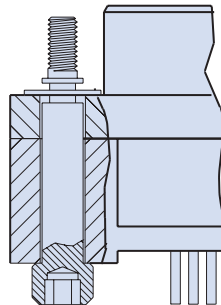

M Style
Hex Head Jackscrew with E-Ring

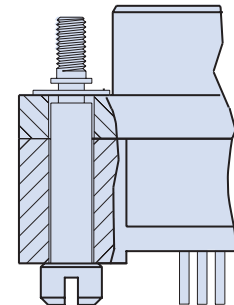

S Style
Slot Head Jackscrew with E-Ring

Dimensions in inches (millimeters) and are subject to change without notice.

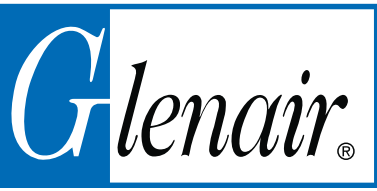

240-031 Vertical Mount PCB Micro-D Filter Connectors PCB Layouts

Micro-D Filter Vertical PCB Layouts — Pin Connector Shown

PC Tail Diameter $.018 \pm .002$ (0.46 \pm 0.05)
Contact numbers shown are for pin connectors.

D

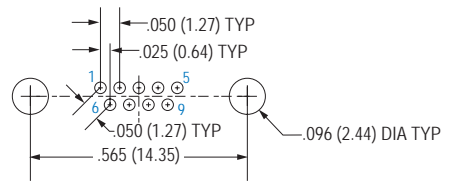

9 CONTACTS

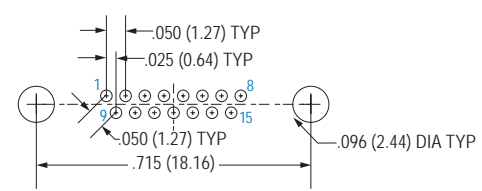

15 CONTACTS

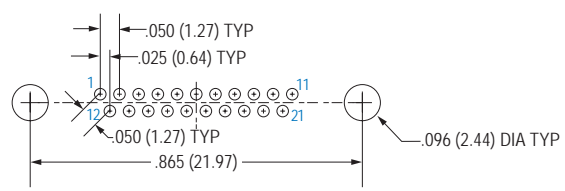

21 CONTACTS

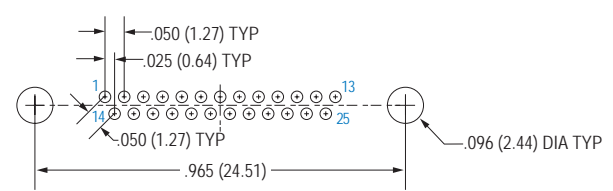

25 CONTACTS

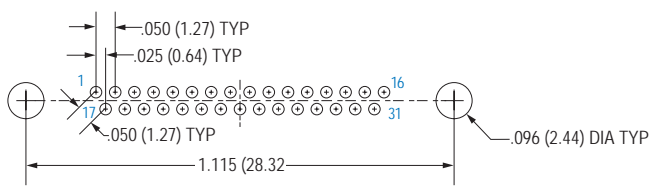

31 CONTACTS

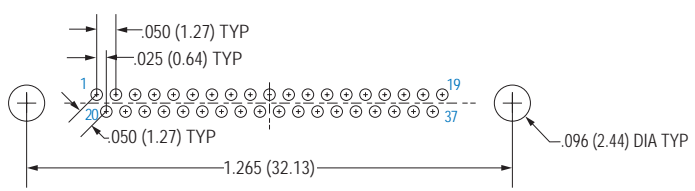

37 CONTACTS

Dimensions in inches (millimeters) and are subject to change without notice.

240-031
Vertical Mount PCB Micro-D Filter Connectors
PCB Layouts



Micro-D
MIL-DTL-83513 Type

Micro-D Filter Vertical PCB Layouts — Socket Connector Shown

PC Tail Diameter $.018 \pm .002$ (0.46 ± 0.05)
Contact numbers shown are for socket connectors.

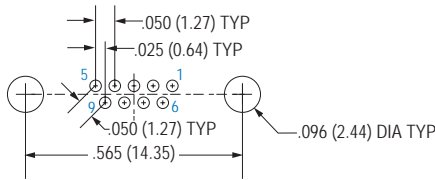

9 CONTACTS

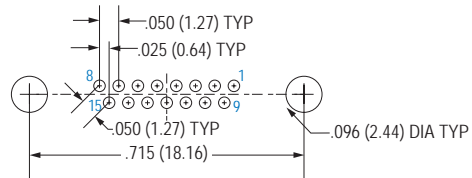

15 CONTACTS

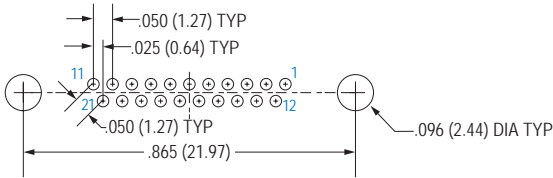

21 CONTACTS

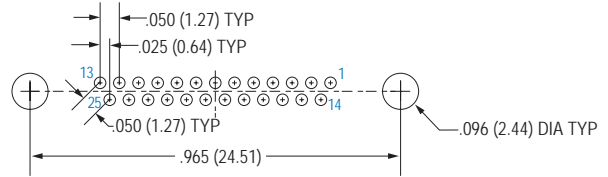

25 CONTACTS

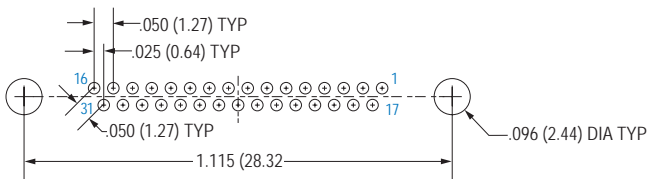

31 CONTACTS

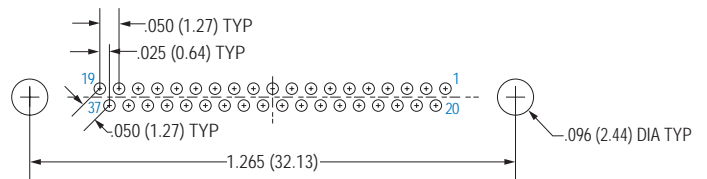

37 CONTACTS

Dimensions in inches (millimeters) and are subject to change without notice.

D



240-032 Pre-Wired Micro-D Filter Connectors Insulated Wire



Glenair Filtered Pigtail Micro-D's provide EMI solutions in a miniaturized M83513 Micro-D connector. These connectors feature ceramic capacitor planar arrays and ferrite inductors. Insulated wire is factory precision-crimped to TwistPin contacts for superior reliability in the most demanding environments.

Choose Pi or C Filter Arrays in eight filter classes and six layouts. Glenair filtered Micro-D connectors comply with applicable MIL-DTL-83513 requirements and are 100% intermateable with standard connectors.

Choose 9 to 37 Contacts, with standard cadmium or nickel plating on the connector housing or choose optional finishes such as gold or chem film.

D

How To Order Filter Micro-D Connectors with Insulated Wire Pigtailed	
Sample Part Number	240-032 -2 -25 P P B 6 K 1 -18 B
Series	240-032
Shell Finish	Aluminum Shell Stainless Steel Shell 1 - Cadmium 2 - Nickel 3 - Passivated 4 - Black Anodize 5 - Gold 6 - Chem Film
Contact Layout	9, 15, 21, 25, 31, 37 (See Table II)
Contact Type	Solder Cup Contacts for #24 AWG or Smaller Wire P - Pin S - Socket
Filter Type	C - C Filter P - Pi Filter (See Table I)
Filter Class	A, B, C, D, E, F, G, J
Wire Gage (AWG)	4 - #24 6 - #26
Wire Type	K - M22759/11 600 Vrms Fluoropolymer (TFE) J - M22759/33 600 Vrms Modified Cross-Linked Tefzel® (ETFE)
Wire Color	1 - White 2 - Yellow 5 - Color-Coded Stripes Per MIL-STD-681(#24 and #26 gage only) 7 - Ten Color Repeat
Wire Length Inches	18 wire Length In Inches. "18" Specifies 18 Inches.
Hardware	B, P, M, M1, S, S1, L, K, H (See Table I)

Table I: Micro-D Mounting Hardware								
B	P	M	M1	S	S1	L	K	H
Thru-Hole Order Hardware Separately	Jackpost Removable Includes Nut and Washer	Jackscrew Hex Head Removable E-ring	Jackscrew Hex Head Removable E-ring Extended	Jackscrew Slot Head Removable E-ring	Jackscrew Slot Head Removable E-ring Extended	Jackscrew Hex Head Non- Removable	Jackscrew Slot Head Non- Removable Extended	Threaded Insert

Dimensions in inches (millimeters) and are subject to change without notice.

240-032 Pre-Wired Micro-D Filter Connectors Insulated Wire



Micro-D
MIL-DTL-83513 Type

Table II: Micro-D Filter Classes and Performance

Filter Class	A	B	C	D	E	F	G	J
Capacitance (pF)								
C Filter	19000-28000	16000-22500	9000-16500	4000-6000	1650-2500	400-650	200-300	35-60
Pi Filter	38000-56000	32000-45000	18000-33000	8000-12000	3300-5000	800-1300	400-600	70-120

Table II: Dimensions

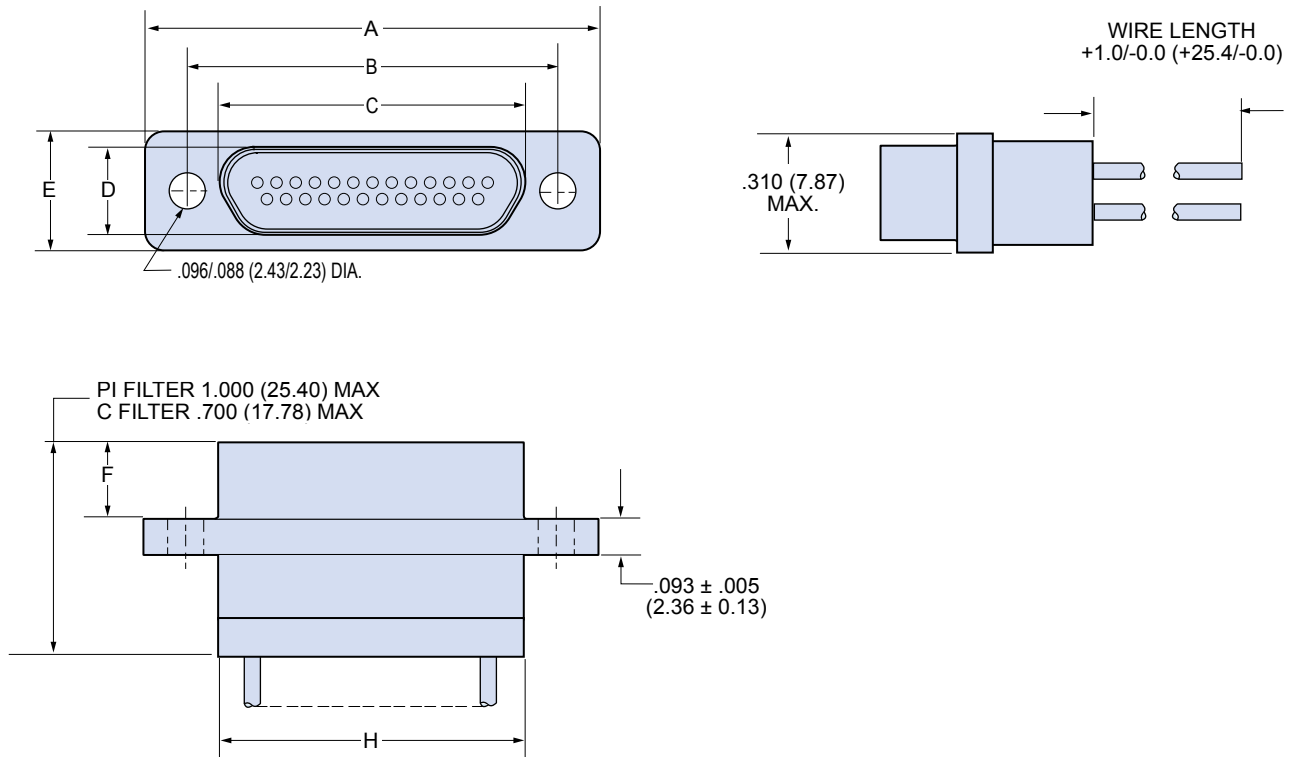

D

Layout	A Max		B		C Max.		D Max.		E Max.		F		H Max.	
	In.	mm.	In. ± .003	mm. ± 0.08	In.	mm.	In.	mm.	In.	mm.	In. ± .004	mm. ± 0.10	In.	mm.
9P	.785	19.94	.565	14.35	.333	8.46	.184	4.67	.322	8.18	.183	4.65	.400	10.16
9S	.785	19.94	.565	14.35	.400	10.16	.250	6.35	.322	8.18	.195	4.95	.400	10.16
15P	.935	23.75	.715	18.16	.483	12.27	.184	4.67	.322	8.18	.183	4.65	.550	13.97
15S	.935	23.75	.715	18.16	.551	14.00	.250	6.35	.322	8.18	.195	4.95	.550	13.97
21P	1.085	27.56	.865	21.97	.633	16.08	.184	4.67	.322	8.18	.183	4.65	.700	17.78
21S	1.085	27.56	.865	21.97	.701	17.81	.250	6.35	.322	8.18	.195	4.95	.700	17.78
25P	1.185	30.10	.965	24.51	.733	18.62	.184	4.67	.322	8.18	.183	4.65	.800	20.32
25S	1.185	30.10	.965	24.51	.801	20.35	.250	6.35	.322	8.18	.195	4.95	.800	20.32
31P	1.335	33.91	1.115	28.32	.883	22.43	.184	4.67	.322	8.18	.183	4.65	.950	24.13
31S	1.335	33.91	1.115	28.32	.951	24.16	.250	6.35	.322	8.18	.195	4.95	.950	24.13
37P	1.485	37.72	1.265	32.13	1.033	26.24	.184	4.67	.322	8.18	.183	4.65	1.100	27.94
37S	1.485	37.72	1.265	32.13	1.101	27.96	.250	6.35	.322	8.18	.195	4.95	1.100	27.94

Dimensions in inches (millimeters) and are subject to change without notice.

© 2013 Glenair, Inc.

U.S. CAGE Code 06324

Printed in U.S.A.

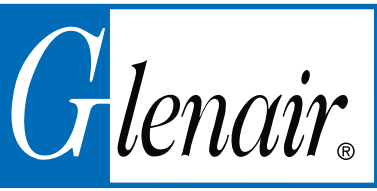

240-033 Micro-D Pin-Socket In-Line Filter Adapters



Avoid Costly Redesign with Micro-D Filter Adapters. Upgrade your existing cables and boxes to meet EMI requirements. These pin-socket adapters can be plugged into any standard M83513 connectors. Simply unplug your existing cable, install the filter adapter, and plug the cable into the adapter.

In-Line Filter Adapters feature gold plated TwistPin contacts, machined aluminum shells, and either Pi or C filter elements. These environmentally sealed adapters are designed to meet the requirements of MIL-DTL-83513.

D

How To Order Micro-D In-Line Filter Adapters		240-033	-2	-21	PS	C	D	P
Sample Part Number								
Series	240-033							
Shell Finish	Aluminum Shell 1 - Cadmium 4 - Black Anodize 6 - Chem Film 2 - Nickel 5 - Gold 3 - Passivated							
Contact Layout	9, 15, 21, 25, 31, 37 (See Table II)							
Contact Type	PS - Pin/Socket							
Filter Type	C - C Filter P - Pi Filter							
Filter Class	A, B, C, D, E, F, G, J (See Table I)							
Hardware	N - No Hardware P - Combination Jackscrew and Jackpost							

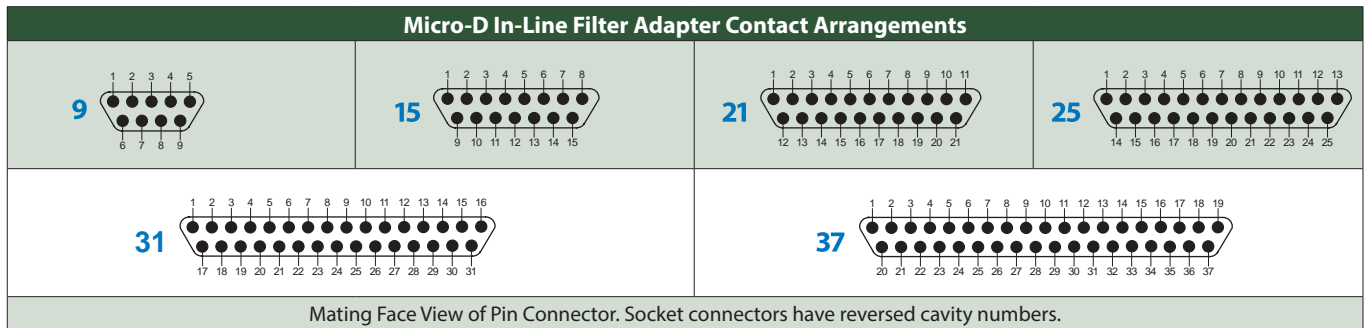

Filter Class	A	B	C	D	E	F	G	J
Capacitance (pF)								
C Filter	19000-28000	16000-22500	9000-16500	4000-6000	1650-2500	400-650	200-300	35-60
Pi Filter	38000-56000	32000-45000	18000-33000	8000-12000	3300-5000	800-1300	400-600	70-120

Dimensions in inches (millimeters) and are subject to change without notice.

240-033 Micro-D Pin-Socket In-Line Filter Adapters



Micro-D
MIL-DTL-83513 Type

Table II: Dimensions

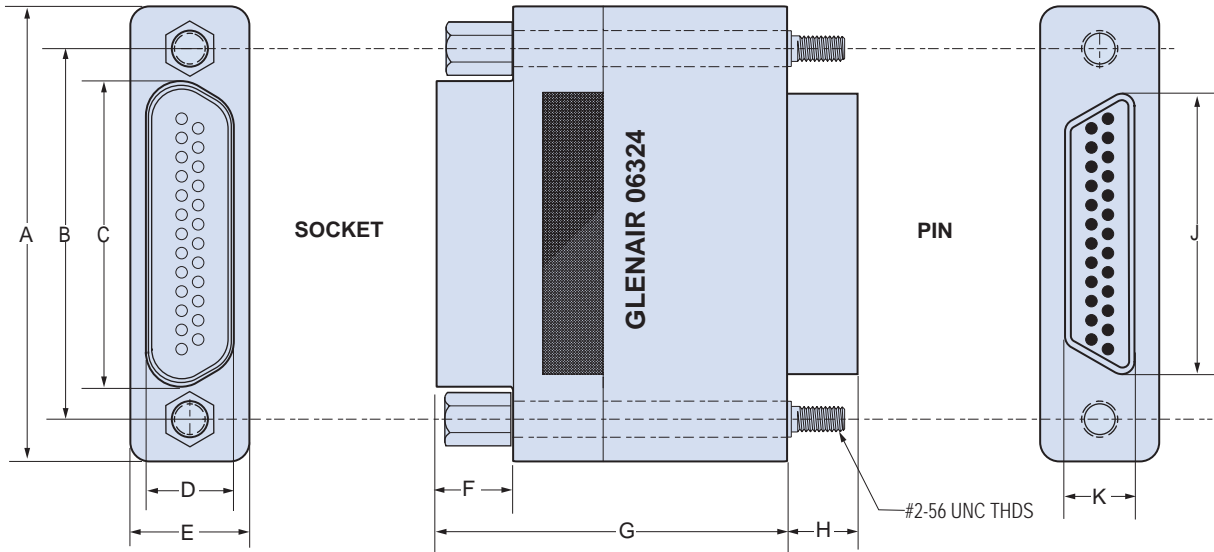

Layout	A Max.		B		C Max.		D Max.		E Max.		F		G Max.		H		J Max.		K Max.	
	In.	mm.	In. ±.003	mm. ±0.08	In.	mm.	In.	mm.	In.	mm.	In. ±.004	mm. ±0.10	In.	mm.	In. ±.004	mm. ±0.10	In.	mm.	In.	mm.
9PS	.785	19.94	.565	14.35	.400	10.16	.250	6.35	.310	7.87	.195	4.95	1.400	35.56	.183	4.65	.333	8.46	.184	4.67
15PS	.935	23.75	.715	18.16	.531	14.00	.250	6.35	.310	7.87	.195	4.95	1.400	35.56	.183	4.65	.483	12.27	.184	4.67
21PS	1.085	27.56	.865	21.97	.701	17.81	.250	6.35	.310	7.87	.195	4.95	1.400	35.56	.183	4.65	.633	16.08	.184	4.67
25PS	1.185	30.10	.965	24.51	.801	20.35	.250	6.35	.310	7.87	.195	4.95	1.400	35.56	.183	4.65	.733	18.62	.184	4.67
31PS	1.335	33.91	1.115	28.32	.951	24.16	.250	6.35	.310	7.87	.195	4.95	1.400	35.56	.183	4.65	.883	22.43	.184	4.67
37PS	1.485	37.72	1.265	32.13	1.101	27.96	.250	6.35	.310	7.87	.195	4.95	1.400	35.56	.183	4.65	1.033	26.24	.184	4.67

Dimensions in inches (millimeters) and are subject to change without notice.

© 2013 Glenair, Inc.

U.S. CAGE Code 06324

Printed in U.S.A.

240-034 PCB Micro-D Filter Connectors Right Angle



Micro-D
MIL-DTL-83513 Type

Table II: Dimensions

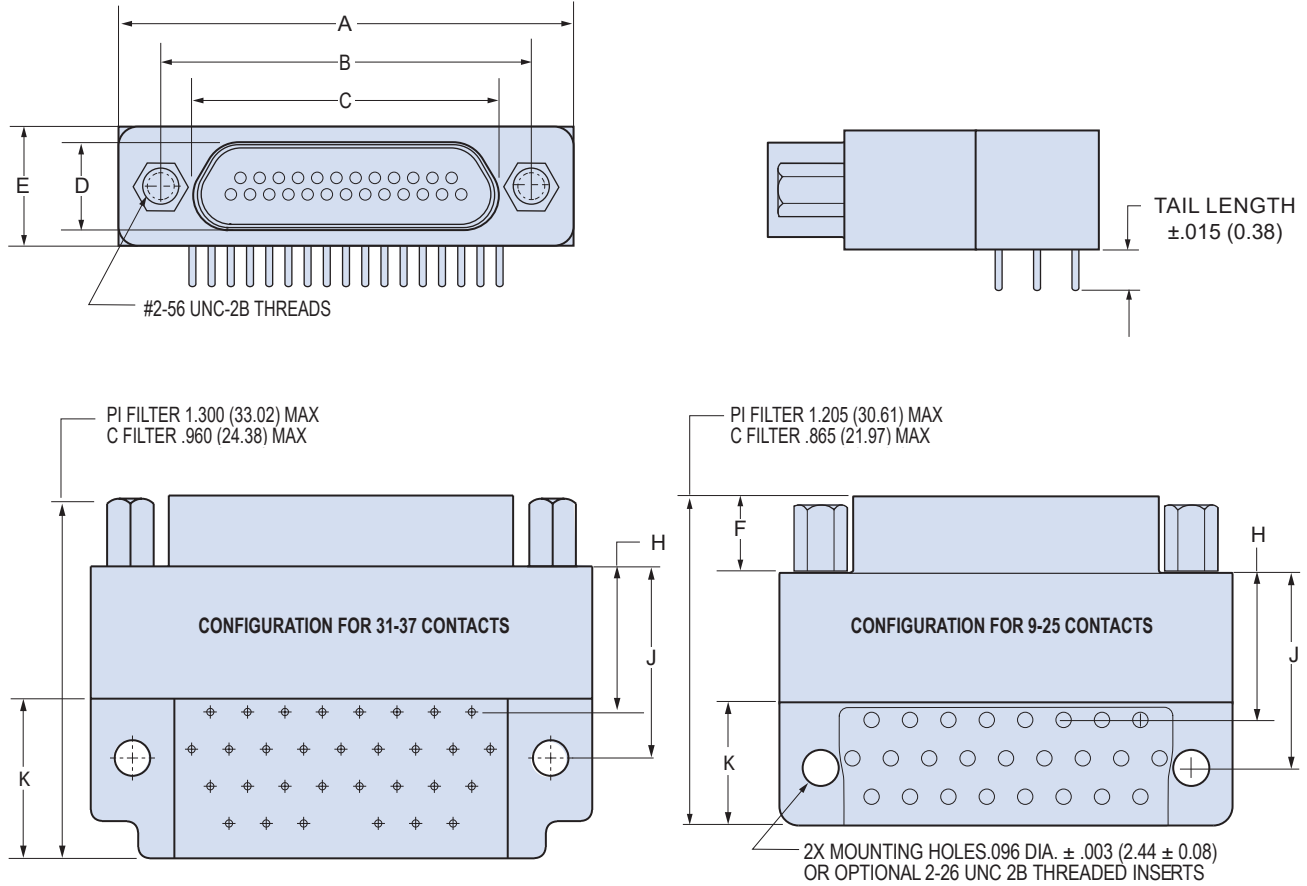

D

Layout	A Max.		B		C Max.		D Max.		E Max.		F		K Max.		C Filter				Pi Filter			
	In.	mm.	In.	mm.	In.	mm.	In.	mm.	In.	mm.	In.	mm.	In.	mm.	In.	mm.	In.	mm.	In.	mm.	In.	mm.
			$\pm .003$	± 0.08							$\pm .004$	± 0.10			$\pm .010$	± 0.25	$\pm .010$	± 0.25	$\pm .010$	± 0.25	$\pm .010$	± 0.25
9P	.785	19.94	.565	14.35	.333	8.46	.184	4.67	.310	7.87	.183	4.65	.335	8.51	.440	11.18	.460	11.68	.740	18.80	.760	19.30
9S	.785	19.94	.565	14.35	.400	10.16	.250	6.35	.310	7.87	.195	4.95	.335	8.51	.440	11.18	.460	11.68	.740	18.80	.760	19.30
15P	.935	23.75	.715	18.16	.483	12.27	.184	4.67	.310	7.87	.183	4.65	.335	8.51	.340	8.64	.460	11.68	.640	16.26	.760	19.30
15S	.935	23.75	.715	18.16	.551	14.00	.250	6.35	.310	7.87	.195	4.95	.335	8.51	.340	8.64	.460	11.68	.640	16.26	.760	19.30
21P	1.085	27.56	.865	21.97	.633	16.08	.184	4.67	.310	7.87	.183	4.65	.335	8.51	.340	8.64	.460	11.68	.640	16.26	.760	19.30
21S	1.085	27.56	.865	21.97	.701	17.81	.250	6.35	.310	7.87	.195	4.95	.335	8.51	.340	8.64	.460	11.68	.640	16.26	.760	19.30
25P	1.185	30.10	.965	24.51	.733	18.62	.184	4.67	.310	7.87	.183	4.65	.335	8.51	.340	8.64	.460	11.68	.640	16.26	.760	19.30
25S	1.185	30.10	.965	24.51	.801	20.35	.250	6.35	.310	7.87	.195	4.95	.335	8.51	.340	8.64	.460	11.68	.640	16.26	.760	19.30
31P	1.335	33.91	1.115	28.32	.883	22.43	.184	4.67	.310	7.87	.183	4.65	.430	10.92	.340	8.64	.460	11.68	.640	16.26	.760	19.30
31S	1.335	33.91	1.115	28.32	.951	24.16	.250	6.35	.310	7.87	.195	4.95	.430	10.92	.340	8.64	.460	11.68	.640	16.26	.760	19.30
37P	1.485	37.72	1.265	32.13	1.033	26.24	.184	4.67	.310	7.87	.183	4.65	.430	10.92	.340	8.64	.460	11.68	.640	16.26	.760	19.30
37S	1.485	37.72	1.265	32.13	1.101	27.96	.250	6.35	.310	7.87	.195	4.95	.430	10.92	.340	8.64	.460	11.68	.640	16.26	.760	19.30

Dimensions in inches (millimeters) and are subject to change without notice.

© 2013 Glenair, Inc.

U.S. CAGE Code 06324

Printed in U.S.A.



240-034
PCB Micro-D Filter Connectors
Right Angle

Micro-D Jackpost options

NN/NU	PN/PU	R2U Thru R6U
<p>HEX NUT EPOXY FILL</p>		<p>Panel</p>
<p>Thru-Hole: For use with Glenair jackposts only. Order hardware separately. Install w/ threadlocking compound.</p>	<p>Standard Jackpost: Factory installed, not intended for removal.</p>	<p>Jackpost for Rear Panel Mounting: Shipped loosely installed. Install w/ permanent threadlocking compound.</p>

Micro-D Filter Right Angle PCB Layouts — Pin Connector

PC Tail Diameter $.018 \pm .002$ (0.46 ± 0.05)

Contact numbers shown are for pin connectors.

Patterns shown are for connector mounting side of PC board.

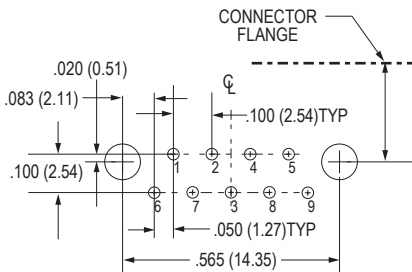

9 CONTACTS

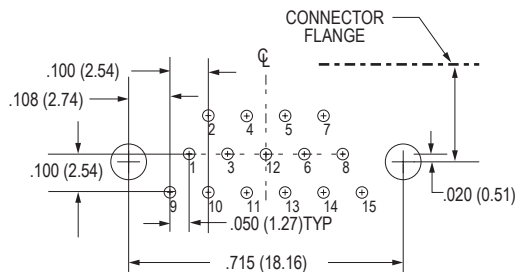

15 CONTACTS

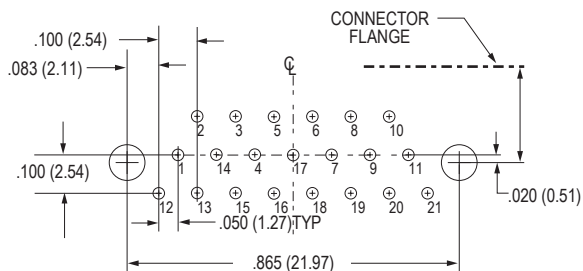

21 CONTACTS

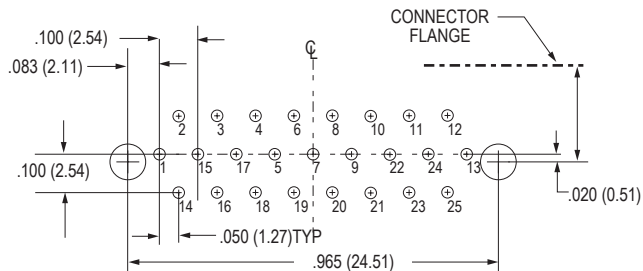

25 CONTACTS

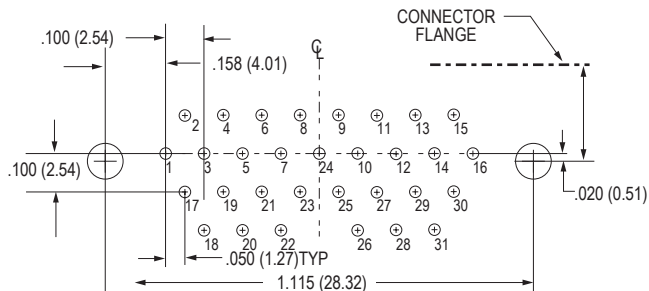

31 CONTACTS

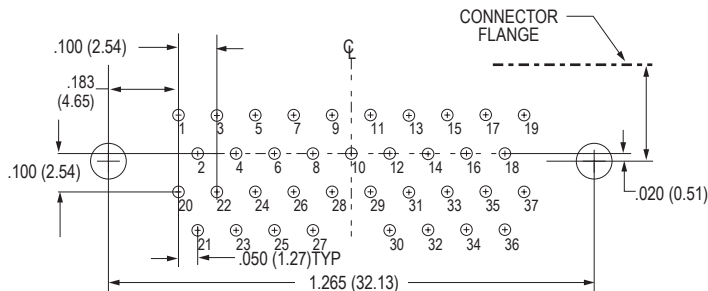

37 CONTACTS

Dimensions in inches (millimeters) and are subject to change without notice.

240-034 PCB Micro-D Filter Connectors Right Angle



Micro-D
MIL-DTL-83513 Type

Micro-D Filter Right Angle PCB Layouts — Socket Connector

PC Tail Diameter $.018 \pm .002$ (0.46 ± 0.05)
 Contact numbers shown are for socket connectors.
 Patterns shown are for connector mounting side of PC board.

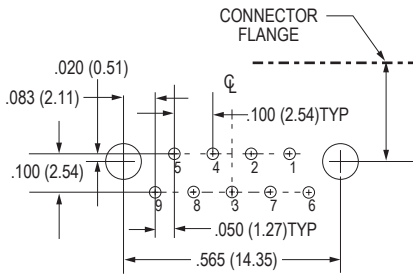

9 CONTACTS

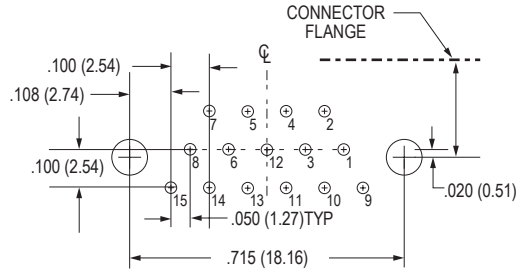

15 CONTACTS

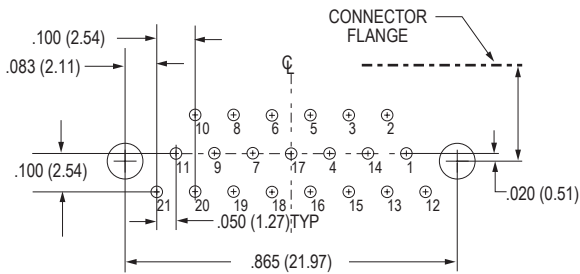

21 CONTACTS

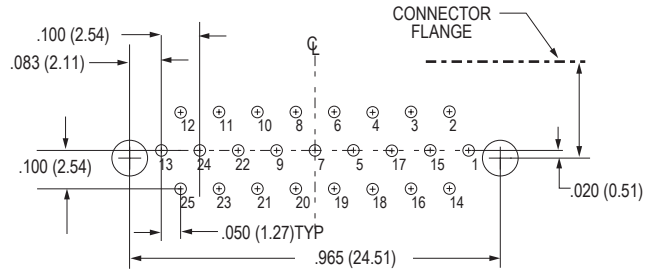

25 CONTACTS

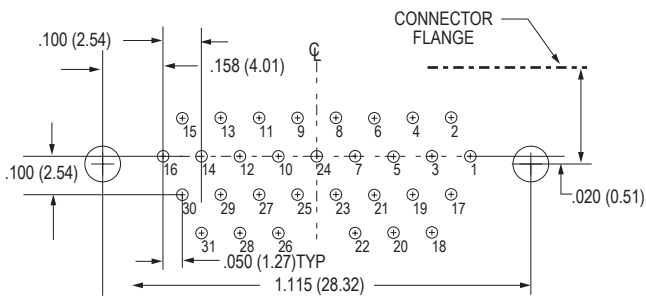

31 CONTACTS

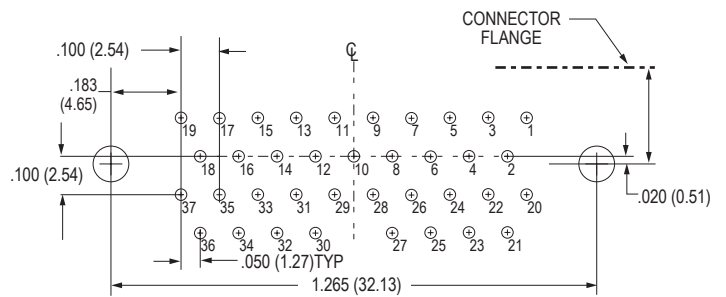

37 CONTACTS

Dimensions in inches (millimeters) and are subject to change without notice.

D

240-075 Rear Panel Mount Micro-D Filter Connectors Solder Cup



Micro-D
MIL-DTL-83513 Type

Table II: Dimensions

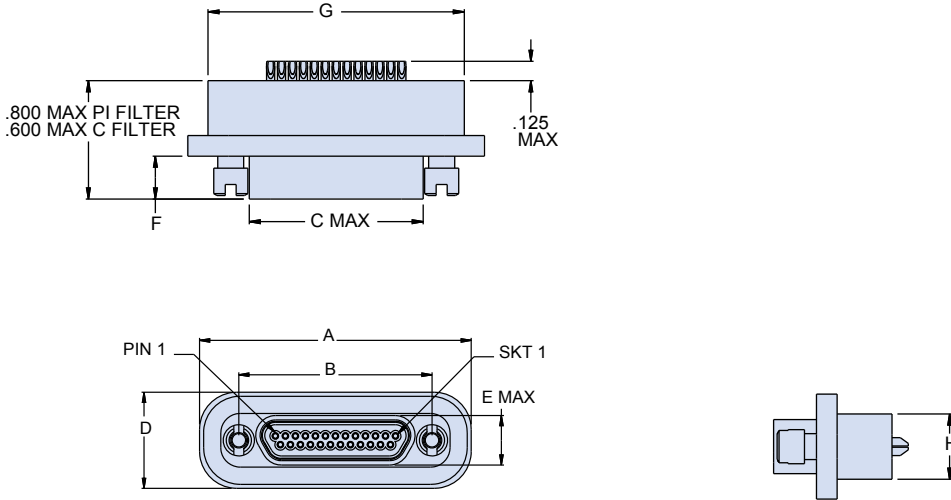

D

Shell Size	A ±.005		B ±.003		C Max		D ±.005		E Max		F ±.003		G ±.005		H Max	
	in.	mm	in.	mm	in.	mm	in.	mm	in.	mm	in.	mm	in.	mm	in.	mm
9P	0.960	0.960	0.565	14.35	0.334	8.48	0.480	12.19	0.184	4.67	0.183	4.65	.790	20.07	0.310	7.87
9S	0.960	0.960	0.565	14.35	0.400	10.16	0.480	12.19	0.250	6.35	0.195	4.95	.790	20.07	0.310	7.87
15P	1.110	1.110	0.715	18.16	0.484	12.29	0.480	12.19	0.184	4.67	0.183	4.65	.940	23.88	0.310	7.87
15S	1.110	1.110	0.715	18.16	0.550	13.97	0.480	12.19	0.250	6.35	0.195	4.95	.940	23.88	0.310	7.87
21P	1.260	1.260	0.865	21.97	0.634	16.10	0.480	12.19	0.184	4.67	0.183	4.65	1.090	27.69	0.310	7.87
21S	1.260	1.260	0.865	21.97	0.700	17.78	0.480	12.19	0.250	6.35	0.195	4.95	1.090	27.69	0.310	7.87
25P	1.360	1.360	0.965	24.51	0.734	18.64	0.480	12.19	0.184	4.67	0.183	4.65	1.190	30.23	0.310	7.87
25S	1.360	1.360	0.965	24.51	0.800	20.32	0.480	12.19	0.250	6.35	0.195	4.95	1.190	30.23	0.310	7.87
31P	1.510	1.510	1.115	28.32	0.884	22.45	0.480	12.19	0.184	4.67	0.183	4.65	1.340	34.04	0.310	7.87
31S	1.510	1.510	1.115	28.32	0.950	24.13	0.480	12.19	0.250	6.35	0.195	4.95	1.340	34.04	0.310	7.87
37P	1.660	1.660	1.265	32.13	1.034	26.26	0.480	12.19	0.184	4.67	0.183	4.65	1.490	37.85	0.310	7.87
37S	1.660	1.660	1.265	32.13	1.100	27.94	0.480	12.19	0.250	6.35	0.195	4.95	1.490	37.85	0.310	7.87

Notes

- Mounting holes fitted with 2x .086-56 threaded insert, .15 min thread. (T3585-02CPF129).
- Ground spring not available on cadmium plated assemblies.
- Interface dimensions per MIL-DTL-83513.
- Electrical performance:
I.R.: 5000 Megohms min at 100 VDC
D.W.V.: 200 VDC
- Assembly to be identified with Glenair's name, part number, date code, and pin 1 identification.

Materials / Finishes:

- Shell - Aluminum Alloy/See Chart
- Insulator - LCP/NA
- Contacts - Copper Alloy/Gold Plated
- Ground Spring - Stainless Steel/Gold Plated
- Socket Interfacial Seal: Fluorosilicone

Dimensions in inches (millimeters) and are subject to change without notice.

240-076 PCB Rear Panel Mount Micro-D Filter Connectors Vertical Mount Style



Micro-D
MIL-DTL-83513 Type

Table II: Dimensions



D

Shell Size	A ±.005		B ±.003		C Max		D ±.005		E Max		F ±.003		G ±.005		H Max	
	in.	mm	in.	mm	in.	mm	in.	mm	in.	mm	in.	mm	in.	mm	in.	mm
9P	0.960	24.38	0.565	14.35	0.334	364.52	0.480	12.19	0.184	4.67	0.183	4.65	.790	20.07	0.310	7.87
9S	0.960	24.38	0.565	14.35	0.400	364.52	0.480	12.19	0.250	6.35	0.195	4.95	.790	20.07	0.310	7.87
15P	1.110	28.19	0.715	18.16	0.484	461.29	0.480	12.19	0.184	4.67	0.183	4.65	.940	23.88	0.310	7.87
15S	1.110	28.19	0.715	18.16	0.550	461.29	0.480	12.19	0.250	6.35	0.195	4.95	.940	23.88	0.310	7.87
21P	1.260	32.00	0.865	21.97	0.634	558.06	0.480	12.19	0.184	4.67	0.183	4.65	1.090	27.69	0.310	7.87
21S	1.260	32.00	0.865	21.97	0.700	558.06	0.480	12.19	0.250	6.35	0.195	4.95	1.090	27.69	0.310	7.87
25P	1.360	34.54	0.965	24.51	0.734	622.58	0.480	12.19	0.184	4.67	0.183	4.65	1.190	30.23	0.310	7.87
25S	1.360	34.54	0.965	24.51	0.800	622.58	0.480	12.19	0.250	6.35	0.195	4.95	1.190	30.23	0.310	7.87
31P	1.510	38.35	1.115	28.32	0.884	719.35	0.480	12.19	0.184	4.67	0.183	4.65	1.340	34.04	0.310	7.87
31S	1.510	38.35	1.115	28.32	0.950	719.35	0.480	12.19	0.250	6.35	0.195	4.95	1.340	34.04	0.310	7.87
37P	1.660	42.16	1.265	32.13	1.034	816.13	0.480	12.19	0.184	4.67	0.183	4.65	1.490	37.85	0.310	7.87
37S	1.660	42.16	1.265	32.13	1.100	816.13	0.480	12.19	0.250	6.35	0.195	4.95	1.490	37.85	0.310	7.87

Notes

- Mounting holes fitted with 2x .086-56 threaded insert, .15 min thread. (T3585-02CPF129).
- Ground spring not available on cadmium plated assemblies.
- Interface dimensions per MIL-DTL-83513.
- Electrical performance:
I.R.: 5000 Megohms min at 100 VDC
D.W.V.: 200 VDC
- Assembly to be identified with Glenair's name, part number, date code, and pin 1 identification.
- See 240-031 for PCB layout

Materials / Finishes:

- Shell - Aluminum Alloy/See Chart
- Insulator - LCP/NA
- Contacts - Copper Alloy/Gold Plated
- Ground Spring - Stainless Steel/Gold Plated
- Socket Interfacial Seal: Fluorosilicone

Dimensions in inches (millimeters) and are subject to change without notice.



240-077 Rear Panel Mount Micro-D Filter Connectors Insulated Wire

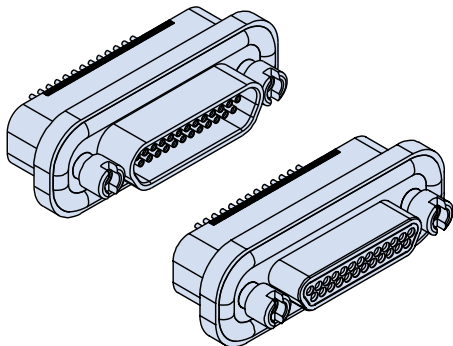

Glenair Filtered Insulated Wire Micro-D's provide EMI solutions in a miniaturized M83513 Micro-D connector. These connectors feature ceramic capacitor planar arrays and ferrite inductors. Insulated wire is factory precision-crimped to TwistPin contacts for superior reliability in the most demanding environments.

Choose Pi or C Filter Arrays in eight filter classes and six layouts. Glenair filtered Micro-D connectors comply with applicable MIL-DTL-83513 requirements and are 100% intermateable with standard connectors.

Choose 9 to 37 Contacts, with standard cadmium or nickel plating on the connector housing or choose optional finishes such as gold or chem film.

D

How To Order Rear Panel Mount Filter Connectors with Insulated Wire

Sample Part Number	240-077	-2	-25	S	C	F	-6	K	7	-18	R1	N	N
Series	240-077												
Shell Finish	Aluminum Shell 1 - Cadmium 2 - Nickel 5 - Gold 6 - Chem Film 33 - Nickel/PTFE												
Contact Layout	9, 15, 21, 25, 31, 37 (See Table II)												
Contact Type	P - Pin S - Socket												
Filter Type	C - C Filter P - Pi Filter												
Filter Class	A, B, C, D, E, F, G, J (See Table I)												
Wire Gauge	4 - 24 6 - 26 8 - 28 0 - 30												
Wire Type	K - M22759/11 J - M22759/33 E - NEMA HP3-EB (M16878/4)												
Wire Color/Type	1 - White 2 - Yellow 5 - Full Color 7 - 10 Color Repeat												
Wire Length	18 - 18 Inches												
Hardware Option	Rear Panel Mount Hardware Option (See Note 1) B - No Hardware R1 - 0.032" (0.8) Panel R2 - 0.047" (1.2) Panel R3 - 0.062" (1.6) Panel R4 - 0.093" (2.4) Panel R5 - 0.125" (3.2) Panel R6 - 0.080" (2.0) Panel												
Plug EMI Ground Spring	G - Ground spring installed N - No ground spring (N applies to all receptacle assemblies) (See Note 2)												
O-Ring	C - Conductive N - Non-Conductive (Nitrile)												

Table I: Micro-D Filter Classes and Performance

Filter Class	A	B	C	D	E	F	G	J
Capacitance (pF)								
C Filter	19000-28000	16000-22500	9000-16500	4000-6000	1650-2500	400-650	200-300	35-60
Pi Filter	38000-56000	32000-45000	18000-33000	8000-12000	3300-5000	800-1300	400-600	70-120

Dimensions in inches (millimeters) and are subject to change without notice.

Rev. Jun. 2 2014

© 2013 Glenair, Inc.

U.S. CAGE Code 06324

Printed in U.S.A.

240-077
Rear Panel Mount Micro-D Filter Connectors
Insulated Wire



Micro-D
MIL-DTL-83513 Type

Table II: Dimensions

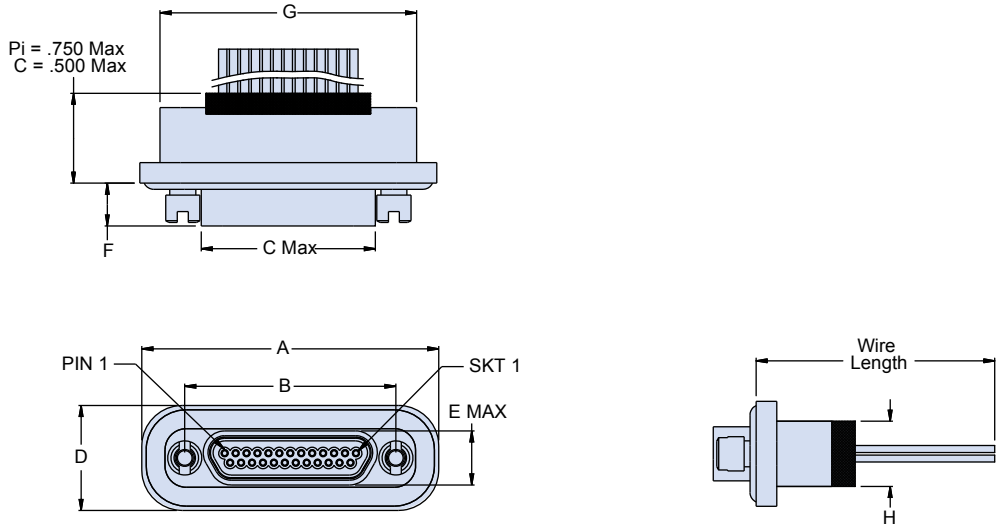

Shell Size	A ±.005		B ±.003		C Max		D ±.005		E Max		F ±.003		G ±.005		H Max	
	in.	mm	in.	mm	in.	mm	in.	mm	in.	mm	in.	mm	in.	mm	in.	mm
9P	0.960	24.38	0.565	14.35	0.334	8.48	0.480	12.19	0.184	4.67	0.183	4.65	.790	20.07	0.310	7.87
9S	0.960	24.38	0.565	14.35	0.400	10.16	0.480	12.19	0.250	6.35	0.195	4.95	.790	20.07	0.310	7.87
15P	1.110	28.19	0.715	18.16	0.484	12.29	0.480	12.19	0.184	4.67	0.183	4.65	.940	23.88	0.310	7.87
15S	1.110	28.19	0.715	18.16	0.550	13.97	0.480	12.19	0.250	6.35	0.195	4.95	.940	23.88	0.310	7.87
21P	1.260	32.00	0.865	21.97	0.634	16.10	0.480	12.19	0.184	4.67	0.183	4.65	1.090	27.69	0.310	7.87
21S	1.260	32.00	0.865	21.97	0.700	17.78	0.480	12.19	0.250	6.35	0.195	4.95	1.090	27.69	0.310	7.87
25P	1.360	34.54	0.965	24.51	0.734	18.64	0.480	12.19	0.184	4.67	0.183	4.65	1.190	30.23	0.310	7.87
25S	1.360	34.54	0.965	24.51	0.800	20.32	0.480	12.19	0.250	6.35	0.195	4.95	1.190	30.23	0.310	7.87
31P	1.510	38.35	1.115	28.32	0.884	22.45	0.480	12.19	0.184	4.67	0.183	4.65	1.340	34.04	0.310	7.87
31S	1.510	38.35	1.115	28.32	0.950	24.13	0.480	12.19	0.250	6.35	0.195	4.95	1.340	34.04	0.310	7.87
37P	1.660	42.16	1.265	32.13	1.034	26.26	0.480	12.19	0.184	4.67	0.183	4.65	1.490	37.85	0.310	7.87
37S	1.660	42.16	1.265	32.13	1.100	27.94	0.480	12.19	0.250	6.35	0.195	4.95	1.490	37.85	0.310	7.87

Notes

- Mounting holes fitted with 2x .086-56 threaded insert, .15 min thread. (T3585-02CPF129).
- Ground spring not available on cadmium plated assemblies.
- Interface dimensions per MIL-DTL-83513.
- Electrical performance:
 I.R.: 5000 Megohms min at 100 VDC
 D.W.V.: 200 VDC
- Assembly to be identified with Glenair's name, part number, date code, and pin 1 identification.

Materials / Finishes:

- Shell - Aluminum Alloy/See Chart
- Insulator - LCP/NA
- Contacts - Copper Alloy/Gold Plated
- Ground Spring - Stainless Steel/Gold Plated
- Socket Interfacial Seal: Fluorosilicone

Dimensions in inches (millimeters) and are subject to change without notice.



240-078 Rear Panel Mount Micro-D Filter Connectors Condensed Board Right Angle Type



Micro-D
MIL-DTL-83513 Type

Table II: Dimensional Table Dimensional Table

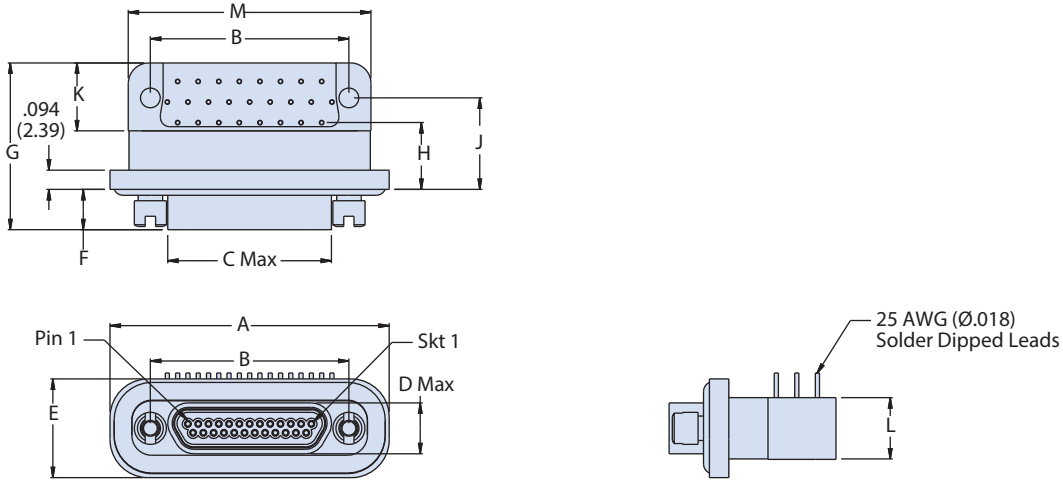

D

Shell Size	A MAX		B ± .003		C MAX		D MAX		E MAX		F ± .004		K MAX		L MAX		M MAX	
	in.	mm.	in.	mm.	in.	mm.	in.	mm.	in.	mm.	in.	mm.	in.	mm.	in.	mm.	in.	mm.
9P	0.965	24.51	0.565	14.35	0.333	8.46	0.184	4.67	0.485	12.32	0.183	4.65	0.335	8.51	.310	7.87	.790	20.07
9S	0.965	24.51	0.565	14.35	0.400	10.16	0.250	6.35	0.485	12.32	0.195	4.95	0.335	8.51	.310	7.87	.790	20.07
15P	1.115	28.32	0.715	18.16	0.483	12.27	0.184	4.67	0.485	12.32	0.183	4.65	0.335	8.51	.310	7.87	.940	23.88
15S	1.115	28.32	0.715	18.16	0.551	14.00	0.250	6.35	0.485	12.32	0.195	4.95	0.335	8.51	.310	7.87	.940	23.88
21P	1.265	32.13	0.865	21.97	0.633	16.08	0.184	4.67	0.485	12.32	0.183	4.65	0.335	8.51	.310	7.87	1.090	27.69
21S	1.265	32.13	0.865	21.97	0.701	17.81	0.250	6.35	0.485	12.32	0.195	4.95	0.335	8.51	.310	7.87	1.090	27.69
25P	1.365	34.67	0.965	24.51	0.733	18.62	0.184	4.67	0.485	12.32	0.183	4.65	0.335	8.51	.310	7.87	1.190	30.23
25S	1.365	34.67	0.965	24.51	0.801	20.35	0.250	6.35	0.485	12.32	0.195	4.95	0.335	8.51	.310	7.87	1.190	30.23
31P	1.515	38.48	1.115	28.32	0.883	22.43	0.184	4.67	0.485	12.32	0.183	4.65	0.430	10.92	.310	7.87	1.340	34.04
31S	1.515	38.48	1.115	28.32	0.951	24.16	0.250	6.35	0.485	12.32	0.195	4.95	0.430	10.92	.310	7.87	1.340	34.04
37P	1.665	42.29	1.265	32.13	1.033	26.24	0.184	4.67	0.485	12.32	0.183	4.65	0.430	10.92	.310	7.87	1.490	37.85
37S	1.665	42.29	1.265	32.13	1.101	27.97	0.250	6.35	0.485	12.32	0.195	4.95	0.430	10.92	.310	7.87	1.490	37.85
51P	1.665	42.29	1.215	30.86	1.033	26.24	0.224	5.69	0.530	13.46	0.183	4.65	0.560	14.22	.394	10.01	1.440	36.58
51S	1.665	42.29	1.215	30.86	1.101	27.97	0.293	7.44	0.530	13.46	0.195	4.95	0.560	14.22	.394	10.01	1.440	36.58

Table I: Micro-D Filter Classes and Performance

Filter Class	A	B	C	D	E	F	G	J
Capacitance (pF)								
C Filter	19000-28000	16000-22500	9000-16500	4000-6000	1650-2500	400-650	200-300	35-60
Pi Filter	38000-56000	32000-45000	18000-33000	8000-12000	3300-5000	800-1300	400-600	70-120

Notes

- Mounting holes fitted with 2x .086-56 threaded insert, .15 min thread. (T3585-02CPF129).
- Ground spring not available on cadmium plated assemblies.
- Interface dimensions per MIL-DTL-83513.
- Electrical performance:
I.R.: 5000 Megohms min at 100 VDC
D.W.V.: 200 VDC
- Assembly to be identified with Glenair's name, part number, date code, and pin 1 identification.
- See 240-034 for PCB layout

Materials / Finishes:

- Shell - Aluminum Alloy/See Chart
- Insulator - LCP/NA
- Contacts - Copper Alloy/Gold Plated
- Ground Spring - Stainless Steel/Gold Plated
- Socket Interfacial Seal: Fluorosilicone

Dimensions in inches (millimeters) and are subject to change without notice.

Rev. June 13, 2017

© 2013 Glenair, Inc.

U.S. CAGE Code 06324

Printed in U.S.A.

GLENAIR, INC. • 1211 AIR WAY • GLENDALE, CA 91201-2497 • 818-247-6000 • FAX 818-500-9912
www.glenair.com **D-29** **E-Mail: sales@glenair.com**

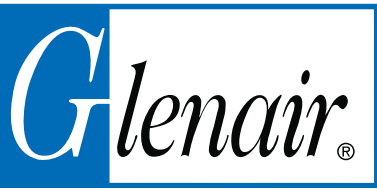

247-379 Edge Board Micro-D Filter Connector

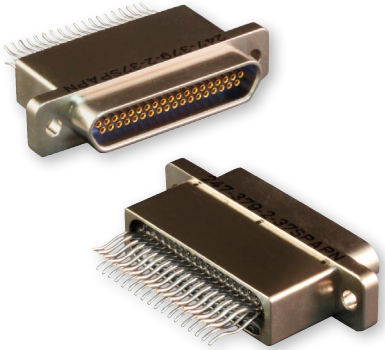

Glenair Edge Board Micro-D Filter Connectors provide EMI solutions in a miniaturized M83513 Micro-D connector. These connectors feature ceramic capacitor planar arrays and ferrite inductors.

Choose Pi or C Filter Arrays in eight filter classes and six layouts. Glenair filtered Micro-D connectors comply with applicable MIL-DTL-83513 requirements and are 100% intermateable with standard connectors.

Choose 9 to 37 Contacts, with standard cadmium or nickel plating on the connector housing or choose optional finishes such as gold or chem film.

D

How To Order Edge Board Micro-D Filter Connector							
Sample Part Number	247-379	-2	-21	P	C	A	PN
Series	247-379						
Shell Finish	Aluminum Shell 1 - Cadmium 2 - Electroless Nickel 5 - Gold						
Contact Layout	9, 15, 21, 25, 31, 37 (See Table II)						
Contact Type	P - Pin S - Socket						
Filter Type	C - C Filter P - Pi Filter N - No Filter						
Filter Class	A, B, C, D, E, F, G, N, J (See Table I)						
Hardware Option (See Note 1)	NN - No Jackpost, No Threaded Insert PN - Jackpost, No Threaded Insert NU - Threaded Insert Only, No Jackpost (see Table III)		Rear Panel Mount Jackpost: R2U - 0.031" (0.6) Panel R3U - 0.047" (1.2) Panel R4U - 0.062" (1.6) Panel R5U - 0.094" (2.4) Panel R6U - 0.125" (3.2) Panel			Jackscrew Option: M - Hex Head Jackscrews S - Slot Head Jackscrews (see Table IV)	

Table I: Micro-D Filter Classes and Performance								
Filter Class	A	B	C	D	E	F	G	J
Capacitance (pF)								
C Filter	19000-28000	16000-22500	9000-16500	4000-6000	1650-2500	400-650	200-300	35-60
Pi Filter	38000-56000	32000-45000	18000-33000	8000-12000	3300-5000	800-1300	400-600	70-120

Notes

- PC tail configuration intended for use with .062 board thickness
- Electrical Performance:
 - Insulation Resistance: 5000 megohms Min at 100 VDC
 - Dielectric Withstanding Voltage: 200 VDC

Materials / Finishes:

- Shell - Aluminum Alloy/See Chart
- Insulator - LCP/NA
- Contacts - Copper Alloy/Gold Plated
- Ground Spring - Stainless Steel/Gold Plated
- Socket Interfacial Seal: Fluorosilicone

Dimensions in inches (millimeters) and are subject to change without notice.

Rev. Jun. 2 2014

© 2013 Glenair, Inc.

U.S. CAGE Code 06324

Printed in U.S.A.

247-379 Edge Board Micro-D Filter Connector



Micro-D
MIL-DTL-83513 Type

Table II: Dimensions

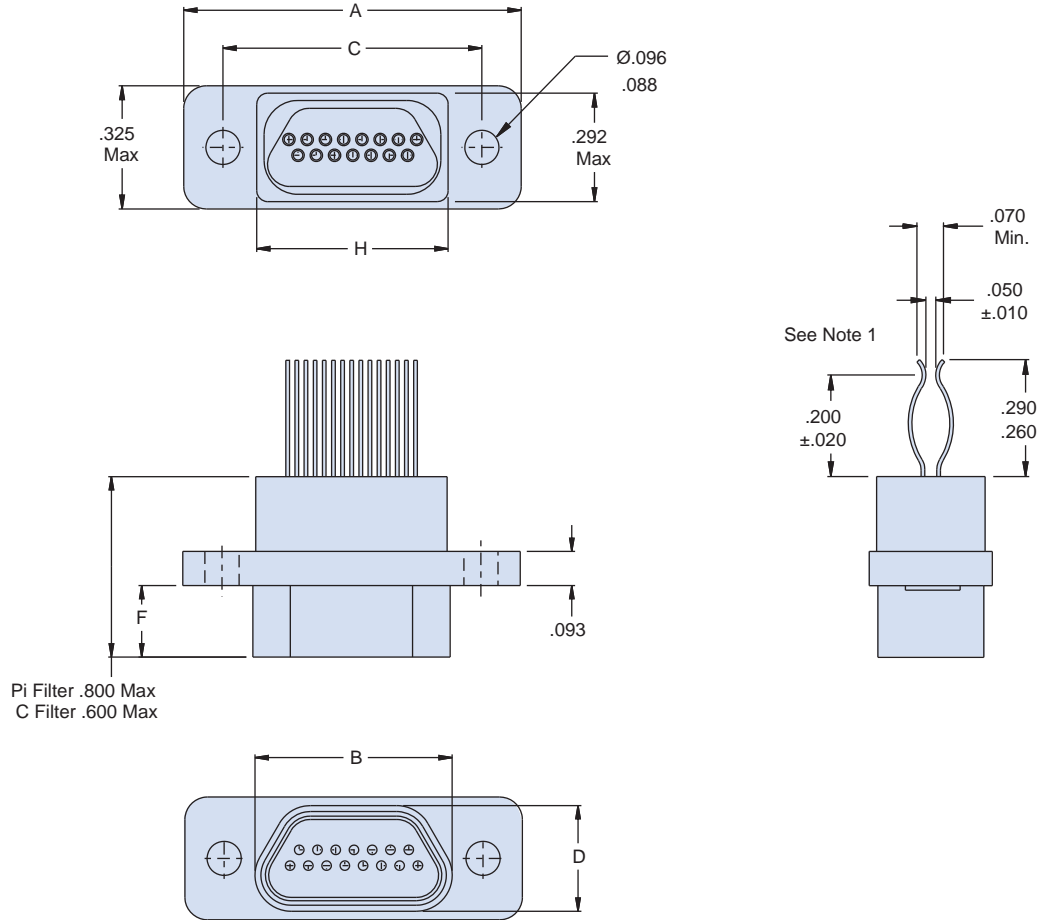

D

Shell Size	A ±.010		B Max		C ±.003		D Max		F ±.004		H Max	
	in.	mm	in.	mm	in.	mm	in.	mm	in.	mm	in.	mm
9P	0.785	19.94	0.333	8.46	0.565	14.35	0.184	4.67	0.183	4.65	0.400	10.16
9S	0.785	19.94	0.400	10.16	0.565	14.35	0.250	6.35	0.195	4.95	0.400	10.16
15P	0.935	23.75	0.483	12.27	0.715	18.16	0.184	4.67	0.183	4.65	0.550	13.97
15S	0.935	23.75	0.551	14.00	0.715	18.16	0.250	6.35	0.195	4.95	0.550	13.97
21P	1.085	27.56	0.633	16.08	0.865	21.97	0.184	4.67	0.183	4.65	0.700	17.78
21S	1.085	27.56	0.701	17.81	0.865	21.97	0.250	6.35	0.195	4.95	0.700	17.78
25P	1.185	30.10	0.733	18.62	0.965	24.51	0.184	4.67	0.183	4.65	0.800	20.32
25S	1.185	30.10	0.801	20.35	0.965	24.51	0.250	6.35	0.195	4.95	0.800	20.32
31P	1.335	33.91	0.883	22.43	1.115	28.32	0.184	4.67	0.183	4.65	0.950	24.13
31S	1.335	33.91	0.951	24.16	1.115	28.32	0.250	6.35	0.195	4.95	0.950	24.13
37P	1.485	37.72	1.033	26.24	1.265	32.13	0.184	4.67	0.183	4.65	1.100	27.94
37S	1.485	37.72	1.101	27.97	1.265	32.13	0.250	6.35	0.195	4.95	1.100	27.94

Dimensions in inches (millimeters) and are subject to change without notice.

© 2013 Glenair, Inc.

U.S. CAGE Code 06324

Printed in U.S.A.



247-379 Edge Board Micro-D Filter Connector

Micro-D Filtered Edge Board Connector - Pin

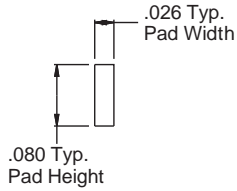

Pad Height and Width

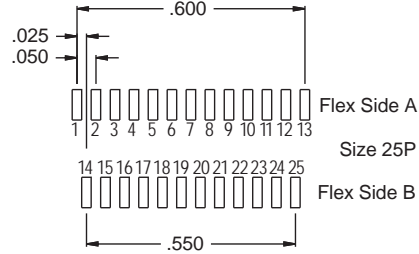

Size 25P

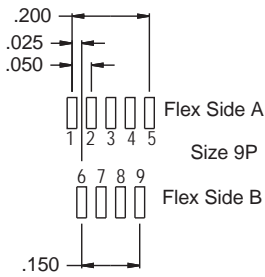

Size 9P

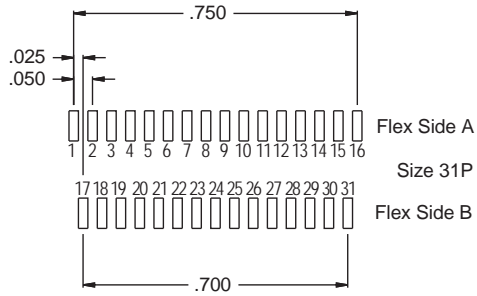

Size 31P

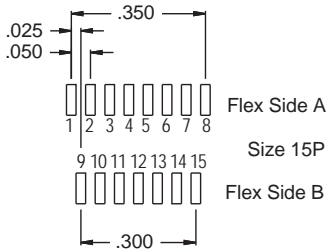

Size 15P

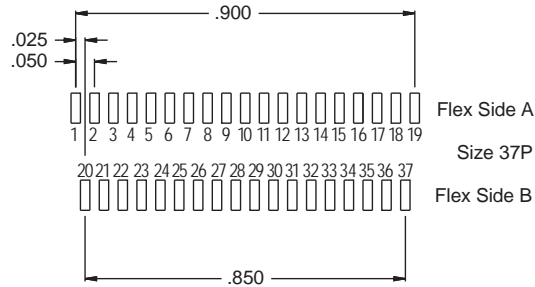

Size 37P

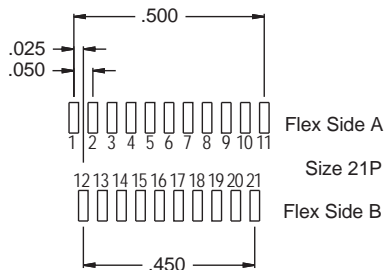

Size 21P

Dimensions in inches (millimeters) and are subject to change without notice.

247-379 Edge Board Micro-D Filter Connector



Micro-D
MIL-DTL-83513 Type

Micro-D Filtered Edge Board Connector - Socket

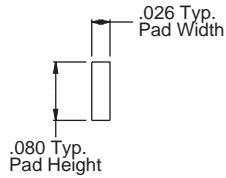

Pad Height and Width

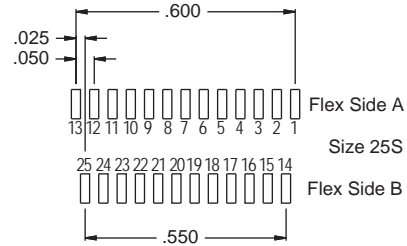

Size 25S

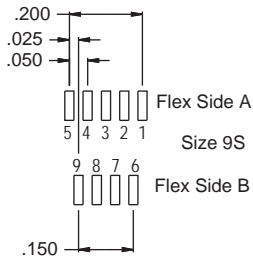

Size 9S

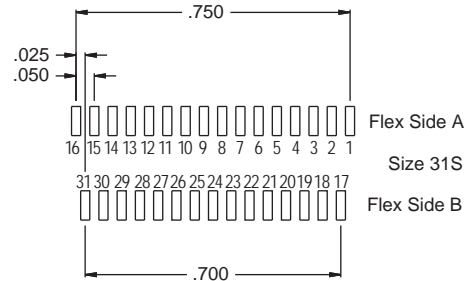

Size 31S

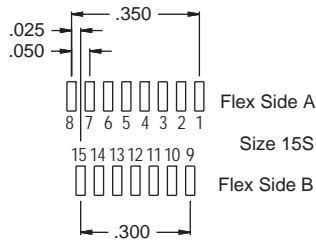

Size 15S

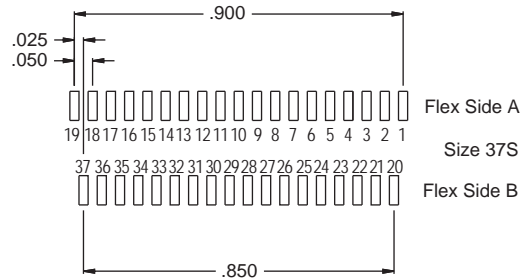

Size 37PS

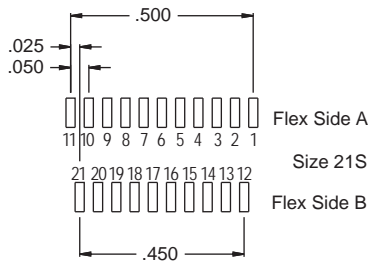

Size 21S

Dimensions in inches (millimeters) and are subject to change without notice.

D

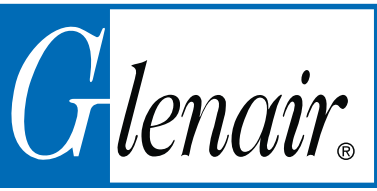

2470-1048 Combo Micro-D Filter Connector for Power Applications

2470-1048 Combo Micro-D Filter Connectors combine the size and weight advantages of a Micro-D connector with the added ability to handle higher power needs. Available in C filter configurations, with solder cup contact termination, PC tails or pre-wired.

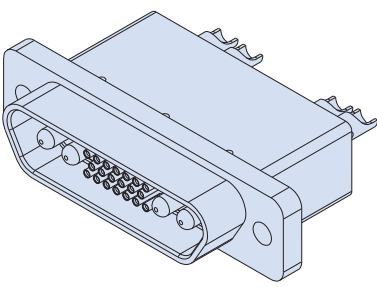

D

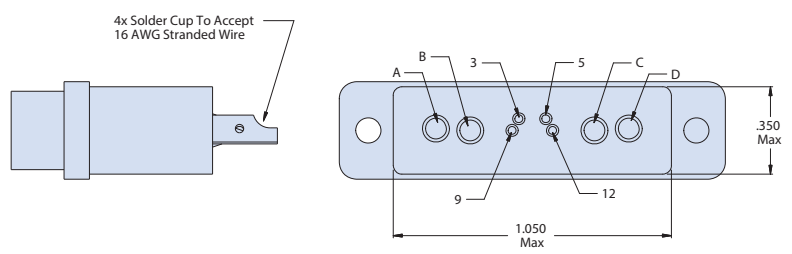
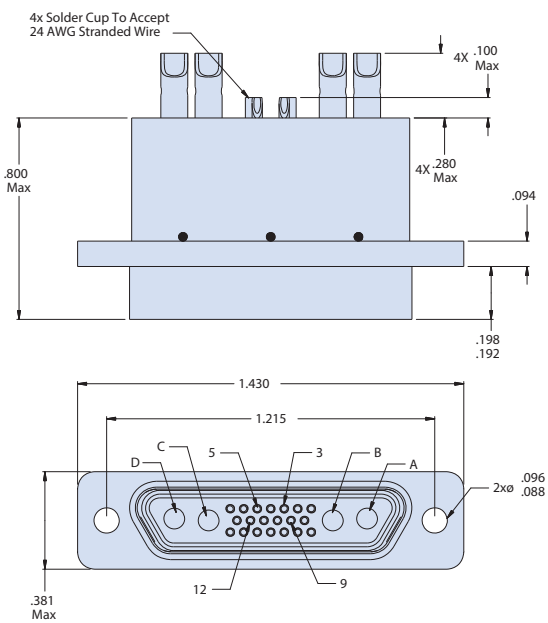

Notes

- Electrical Performance:
 - Insulation Resistance: 5000 megohms Min at 100 VDC
 - Dielectric Withstand Voltage: 250 VDC
 - Capacitance: pins A, B, C, D, 3, 5, 9 and 12 to be 38–56 nF Pi filter (filter class A). All remaining signal lines are fitted with dummy contacts with no termination.
 - Signal current rating: 3 Amps Max
 - Power current rating: 7.5 Amps Max
- Assembly to be identified with Glenair's name, part number and date code space permitting.

Materials / Finishes:

- Shell - Aluminum Alloy/See Chart
- Insulator - LCP/NA
- Contacts - Copper Alloy/Gold Plated
- Ground Spring - Stainless Steel/Gold Plated
- Socket Interfacial Seal: Fluorosilicone

Dimensions in inches (millimeters) and are subject to change without notice.

249-EMITS-MICRO EMITS EMI Troubleshooter Micro-D Edition



Micro-D
MIL-DTL-83513 Type

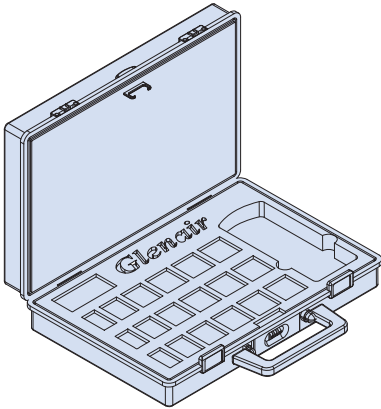

EMITS is designed for fast troubleshooting of EMI issues. Reduce time and money spent at test labs debugging EMI problems with this portable kit. Lightweight, high-strength anodized aluminum case comes supplied with low, medium, and high capacitance filters in size 9 through 37 position Micro-Ds, and a hand-held LCR meter.

How To Order EMITS		
Sample Part Number	249-EMITS-MICRO	-2
Series	249-EMITS-MICRO	
Plating	2 - Aluminum / Electroless Nickel	
	5 - Aluminum / Gold	

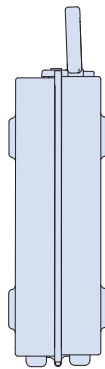
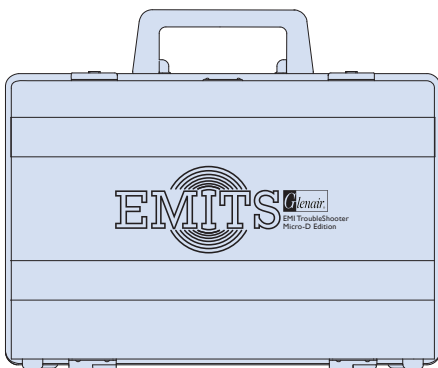
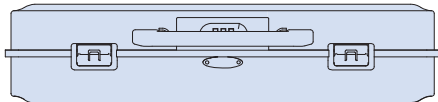
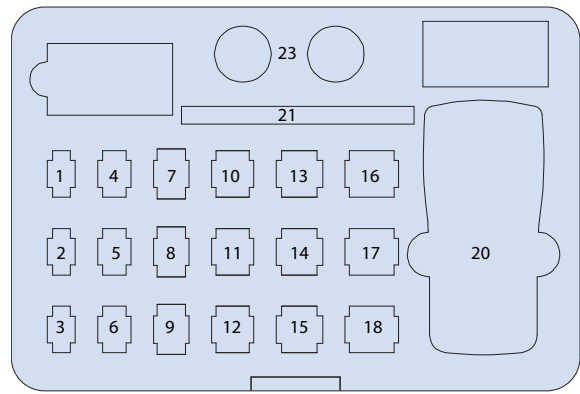

EMITS Kit Key		
Item	Part Number*	Description
1	240-033-X-9PSCEN	Filter Adapter, 9 Contacts, C Filter, Class E
2	240-033-X-9PSCAN	Filter Adapter, 9 Contacts, C Filter, Class A
3	240-033-X-9PSPAN	Filter Adapter, 9 Contacts, Pi Filter, Class A
4	240-033-X-15PSCEN	Filter Adapter, 15 Contacts, C Filter, Class E
5	240-033-X-15PSCAN	Filter Adapter, 15 Contacts, C Filter, Class A
6	240-033-X-15PSPAN	Filter Adapter, 15 Contacts, Pi Filter, Class A
7	240-033-X-21PSCEN	Filter Adapter, 21 Contacts, C Filter, Class E
8	240-033-X-21PSCAN	Filter Adapter, 21 Contacts, C Filter, Class A
9	240-033-X-21PSPAN	Filter Adapter, 21 Contacts, Pi Filter, Class A
10	240-033-X-25PSCEN	Filter Adapter, 25 Contacts, C Filter, Class E
11	240-033-X-25PSCAN	Filter Adapter, 25 Contacts, C Filter, Class A
12	240-033-X-25PSPAN	Filter Adapter, 25 Contacts, Pi Filter, Class A
13	240-033-X-31PSCEN	Filter Adapter, 31 Contacts, C Filter, Class E
14	240-033-X-31PSCAN	Filter Adapter, 31 Contacts, C Filter, Class A
15	240-033-X-31PSPAN	Filter Adapter, 31 Contacts, Pi Filter, Class A
16	240-033-X-37PSCEN	Filter Adapter, 37 Contacts, C Filter, Class E
17	240-033-X-37PSCAN	Filter Adapter, 37 Contacts, C Filter, Class A
18	240-033-X-37PSPAN	Filter Adapter, 37 Contacts, Pi Filter, Class A
20	U1733C LCR METER	Hand-Held LCR Meter
21	7278A35	Nutdriver Tool
23	249-033	Jackscrew/Jackpost sets with E-Rings (18)

* See 240-033 for filter connector details

Dimensions in inches (millimeters) and are subject to change without notice.

© 2013 Glenair, Inc.

U.S. CAGE Code 06324

Printed in U.S.A.

SERIES 240



M24308 Type D-Sub and HiPer-D Filter Connectors

MIL-DTL-24308 intermateable filter connectors with advanced environmental/shielding performance



The Glenair Series 28 HiPer-D connector is intermateable and intermountable with standard M24308 type D-Subs, and meets the need for improved performance in hostile environments. Unlike standard M24308 connectors with stamped steel shells, the HiPer-D is precision-machined from aluminum or stainless steel. The dielectric inserts are made with thermoset epoxy for improved resistance to chemicals and are capable of withstanding 200°C continuous operating temperature. Aerospace-grade fluorosilicone grommets and face seals provide watertight sealing. Integrated grounding fingers provide superior electromagnetic compatibility. Best of all, the HiPer-D is available in every standard and high-density M24308 layout as well as combo layouts integrating power and shielded contacts. Like all Glenair high-performance solutions, HiPer-D is stocked for immediate same-day shipment.



Glenair, Inc.
1211 Air Way
Glendale, CA
91201-2497
818-247-6000
sales@glenair.com
www.glenair.com

M24308 Type D-Sub and HiPer-D Filter Connectors



D-Subminiature
MIL-DTL-24308 Type

Product Selection Guide

240-021
Page E-2

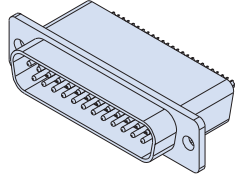

D-Sub Filter Connector with Straight Solder Cups or PC Tails

240-066
Page E-6

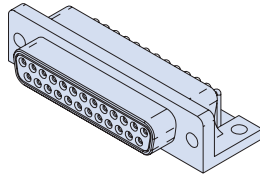

D-Sub Filter Connector with Right-Angle PC Tails

240-051
Page E-10

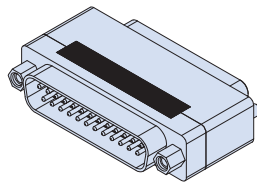

D-Sub Filter Connector Saver

240-083
Page E-12

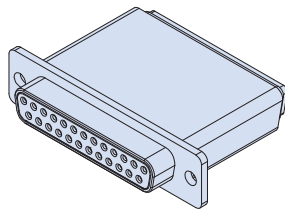

HiPer-D Filter Connector with Crimp Contacts

2470-1112
Page E-14

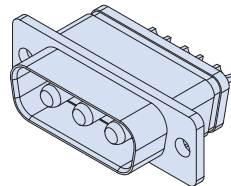

Combo-D Filter Plug Connector

240-EMITS-DSUB
Page E-15

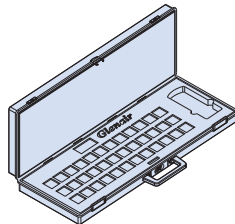

EMI Troubleshooter Kit for D-Sub Connectors

Dimensions in inches (millimeters) and are subject to change without notice.

© 2013 Glenair, Inc.

U.S. CAGE Code 06324

Printed in U.S.A.

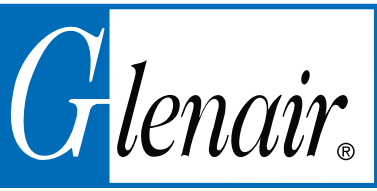

240-021

D-Subminiature Filter Connector Solder Cup / Straight PCB Contacts

How To Order Filter D-Subminiature Connectors									
Sample Part Number	240-021	S	-15	S-	JF	P	G	B	-S
Series	240-021								
Contact Density	S - Standard H - High								
Number of Contacts	9, 15, 25, 26, 37, 44, 50, 62, 78, 104 (See Table II)								
Contact Type	P - Pin S - Socket (See Table I)								
Shell Material/Finish	Aluminum Shell ME - Electroless Nickel JF - Yellow Cadmium MT - Nickel-PTFE Z2 - Gold E - Chem Film			Brass Shell GS - Gold					
Filter Type	C - C Filter P - Pi Filter (See Table I)								
Filter Class	A, B, C, D, E, F, G, J (See Table I)								
Hardware Options	B - No Hardware C - 4-40 Clinch Nut								
Termination Type	P - PC Tails S - Solder Cups								

E

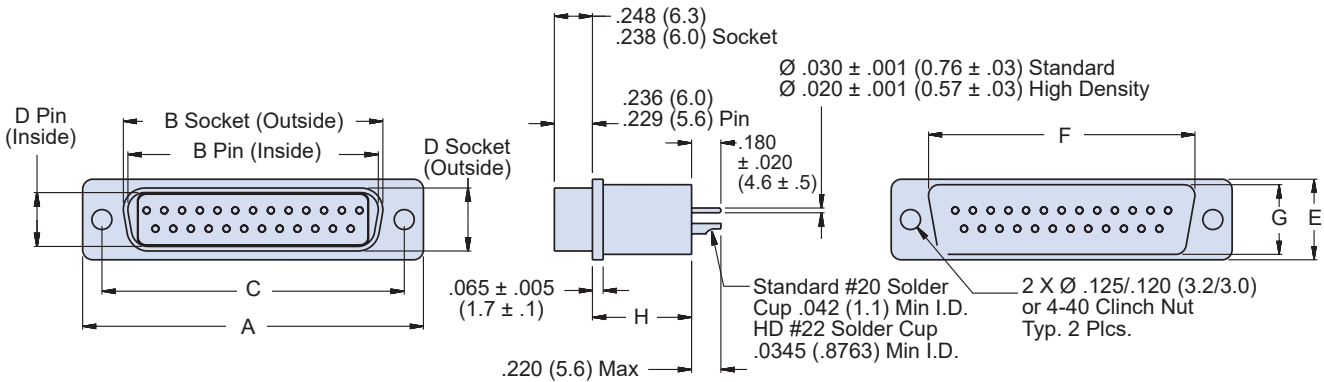

Class	Pi - Circuit (pF)	C - Circuit (pF)
A	38,000 - 56,000	19,000 - 28,000
B	32,000 - 45,000	16,000 - 22,500
C	18,000 - 33,000	9,000 - 16,500
D	8,000 - 12,000	4,000 - 6,000
E	3,300 - 5,000	1,650 - 2,500
F	800 - 1,300	400 - 650
G	400 - 600	200 - 300
J	70 - 120	35 - 60

Notes

1. Assembly to be identified with Glenair's name, part number, and date code space permitting
2. Electrical Performance:
 Dielectric Withstanding Voltage: 500 VDC
 Insulation Resistance: 5,000 megohms @ 200 VDC
 Current Rating Standard Density: 7.5 Amps max.
 Current Rating High Density: 5 Amps max.
3. Dimensions B and D taken from inside of shell for Pin/Plug and outside for Socket/ Receptacle

Materials/Finishes:

Insulators - High Grade Rigid Dielectric/N.A.
 Contacts - Copper Alloy/Gold Plated

Dimensions in inches (millimeters) and are subject to change without notice.

240-021

D-Subminiature Filter Connector Solder Cup / Straight PCB Contacts



D-Subminiature
MIL-DTL-24308 Type

Table II: Dimensions

Shell Size	Number of Contacts		A ±.015 (0.38)	B ±.005 (0.13)	C ±.005 (0.13)	D ±.005 (0.13)	E ±.015 (0.38)	F Max	G Max	H ± .010 (0.25)
	STD	HD								
1	9P	15P	1.213 (30.8)	.666 (16.9)	.984 (25.0)	.329 (8.4)	.494 (12.5)	.769 (19.5)	.432 (11.0)	Pi Filter = .610 (15.5) C Filter = .380 (9.7)
	9S	15S	1.213 (30.8)	.643 (16.3)	.984 (25.0)	.311 (7.9)	.494 (12.5)	.769 (19.5)	.432 (11.0)	
2	15P	26P	1.541 (39.1)	.994 (25.2)	1.312 (33.3)	.329 (8.4)	.494 (12.5)	1.093 (27.8)	.432 (11.0)	
	15S	26S	1.541 (39.1)	.971 (24.7)	1.312 (33.3)	.311 (7.9)	.494 (12.5)	1.093 (27.8)	.432 (11.0)	
3	25P	44P	2.088 (53.0)	1.534 (39.0)	1.852 (47.0)	.329 (8.4)	.494 (12.5)	1.635 (41.5)	.432 (11.0)	
	25S	44S	2.088 (53.0)	1.511 (38.4)	1.852 (47.0)	.311 (7.9)	.494 (12.5)	1.635 (41.5)	.432 (11.0)	
4	37P	62P	2.729 (69.3)	2.182 (55.4)	2.500 (63.5)	.329 (8.4)	.494 (12.5)	2.282 (58.0)	.432 (11.0)	
	37S	62S	2.729 (69.3)	2.159 (54.8)	2.500 (63.5)	.311 (7.9)	.494 (12.5)	2.282 (58.0)	.432 (11.0)	
5	50P	78P	2.635 (66.9)	2.079 (52.8)	2.406 (61.1)	.441 (11.2)	.605 (15.4)	2.188 (55.6)	.544 (13.8)	
	50S	78S	2.635 (66.9)	2.064 (52.4)	2.406 (61.1)	.423 (10.7)	.605 (15.4)	2.188 (55.6)	.544 (13.8)	
6	x	104P	2.729 (69.3)	2.212 (56.2)	2.500 (63.5)	.503 (12.8)	.668 (17.0)	2.312 (58.7)	.606 (15.4)	
		104S	2.729 (69.3)	2.189 (55.6)	2.500 (63.5)	.486 (12.3)	.668 (17.0)	2.312 (58.7)	.606 (15.4)	

E

Table III: Cut-Out Dimensions

Shell Size	V Min	W Bsc	X Min	Y Min	Z Min
1	.442 (11.2)	.984 (25.0)	.779 (19.8)	.396 (10.1)	.735 (18.7)
2	.442 (11.2)	1.312 (33.3)	1.110 (28.2)	.396 (10.1)	1.060 (26.9)
3	.442 (11.2)	1.852 (47.0)	1.649 (41.9)	.396 (10.1)	1.603 (40.7)
4	.442 (11.2)	2.500 (63.5)	2.296 (58.3)	.396 (10.1)	2.251 (57.2)
5	.554 (14.1)	2.406 (61.1)	2.198 (55.8)	.510 (13.0)	2.148 (54.6)
6	.616 (15.6)	2.500 (63.5)	2.322 (59.0)	.630 (16.0)	2.276 (57.8)

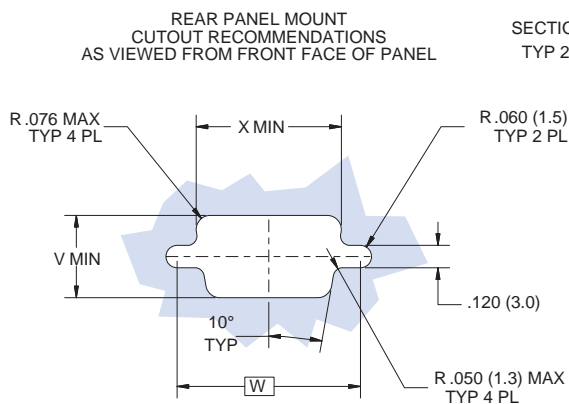
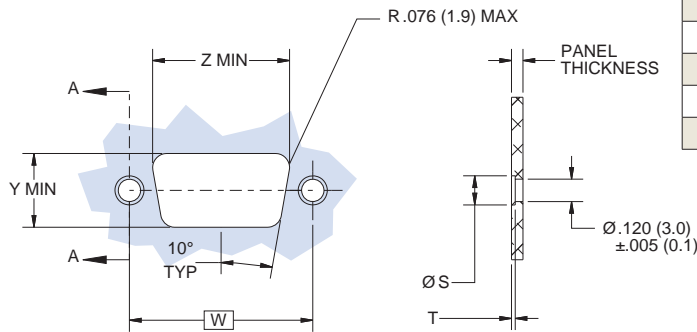

Table IV: Panel Thickness

Panel Code	Panel Thickness	S	T
R1	.031 (0.79)	N/A	N/A
R2	.047 (1.19)	.156/.199 (4.0/5.1)	.005 (0.13)
R3	.062 (1.57)	.156/.199 (4.0/5.1)	.020 (0.50)
R4	.093 (2.36)	.156/.199 (4.0/5.1)	.051 (1.30)
R5	.104 (2.64)	.156/.199 (4.0/5.1)	.061 (1.55)
R6	.125 (3.18)	.156/.199 (4.0/5.1)	.082 (2.08)
R7	.156 (3.96)	.156/.199 (4.0/5.1)	.114 (2.90)

Dimensions in inches (millimeters) and are subject to change without notice.



240-021

D-Subminiature Filter Connector

Solder Cup / Straight PCB Contacts • Connector Footprints

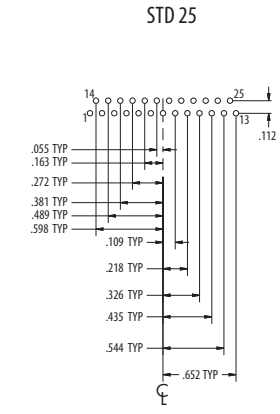
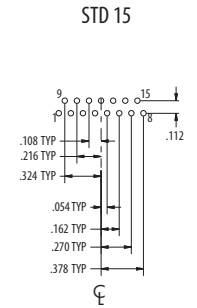
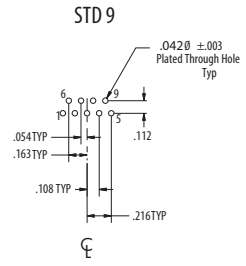

E

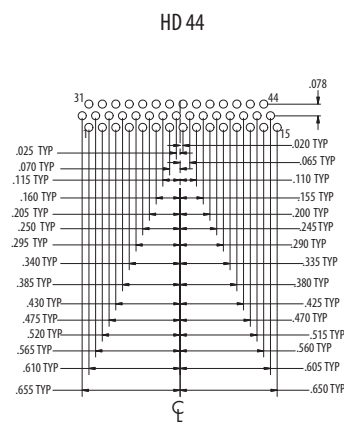
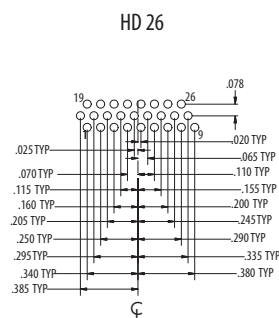
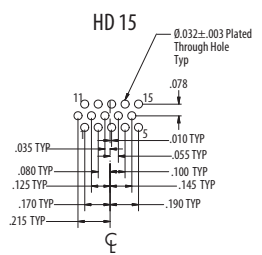
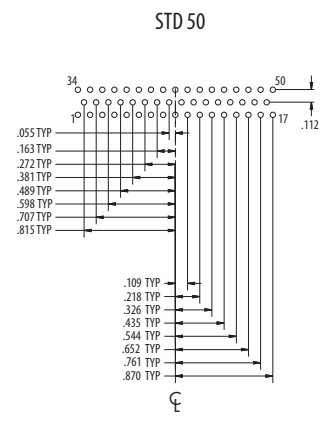
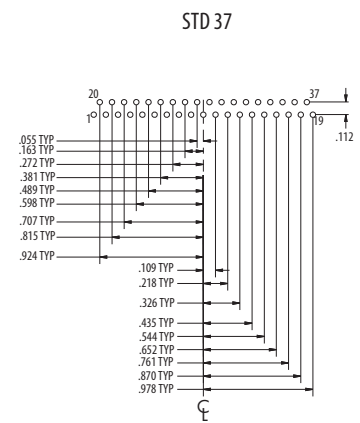

PCB patterns for high density inserts as viewed from non component side of PCB. Patterns shown are for pin inserts, sockets are mirrored around center line.

Dimensions in inches (millimeters) and are subject to change without notice.

240-021
D-Subminiature Filter Connector
 Solder Cup / Straight PCB Contacts • Connector Footprints



D-Subminiature
 MIL-DTL-24308 Type

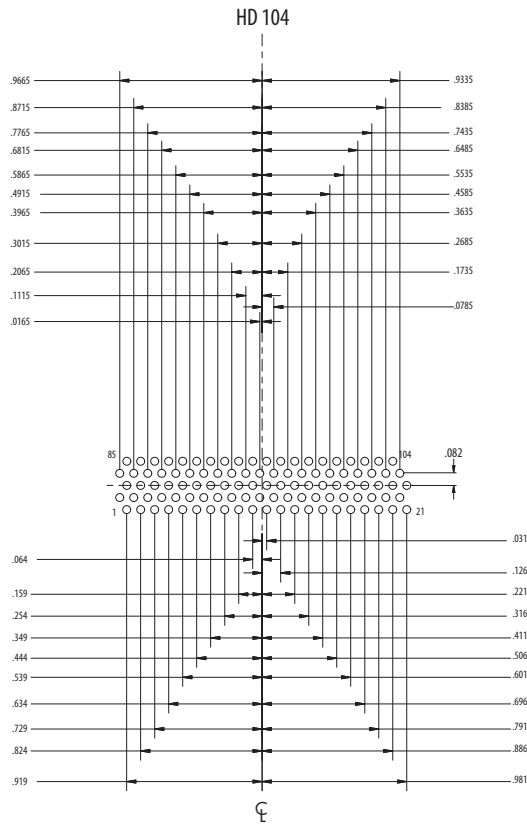
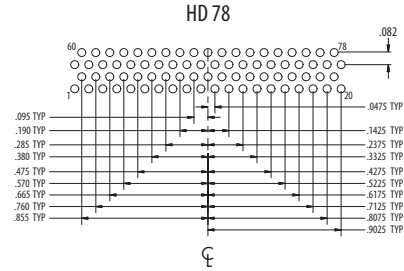
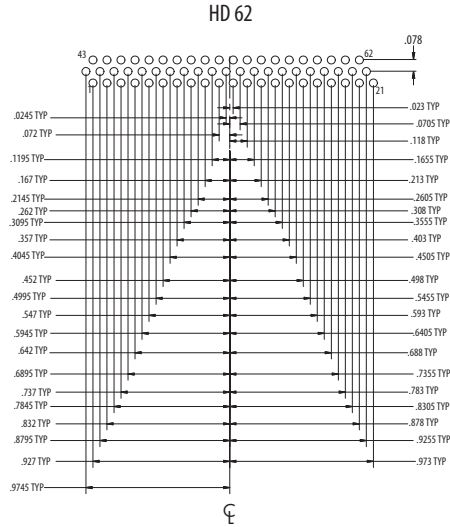

Dimensions in inches (millimeters) and are subject to change without notice.

E

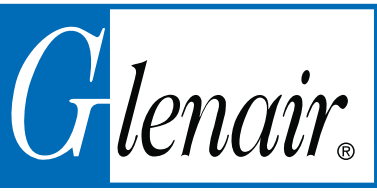

240-066 D-Subminiature Filter Connector Right Angle PCB Contacts

How To Order Filter D-Subminiature Right-Angle Mount Connectors										
Sample Part Number	240-066	S	-15	P	Z2	C	A	C	M	-G
Series	240-066									
Contact Density	S - Standard H - High									
Number of Contacts	9, 15, 25, 26, 37, 44, 50, 62, 78, 104 (See Table II)									
Contact Type	P - Pin S - Socket (See Table I)									
Shell Material/Finish	Aluminum Shell			Brass Shell						
	ME - Electroless Nickel JF - Yellow Cadmium			GS - Gold						
	MT - Nickel-PTFE Z2 - Gold E - Chem Film									
Filter Type	C - C Filter P - Pi Filter (See Table I)									
Filter Class	A, B, C, D, E, F, G, J (See Table I)									
Mounting Options	B - No Hardware C - 4-40 Clinch Nut M - Metric Thread (M3)									
Footprint Type	M - Mil-Spec E - European (See Table V)									
EMI Spring	G - EMI Spring (Plug/Pin Only) N - No Spring									

E

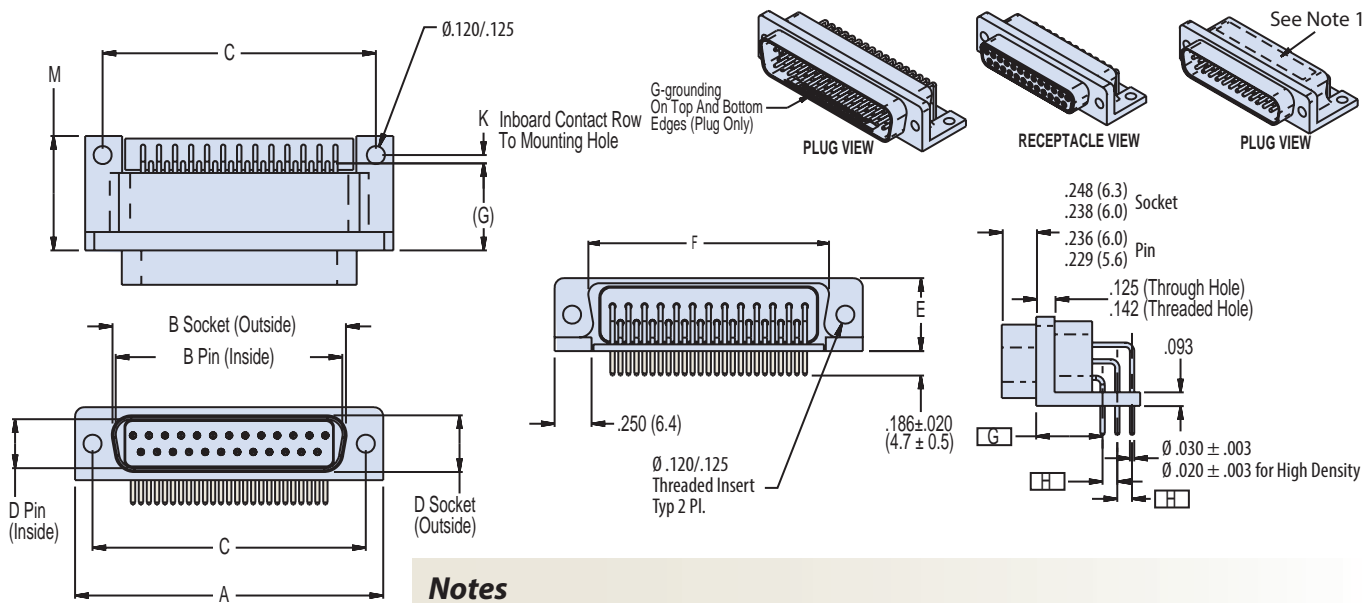

Class	Pi - Circuit (pF)	C - Circuit (pF)
A	38,000 - 56,000	19,000 - 28,000
B	32,000 - 45,000	16,000 - 22,500
C	18,000 - 33,000	9,000 - 16,500
D	8,000 - 12,000	4,000 - 6,000
E	3,300 - 5,000	1,650 - 2,500
F	800 - 1,300	400 - 650
G	400 - 600	200 - 300
J	70 - 120	35 - 60

Notes

1. Assembly to be identified with Glenair's name, part number, and date code space permitting
2. Dimensions B and D taken from inside of shell for Pin/Plug and outside for Socket/Receptacle.
3. Electrical Performance:
 Dielectric Withstanding Voltage: 500 VDC
 Insulation Resistance: 5,000 megohms @ 200 VDC
 Current Rating Standard Density: 7.5 Amps max.
 Current Rating High Density: 5 Amps max.

Materials/Finishes:

Insulators - High Grade Rigid Dielectric/N.A
 Contacts - Copper Alloy/Gold Plated

Dimensions in inches (millimeters) and are subject to change without notice.

240-066
D-Subminiature Filter Connector
Right Angle PCB Contacts



D-Subminiature
MIL-DTL-24308 Type

Table II: Dimensions

Shell Size	Number of Contacts		A	B	C	D	E	F
	STD	HD	±.015 (0.38)	±.005 (0.13)	±.005 (0.13)	±.005 (0.13)	±.015 (0.38)	Max
1	9P	15P	1.213 (30.8)	.666 (16.9)	.984 (25.0)	.329 (8.4)	.494 (12.5)	.769 (19.5)
	9S	15S	1.213 (30.8)	.643 (16.3)	.984 (25.0)	.311 (7.9)	.494 (12.5)	.769 (19.5)
2	15P	26P	1.541 (39.1)	.994 (25.2)	1.312 (33.3)	.329 (8.4)	.494 (12.5)	1.093 (27.8)
	15S	26S	1.541 (39.1)	.971 (24.7)	1.312 (33.3)	.311 (7.9)	.494 (12.5)	1.093 (27.8)
3	25P	44P	2.088 (53.0)	1.534 (39.0)	1.852 (47.0)	.329 (8.4)	.494 (12.5)	1.635 (41.5)
	25S	44S	2.088 (53.0)	1.511 (38.4)	1.852 (47.0)	.311 (7.9)	.494 (12.5)	1.635 (41.5)
4	37P	62P	2.729 (69.3)	2.182 (55.4)	2.500 (63.5)	.329 (8.4)	.494 (12.5)	2.282 (58.0)
	37S	62S	2.729 (69.3)	2.159 (54.8)	2.500 (63.5)	.311 (7.9)	.494 (12.5)	2.282 (58.0)
5	50P	78P	2.635 (66.9)	2.079 (52.8)	2.406 (61.1)	.441 (11.2)	.605 (15.4)	2.188 (55.6)
	50S	78S	2.635 (66.9)	2.064 (52.4)	2.406 (61.1)	.423 (10.7)	.605 (15.4)	2.188 (55.6)
6	X	104P	2.729 (69.3)	2.212 (56.2)	2.500 (63.5)	.503 (12.8)	.668 (17.0)	2.312 (58.7)
		104S	2.729 (69.3)	2.189 (55.6)	2.500 (63.5)	.486 (12.3)	.668 (17.0)	2.312 (58.7)

Table V: Dimensions

Contact Density	# of Contacts	Footprint Type	H Basic	K Basic	M ± .015	
					Pi Filter	C Filter
Standard Density	9-37	Mil-Aero	.112 (2.8)	.056 (1.4)	.777 (19.7)	.637 (16.2)
		Euro Style	.100 (2.5)	.050 (1.3)	.765 (19.4)	.625 (15.9)
	50	Mil-Aero	.112 (2.8)	.112 (2.8)	.889 (22.6)	.749 (19.0)
		Euro Style	.100 (2.5)	.100 (2.5)	.865 (22.0)	.725 (18.4)
High Density	15-62	Mil-Aero	.078 (2.0)	.078 (2.0)	.821 (20.9)	.681 (17.3)
		Euro Style	.100 (2.5)	.100 (2.5)	.865 (22.0)	.725 (18.4)
	78	Mil-Aero	.082 (2.1)	.123 (3.12)	.911 (23.1)	.771 (19.6)
		Euro Style	.100 (2.5)	.150 (3.81)	.965 (24.5)	.825 (21.0)
	104	Mil-Aero	.082 (2.1)	.200 (5.08)	1.065 (27.1)	.853 (21.7)
		Euro Style	.100 (2.5)	.164 (4.2)	.993 (25.2)	.925 (23.5)

Table III: Cut-Out Dimensions

Shell Size	N BSC	P Min	R Min
1	.984 (25.0)	.396 (10.1)	.735 (18.7)
2	1.312 (33.3)	.396 (10.1)	1.060 (26.9)
3	1.852 (47.0)	.396 (10.1)	1.603 (40.7)
4	2.500 (63.5)	.396 (10.1)	2.251 (57.2)
5	2.406 (61.1)	.510 (13.0)	2.148 (55.0)
6	2.500 (63.5)	.630 (16.0)	2.276 (57.8)

Table IV: Panel Thickness

Panel Code	Panel Thickness	S	T
R1	.031 (0.79)	N/A	N/A
R2	.047 (1.19)	.156/.199 (4.0/5.1)	.005 (0.13)
R3	.062 (1.57)	.156/.199 (4.0/5.1)	.020 (0.50)
R4	.093 (2.36)	.156/.199 (4.0/5.1)	.051 (1.30)
R5	.104 (2.64)	.156/.199 (4.0/5.1)	.061 (1.55)
R6	.125 (3.18)	.156/.199 (4.0/5.1)	.082 (2.08)
R7	.156 (3.96)	.156/.199 (4.0/5.1)	.114 (2.90)

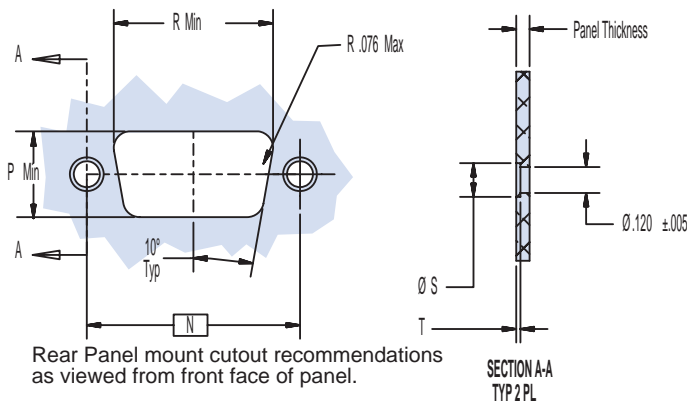

Dimensions in inches (millimeters) and are subject to change without notice.

E

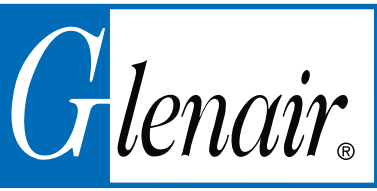

240-066
D-Subminiature Filter Connector
Right Angle PCB Contacts • Connector Footprints

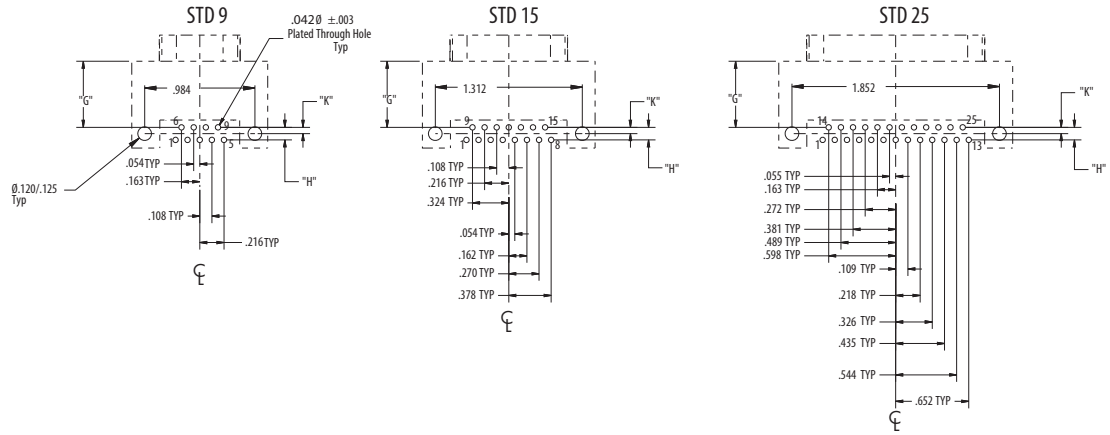

E

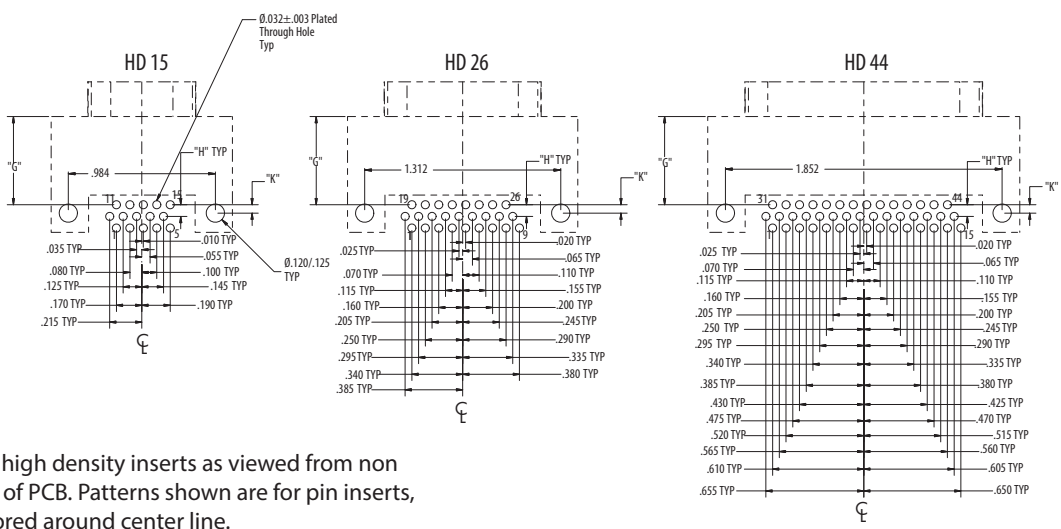
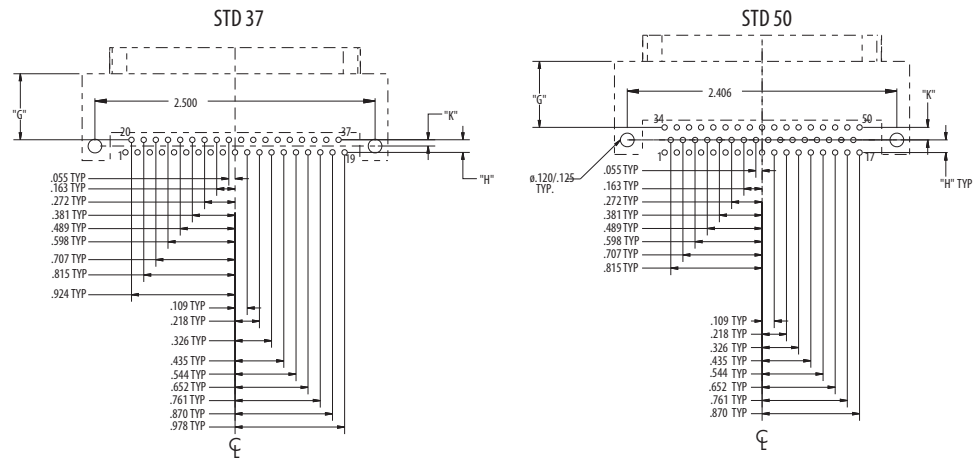

PCB patterns for high density inserts as viewed from non component side of PCB. Patterns shown are for pin inserts, sockets are mirrored around center line.

Dimensions in inches (millimeters) and are subject to change without notice.

© 2013 Glenair, Inc. U.S. CAGE Code 06324 Printed in U.S.A.

240-066
D-Subminiature Filter Connector
 Right Angle PCB Contacts • Connector Footprints



D-Subminiature
 MIL-DTL-24308 Type

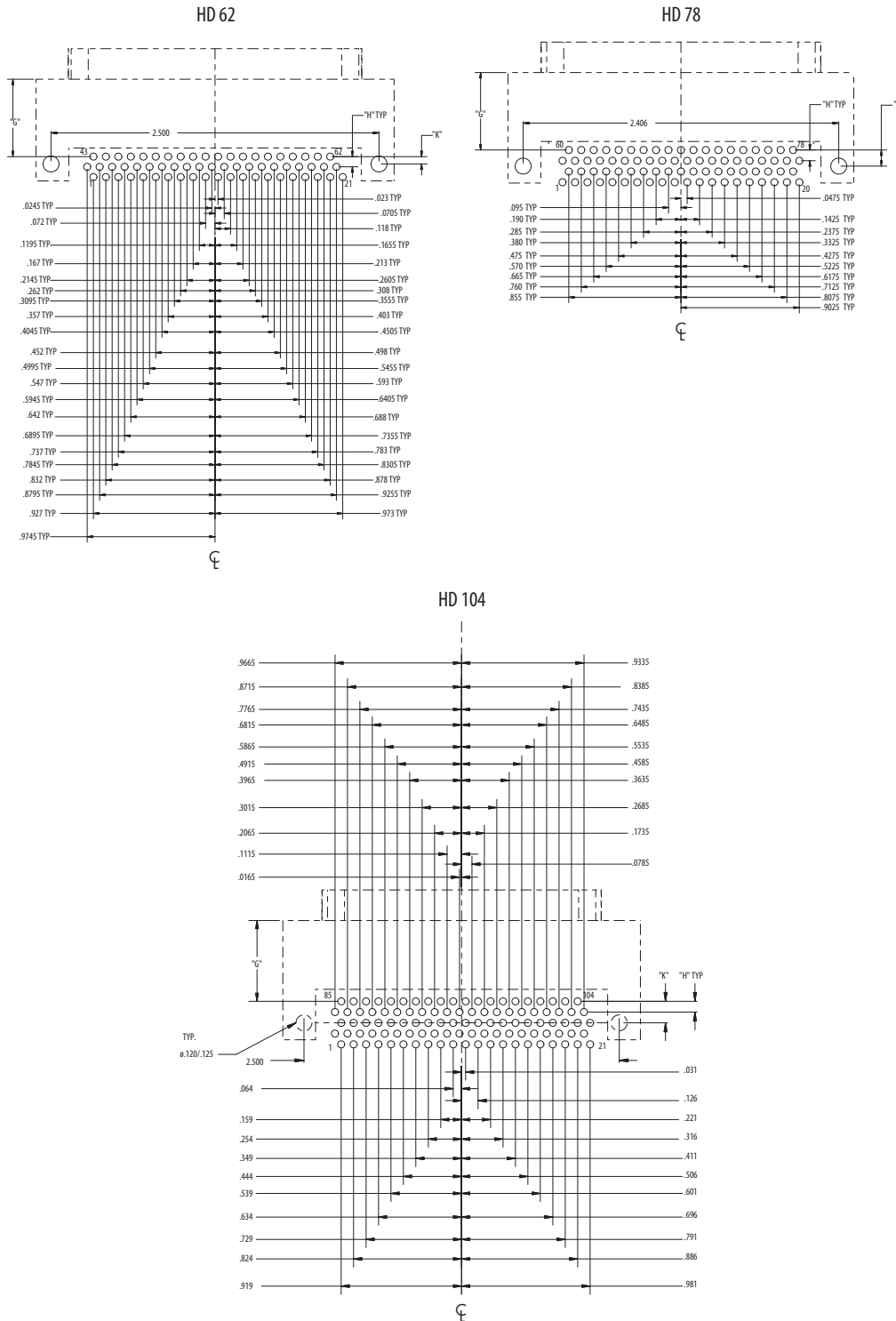

Dimensions in inches (millimeters) and are subject to change without notice.

© 2013 Glenair, Inc.

U.S. CAGE Code 06324

Printed in U.S.A.

E



240-051 D-Subminiature Filter Adapter

How To Order Filter D-Subminiature Sav-Con® Connector Savers							
Sample Part Number	240-051	-5H78	GS	P	G	G	B
Series	240-051						
Shell Size/ Insert Arrangement	See Table I						
Shell Material/Finish	Aluminum Shell			Brass Shell			
	ME - Electroless Nickel	JF - Yellow Cadmium		GS - Gold			
	MT - Nickel-PTFE	Z2 - Gold	E - Chem Film				
Filter Type	C - C Filter P - Pi Filter (See Table I)						
Filter Class	A, B, C, D, E, F, G, J (See Table I)						
EMI Spring	G - EMI Spring (Plug/Pin Only) N - No Spring						
Hardware Option	B - No Hardware P - Combination Jackpost/Jackscrew P1 - Fixed Jackposts, both sides						

E

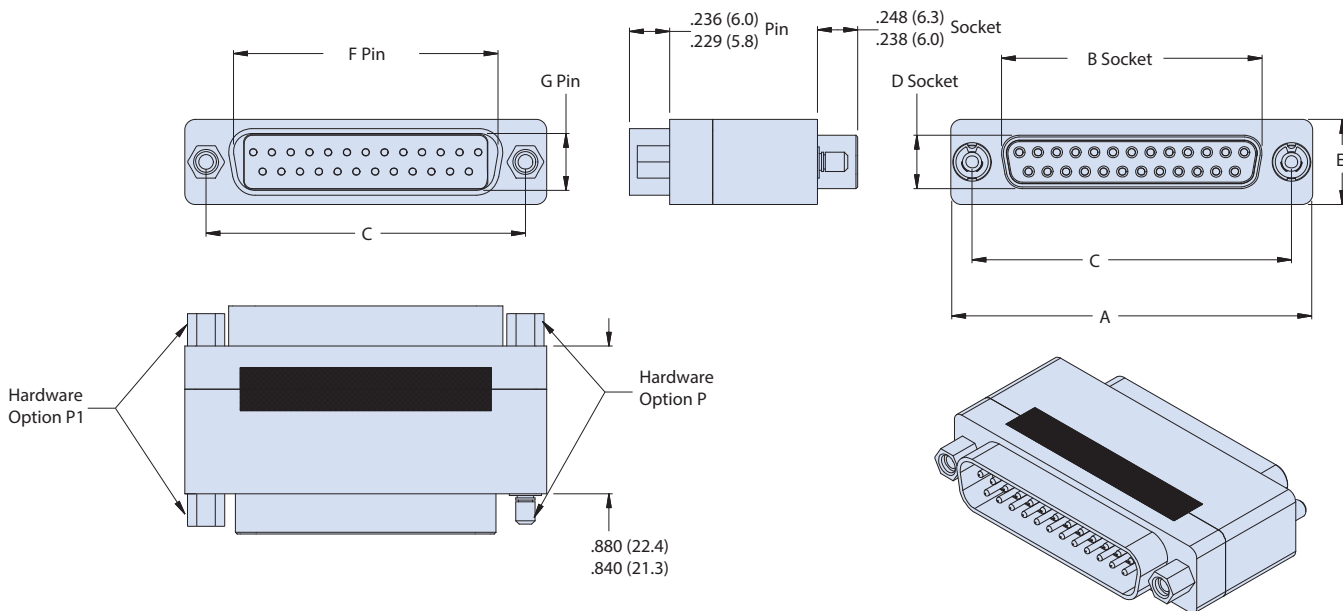

Class	Pi - Circuit (pF)	C - Circuit (pF)
A	38,000 - 56,000	19,000 - 28,000
B	32,000 - 45,000	16,000 - 22,500
C	18,000 - 33,000	9,000 - 16,500
D	8,000 - 12,000	4,000 - 6,000
E	3,300 - 5,000	1,650 - 2,500
F	800 - 1,300	400 - 650
G	400 - 600	200 - 300
J	70 - 120	35 - 60

Notes

1. Assembly to be identified with Glenair's name, part number, and date code space permitting
2. Dimensions B and D taken from inside of shell for Pin/Plug and outside for Socket/Receptacle.
3. Electrical Performance:
Dielectric Withstanding Voltage: 500 VDC
Insulation Resistance: 5,000 megohms @ 200 VDC
Current Rating Standard Density: 7.5 Amps max.
Current Rating High Density: 5 Amps max.

Materials/Finishes:

Insulators - High Grade Rigid Dielectric/N.A.
Contacts - Copper Alloy/Gold Plated

Dimensions in inches (millimeters) and are subject to change without notice.

240-051
D-Subminiature Filter Adapter



D-Subminiature
MIL-DTL-24308 Type

Table II: Dimensions

Shell Size Insert Arrangement	Contact Size	Contact Qty	A ±.015	B ±.005	C ±.005	D ±.005	E ±.015	F ±.005	G ±.005
1S9	#20	9	1.243	0.643	0.984	0.311	0.494	0.666	0.329
1H15	#22	15	(31.6)	(16.3)	(25.0)	(7.9)	(12.5)	(16.9)	(8.4)
2S15	#20	15	1.571	0.971	1.312	0.311	0.494	0.994	0.329
2H26	#22	26	(39.9)	(24.7)	(33.3)	(7.9)	(12.5)	(25.2)	(8.4)
3S25	#20	25	2.118	1.511	1.852	0.311	0.494	1.534	0.329
3H44	#22	44	(53.8)	(38.4)	(47.0)	(7.9)	(12.5)	(39.0)	(8.4)
4S37	#20	37	2.759	2.159	2.500	0.311	0.494	2.182	0.329
4H62	#22	62	(70.1)	(54.8)	(63.5)	(7.9)	(12.5)	(55.4)	(8.4)
5S50	#20	50	2.665	2.064	2.406	0.423	0.605	2.079	0.441
5H78	#22	78	(67.7)	(52.4)	(61.1)	(10.7)	(15.4)	(52.8)	(11.2)
6H104	#22	104	2.759	2.189	2.500	0.486	0.668	2.212	0.503
			(70.1)	(55.6)	(63.5)	(12.3)	(17.0)	(56.2)	(12.8)

E

Dimensions in inches (millimeters) and are subject to change without notice.

© 2013 Glenair, Inc.

U.S. CAGE Code 06324

Printed in U.S.A.



240-083 HiPer-D® Filter Connector with Crimp Removable Contacts

How To Order Filter D-Subminiature Sav-Con® Connector Connectors							
Sample Part Number	240-083	-5H78	P	M	P	G	B
Series	240-083						
Shell Size/ Insert Arrangement	See Table II						
Contact Type	P - Pin/Plug S - Socket/Receptacle						
Shell Material/Finish	Aluminum Shell ME - Electroless Nickel JF - Yellow Cadmium MT - Nickel-PTFE Z2 - Gold E - Chem Film			Brass Shell GS - Gold			
Filter Type	C - C Filter P - Pi Filter (See Table I)						
Filter Class	A, B, C, D, E, F, G, J (See Table I)						
EMI Spring	G - EMI Spring (Plug/Pin Only) N - No Spring						
Hardware Option	B - No Hardware C - 4-40 Clinch Nut						

E

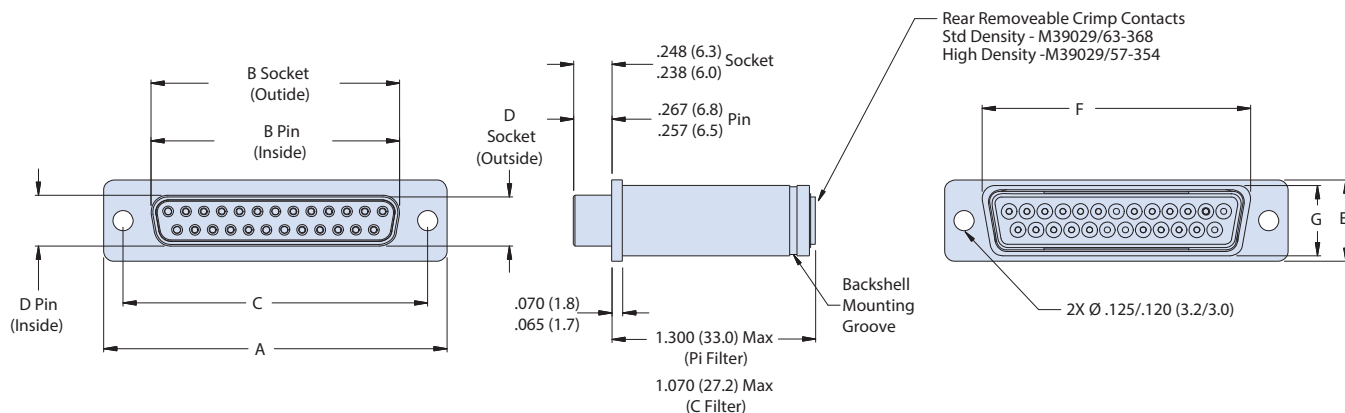

Notes

- Assembly to be identified with Glenair's name, part number, and date code space permitting
- Dimensions B and D taken from inside of shell for Pin/Plug and outside for Socket/Receptacle.
- Electrical Performance:
Dielectric Withstanding Voltage: 500 VDC
Insulation Resistance: 5,000 megohms @ 200 VDC
Current Rating Standard Density: 7.5 Amps max.
Current Rating High Density: 5 Amps max.
- For front panel mount, use M24308/26 or 289-015 standoffs.
- For rear panel mount, use Glenair 289-015
- Connector is compatible with two-piece HiPer-D backshells.

Materials/Finishes:

Insulators - High Grade Rigid Dielectric / NA
Contacts - Copper Alloy / Gold Plated
Wire sealing grommet and pin interfacial seal - Fluorosilicone / NA

Class	Pi - Circuit (pF)	C - Circuit (pF)
A	38,000 - 56,000	19,000 - 28,000
B	32,000 - 45,000	16,000 - 22,500
C	18,000 - 33,000	9,000 - 16,500
D	8,000 - 12,000	4,000 - 6,000
E	3,300 - 5,000	1,650 - 2,500
F	800 - 1,300	400 - 650
G	400 - 600	200 - 300
J	70 - 120	35 - 60

Dimensions in inches (millimeters) and are subject to change without notice.

240-083 HiPer-D® Filter Connector with Crimp Removable Contacts



D-Subminiature
MIL-DTL-24308 Type

Table II - Shell Size, Insert Arrangement, Contacts and Dimensions

Shell Size - Insert Arrangement	Contact Size	Contact Qty	Shell Size	Contact Type	A ±.015	B ±.005	C ±.005	D ±.005	E ±.015	F Max	G Max
1S9	#20	9	1	pin	1.213 (30.8)	0.666 (16.9)	0.984 (25.0)	0.329 (8.4)	0.494 (12.5)	0.769 (19.5)	0.432 (11.0)
1H15	#22	15		socket	1.213 (30.8)	0.643 (16.3)	0.984 (25.0)	0.311 (7.9)	0.494 (12.5)	0.769 (19.5)	0.432 (11.0)
2S15	#20	15	2	pin	1.541 (39.1)	0.994 (25.2)	1.312 (33.3)	0.329 (8.4)	0.494 (12.5)	1.093 (27.8)	0.432 (11.0)
2H26	#22	26		socket	1.541 (39.1)	0.971 (24.7)	1.312 (33.3)	0.311 (7.9)	0.494 (12.5)	1.093 (27.8)	0.432 (11.0)
3S25	#20	25	3	pin	2.088 (53.0)	1.534 (39.0)	1.852 (47.0)	0.329 (8.4)	0.494 (12.5)	1.635 (41.5)	0.432 (11.0)
3H44	#22	44		socket	2.088 (53.0)	1.511 (38.4)	1.852 (47.0)	0.311 (7.9)	0.494 (12.5)	1.635 (41.5)	0.432 (11.0)
4S37	#20	37	4	pin	2.729 (69.3)	2.182 (55.4)	2.500 (63.5)	0.329 (8.4)	0.494 (12.5)	2.282 (58.0)	0.432 (11.0)
4H62	#22	62		socket	2.729 (69.3)	2.159 (54.8)	2.500 (63.5)	0.311 (7.9)	0.494 (12.5)	2.282 (58.0)	0.432 (11.0)
5S50	#20	50	5	pin	2.635 (66.9)	2.079 (52.8)	2.406 (61.1)	0.441 (11.2)	0.605 (15.4)	2.188 (55.6)	0.544 (13.8)
5H78	#22	78		socket	2.635 (66.9)	2.064 (52.4)	2.406 (61.1)	0.423 (10.7)	0.605 (15.4)	2.188 (55.6)	0.544 (13.8)
6H104	#22	104	6	pin	2.729 (69.3)	2.212 (56.2)	2.500 (63.5)	0.503 (12.8)	0.668 (17.0)	2.312 (58.7)	0.606 (15.4)
				socket	2.729 (69.3)	2.189 (55.6)	2.500 (63.5)	0.486 (12.3)	0.668 (17.0)	2.312 (58.7)	0.606 (15.4)

Table VI - Dimensions

Shell Size	A +.005 -.000	B	C +.005 -.000	D +.005 -.000	E +.005 -.000
1	.450	.984	.787	.409	.746
2	.450	1.312	1.111	.409	1.074
3	.450	1.852	1.653	.409	1.614
4	.450	2.500	2.300	.409	2.262
5	.552	2.406	2.190	.521	2.159
6	.614	2.500	2.315	.583	2.288

Table VII - Panel Dimensions

Panel Code	Panel Thickness	F ± .005	G
R1	.031	N/A	N/A
R2	.047	N/A	N/A
R3	.062	N/A	N/A
R4	.093	.230	N/A
R5	.104	.230	.031
R6	.125	.230	.063
R7	.156	.230	.094

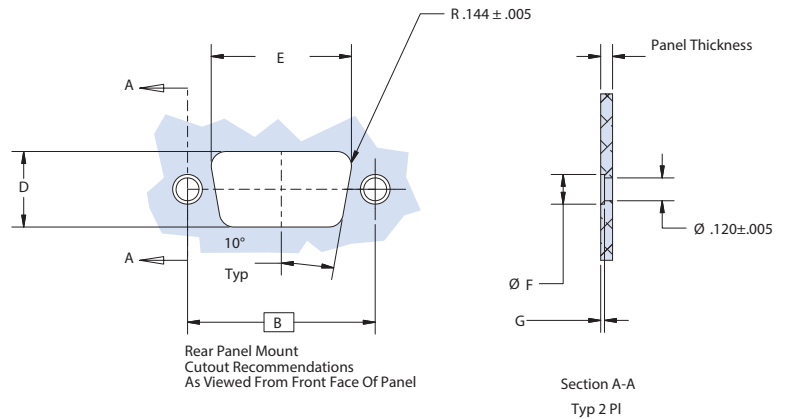
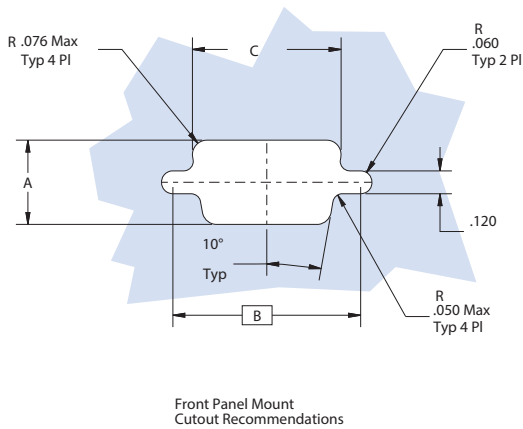

Dimensions in inches (millimeters) and are subject to change without notice.

E

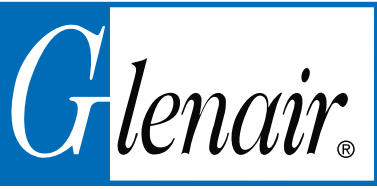

2470-1112 Combo-D Filtered Plug Connector

E

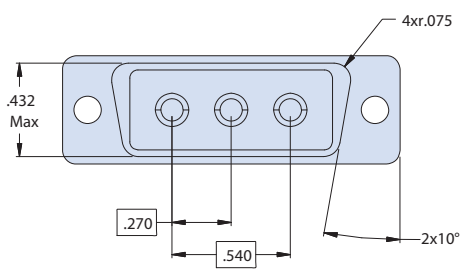
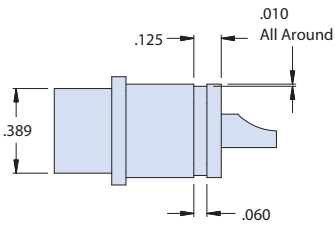
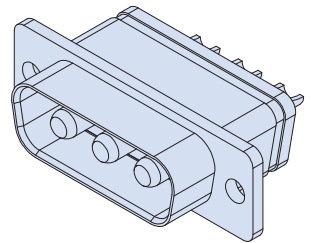
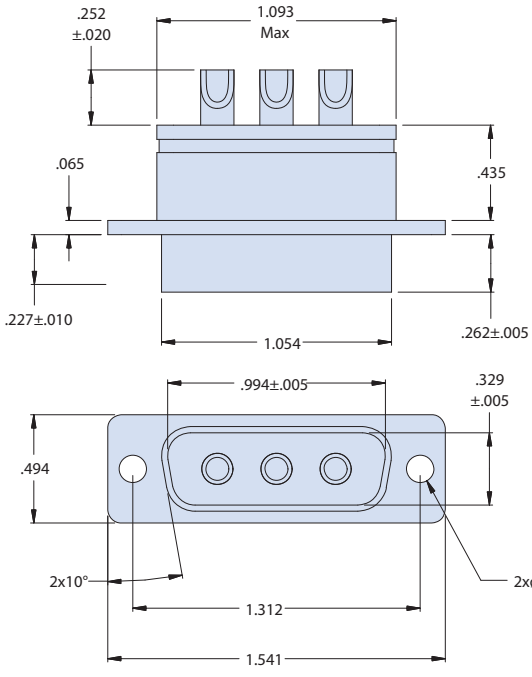

Notes

1. Assembly to be identified with Glenair's name, part number, and date code space permitting
2. Electrical Performance: C filter
Capacitance: 80 – 120 nF
Dielectric Withstanding Voltage: 500 VDC
Insulation Resistance: 5,000 Megohms @ 200 VDC

Materials/Finishes:

Shell - Aluminum/Yellow Chromate over Cadmium (JF)
Insulators - High Grade Rigid Dielectric / NA
Contacts - Copper Alloy / Gold Plated
Hardware - Stainless Steel/Passivated
Interfacial Seal - Fluorosilicone Blend / NA

Dimensions in inches (millimeters) and are subject to change without notice.

249-EMITS-DSUB EMITS EMI Troubleshooter D-Sub Edition



D-Subminiature
MIL-DTL-24308 Type

How To Order EMITS		
Sample Part Number	249-EMITS-DSUB	-ME
Series	249-EMITS-DSUB	
Plating	ME - Aluminum / Electroless Nickel	
	Z2 - Aluminum / Gold	
	GS - Brass / Gold	

Item	Part Number	Qty.
1	740 X CASE	1
2	U1733C LCR METER	1
3	249-051	1
4	7278438 TOOL	1
5	240-051-1S9XPAGB	1
6	240-051-1S9XCAGB	1
7	240-051-1S9XCDGB	1
8	240-051-2S15XPAGB	1
9	240-051-2S15XCAGB	1
10	240-051-2S15XCDGB	1
11	240-051-3S25XPAGB	1
12	240-051-3S25XCAGB	1
13	240-051-3S25XCDGB	1
14	240-051-4S37XPAGB	1
15	240-051-4S37XCAGB	1
16	240-051-4S37XCDGB	1
17	240-051-5S50XPAGB	1
18	240-051-5S50XCAGB	1
19	240-051-5S50XCDGB	1
20	240-051-1H15XPAGB	1
21	240-051-1H15XCAGB	1
22	240-051-1H15XCDGB	1
23	240-051-2H26XPAGB	1
24	240-051-2H26XCAGB	1
25	240-051-2H26XCDGB	1
26	240-051-3H44XPAGB	1
27	240-051-3H44XCAGB	1
28	240-051-3H44XCDGB	1
29	240-051-4H62XPAGB	1
30	240-051-4H62XCAGB	1
31	240-051-4H62XCDGB	1
32	240-051-5H78XPAGB	1
33	240-051-5H78XCAGB	1
34	240-051-5H78XCDGB	1
35	240-051-6H104XPAGB	1
36	240-051-6H104XCAGB	1
37	240-051-6H104XCDGB	1
38	5274562 VIAL	2

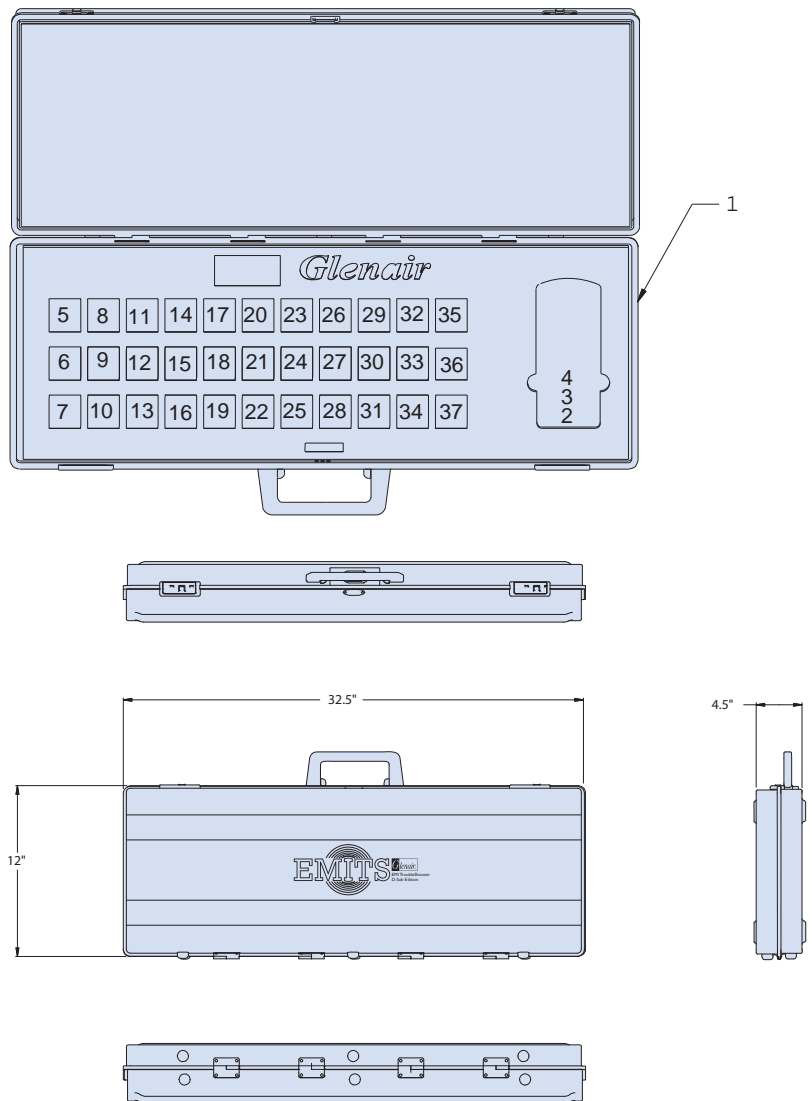

E

Dimensions in inches (millimeters) and are subject to change without notice.

© 2013 Glenair, Inc.

U.S. CAGE Code 06324

Printed in U.S.A.

SERIES 970
HIGH AMPACITY,
HARSH ENVIRONMENT

PowerTrip™

*The power connector
for extreme environments—Now
available EMI/EMP filter class*

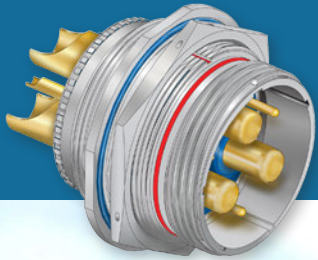

Protect circuits with Series 970 PowerTrip™ connectors

The Series 970 PowerTrip connector fills the need for a military-grade harsh environment power connector with improved mechanical, environmental and electrical performance. PowerTrip™ also delivers reduced size and weight compared to lower-density 5015 type power connectors. Featuring triple-start mating threads, crimp rear-release contacts, upgraded finish choices and improved EMI protection, the PowerTrip™ connector is ideal for power distribution units, hybrid electric drives, motors, and other high current, high-reliability applications. Available EMI/EMP filter receptacles are rated to 1,250VDC DWV and supplied with solder cups for easy termination and installation.



Glenair®

Glenair, Inc.
1211 Air Way
Glendale, CA
91201-2497
818-247-6000
sales@glenair.com
www.glenair.com

Product Selection Guide

240-970W
Page F-2

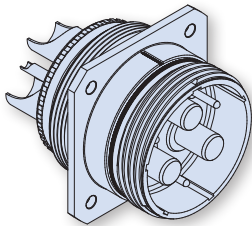

PowerTrip Filter Receptacle, Square Flange

240-970J
Page F-4

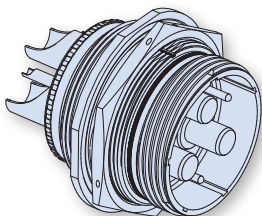

PowerTrip Filter Receptacle, Jam Nut

Dimensions in inches (millimeters) and are subject to change without notice.

240-970W FILTER RECEPTACLE, SQUARE FLANGE

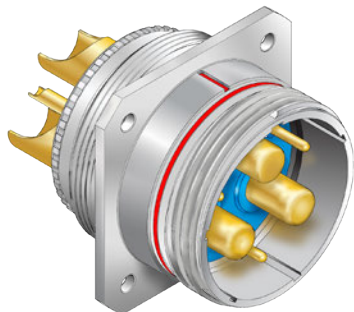

Series 970 PowerTrip™ filter receptacles feature planar array ceramic capacitors. Solder cup contacts are factory-installed, epoxy sealed and are non-removable. Socket contacts have copper alloy louverband spring for multiple points of electrical contact. Coupling threads are triple-start ACME type. Contacts are gold plated. Fluorosilicone rubber face seal on pin connector. Aluminum or stainless steel shell.

- Planar Array C Filter
- -55° C to +125° C
- 1,250 VDC DWV Rating
- Solder Cup Contacts

Insertion Loss			
Insertion Loss, dB minimum, 25°C			
Frequency	CX	CY	CZ
	80k-120k pF	40k-60k pF	30k-45k pF
1 MHz	22	16	13
10 MHz	41	36	33
100 MHz	56	53	52
500 -1000 MHz	60	57	57

HOW TO ORDER

SERIES	SHELL MATL AND FINISH	SHELL SIZE - INSERT ARRANGEMENT					CONTACT TYPE	FILTER TYPE & CAPACITANCE	MOUNTING HOLE	KEY POS.
		Contact Arr.	Contact Size and Qty							
F 240-970W Filter Receptacle, Square Flange	ME Aluminum, Electroless Nickel Finish						PS Pin Contact, Solder Cup	CX C Filter 80,000-120,000 pF	N Thru-Hole	1 Position 1
		18-2			2					
				2			SS Socket Contact, Solder Cup	CY C Filter 40,000-60,000 pF	T Clinch Nuts Installed in Mounting Holes for Back Panel Mounting.	2 Position 2
	18-4		2	2						
	MT Aluminum, Nickel-PTFE Finish	20-3			3			CZ C Filter 30,000-45,500 pF		3 Position 3
		20-4			4					
		20-5		2	3					
		20-7	4		3					
	NF Aluminum, Olive Drab Cadmium	24-2				2				4 Position 4
		24-3				3				
		24-5			5					
	ZR Aluminum, Black Zinc- Nickel Finish	24-6		4		2				5 Position 5
		24-A6		3		3				
		28-4				4				
	ZMT Stainless Steel, Nickel-PTFE Finish	28-9	5			4				6 Position 6
		32-2					2			
		32-3					3			
		32-4				2	2			
	Z1 Stainless Steel, Passivated	32-5				5				
		32-6		3			3			
36-4						4				
						5				
Sample Part Number										
240-970W	ME		40-5				PS	CY	N	1

Dimensions in inches (millimeters) and are subject to change without notice.

Series 970 PowerTrip™ Connectors Filter Receptacles 240-970W Square Flange Receptacle



Series 970
PowerTrip™

240-970W FILTER RECEPTACLE, SQUARE FLANGE

Solder Cup Dimensions		
Contact Size	G Typ	
	In. ±.025	mm. ±0.64
16	.500	12.70
12	.500	12.70
8	.600	15.24
4	.800	20.32
1/0	.800	20.32

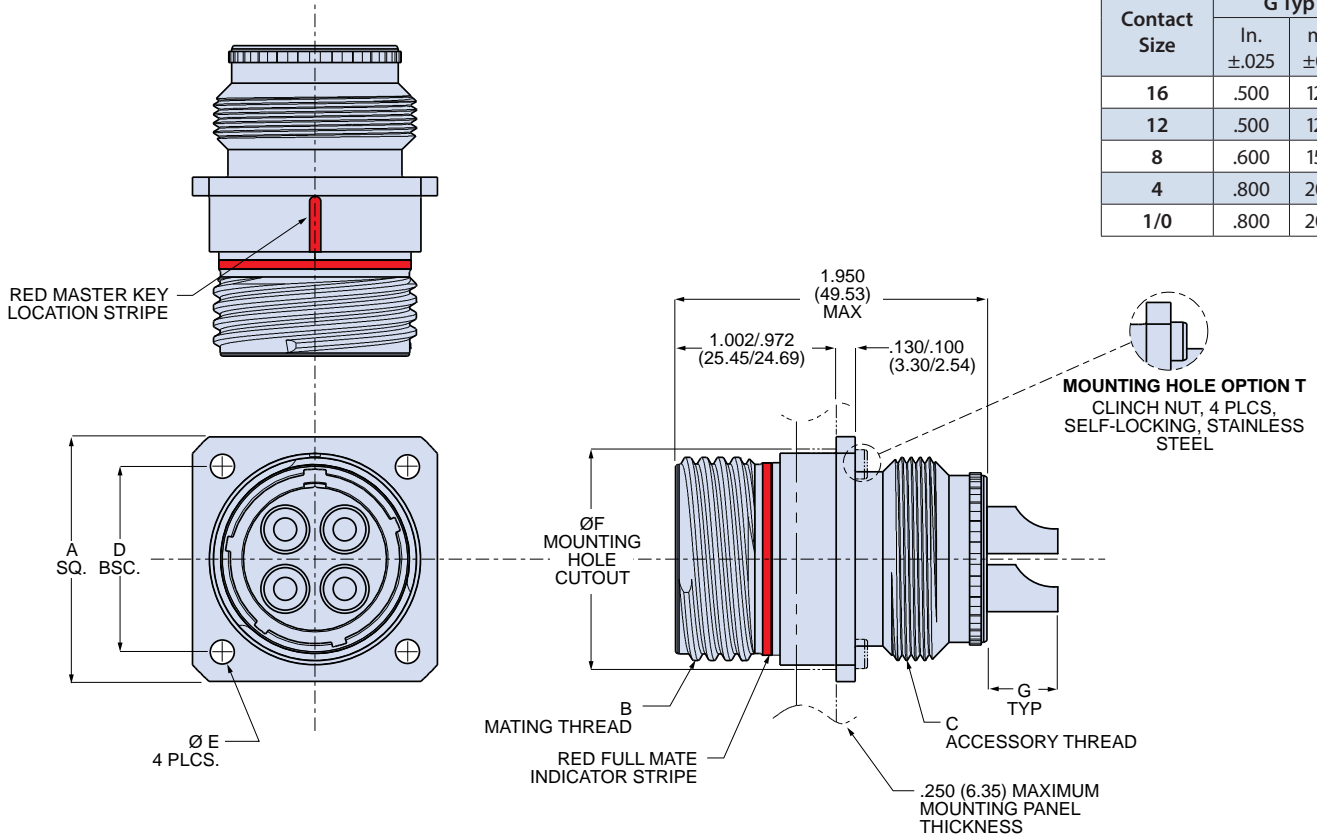

Dimensions											
Shell Size	A Sq.		B Mating Thread	C Accessory Thd	D Bsc		ø E		E Clinch Nut Thd	ø F	
	In.	mm.			In.	mm.	In.	mm.		In.	mm.
18	1.383	35.13	1.125-.1P-.3L-TS-2A	1.125-18 UNEF-2A	1.015	25.78	.146	3.71	6-32 UNC-2B	1.187	30.15
20	1.508	38.30	1.250-.1P-.3L-TS-2A	1.250-18 UNEF-2A	1.140	28.96	.146	3.71	6-32 UNC-2B	1.374	34.90
24	1.718	43.64	1.500-.1P-.3L-TS-2A	1.4375-18 UNEF-2A	1.281	32.54	.146	3.71	6-32 UNC-2B	1.562	39.67
28	2.138	54.31	1.750-.1P-.3L-TS-2A	1.8125-16 UN-2A	1.568	39.83	.170	4.32	8-32 UNC-2B	1.874	47.60
32	2.328	59.13	2.000-.1P-.3L-TS-2A	2.0625-16 UNS-2A	1.734	44.04	.170	4.32	8-32 UNC-2B	2.062	52.37
36	2.578	65.48	2.250-.1P-.3L-TS-2A	2.250-16 UN-2A	1.984	50.39	.170	4.32	8-32 UNC-2B	2.302	58.47
40	2.828	71.83	2.500-.1P-.3L-TS-2A	2.500-16 UN-2A	2.234	56.74	.170	4.32	8-32 UNC-2B	2.562	65.07

Materials and Finishes	
Shells, Jam Nuts	Aluminum alloy or stainless steel
Contacts	High conductivity copper alloy, gold over nickel plating
Insulators	Thermoset epoxy
Interfacial Seal	Fluorosilicone
Clinch Nut	Stainless steel

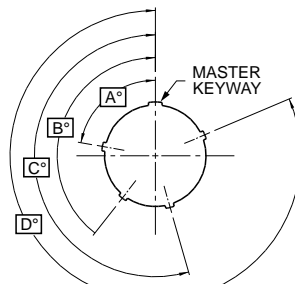

Key Positions				
Position	A°	B°	C°	D°
1	80	142	196	293
2	135	170	200	310
3	49	169	200	244
4	66	140	200	257
5	62	145	180	280
6	79	153	197	272

Dimensions in inches (millimeters) and are subject to change without notice.

© 2013 Glenair, Inc.

U.S. CAGE Code 06324

Printed in U.S.A.

240-970J FILTER RECEPTACLE, JAM NUT

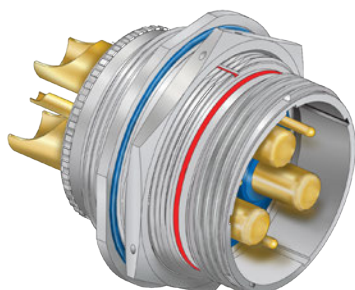

Series 970 PowerTrip™ filter receptacles feature planar array ceramic capacitors. Solder cup contacts are factory-installed, epoxy sealed and are non-removable. Socket contacts have copper alloy louverband spring for multiple points of electrical contact. Coupling threads are triple-start ACME type. Contacts are gold plated. Fluorosilicone rubber face seal on pin connector. Aluminum or stainless steel shell.

- Planar Array C Filter
- -55° C to +125° C
- 1,250 VDC DWV Rating
- Solder Cup Contacts

Insertion Loss			
Insertion Loss, dB minimum, 25°C			
Frequency	CX	CY	CZ
	80k-120k pF	40k-60k pF	30k-45k pF
1 MHz	22	16	13
10 MHz	41	36	33
100 MHz	56	53	52
500 -1000 MHz	60	57	57

HOW TO ORDER

SERIES	SHELL MATL AND FINISH	SHELL SIZE - INSERT ARRANGEMENT	CONTACT TYPE	FILTER TYPE & CAPACITANCE	MOUNTING STYLE	KEY POS.		
F 240-970J Filter Receptacle, Jam Nut	ME Aluminum, Electroless Nickel Finish	Contact Arr.	Contact Size and Qty	PS Pin Contact, Solder Cup	CX C Filter 80,000-120,000 pF	N Standard Mounting	1 Position 1	
		#16	#12					#8
	MT Aluminum, Nickel-PTFE Finish	18-2		2	SS Socket Contact, Solder Cup	CY C Filter 40,000-60,000 pF	3 Position 3	
		18-4	2	2				2 Position 2
		20-3		3				
		20-4		4				
		20-5	2	3				
		20-7	4	3				
	NF Aluminum, Olive Drab Cadmium	24-2		2	CZ C Filter 30,000-45,500 pF	5 Position 5		
		24-3		3			6 Position 6	
		24-5		5				
		24-6	4	2				
	ZR Aluminum, Black Zinc- Nickel Finish	24-A6	3	3				
		28-4		4				
		28-9	5	4				
		32-2			2			
	ZMT Stainless Steel, Nickel-PTFE Finish	32-3			3			
		32-4			2	2		
		32-5			5			
		32-6		3		3		
Z1 Stainless Steel, Passivated	36-4			4				
	40-5			5				
Sample Part Number								
240-970J	ME	40-5	PS	CY	N	1		

Dimensions in inches (millimeters) and are subject to change without notice.

Series 970 PowerTrip™ Connectors Filter Receptacles 240-970J Jam Nut Receptacle



Series 970
PowerTrip™

240-970J DIMENSIONS

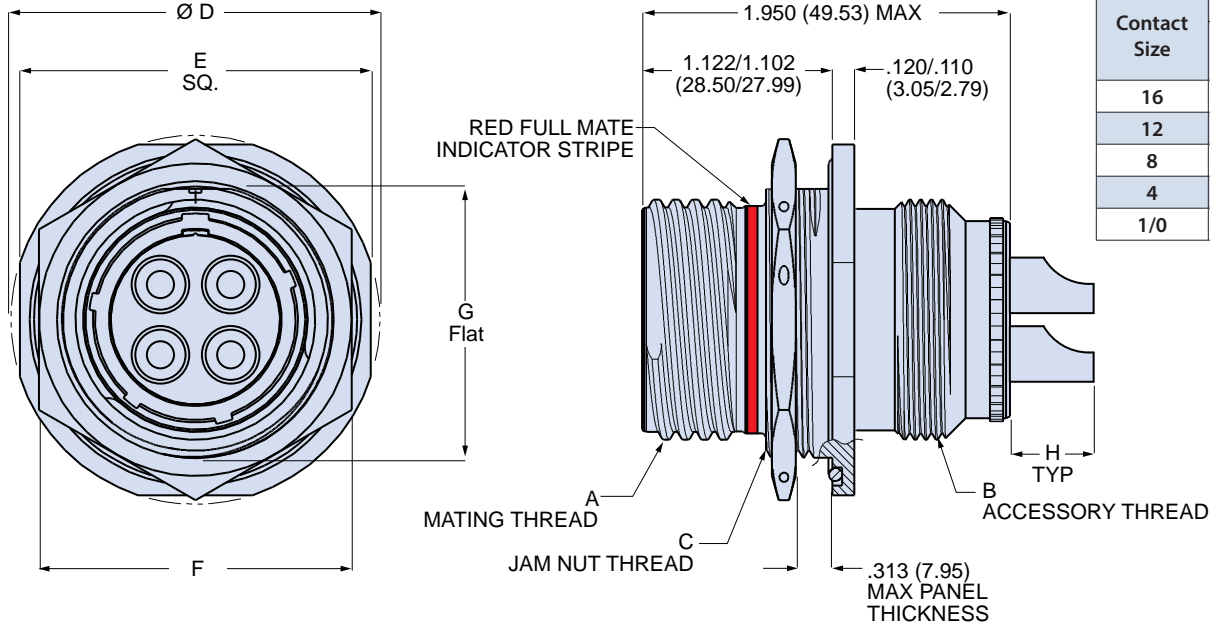

Contact Size	H Typ	
	In. ± 0.025	mm. ± 0.64
16	.500	12.70
12	.500	12.70
8	.600	15.24
4	.800	20.32
1/0	.800	20.32

Dimensions											
Shell Size	A Mating Thd.	B Accessory Thd.	C Jam Nut Thd.	$\varnothing D$		E Sq.		F		G Flat	
				In.	mm.	In.	mm.	In.	mm.	In.	mm.
18	1.125-1P-3L-TS-2A	1.125-18 UNEF-2A	1.250-18 UNEF-2A	1.733	44.02	1.639	41.63	1.438	36.53	1.212	30.78
20	1.250-1P-3L-TS-2A	1.250-18 UNEF-2A	1.4375-18 UNEF-2A	1.921	48.79	1.827	46.41	1.625	41.28	1.399	35.53
24	1.500-1P-3L-TS-2A	1.4375-18 UNEF-2A	1.625-18 UNEF-2A	2.108	53.54	2.014	51.16	2.000	50.80	1.587	40.31
28	1.750-1P-3L-TS-2A	1.8125-16 UN-2A	1.9375-16 UN-2A	2.425	61.60	2.327	59.11	2.188	55.58	1.899	48.23
32	2.000-1P-3L-TS-2A	2.0625-16 UNS-2A	2.125-16 UN-2A	2.607	66.22	2.514	63.86	2.375	60.33	2.084	52.93
36	2.250-1P-3L-TS-2A	2.250-16 UN-2A	2.375-16 UN-2A	2.857	72.57	2.763	70.18	2.625	66.68	2.323	59.00
40	2.500-1P-3L-TS-2A	2.500-16 UN-2A	2.625-16 UN-2A	3.107	78.92	3.013	76.53	2.875	73.03	2.548	64.72

Key Positions				
Position	A ⁰	B ⁰	C ⁰	D ⁰
1	80	142	196	293
2	135	170	200	310
3	49	169	200	244
4	66	140	200	257
5	62	145	180	280
6	79	153	197	272

Panel Cutout				
Shell Size	Diameter		Flat	
	In.	mm.	In.	mm.
		-.000 +.010	-.00 +0.25	-.000 +.010
18	1.254	31.85	1.217	30.91
20	1.441	36.60	1.404	35.66
24	1.629	41.38	1.592	40.64
28	1.941	49.30	1.904	48.36
32	2.129	54.08	2.092	53.14
36	2.379	60.43	2.328	59.13
40	2.629	66.78	2.553	64.85

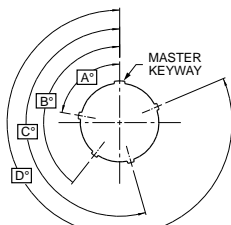
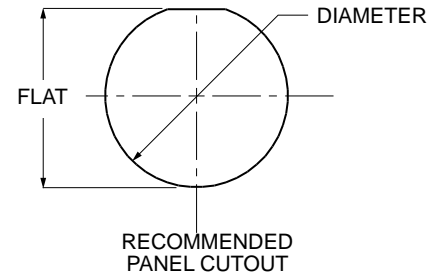

Dimensions in inches (millimeters) and are subject to change without notice.

ULTRAMINIATURE



Series 79 Filter Connectors

The ultraminiature rectangular with advanced environmental performance—now available in EMI/EMP filter class



The Glenair Series 79 Micro-Crimp is the rectangular version of our high-density and ultralightweight Series 80 Mighty Mouse circular. Like the Mighty Mouse, the Series 79 Micro-Crimp offers crimp, PCB, fiber optic, power, shielded, as well as pneumatic contact arrangements. Precision-machined aluminum shells are sealed to IP67. High density #23 contact arrangements are set on .076" centers and are available in over 30 tooled arrangements from 5 – 102 contacts. Integrated ground spring provides improved EMC performance. New EMI/EMP filter class connectors are available in 35 – 240,000 pF capacitance in both C and Pi architectures. All configurations are environmentally sealed for rugged applications including military aerospace.



Glenair, Inc.
1211 Air Way
Glendale, CA
91201-2497
818-247-6000
sales@glenair.com
www.glenair.com

Series 79 Filter Connectors Selection Guide



Product Selection Guide

240-790-028
Page G-2

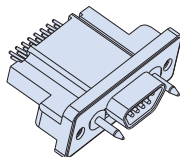

Filtered Receptacle, Rear Panel Mount with Straight PC Tails

240-790-029
Page G-8

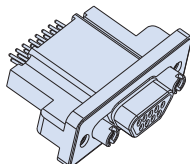

Filtered Plug, Rear Panel Mount with Straight PC Tails

240-790-043
Page G-14

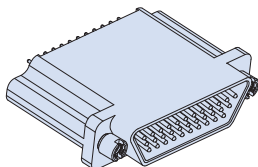

Filtered Receptacle, Vertical PCB Mount with Straight PC Tails

240-790-044
Page G-20

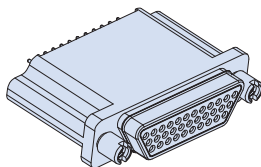

Filtered Plug, Vertical PCB Mount with Straight PC Tails

240-790-069
Page G-38

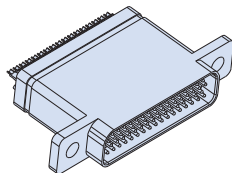

Filtered Standard Cable Receptacle with Solder Cup Termination

240-790-070
Page G-44

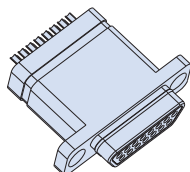

Filtered Standard Cable Plug with Solder Cup Termination

240-790-071
Page G-50

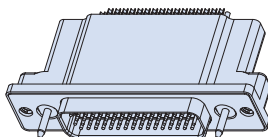

Filtered Receptacle, Rear Panel Mount with Solder Cup Termination

240-790-072
Page G-56

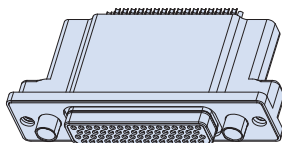

Filtered Plug, Rear Panel Mount with Solder Cup Termination

Dimensions in inches (millimeters) and are subject to change without notice.



240-790-028
Series 79 Filtered Receptacle
Rear Panel Mount with Straight PC Tails

How To Order Filter Series 79 Connectors

Sample Part Number	240-790-028	P	H-66	ME	P	D	P	A
Series	240-790-028							
Contact Type	P - Pin Contacts							
Insert Arrangement	(See Table I)							
Shell Material/Finish	Aluminum Shell ME - Electroless Nickel MT - Nickel-PTFE E - Chem Film Z2 - Gold UC - Zinc Cobalt with Black Chromate J - Cadmium with Yellow Chromate NF - Cad/O.D. over Electroless Nickel							
Filter Type	C - C Filter P - Pi Filter							
Filter Class	X, Y, Z, A, B, C, D, E, F, G, J (See Table II)							
Mating Hardware Options	P - Jackposts G - Male Guide Pins S - Female Guide Sockets N - No Mating Hardware (See Table III)							
PC Tail Length	A - .125" (3.18) B - .250" (6.35) C - .375" (9.53)							

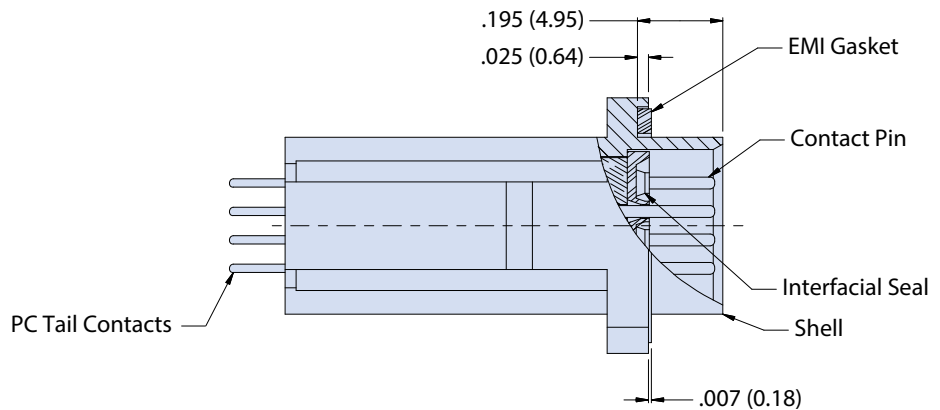
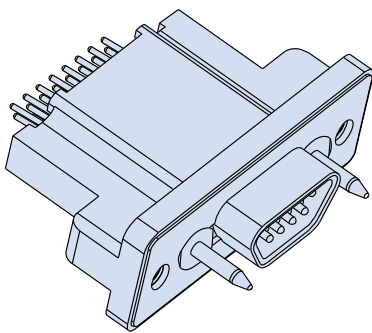

Notes

1. Assembly to be identified with Glenair's name, part number, and date code, space permitting
2. EMI Filtered receptacle connector designed to meet requirements of MIL-STD-2120 and Glenair Series 79 specifications. Unless otherwise specified herein, refer to Glenair specification 799-008 for additional performance characteristics.
3. All contacts to have identical filter value. Other filter arrangements available, contact factory
4. See pages G-26 to G-31 for PCB hole patterns
5. Dielectric Withstanding Voltage: 500 VDC (Filter Class X, Y, Z are 250 VDC)
6. Insulation Resistance:
5,000 MEGOHMS min @ 200VDC for Class A, B, C, D, E, F, G & J.
1,000 MEGOHMS @ 83VDC for classes, X, Y, & Z
7. Current Carrying Capacity
23 Gage - 5 Amps max. for all layouts
16 Gage - 7.5 Amps max. for combo layouts / 13 Amps max. for all-power layouts
12 Gage - 13 Amps max. for combo layouts / 23 Amps max. for all-power layouts
8. Other filter styles (C-L, L-C, Unbalanced Pi, Multi-Stage, Multi-Value) are available. Please consult factory with your requirements.

Materials/Finishes:

Insulators - High Grade Rigid Dielectric / N.A.
 Interfacial Seal - Fluorosilicone Elastomer / N.A.
 Contacts - Copper Alloy / 50 microinches Gold over Nickel
 Mating Hardware - 300 Series Stainless Steel / Passivated
 EMI Gasket - Silver-Filled Fluorosilicone, CHO-SEAL 1287

Dimensions in inches (millimeters) and are subject to change without notice.

240-790-028
 Series 79 Filtered Receptacle
 Rear Panel Mount with Straight PC Tails



Table I: Contact Arrangements

Layout	Contact Quantity			Face View
	#23	#16	#12	
A-5	5			
B-2P2		2		
B-9	9			
C-13	13			
D-15	15			
D-3P3		3		
D-7P2	5	2		
E-11P2	9	2		
E-19	19			
E-7P3	4	3		
F-15P2	13	2		
F-23	23			
F-5P5		5		
G-33	33			
H-10P4	6		4	
H-29P7	22	7		
H-36P2	34		2	
H-54P2	52	2		
H-5P5			5	
H-66	66			
J-17P4	13	4		
J-25P2	23	2		
J-33	33			
J-7P7		7		
K-27P4	23	4		
K-35P2	33	2		
K-43	43			
K-9P9		9		
L-6P6			6	
L-78	78			
M-102	102			

Table II: Capacitor Array Code / Capacitance Range

Class	Pi - Circuit (pF)	C - Circuit (pF)
X*†	160,000 - 240,000	80,000 - 120,000
Y*	80,000 - 120,000	40,000 - 60,000
Z*	60,000 - 90,000	30,000 - 45,000
A	38,000 - 56,000	19,000 - 28,000
B	32,000 - 45,000	16,000 - 22,500
C	18,000 - 33,000	9,000 - 16,500
D	8,000 - 12,000	4,000 - 6,000
E	3,300 - 5,000	1,650 - 2,500
F	800 - 1,300	400 - 650
G	400 - 600	200 - 300
J	70-120	35-60

* Filter Classes X, Y and Z are 250 VDC.
 All others are 500 VDC
 † Class X filters not available for insert arrangements with 3 or more rows of contacts

Blind mate

SHELL SIZES A, B, C, D, E, F, G, J, K

± .030 (0.76) Allowable misalignment from centerline

SHELL SIZES H, L

± .040 (1.02) Allowable misalignment from centerline

SHELL SIZE M

± .050 (1.27) Allowable misalignment from centerline



Table III: Hardware Option

N No Mating Hardware		Connector supplied with blind tapped holes. .150" (3.8 mm) minimum depth. Shell size M has #8-32 UNC-2B thread. Shell sizes H and L have #6-32 UNC-2B thread. All other sizes have #4-40 UNC-2B thread.
P Jackposts		Connector is supplied with non-removable stainless steel jackposts. Shell size M has 6-32-UNC thread. Shell sizes H and L have #4-40 UNC-2B thread. All other sizes have #2-56 UNC-2B thread.
G Guide Pins		Connector is supplied with stainless steel non-removable guide pins for blind mate applications. Mates with type "S" guide sockets on corresponding plug connector.
S Guide Sockets		Connector is supplied with stainless steel non-removable bushings for blind mate applications. Mates with type "G" guide pins on corresponding plug connector.

Dimensions in inches (millimeters) and are subject to change without notice.



240-790-028P SHELL SIZE A, B, C, D, E, F, J AND K DIMENSIONS

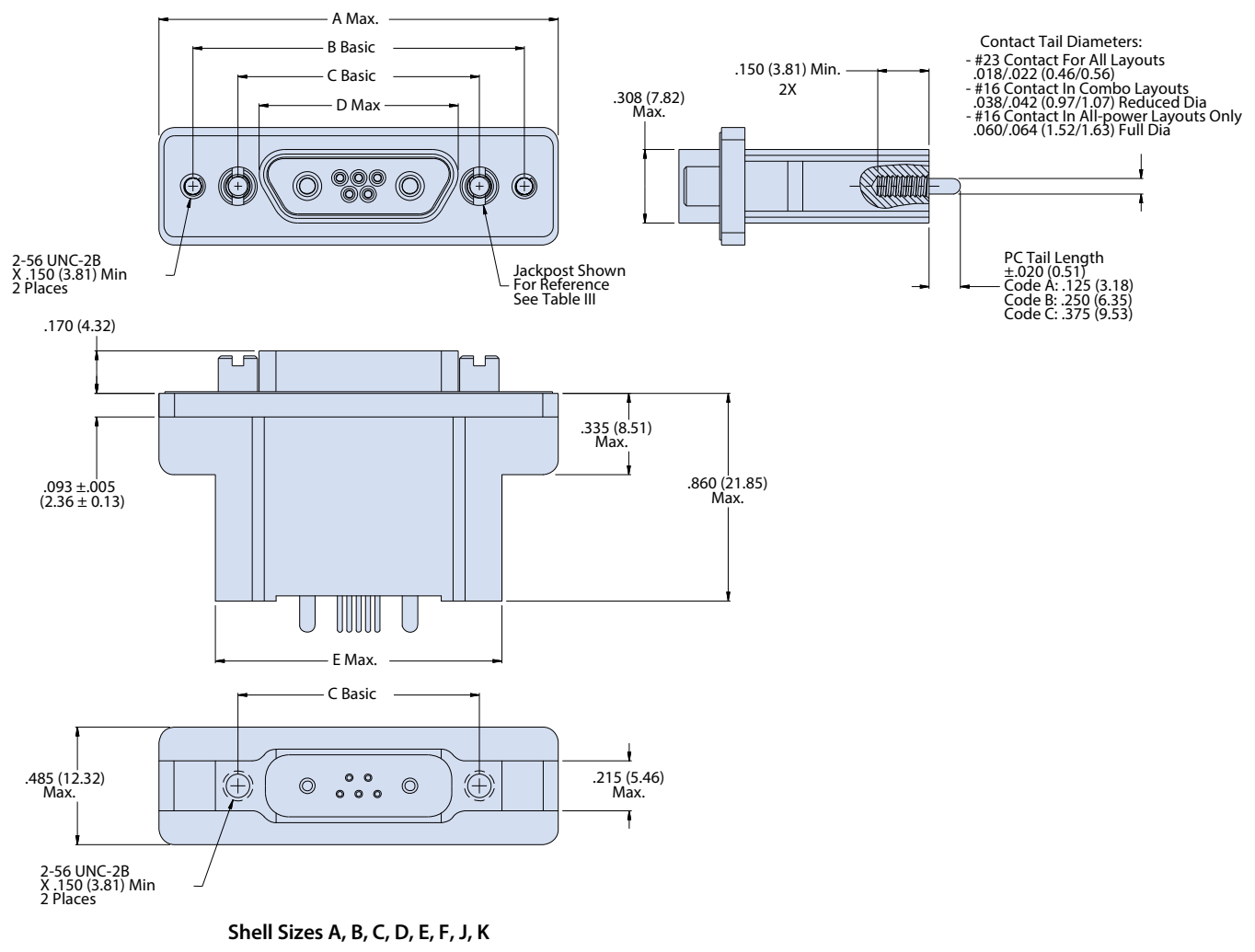

790-028P Dimensions for Size A-F, J and K										
Shell Size	A Max.		B Basic		C Basic		D Max.		E Max.	
	In.	mm.	In.	mm.	In.	mm.	In.	mm.	In.	mm.
A	1.211	30.76	.925	23.50	.565	14.35	.401	10.19	.760	19.30
B	1.361	34.57	1.075	27.31	.715	18.16	.551	14.00	.910	23.11
C	1.511	38.38	1.225	31.12	.865	21.97	.701	17.81	1.060	26.92
D	1.611	40.92	1.325	33.66	.965	24.51	.801	20.35	1.160	29.46
E	1.761	44.73	1.475	37.47	1.115	28.32	.951	24.16	1.310	33.27
F	1.911	48.54	1.625	41.28	1.265	32.13	1.101	27.96	1.460	37.08
J	2.261	57.43	1.975	50.17	1.615	41.02	1.460	37.08	1.810	45.97
K	2.661	67.59	2.375	60.33	2.015	51.18	1.860	47.24	2.210	56.13

Dimensions in inches (millimeters) and are subject to change without notice.

240-790-028
 Series 79 Filtered Receptacle
 Rear Panel Mount with Straight PC Tails



Series 79
 Micro-Crimp

240-790-028P SHELL SIZE G DIMENSIONS

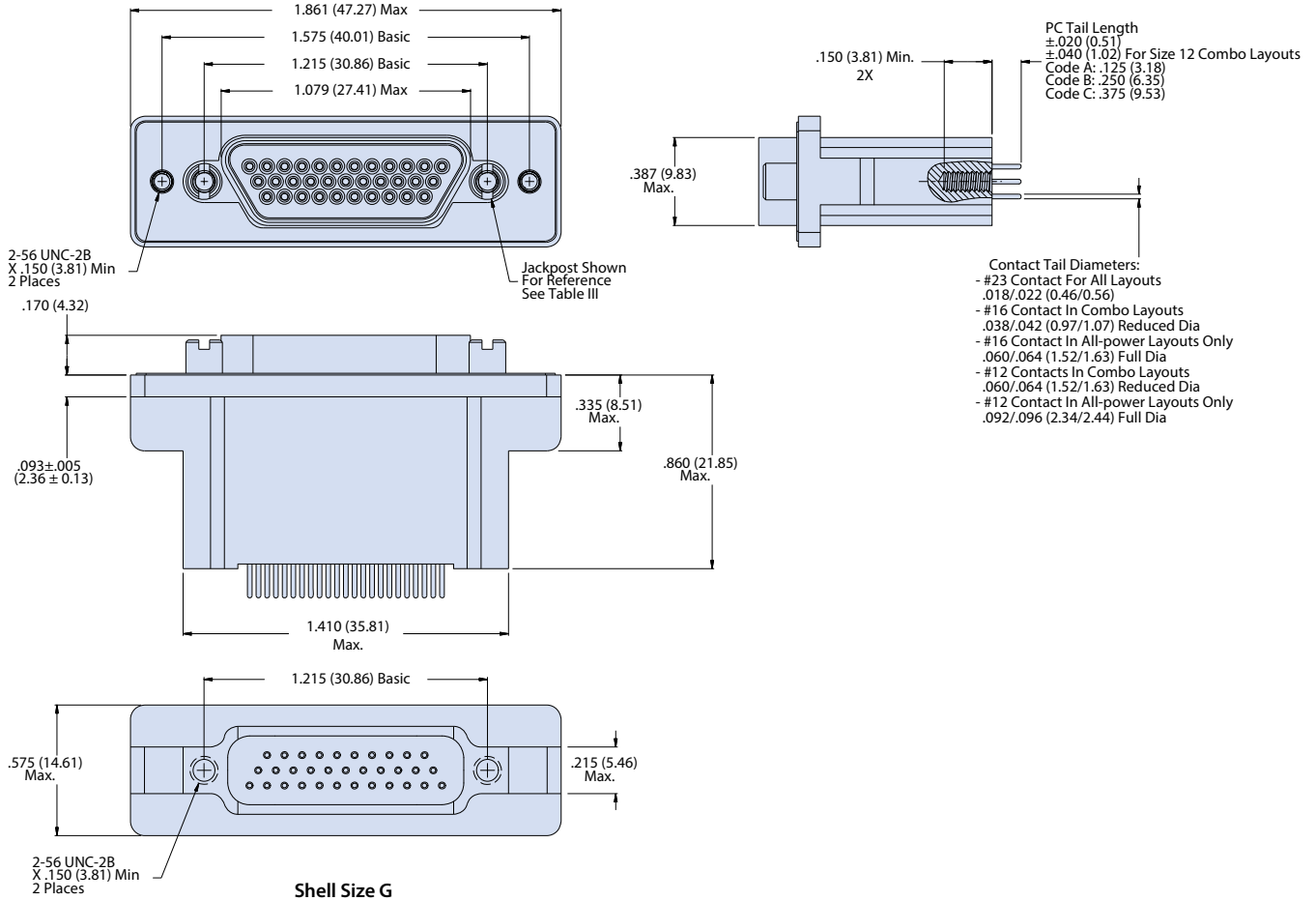

Dimensions in inches (millimeters) and are subject to change without notice.

© 2013 Glenair, Inc.

U.S. CAGE Code 06324

Printed in U.S.A.



240-790-028P SHELL SIZE H AND L DIMENSIONS

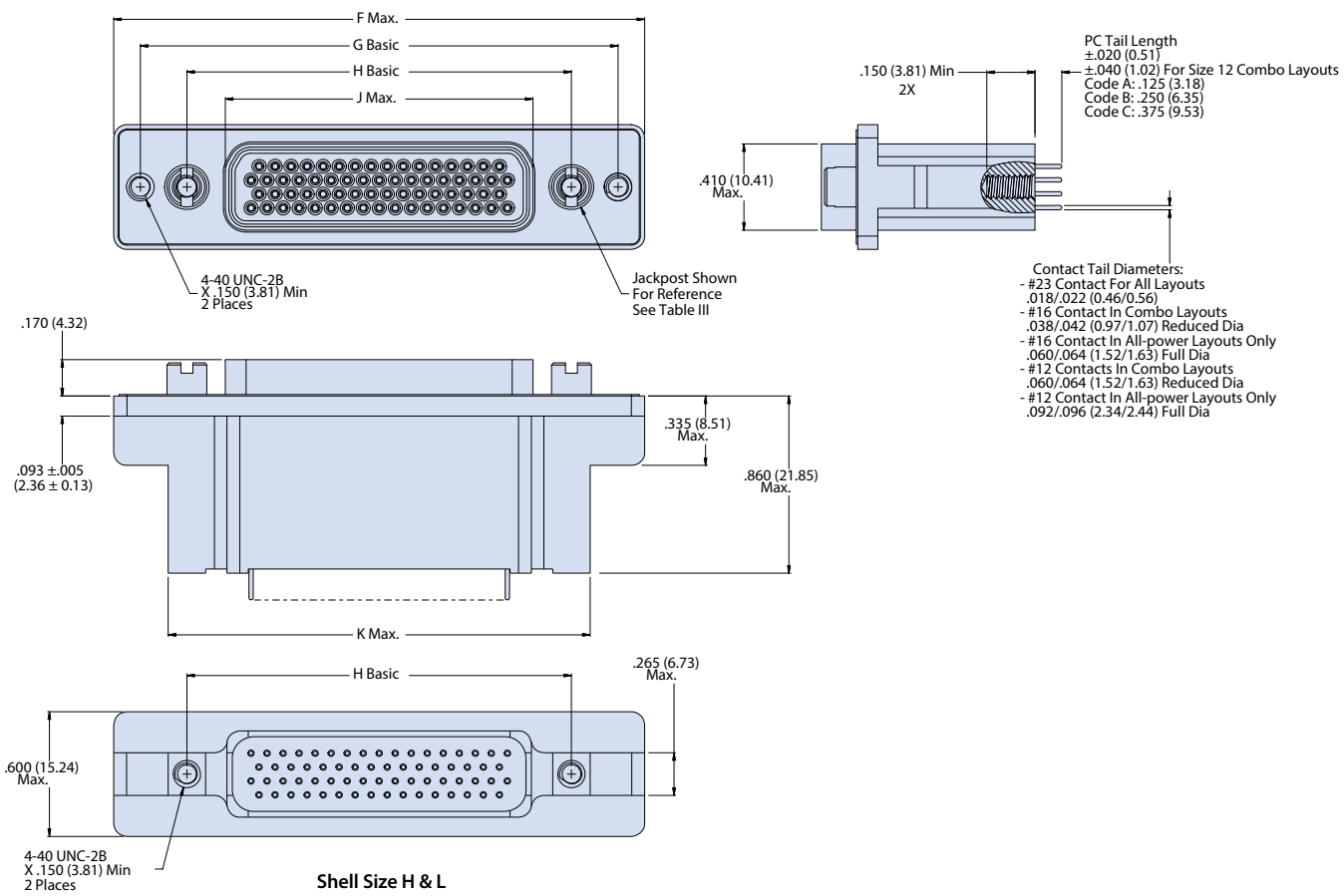

Shell Size H & L

790-028P Size H & L Dimensions										
Shell Size	F Max.		G Basic		H Basic		J Max.		K Max.	
	In.	mm.	In.	mm.	In.	mm.	In.	mm.	In.	mm.
H	2.500	63.50	2.236	56.79	1.800	45.72	1.450	36.83	2.045	51.94
L	2.736	69.49	2.472	62.79	2.036	51.71	1.686	42.82	2.281	57.94

Dimensions in inches (millimeters) and are subject to change without notice.

240-790-028
 Series 79 Filtered Receptacle
 Rear Panel Mount with Straight PC Tails



240-790-028P SHELL SIZE M DIMENSIONS

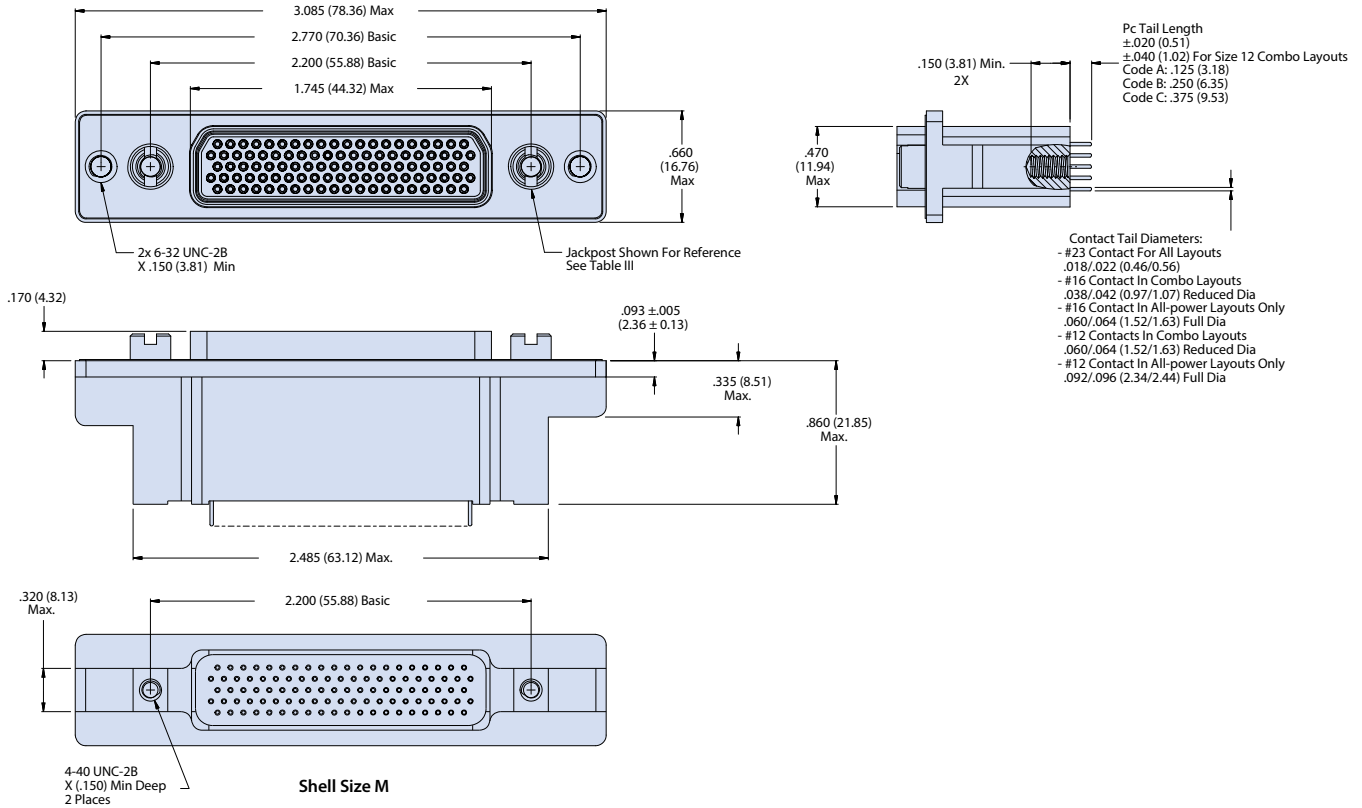

Dimensions in inches (millimeters) and are subject to change without notice.



240-790-029
Series 79 Filtered Plug
Rear Panel Mount with Straight PC Tails

How To Order Filter Series 79 Connectors

Sample Part Number	240-790-029	S	H-66	ME	E	P	D	S	A
Series	240-790-029								
Contact Type	S - Socket Contacts								
Insert Arrangement	(See Table I)								
Shell Material/Finish	Aluminum Shell ME - Electroless Nickel MT - Nickel-PTFE E - Chem Film Z2 - Gold UC - Zinc Cobalt with Black Chromate J - Cadmium with Yellow Chromate NF - Cad/O.D. over Electroless Nickel								
EMI Spring	E - With EMI Spring N - No EMI Spring								
Filter Type	C - C Filter P - Pi Filter								
Filter Class	X, Y, Z, A, B, C, D, E, F, G, J (See Table II)								
Mating Hardware Options	P - Jackposts G - Male Guide Pins S - Female Guide Sockets N - No Mating Hardware (See Table)								
PC Tail Length	A - .125" (3.18) B - .250" (6.35) C - .375" (9.53)								

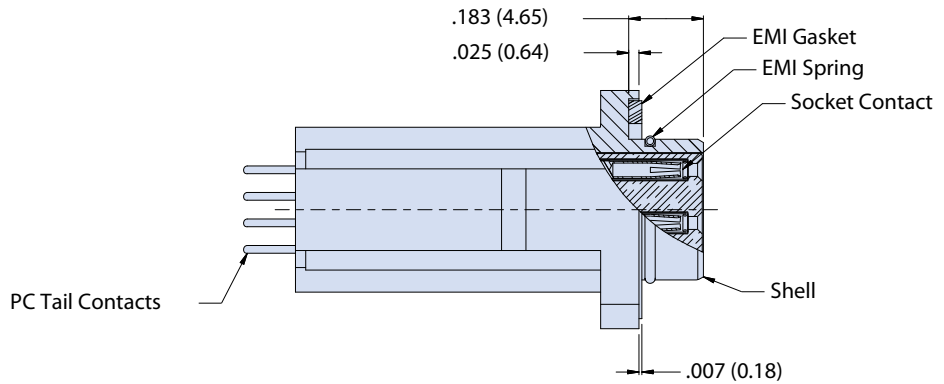
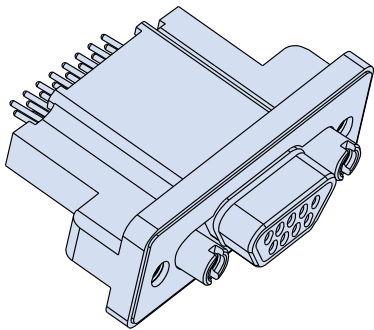

Notes

1. Assembly to be identified with Glenair's name, part number, and date code, space permitting
2. Ground spring is not compatible with Zinc Cobalt or Cadmium platings. Ground spring is only available with Nickel, Teflon Nickel, Gold, or Chem Film plating on the shell.
3. EMI Filtered plug connector designed to meet requirements of MIL-STD-2120 and Glenair Series 79 specifications. Unless otherwise specified herein, refer to Glenair specification 799-008 for additional performance characteristics.
4. All contacts to have identical filter value. Other filter arrangements available, contact factory
5. See pages G-32 to G-37 for PCB hole patterns
6. Dielectric Withstanding Voltage: 500 VDC (Filter Class X, Y, Z are 250 VDC)
7. Insulation Resistance: 5,000 MEGOHMS min @ 200VDC for

8. Current Carrying Capacity
23 Gage - 5 Amps max. for all layouts
16 Gage - 7.5 Amps max. for combo layouts / 13 Amps max. for all-power layouts
12 Gage - 13 Amps max. for combo layouts / 23 Amps max. for all-power layouts
9. Other filter styles (C-L, L-C, Unbalanced Pi, Multi-Stage, Multi-Value) are available. Please consult factory with your requirements.

Materials/Finishes:

Insulators - High Grade Rigid Dielectric / N.A.
Contacts - Copper Alloy / 50 microinches Gold over Nickel
Mating Hardware - 300 Series Stainless Steel / Passivated
EMI Gasket - Silver-Filled Fluorosilicone, CHO-SEAL 1287

Dimensions in inches (millimeters) and are subject to change without notice.

240-790-029
 Series 79 Filtered Plug
 Rear Panel Mount with Straight PC Tails



Table I: Contact Arrangements

Layout	Contact Quantity			Face View
	#23	#16	#12	
A-5	5			
B-2P2		2		
B-9	9			
C-13	13			
D-15	15			
D-3P3		3		
D-7P2	5	2		
E-11P2	9	2		
E-19	19			
E-7P3	4	3		
F-15P2	13	2		
F-23	23			
F-5P5		5		
G-33	33			
H-10P4	6		4	
H-29P7	22	7		
H-36P2	34		2	
H-54P2	52	2		
H-5P5			5	
H-66	66			
J-17P4	13	4		
J-25P2	23	2		
J-33	33			
J-7P7		7		
K-27P4	23	4		
K-35P2	33	2		
K-43	43			
K-9P9		9		
L-6P6			6	
L-78	78			
M-102	102			

Table II: Capacitor Array Code / Capacitance Range

Class	Pi - Circuit (pF)	C - Circuit (pF)
X*†	160,000 - 240,000	80,000 - 120,000
Y*	80,000 - 120,000	40,000 - 60,000
Z*	60,000 - 90,000	30,000 - 45,000
A	38,000 - 56,000	19,000 - 28,000
B	32,000 - 45,000	16,000 - 22,500
C	18,000 - 33,000	9,000 - 16,500
D	8,000 - 12,000	4,000 - 6,000
E	3,300 - 5,000	1,650 - 2,500
F	800 - 1,300	400 - 650
G	400 - 600	200 - 300
J	70-120	35-60

* Filter Classes X, Y and Z are 250 VDC.
 All others are 500 VDC
 † Class X filters not available for insert arrangements with 3 or more rows of contacts

Blind mate

SHELL SIZES A, B, C, D, E, F, G, J, K

± .030 (0.76) Allowable misalignment from centerline

SHELL SIZES H, L

± .040 (1.02) Allowable misalignment from centerline

SHELL SIZE M

± .050 (1.27) Allowable misalignment from centerline



Table III: Hardware Option

N No Mating Hardware		Connector supplied with blind tapped holes. .150" (3.8 mm) minimum depth. Shell size M has #8-32 UNC-2B thread. Shell sizes H and L have #6-32 UNC-2B thread. All other sizes have #4-40 UNC-2B thread.
P Jackposts		Connector is supplied with non-removable stainless steel jackposts. Shell size M has 6-32-UNC thread. Shell sizes H and L have #4-40 UNC-2B thread. All other sizes have #2-56 UNC-2B thread.
G Guide Pins		Connector is supplied with stainless steel non-removable guide pins for blind mate applications. Mates with type "S" guide sockets on corresponding plug connector.
S Guide Sockets		Connector is supplied with stainless steel non-removable bushings for blind mate applications. Mates with type "G" guide pins on corresponding plug connector.

Dimensions in inches (millimeters) and are subject to change without notice.



240-790-029S SHELL SIZE A, B, C, D, E, F, J AND K DIMENSIONS

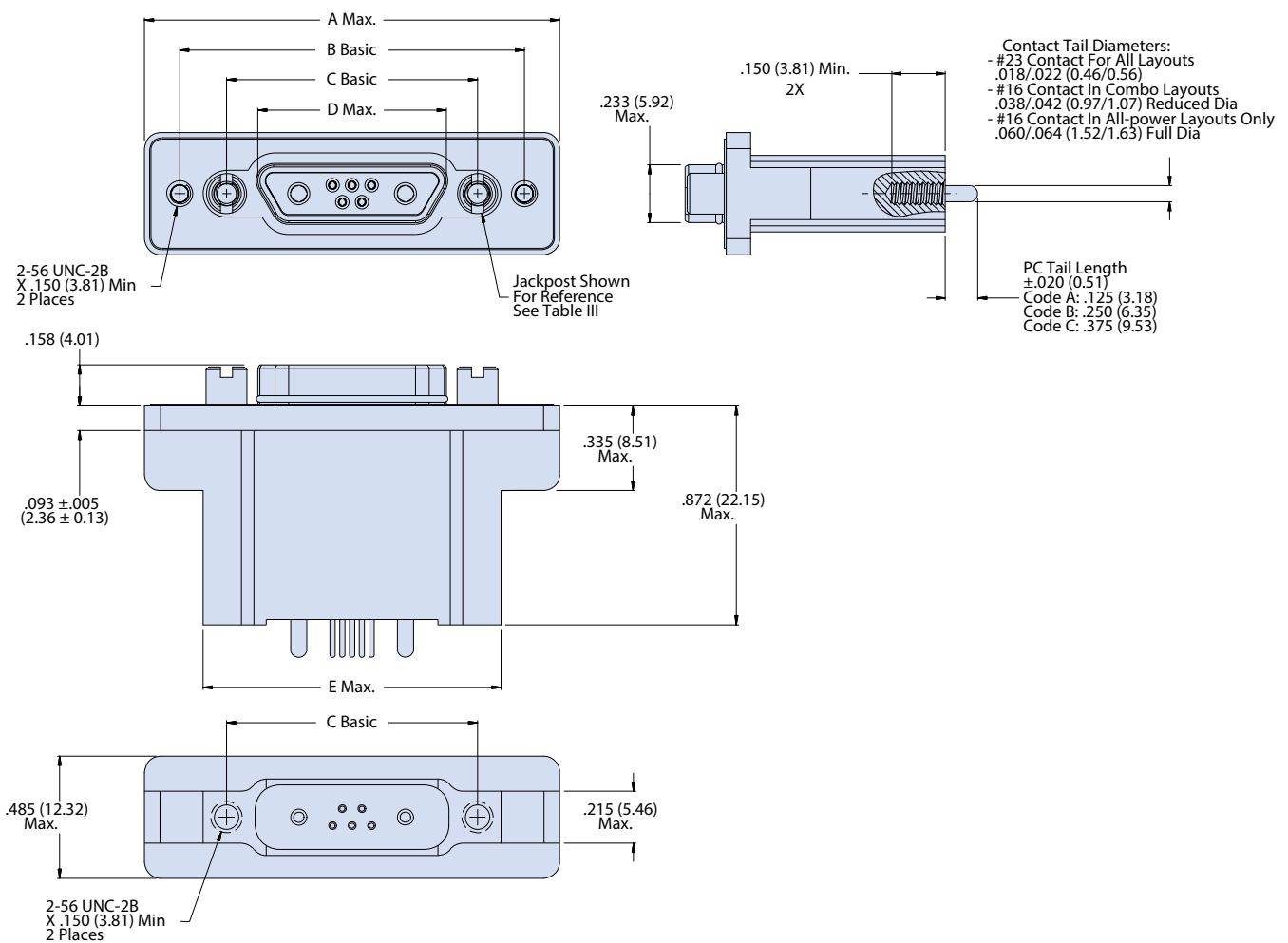

Shell Sizes A, B, C, D, E, F, J, K

790-029S Dimensions for Size A-F, J and K										
Shell Size	A Max.		B Basic		C Basic		D Max.		E Max.	
	In.	mm.	In.	mm.	In.	mm.	In.	mm.	In.	mm.
A	1.211	30.76	.925	23.50	.565	14.35	.335	8.51	.760	19.30
B	1.361	34.57	1.075	27.31	.715	18.16	.485	12.32	.910	23.11
C	1.511	38.38	1.225	31.12	.865	21.97	.635	16.13	1.060	26.92
D	1.611	40.92	1.325	33.66	.965	24.51	.735	18.67	1.160	29.46
E	1.761	44.73	1.475	37.47	1.115	28.32	.885	22.48	1.310	33.27
F	1.911	48.54	1.625	41.28	1.265	32.13	1.035	26.29	1.460	37.08
J	2.261	57.43	1.975	50.17	1.615	41.02	1.390	35.31	1.810	45.97
K	2.661	67.59	2.375	60.33	2.015	51.18	1.795	45.59	2.210	56.13

Dimensions in inches (millimeters) and are subject to change without notice.

240-790-029
 Series 79 Filtered Plug
 Rear Panel Mount with Straight PC Tails



Series 79
 Micro-Crimp

240-790-029S SHELL SIZE G DIMENSIONS

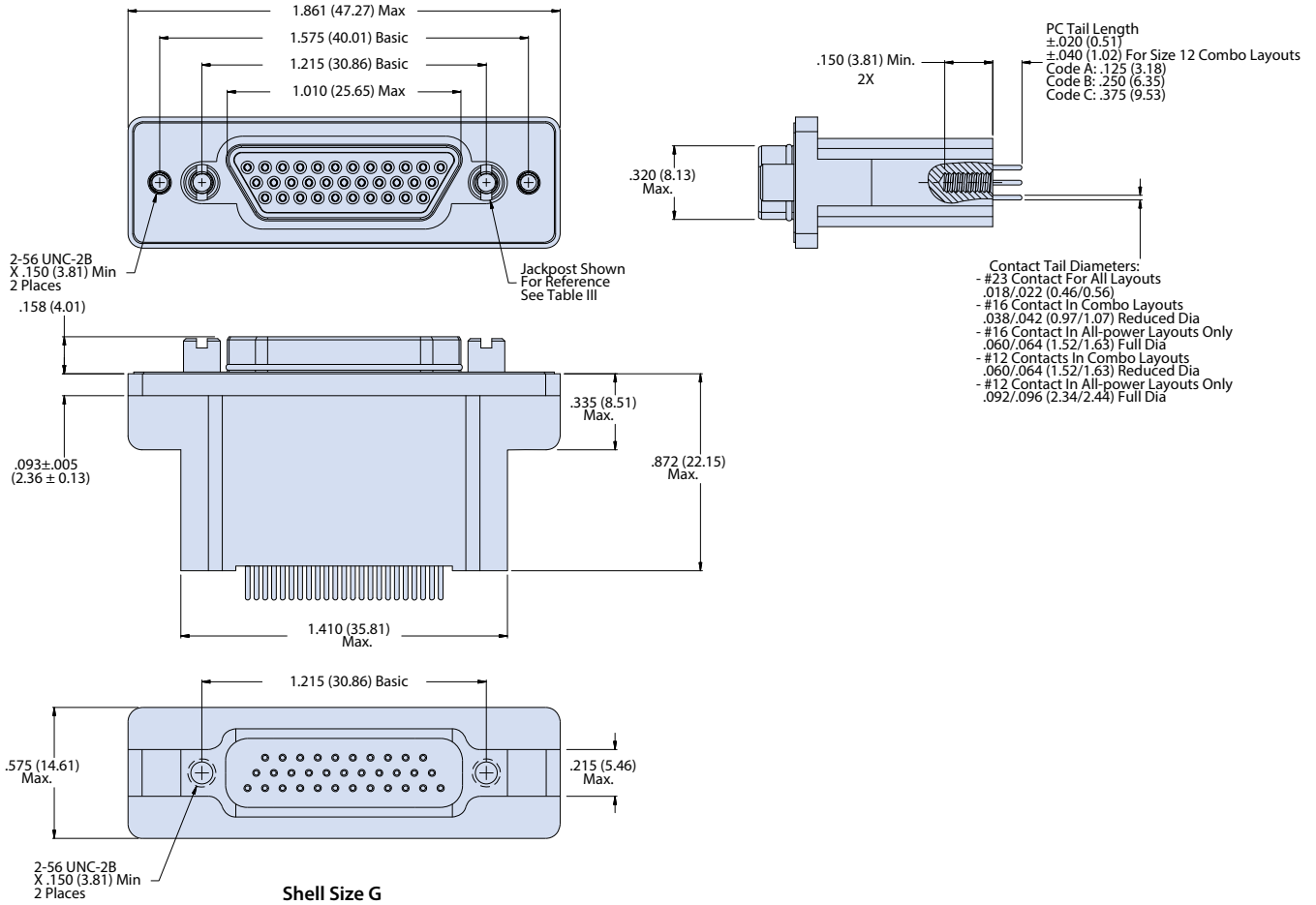

Dimensions in inches (millimeters) and are subject to change without notice.

© 2013 Glenair, Inc.

U.S. CAGE Code 06324

Printed in U.S.A.



240-790-029S SHELL SIZE H AND L DIMENSIONS

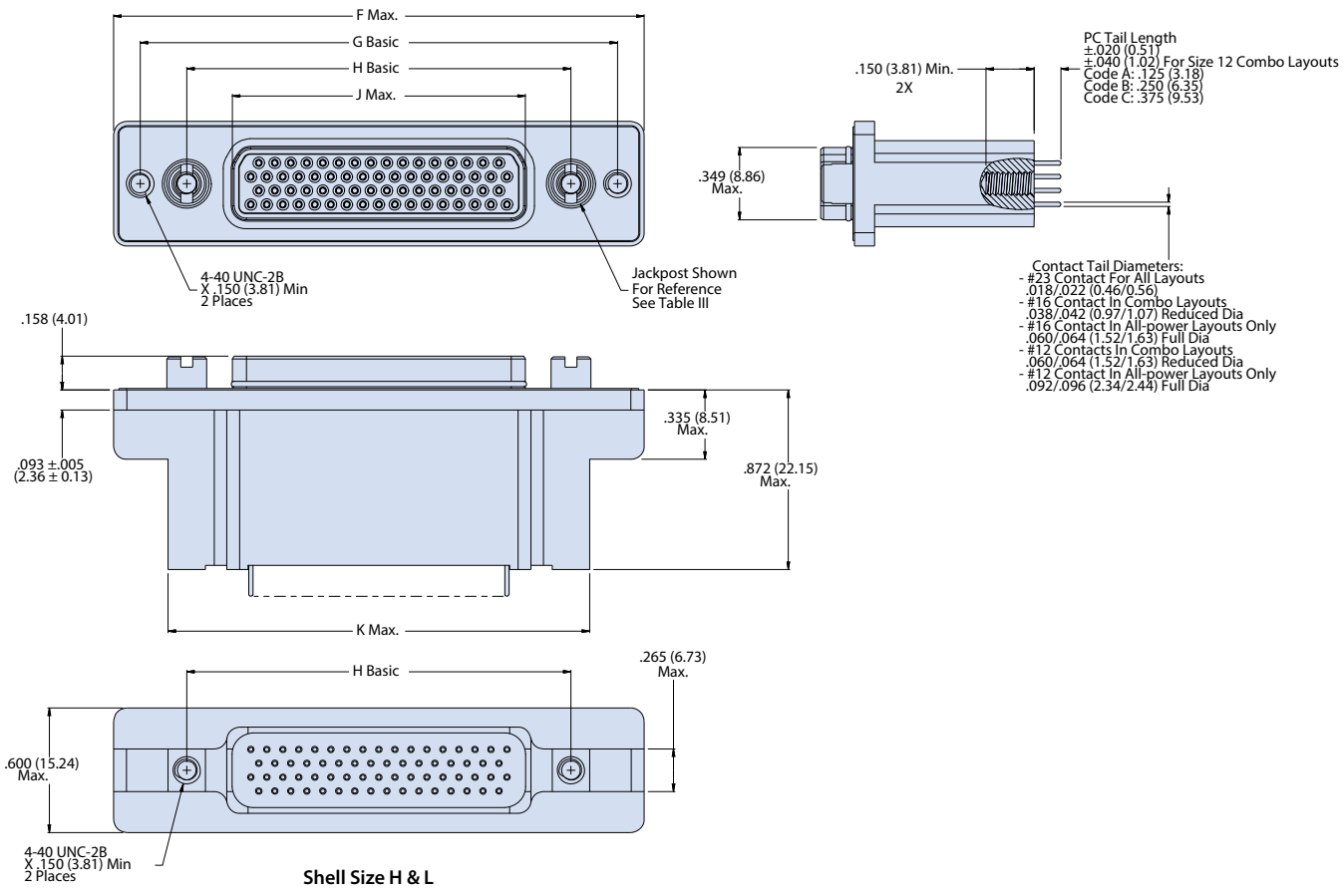

790-029S Size H & L Dimensions										
Shell Size	F Max.		G Basic		H Basic		J Max.		K Max.	
	In.	mm.	In.	mm.	In.	mm.	In.	mm.	In.	mm.
H	2.500	63.50	2.236	56.79	1.800	45.72	1.385	35.18	2.045	51.94
L	2.736	69.49	2.472	62.79	2.036	51.71	1.623	41.22	2.281	57.94

Dimensions in inches (millimeters) and are subject to change without notice.

240-790-029
 Series 79 Filtered Plug
 Rear Panel Mount with Straight PC Tails



Series 79
 Micro-Crimp

240-790-029S SHELL SIZE M DIMENSIONS

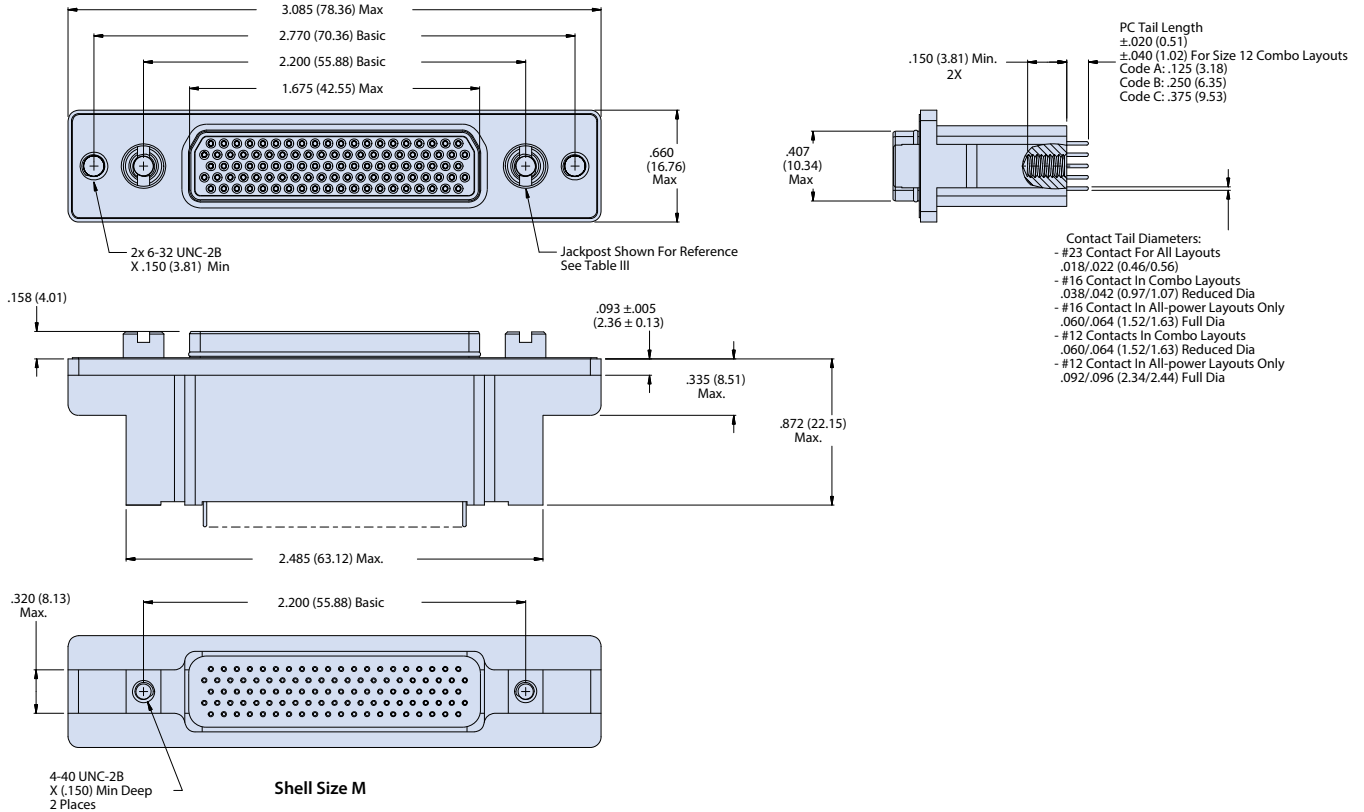

Dimensions in inches (millimeters) and are subject to change without notice.

© 2013 Glenair, Inc.

U.S. CAGE Code 06324

Printed in U.S.A.



240-790-043
Series 79 Filtered Receptacle
Vertical PCB Mount with Straight PC Tails

How To Order Filter Series 79 Connectors

Sample Part Number	240-790-043	P	H-66	ME	P	D	P	A
Series	240-790-043							
Contact Type	P - Pin Contacts							
Insert Arrangement	(See Table I)							
Shell Material/Finish	Aluminum Shell ME - Electroless Nickel MT - Nickel-PTFE E - Chem Film Z2 - Gold UC - Zinc Cobalt with Black Chromate J - Cadmium with Yellow Chromate NF - Cad/O.D. over Electroless Nickel							
Filter Type	C - C Filter P - Pi Filter							
Filter Class	X, Y, Z, A, B, C, D, E, F, G, J (See Table II)							
Mating Hardware Options	P - Jackposts N - No Mating Hardware (See Table)							
PC Tail Length	A - .125" (3.18) B - .250" (6.35) C - .375" (9.53)							

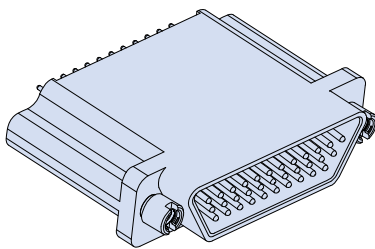

PC Tail Contacts

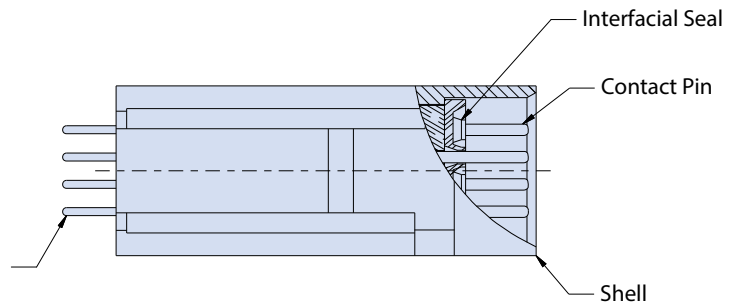

Notes

1. Assembly to be identified with Glenair's name, part number, and date code, space permitting
2. EMI Filtered receptacle connector designed to meet requirements of MIL-STD-2120 and Glenair Series 79 specifications. Unless otherwise specified herein, refer to Glenair specification 799-008 for additional performance characteristics.
3. All contacts to have identical filter value. Other filter arrangements available, contact factory
4. Dielectric Withstanding Voltage: 500 VDC (Filter Class X, Y, Z are 250 VDC)
5. See pages G-26 to G-31 for PCB hole patterns
6. Insulation Resistance:
5,000 MEGOHMS min @ 200VDC for Class A, B, C, D, E, F, G & J.
1,000 MEGOHMS @ 83VDC for classes, X, Y, & Z

7. Current Carrying Capacity
23 Gage - 5 Amps max. for all layouts
16 Gage - 7.5 Amps max. for combo layouts / 13 Amps max. for all-power layouts
12 Gage - 13 Amps max. for combo layouts / 23 Amps max. for all-power layouts
8. Other filter styles (C-L, L-C, Unbalanced Pi, Multi-Stage, Multi-Value) are available. Please consult factory with your requirements.

Materials/Finishes:

Insulators - High Grade Rigid Dielectric / N.A.
Interfacial Seal - Fluorosilicone Elastomer / N.A.
Contacts - Copper Alloy / 50 microinches Gold over Nickel
Mating Hardware - 300 Series Stainless Steel / Passivated

Dimensions in inches (millimeters) and are subject to change without notice.

240-790-043
 Series 79 Filtered Receptacle
 Vertical PCB Mount with Straight PC Tails



Table I: Contact Arrangements

Layout	Contact Quantity			Face View
	#23	#16	#12	
A-5	5			
B-2P2		2		
B-9	9			
C-13	13			
D-15	15			
D-3P3		3		
D-7P2	5	2		
E-11P2	9	2		
E-19	19			
E-7P3	4	3		
F-15P2	13	2		
F-23	23			
F-5P5		5		
G-33	33			
H-10P4	6		4	
H-29P7	22	7		
H-36P2	34		2	
H-54P2	52	2		
H-5P5			5	
H-66	66			
J-17P4	13	4		
J-25P2	23	2		
J-33	33			
J-7P7		7		
K-27P4	23	4		
K-35P2	33	2		
K-43	43			
K-9P9		9		
L-6P6			6	
L-78	78			
M-102	102			

Table II: Capacitor Array Code / Capacitance Range

Class	Pi - Circuit (pF)	C - Circuit (pF)
X*†	160,000 - 240,000	80,000 - 120,000
Y*	80,000 - 120,000	40,000 - 60,000
Z*	60,000 - 90,000	30,000 - 45,000
A	38,000 - 56,000	19,000 - 28,000
B	32,000 - 45,000	16,000 - 22,500
C	18,000 - 33,000	9,000 - 16,500
D	8,000 - 12,000	4,000 - 6,000
E	3,300 - 5,000	1,650 - 2,500
F	800 - 1,300	400 - 650
G	400 - 600	200 - 300
J	70-120	35-60

* Filter Classes X, Y and Z are 250 VDC. All others are 500 VDC
 † Class X filters not available for insert arrangements with 3 or more rows of contacts



Table III: Hardware Option

N No Mating Hardware		Connector supplied with blind tapped holes. .150" (3.8 mm) minimum depth. Shell size M has #8-32 UNC-2B thread. Shell sizes H and L have #6-32 UNC-2B thread. All other sizes have #4-40 UNC-2B thread.
P Jackposts		Connector is supplied with non-removable stainless steel jackposts. Shell size M has 6-32-UNC thread. Shell sizes H and L have #4-40 UNC-2B thread. All other sizes have #2-56 UNC-2B thread.

Dimensions in inches (millimeters) and are subject to change without notice.



240-790-043P SHELL SIZE A, B, C, D, E, F, J AND K DIMENSIONS

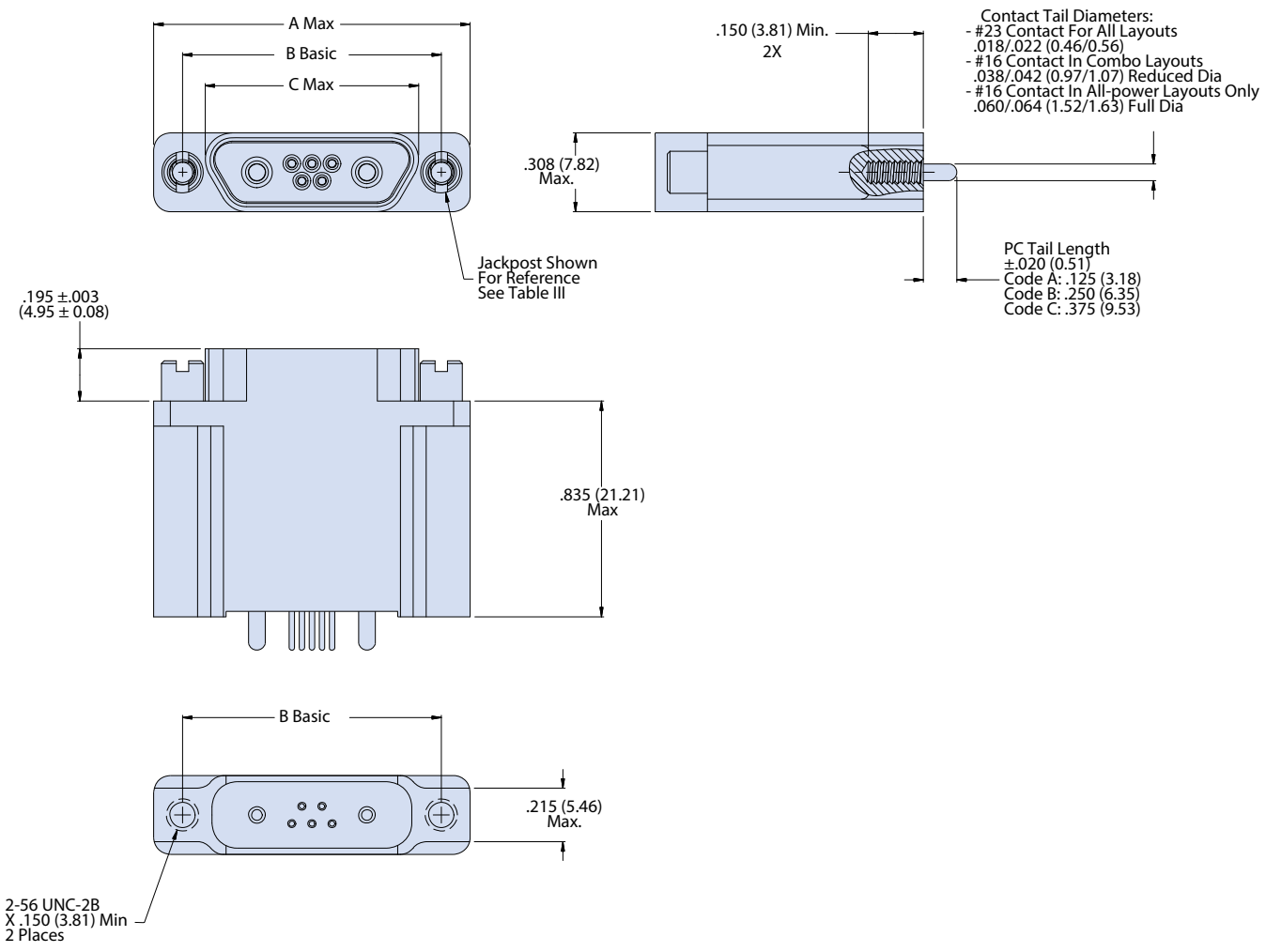

Shell Sizes A,B,C,D,E,F,J,K

790-043P Dimensions for Size A-F, J and K						
Shell Size	A Max.		B Basic		C Max	
	In.	mm.	In.	mm.	In.	mm.
A	.785	19.94	.565	14.35	.400	10.16
B	.935	23.75	.715	18.16	.551	14.00
C	1.085	27.56	.865	21.97	.701	17.81
D	1.185	30.10	.965	24.51	.801	20.35
E	1.335	33.91	1.115	28.32	.951	24.16
F	1.485	37.72	1.265	32.13	1.101	27.96
J	1.845	46.86	1.615	41.02	1.460	37.08
K	2.240	56.90	2.015	51.18	1.860	47.24

Dimensions in inches (millimeters) and are subject to change without notice.

240-790-043
 Series 79 Filtered Receptacle
 Vertical PCB Mount with Straight PC Tails



Series 79
 Micro-Crimp

240-790-043P SHELL SIZE G DIMENSIONS

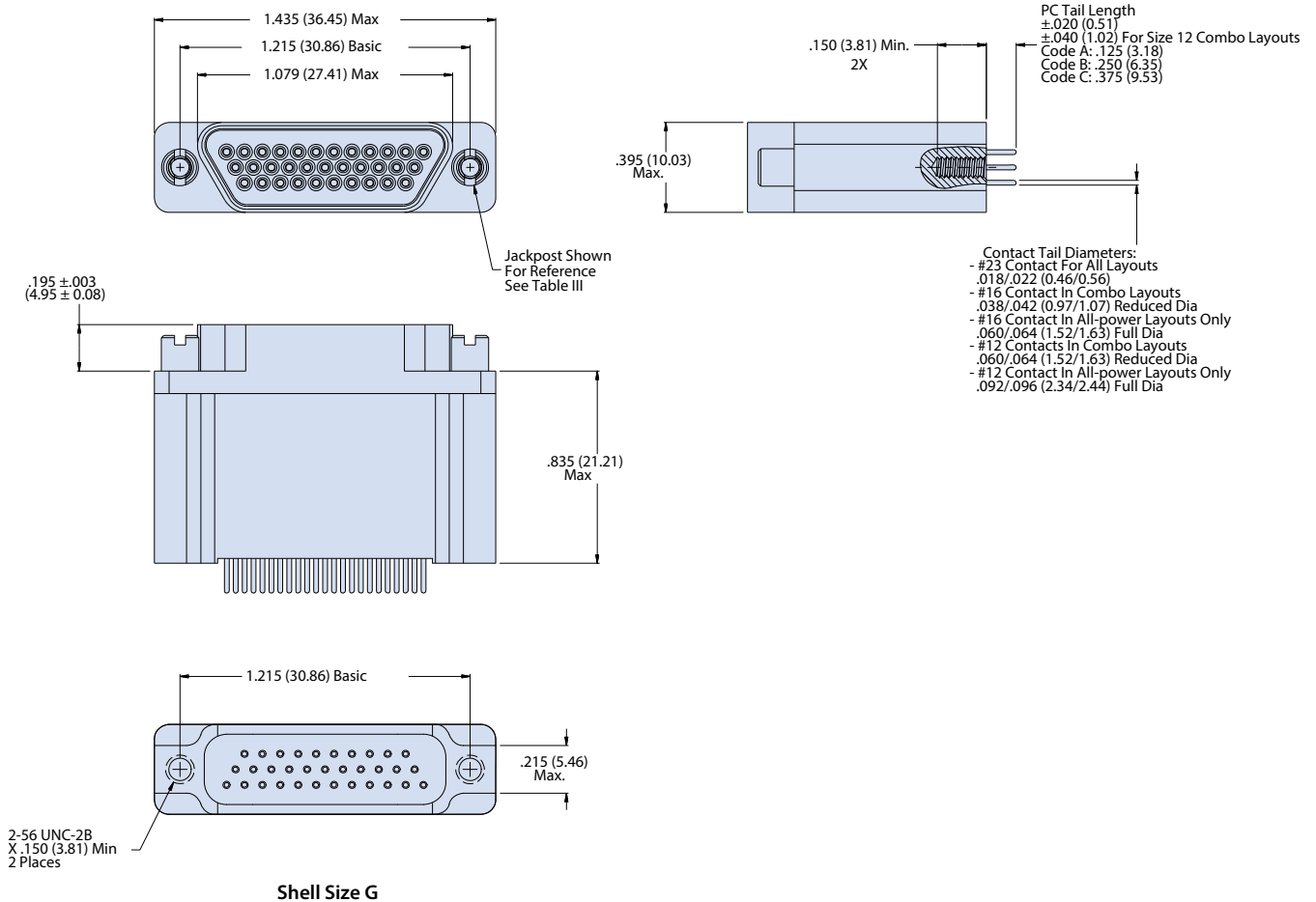

Dimensions in inches (millimeters) and are subject to change without notice.

© 2013 Glenair, Inc.

U.S. CAGE Code 06324

Printed in U.S.A.



240-790-043P SHELL SIZE H AND L DIMENSIONS

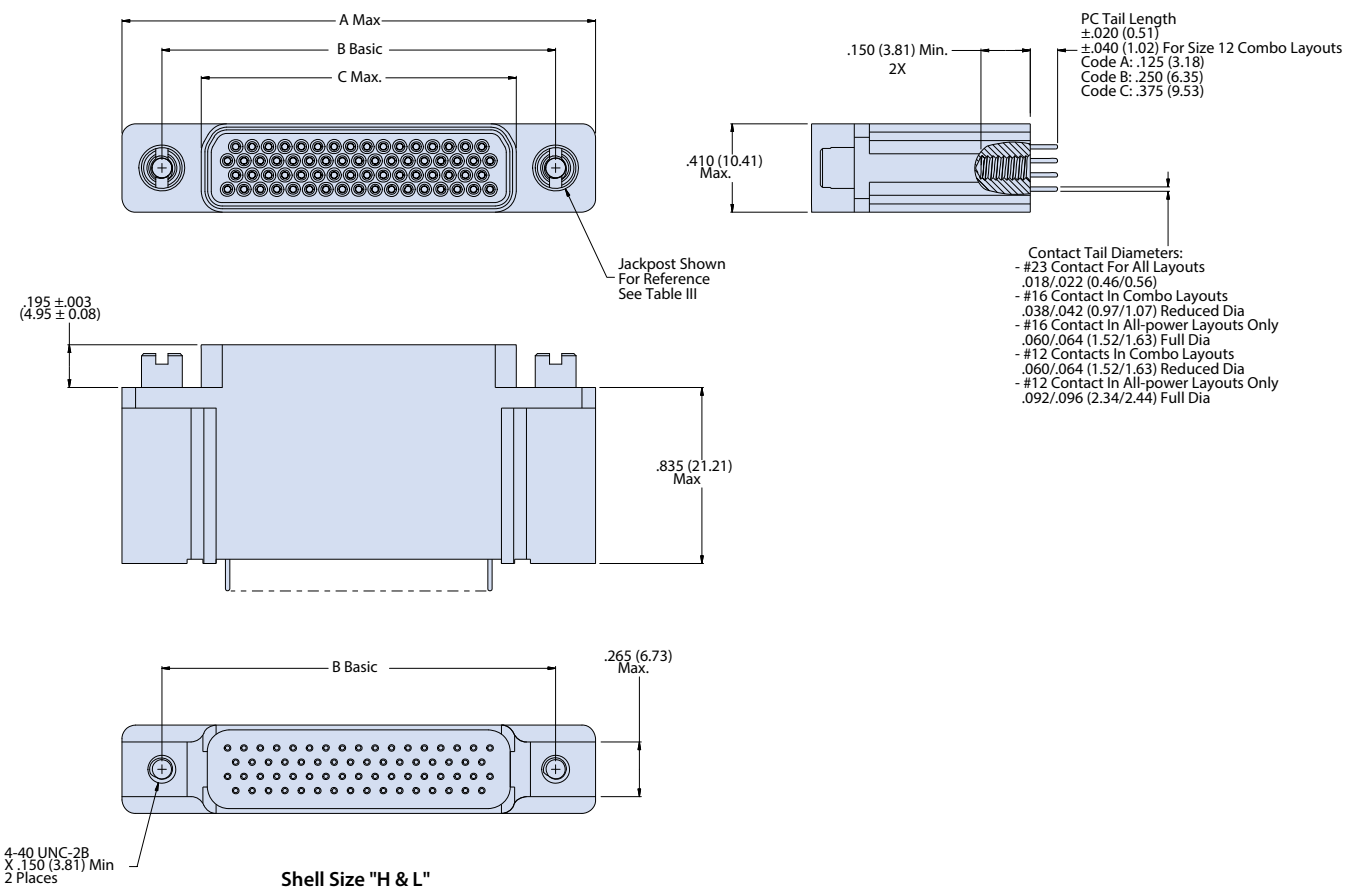

790-43P Size H & L Dimensions						
Shell Size	A Max.		B Basic		C Basic	
	In.	mm.	In.	mm.	In.	mm.
H	2.175	55.25	1.800	45.72	1.450	36.83
L	2.420	61.47	2.036	51.71	1.686	42.82

Dimensions in inches (millimeters) and are subject to change without notice.

240-790-043
 Series 79 Filtered Receptacle
 Vertical PCB Mount with Straight PC Tails



240-790-043P SHELL SIZE M DIMENSIONS

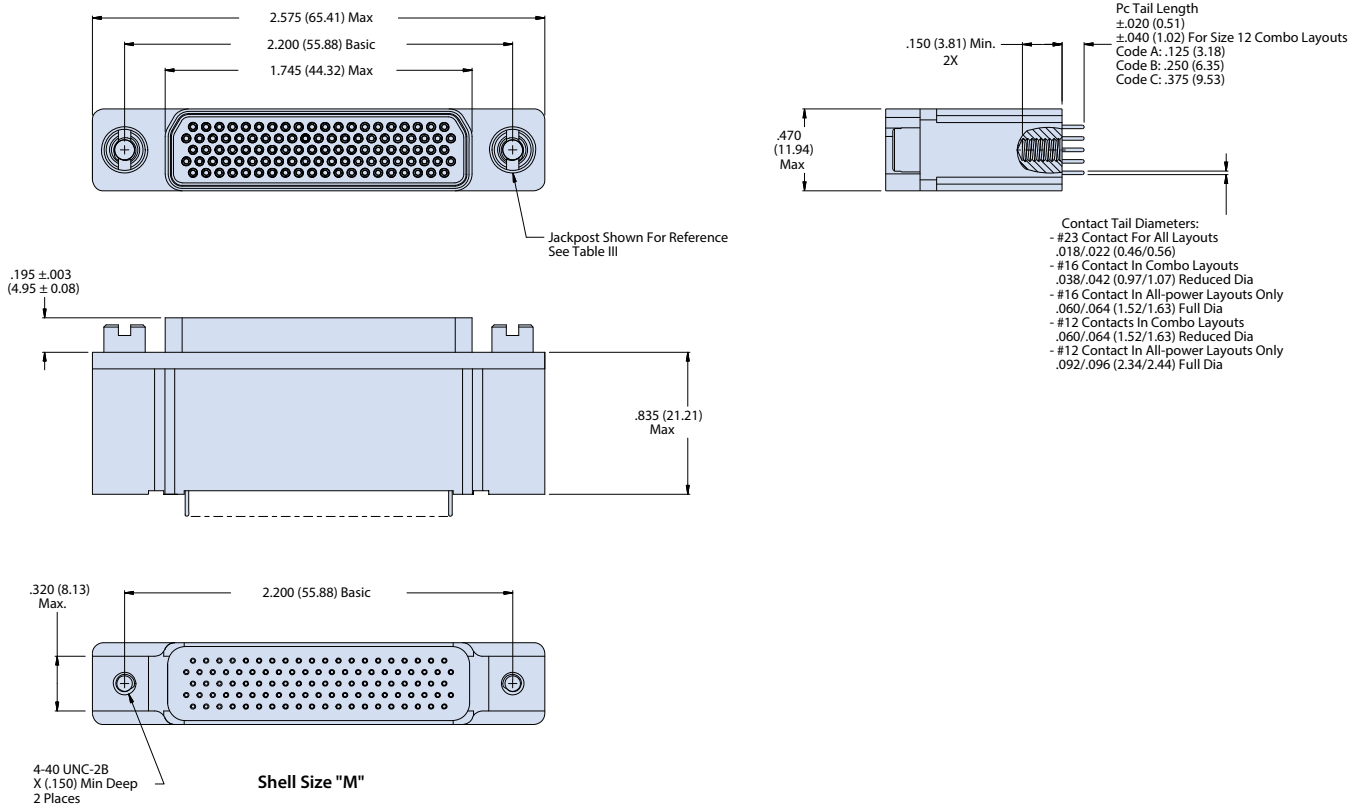

Dimensions in inches (millimeters) and are subject to change without notice.



240-790-044
Series 79 Filtered Plug
Vertical PCB Mount with Straight PC Tails

How To Order Filter Series 79 Connectors

Sample Part Number	240-790-044	S	H-66	ME	E	P	D	P	A
Series	240-790-044								
Contact Type	S - Socket Contacts								
Insert Arrangement	(See Table I)								
Shell Material/Finish	Aluminum Shell ME - Electroless Nickel MT - Nickel-PTFE E - Chem Film Z2 - Gold UC - Zinc Cobalt with Black Chromate J - Cadmium with Yellow Chromate NF - Cad/O.D. over Electroless Nickel								
EMI Spring	E - With EMI Spring N - No EMI Spring								
Filter Type	C - C Filter P - Pi Filter								
Filter Class	X, Y, Z, A, B, C, D, E, F, G, J (See Table II)								
Mating Hardware Options	P - Jackposts N - No Mating Hardware (See Table III)								
PC Tail Length	A - .125" (3.18) B - .250" (6.35) C - .375" (9.53)								

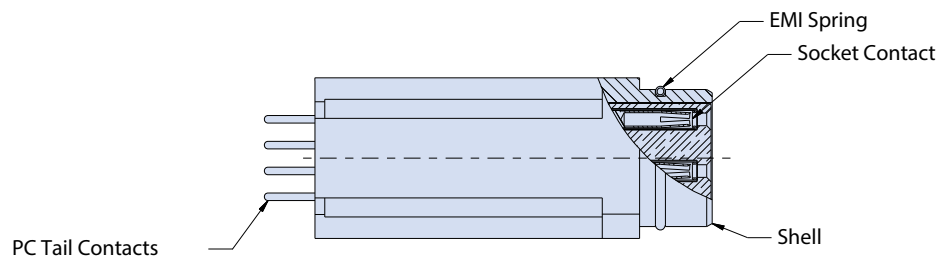
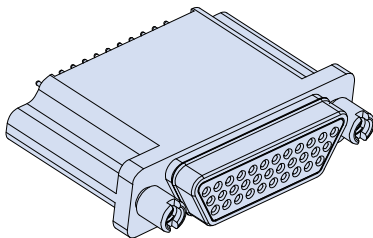

Notes

1. Assembly to be identified with Glenair's name, part number, and date code, space permitting
2. Ground spring is not compatible with Zinc Cobalt or Cadmium platings. Ground spring is only available with Nickel, Teflon Nickel, Gold, or Chem Film plating on the shell.
3. EMI Filtered plug connector designed to meet requirements of MIL-STD-2120 and Glenair Series 79 specifications. Unless otherwise specified herein, refer to Glenair specification 799-008 for additional performance characteristics.
4. All contacts to have identical filter value. Other filter arrangements available, contact factory
5. See pages G-32 to G-37 for PCB hole patterns
6. Dielectric Withstanding Voltage: 500 VDC (Filter Class X, Y, Z are 250 VDC)

7. Insulation Resistance:

5,000 MEGOHMS min @ 200VDC for Class A, B, C, D, E, F, G & J.
1,000 MEGOHMS @ 83VDC for classes, X, Y, & Z

8. Current Carrying Capacity

23 Gage - 5 Amps max. for all layouts
16 Gage - 7.5 Amps max. for combo layouts / 13 Amps max. for all-power layouts
12 Gage - 13 Amps max. for combo layouts / 23 Amps max. for all-power layouts

9. Other filter styles (C-L, L-C, Unbalanced Pi, Multi-Stage, Multi-Value) are available. Please consult factory with your requirements.

Materials/Finishes:

Insulators - High Grade Rigid Dielectric / N.A.
Contacts - Copper Alloy / 50 microinches Gold over Nickel
Mating Hardware - 300 Series Stainless Steel / Passivated

Dimensions in inches (millimeters) and are subject to change without notice.

240-790-044
Series 79 Filtered Plug
 Vertical PCB Mount with Straight PC Tails



Table I: Contact Arrangements

Layout	Contact Quantity			Face View
	#23	#16	#12	
A-5	5			
B-2P2		2		
B-9	9			
C-13	13			
D-15	15			
D-3P3		3		
D-7P2	5	2		
E-11P2	9	2		
E-19	19			
E-7P3	4	3		
F-15P2	13	2		
F-23	23			
F-5P5		5		
G-33	33			
H-10P4	6		4	
H-29P7	22	7		
H-36P2	34		2	
H-54P2	52	2		
H-5P5			5	
H-66	66			
J-17P4	13	4		
J-25P2	23	2		
J-33	33			
J-7P7		7		
K-27P4	23	4		
K-35P2	33	2		
K-43	43			
K-9P9		9		
L-6P6			6	
L-78	78			
M-102	102			

Table II: Capacitor Array Code / Capacitance Range

Class	Pi - Circuit (pF)	C - Circuit (pF)
X*†	160,000 - 240,000	80,000 - 120,000
Y*	80,000 - 120,000	40,000 - 60,000
Z*	60,000 - 90,000	30,000 - 45,000
A	38,000 - 56,000	19,000 - 28,000
B	32,000 - 45,000	16,000 - 22,500
C	18,000 - 33,000	9,000 - 16,500
D	8,000 - 12,000	4,000 - 6,000
E	3,300 - 5,000	1,650 - 2,500
F	800 - 1,300	400 - 650
G	400 - 600	200 - 300
J	70-120	35-60

* Filter Classes X, Y and Z are 250 VDC. All others are 500 VDC
 † Class X filters not available for insert arrangements with 3 or more rows of contacts



Table III: Hardware Option

N No Mating Hardware		Connector supplied with blind tapped holes. .150" (3.8 mm) minimum depth. Shell size M has #8-32 UNC-2B thread. Shell sizes H and L have #6-32 UNC-2B thread. All other sizes have #4-40 UNC-2B thread.
P Jackposts		Connector is supplied with non-removable stainless steel jackposts. Shell size M has 6-32-UNC thread. Shell sizes H and L have #4-40 UNC-2B thread. All other sizes have #2-56 UNC-2B thread.

Dimensions in inches (millimeters) and are subject to change without notice.



240-790-044S SHELL SIZE A, B, C, D, E, F, J AND K DIMENSIONS

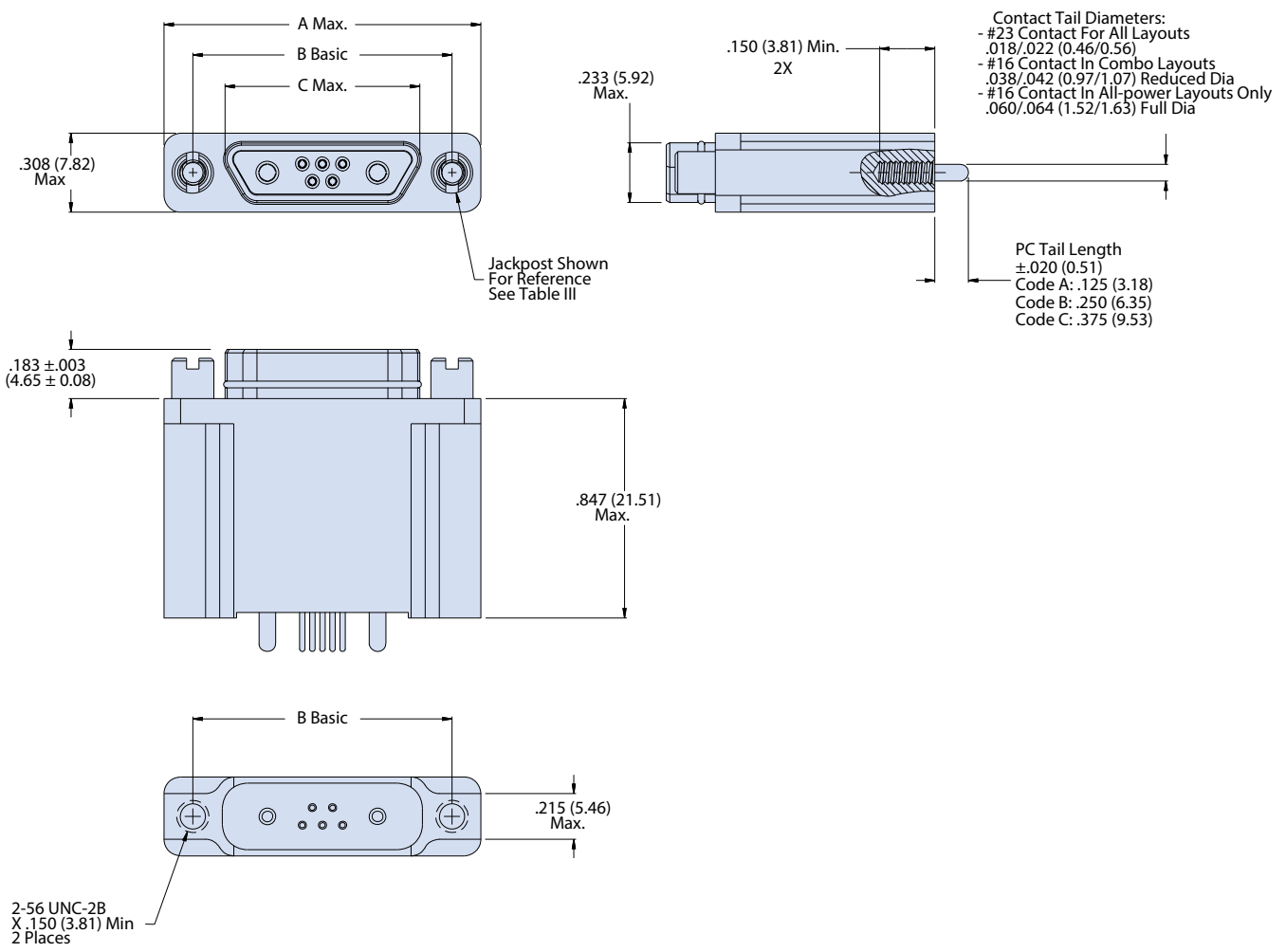

Shell Sizes A,B,C,D,E,F,J,K

790-044S Dimensions for Size A-F, J and K						
Shell Size	A Max.		B Basic		C Max	
	In.	mm.	In.	mm.	In.	mm.
A	.785	19.94	.565	14.35	.335	8.51
B	.935	23.75	.715	18.16	.485	12.32
C	1.085	27.56	.865	21.97	.635	16.13
D	1.185	30.10	.965	24.51	.735	18.67
E	1.335	33.91	1.115	28.32	.885	22.48
F	1.485	37.72	1.265	32.13	1.035	26.29
J	1.845	46.86	1.615	41.02	1.390	35.31
K	2.240	56.90	2.015	51.18	1.795	45.59

Dimensions in inches (millimeters) and are subject to change without notice.

240-790-044
 Series 79 Filtered Plug
 Vertical PCB Mount with Straight PC Tails



Series 79
 Micro-Crimp

240-790-044S SHELL SIZE G DIMENSIONS

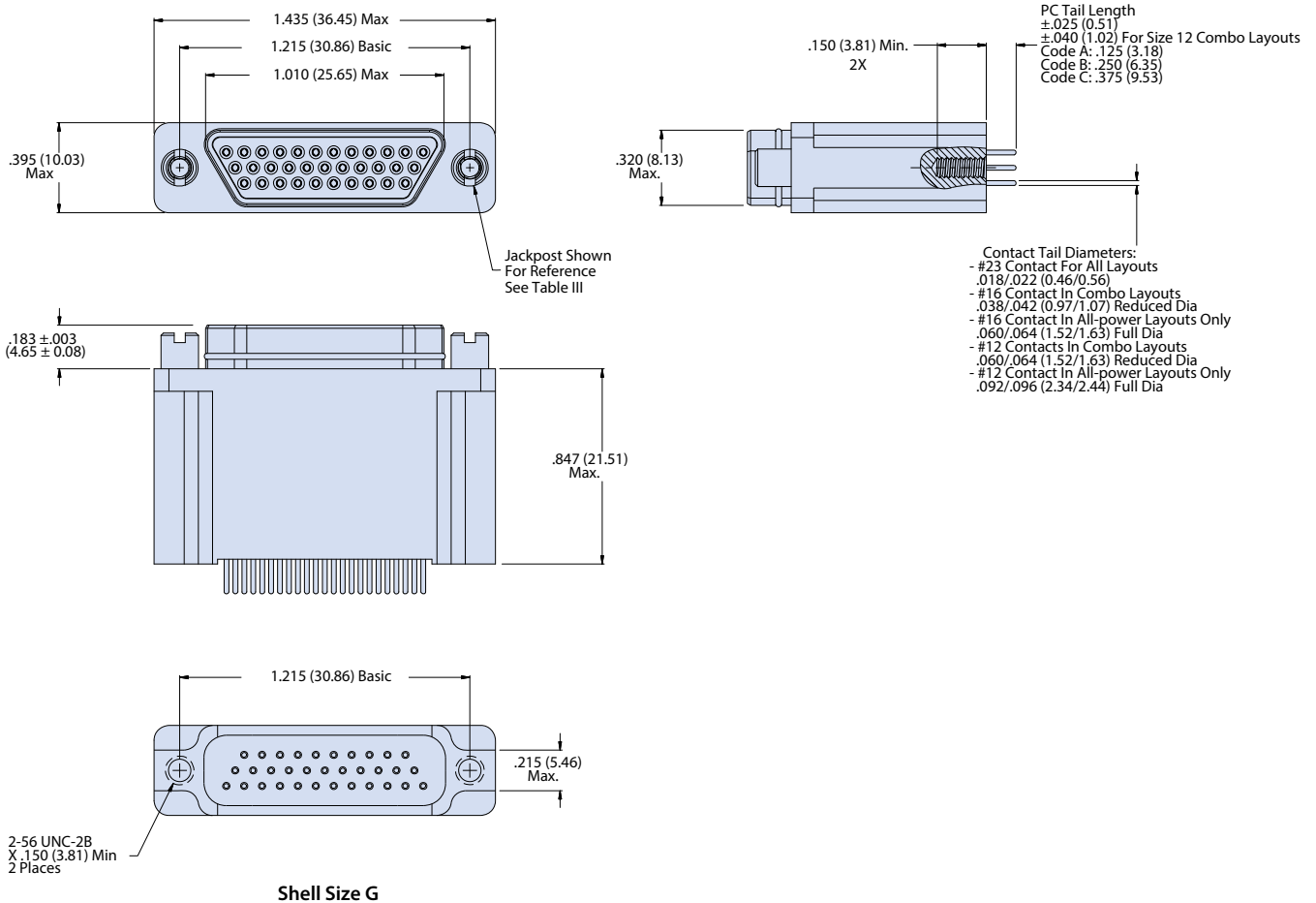

Dimensions in inches (millimeters) and are subject to change without notice.

© 2013 Glenair, Inc.

U.S. CAGE Code 06324

Printed in U.S.A.



240-790-044S SHELL SIZE H AND L DIMENSIONS

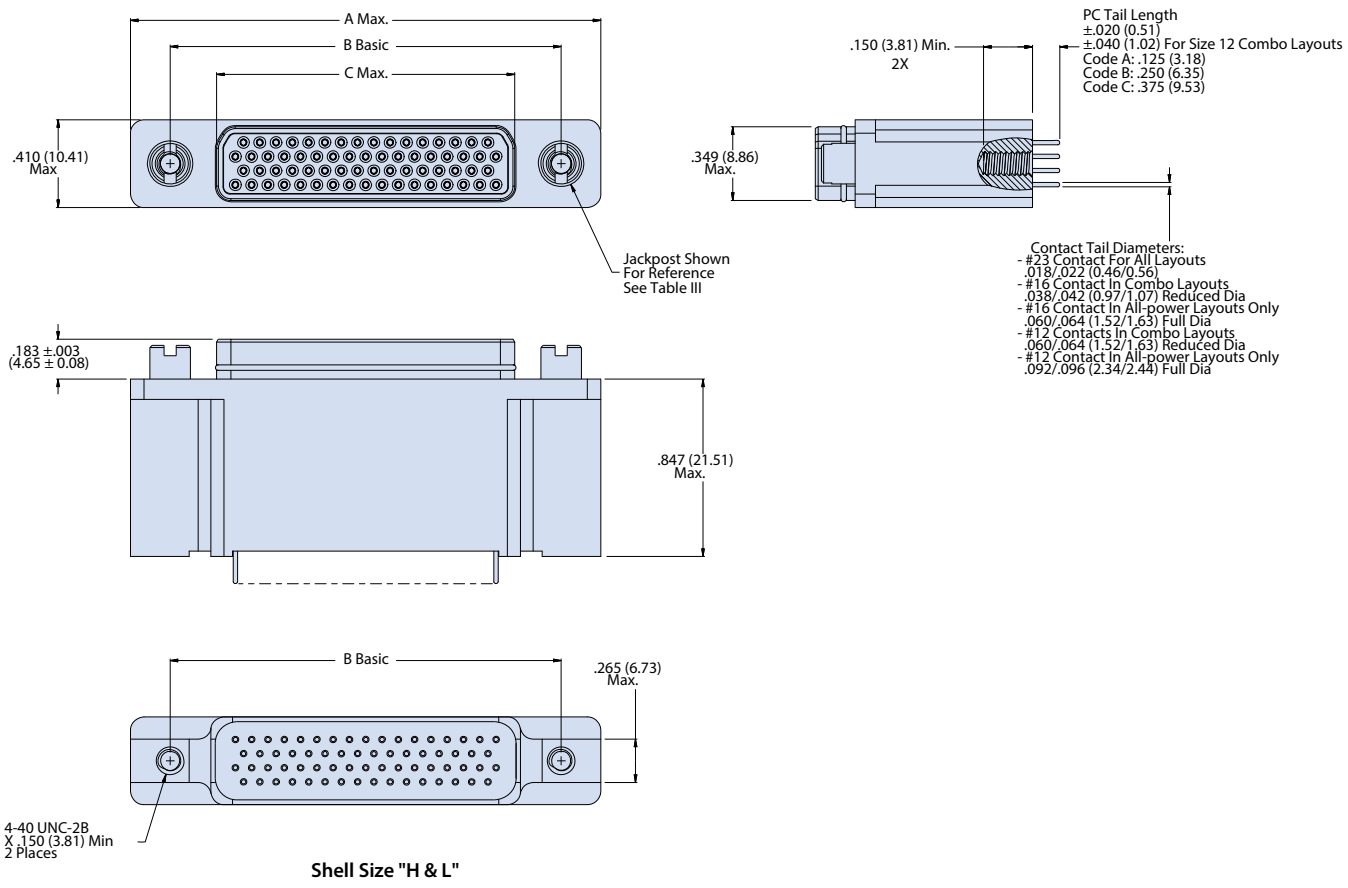

790-44S Size H & L Dimensions						
Shell Size	A Max		B Basic		C Max	
	In.	mm.	In.	mm.	In.	mm.
H	2.175	55.25	1.800	45.72	1.385	35.18
L	2.420	61.47	2.036	51.71	1.623	41.22

Dimensions in inches (millimeters) and are subject to change without notice.

240-790-044
 Series 79 Filtered Plug
 Vertical PCB Mount with Straight PC Tails



240-790-044S SHELL SIZE M DIMENSIONS

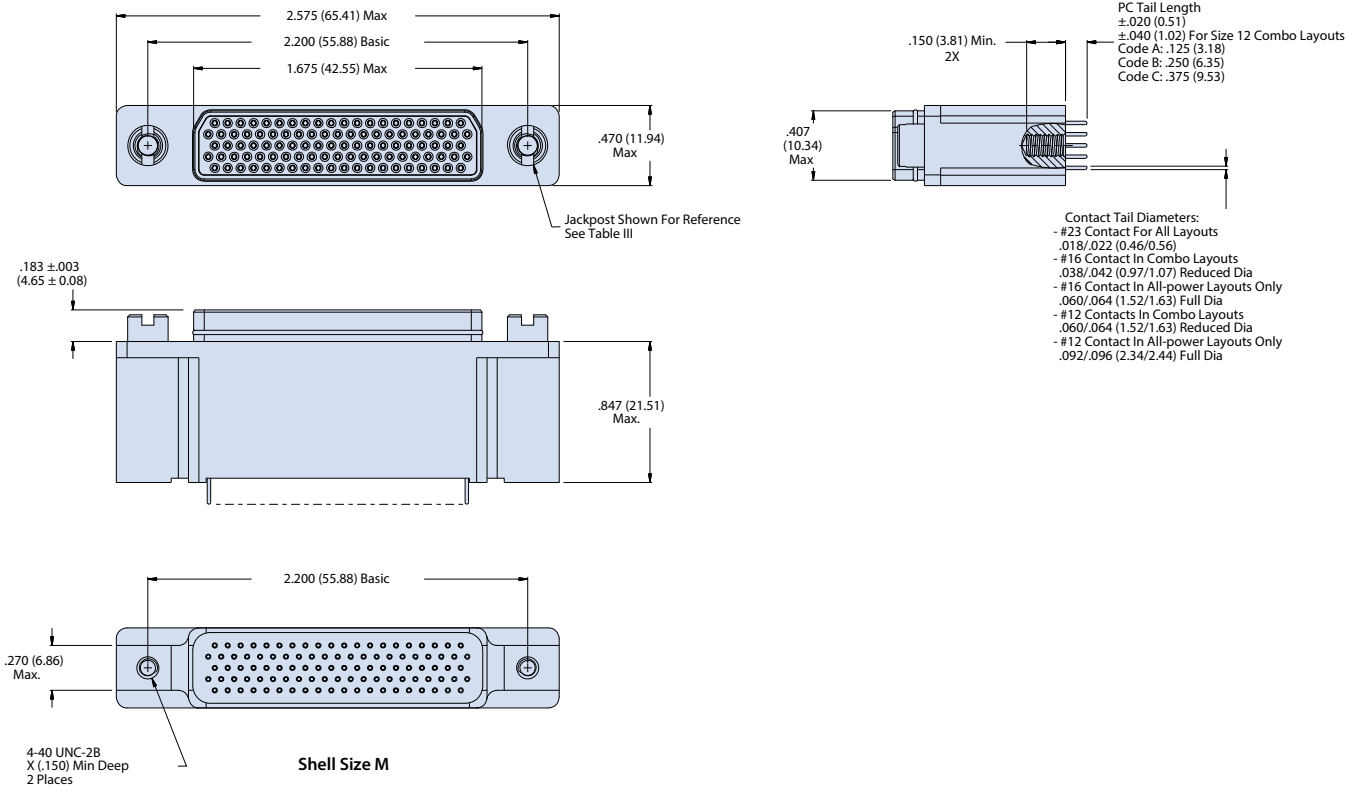

Dimensions in inches (millimeters) and are subject to change without notice.

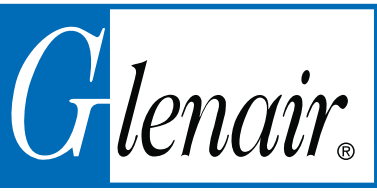

240-790-028P and 240-790-043P Straight PCB Connectors Receptacle PCB Hole Patterns

240-790-028P AND 240-790-043P RECEPTACLE PCB HOLE PATTERNS

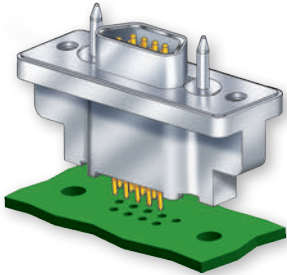

This section contains printed circuit board footprints for vertical mounted Series 79 receptacles. The contact identification numbers are shown for the connector mounting side of the PC board. Contact tails are gold over nickel plated.

Contact Size	Layouts	PC Tail Diameter	
		In.	mm.
#23	All	.018 / .022	.46 / .56
#16	Combo	.038 / .042	.97 / 1.07
	Power	.060 / .064	1.52 / 1.63
#12	Combo	.060 / .064	1.52 / 1.63
	Power	.092 / .096	2.34 / 2.44

240-790-028P and 240-790-043P Printed Circuit Board Patterns	
Insert Arrangement	Component Mounting Side of PCB
A-5	
B-2P2	
B-9	
C-13	

Dimensions in inches (millimeters) and are subject to change without notice.

240-790-028P and 240-790-043P
Straight PCB Connectors
Receptacle PCB Hole Patterns



240-790-028P and 240-790-043P Printed Circuit Board Patterns	
Insert Arrangement	Component Mounting Side of PCB
D-15	
D-3P3	
D-7P2	
E-11P2	
E-19	

Dimensions in inches (millimeters) and are subject to change without notice.



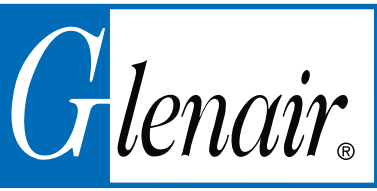

240-790-028P and 240-790-043P Straight PCB Connectors Receptacle PCB Hole Patterns

240-790-028P and 240-790-043P Printed Circuit Board Patterns	
Insert Arrangement	Component Mounting Side of PCB
E-7P3	
F-15P2	
F-23	
F-5P5	
G-33	

Dimensions in inches (millimeters) and are subject to change without notice.

240-790-028P and 240-790-043P
Straight PCB Connectors
Receptacle PCB Hole Patterns



240-790-028P and 240-790-043P Printed Circuit Board Patterns	
Insert Arrangement	Component Mounting Side of PCB
H-10P4	<p>Dimensions: .125 ± .003 (3.18 ± 0.08) 2x, .428 (10.87), .0375 (0.95) TYP, .075 (1.91) TYP, 1.800 (45.72), .236 (5.99), .472 (11.99), .944 (23.98), .0325 (0.83) TYP, .065 (1.65). Contact locations: (HOLE TO ACCEPT #23 CONTACT 6x), (HOLE TO ACCEPT #12 CONTACT 4x). Features: A1, A2, A3, A4, A5, A6, A7, A8, A9, A10, A11, A12, A13, A14, A15, A16, A17, A18, A19, A20, A21, A22, A23, A24, A25, A26, A27, A28, A29, A30, A31, A32, A33, A34, A35, A36, A37, A38, A39, A40, A41, A42, A43, A44, A45, A46, A47, A48, A49, A50, A51, A52, A53, A54, A55, A56, A57, A58, A59, A60, A61, A62, A63, A64, A65, A66, A67, A68, A69, A70, A71, A72, A73, A74, A75, A76, A77, A78, A79, A80, A81, A82, A83, A84, A85, A86, A87, A88, A89, A90, A91, A92, A93, A94, A95, A96, A97, A98, A99, A100.</p>
H-29P7	<p>Dimensions: .125 ± .003 (3.18 ± 0.08) 2x, .290 (7.37), .050 (1.27) TYP, .175 (4.45) TYP, .075 (1.91), 1.800 (45.72), .375 (9.53), .175 (4.45) 6x, .100 (2.54) TYP, .043 (1.09) TYP, .100 (2.54), .057 (1.45). Contact locations: (HOLE TO ACCEPT #23 CONTACT 22x), (HOLE TO ACCEPT #16 CONTACT 7x). Features: A1, A2, A3, A4, A5, A6, A7, A8, A9, A10, A11, A12, A13, A14, A15, A16, A17, A18, A19, A20, A21, A22, A23, A24, A25, A26, A27, A28, A29, A30, A31, A32, A33, A34, A35, A36, A37, A38, A39, A40, A41, A42, A43, A44, A45, A46, A47, A48, A49, A50, A51, A52, A53, A54, A55, A56, A57, A58, A59, A60, A61, A62, A63, A64, A65, A66, A67, A68, A69, A70, A71, A72, A73, A74, A75, A76, A77, A78, A79, A80, A81, A82, A83, A84, A85, A86, A87, A88, A89, A90, A91, A92, A93, A94, A95, A96, A97, A98, A99, A100.</p>
H-36P2	<p>Dimensions: .125 ± .003 (3.18 ± 0.08) 2x, .428 (10.87), .0375 (0.95) TYP, .075 (1.91) TYP, 1.800 (45.72), .1725 (4.38), .944 (23.98), .0325 (0.83) TYP, .065 (1.65) TYP. Contact locations: (HOLE TO ACCEPT #23 CONTACT 34x), (HOLE TO ACCEPT #12 CONTACT 2x). Features: A1, A2, A3, A4, A5, A6, A7, A8, A9, A10, A11, A12, A13, A14, A15, A16, A17, A18, A19, A20, A21, A22, A23, A24, A25, A26, A27, A28, A29, A30, A31, A32, A33, A34, A35, A36, A37, A38, A39, A40, A41, A42, A43, A44, A45, A46, A47, A48, A49, A50, A51, A52, A53, A54, A55, A56, A57, A58, A59, A60, A61, A62, A63, A64, A65, A66, A67, A68, A69, A70, A71, A72, A73, A74, A75, A76, A77, A78, A79, A80, A81, A82, A83, A84, A85, A86, A87, A88, A89, A90, A91, A92, A93, A94, A95, A96, A97, A98, A99, A100.</p>
H-54P2	<p>Dimensions: .125 ± .003 (3.18 ± 0.08) 2x, .320 (8.13), .0375 (0.95) TYP, .075 (1.91) TYP, 1.800 (45.72), .0925 (2.35), .160 (29.46), .0325 (0.83) TYP, .065 (1.65) TYP. Contact locations: (HOLE TO ACCEPT #23 CONTACT 52x), (HOLE TO ACCEPT #16 CONTACT 2x). Features: A1, A2, A3, A4, A5, A6, A7, A8, A9, A10, A11, A12, A13, A14, A15, A16, A17, A18, A19, A20, A21, A22, A23, A24, A25, A26, A27, A28, A29, A30, A31, A32, A33, A34, A35, A36, A37, A38, A39, A40, A41, A42, A43, A44, A45, A46, A47, A48, A49, A50, A51, A52, A53, A54, A55, A56, A57, A58, A59, A60, A61, A62, A63, A64, A65, A66, A67, A68, A69, A70, A71, A72, A73, A74, A75, A76, A77, A78, A79, A80, A81, A82, A83, A84, A85, A86, A87, A88, A89, A90, A91, A92, A93, A94, A95, A96, A97, A98, A99, A100.</p>
H-5P5	<p>Dimensions: .125 ± .003 (3.18 ± 0.08) 2x, .428 (10.87), .236 (5.99) 4x, 1.800 (45.72), .944 (23.98). Contact locations: (HOLE TO ACCEPT #12 CONTACT 5x). Features: A1, A2, A3, A4, A5, A6, A7, A8, A9, A10, A11, A12, A13, A14, A15, A16, A17, A18, A19, A20, A21, A22, A23, A24, A25, A26, A27, A28, A29, A30, A31, A32, A33, A34, A35, A36, A37, A38, A39, A40, A41, A42, A43, A44, A45, A46, A47, A48, A49, A50, A51, A52, A53, A54, A55, A56, A57, A58, A59, A60, A61, A62, A63, A64, A65, A66, A67, A68, A69, A70, A71, A72, A73, A74, A75, A76, A77, A78, A79, A80, A81, A82, A83, A84, A85, A86, A87, A88, A89, A90, A91, A92, A93, A94, A95, A96, A97, A98, A99, A100.</p>

Dimensions in inches (millimeters) and are subject to change without notice.



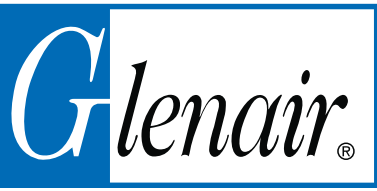

240-790-028P and 240-790-043P Straight PCB Connectors Receptacle PCB Hole Patterns

240-790-028P and 240-790-043P Printed Circuit Board Patterns

Insert Arrangement	Component Mounting Side of PCB
H-66	
J-17P4	
J-25P2	
J-33	
J-7P7	
K-27P4	

Dimensions in inches (millimeters) and are subject to change without notice.

© 2013 Glenair, Inc. U.S. CAGE Code 06324 Printed in U.S.A.

240-790-028P and 240-790-043P
Straight PCB Connectors
Receptacle PCB Hole Patterns



240-790-028P and 240-790-043P Printed Circuit Board Patterns	
Insert Arrangement	Component Mounting Side of PCB
K-35P2	<p>Dimensions: .2575 (6.54), .094 ± .003 (2.39 ± 0.08) 2x, .4075 (10.35), .075 (1.91) TYP, 2.015 (51.18), .0375 (0.95) TYP, 1.500 (38.1), .0325 (0.83) TYP, .065 (1.65) TYP. HOLE TO ACCEPT #16 CONTACT 2x, HOLE TO ACCEPT #23 CONTACT 33x.</p>
K-43	<p>Dimensions: .220 (5.59), .094 ± .003 (2.39 ± 0.08) 2x, .075 (1.91) TYP, 2.015 (51.18), .0375 (0.95) TYP, .065 (1.65) TYP, .0325 (0.83) TYP. HOLE TO ACCEPT #23 CONTACT 43x.</p>
K-9P9	<p>Dimensions: .094 ± .003 (2.39 ± 0.08) 2x, .3075 (7.81), 2.015 (51.18), .175 (4.45). HOLE TO ACCEPT #16 CONTACT 9x.</p>
L-6P6	<p>Dimensions: .125 ± .003 (3.18 ± 0.08) 2x, .428 (10.87), .236 (5.99) 5x, 2.036 (51.71). HOLE TO ACCEPT #12 CONTACT 6x.</p>
L-78	<p>Dimensions: .125 ± .003 (3.18 ± 0.08) 2x, .3055 (7.76), .038 (.97) TYP, .075 (1.91) TYP, 2.036 (51.71), .065 (1.65) TYP, .0325 (.83) TYP. HOLE TO ACCEPT #23 CONTACT 78x.</p>
M-102	<p>Dimensions: .125 ± .003 (3.18 ± 0.08) 2x, .350 (8.89), .038 (.97) TYP, .075 (1.91) TYP, 2.200 (55.88), .065 (1.65) TYP, .0325 (.83) TYP. HOLE TO ACCEPT #23 CONTACT 102x.</p>

Dimensions in inches (millimeters) and are subject to change without notice.



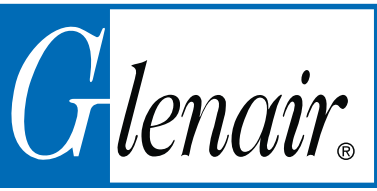

240-790-029S and 240-790-044S Straight PCB Connectors Plug PCB Hole Patterns

240-790-029S AND 240-790-044S PLUGS PCB HOLE PATTERNS

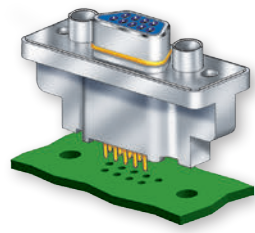

This section contains printed circuit board footprints for vertical mounted Series 79 plugs. The contact identification numbers are shown for the connector mounting side of the PC board. Contact tails are gold over nickel plated.

		PC Tail Diameter	
Contact Size	Layouts	ø Diameter	
		In.	mm.
#23	All	.018 / .022	.46 / .56
#16	Combo	.038 / .042	.97 / 1.07
	Power	.060 / .064	1.52 / 1.63
#12	Combo	.060 / .064	1.52 / 1.63
	Power	.092 / .096	2.34 / 2.44

240-790-029S and 240-790-044S Printed Circuit Board Patterns	
Insert Arr.	Component Mounting Side of PCB
A-5	
B-2P2	
B-9	
C-13	

Dimensions in inches (millimeters) and are subject to change without notice.

240-790-029S and 240-790-044S
Straight PCB Connectors
Plug PCB Hole Patterns



240-790-029S and 240-790-044S Printed Circuit Board Patterns	
Insert Arr.	Component Mounting Side of PCB
D-15	
D-3P3	
D-7P2	
E-11P2	
E-19	

Dimensions in inches (millimeters) and are subject to change without notice.





240-790-029S and 240-790-044S Straight PCB Connectors Plug PCB Hole Patterns

Insert Arr.	240-790-029S and 240-790-044S Printed Circuit Board Patterns
Component Mounting Side of PCB	
E-7P3	
F-15P2	
F-23	
F-5P5	
G-33	

Dimensions in inches (millimeters) and are subject to change without notice.

240-790-029S and 240-790-044S
Straight PCB Connectors
Plug PCB Hole Patterns



Series 79
Micro-Crimp

240-790-029S and 240-790-044S Printed Circuit Board Patterns

Insert Arr.	Component Mounting Side of PCB
H-10P4	<p>Dimensions: .125 ± .003 (3.18 ± 0.08) 2x, .428 (10.87), .0375 (0.95) TYP, .075 (1.91) TYP, 1.800 (45.72), .236 (5.99), .472 (11.99), .944 (23.98), .0325 (0.83) TYP, .065 (1.65), .075 (1.91) TYP, .0325 (0.83) TYP, .065 (1.65). Features: (HOLE TO ACCEPT #23 CONTACT 6x), (HOLE TO ACCEPT #12 CONTACT 4x), $\varnothing .003$ A M.</p>
H-29P7	<p>Dimensions: .125 ± .003 (3.18 ± 0.08) 2x, .290 (7.37), .050 (1.27) TYP, .175 (4.45) TYP, 1.800 (45.72), .375 (9.53), .175 (4.45) 6x, .100 (2.54) TYP, .043 (1.09) TYP, .100 (2.54), .057 (1.45). Features: (HOLE TO ACCEPT #23 CONTACT 22x), (HOLE TO ACCEPT #16 CONTACT 7x), $\varnothing .003$ A M.</p>
H-36P2	<p>Dimensions: .125 ± .003 (3.18 ± 0.08) 2x, .428 (10.87), .0375 (0.95) TYP, .075 (1.91) TYP, 1.800 (45.72), .1725 (4.38), .944 (23.98), .0325 (0.83) TYP, .065 (1.65) TYP. Features: (HOLE TO ACCEPT #23 CONTACT 34x), (HOLE TO ACCEPT #12 CONTACT 2x), $\varnothing .003$ A M.</p>
H-54P2	<p>Dimensions: .125 ± .003 (3.18 ± 0.08) 2x, .320 (8.13), .0375 (0.95) TYP, .075 (1.91) TYP, 1.800 (45.72), .0925 (2.35), 1.160 (29.46), .0325 (0.83) TYP, .065 (1.65) TYP. Features: (HOLE TO ACCEPT #23 CONTACT 52x), (HOLE TO ACCEPT #16 CONTACT 2x), $\varnothing .003$ A M.</p>
H-5P5	<p>Dimensions: .125 ± .003 (3.18 ± 0.08) 2x, .428 (10.87), .236 (5.99) 4x, 1.800 (45.72), .944 (23.98). Features: (HOLE TO ACCEPT #12 CONTACT 5x), $\varnothing .003$ A M.</p>

Dimensions in inches (millimeters) and are subject to change without notice.





240-790-029S and 240-790-044S Straight PCB Connectors Plug PCB Hole Patterns

240-790-029S and 240-790-044S Printed Circuit Board Patterns	
Insert Arr.	Component Mounting Side of PCB
H-66	
J-17P4	
J-25P2	
J-33	
J-7P7	
K-27P4	

Dimensions in inches (millimeters) and are subject to change without notice.

240-790-029S and 240-790-044S
Straight PCB Connectors
Plug PCB Hole Patterns



240-790-029S and 240-790-044S Printed Circuit Board Patterns

Insert Arr.	Component Mounting Side of PCB
K-35P2	
K-43	
K-9P9	
L-6P6	
L-78	
M-102	

Dimensions in inches (millimeters) and are subject to change without notice.





240-790-069P SHELL SIZE A, B, C, D, E, F, J AND K DIMENSIONS

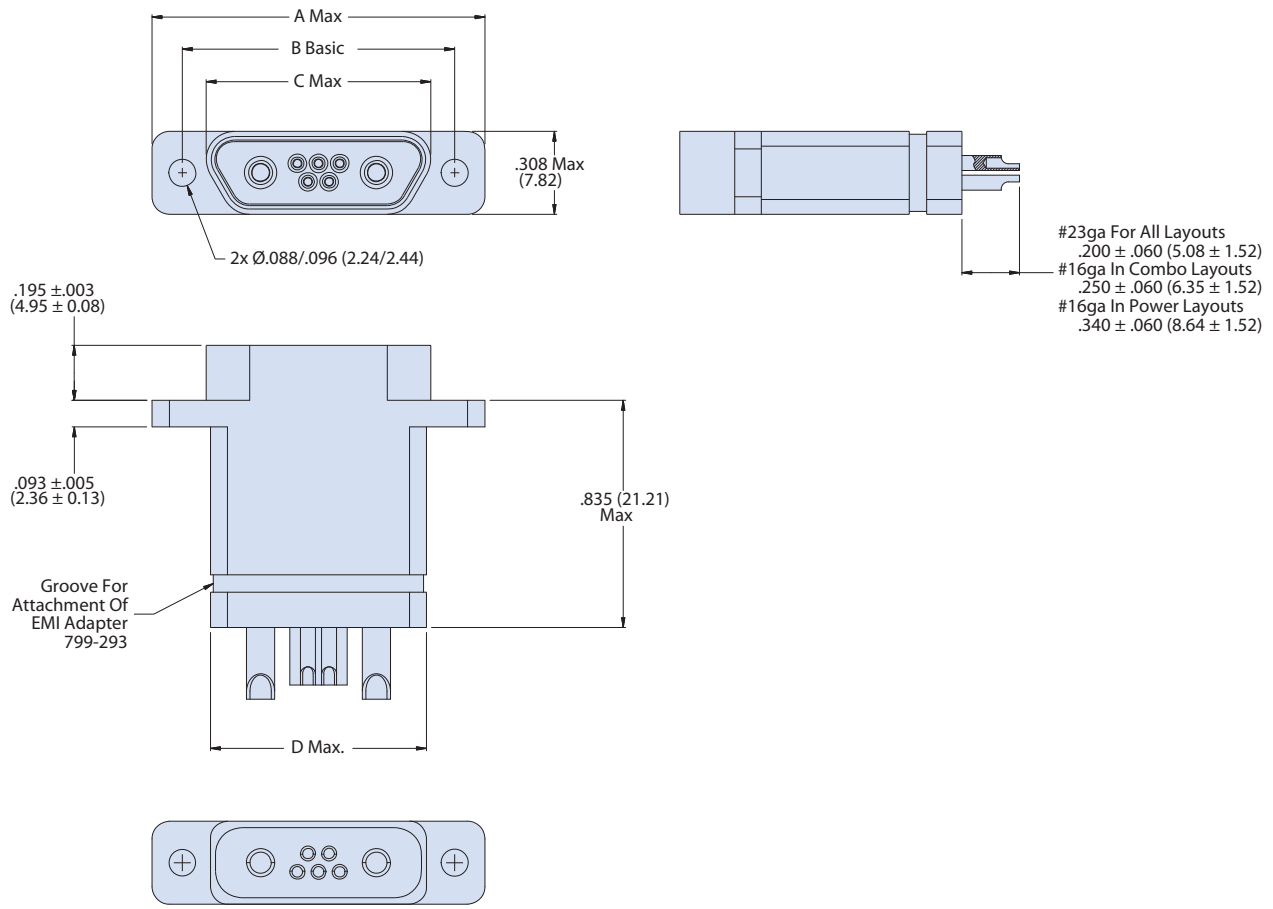

Shell Sizes A,B,C,D,E,F,J,K

790-069P Dimensions for Size A-F, J and K								
Shell Size	A Max.		B Basic		C Max		D Max	
	In.	mm.	In.	mm.	In.	mm.	In.	mm.
A	.785	19.94	.565	14.35	.400	10.16	.390	9.91
B	.935	23.75	.715	18.16	.551	14.00	.540	13.72
C	1.085	27.56	.865	21.97	.701	17.81	.690	17.53
D	1.185	30.10	.965	24.51	.801	20.35	.790	20.07
E	1.335	33.91	1.115	28.32	.951	24.16	.940	23.88
F	1.485	37.72	1.265	32.13	1.101	27.96	1.090	27.69
J	1.845	46.86	1.615	41.02	1.460	37.08	1.450	36.83
K	2.240	56.90	2.015	51.18	1.860	47.24	1.840	46.74

Dimensions in inches (millimeters) and are subject to change without notice.

240-790-069
 Series 79 Filtered Cable Receptacle
 with Solder Cup Termination



Series 79
 Micro-Crimp

240-790-069P SHELL SIZE G DIMENSIONS

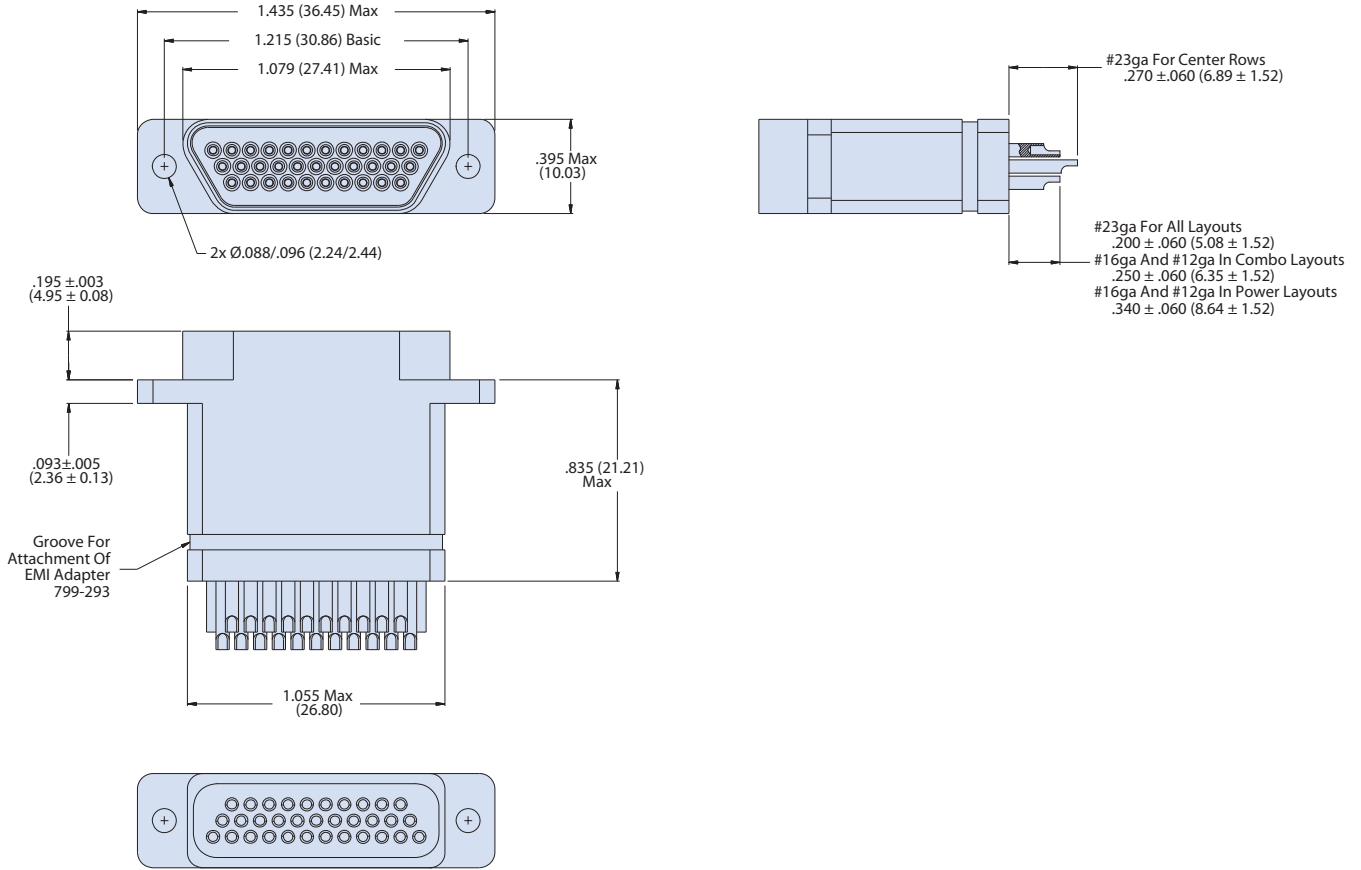

Shell Size G



Dimensions in inches (millimeters) and are subject to change without notice.

© 2013 Glenair, Inc.

U.S. CAGE Code 06324

Printed in U.S.A.

GLENAIR, INC. • 1211 AIR WAY • GLENDALE, CA 91201-2497 • 818-247-6000 • FAX 818-500-9912
 www.glenair.com G-41 E-Mail: sales@glenair.com

Rev. 04.03.24



240-790-069P SHELL SIZE H AND L DIMENSIONS

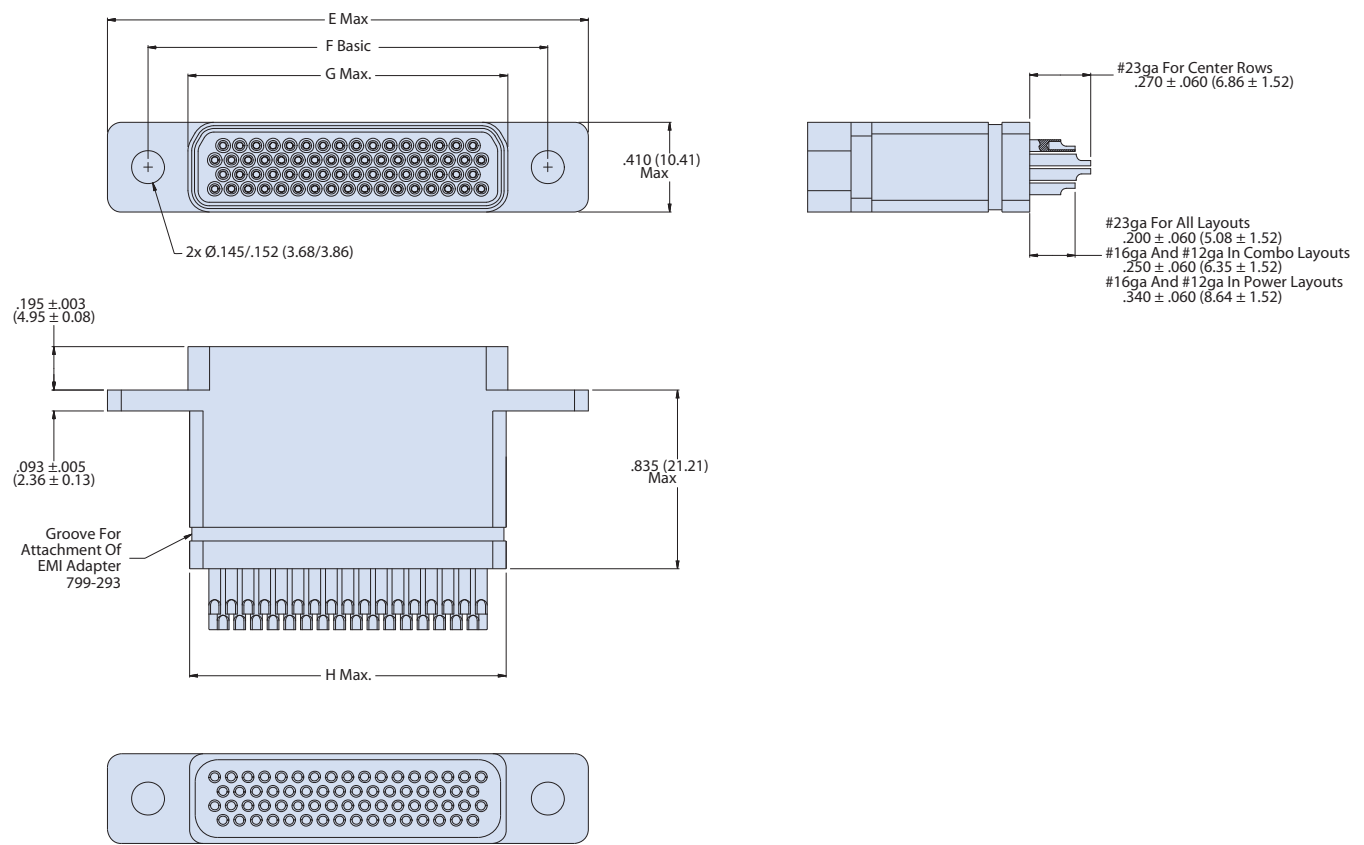

Shell Size H & L

790-069P Size H & L Dimensions								
Shell Size	E Max		F Basic		G Max		H Max	
	In.	mm.	In.	mm.	In.	mm.	In.	mm.
H	2.175	55.25	1.800	45.72	1.385	35.18	1.440	36.58
L	2.420	61.47	2.036	51.71	1.623	41.22	1.675	42.55

Dimensions in inches (millimeters) and are subject to change without notice.

240-790-069
 Series 79 Filtered Cable Receptacle
 with Solder Cup Termination



Series 79
 Micro-Crimp

240-790-069P SHELL SIZE M DIMENSIONS

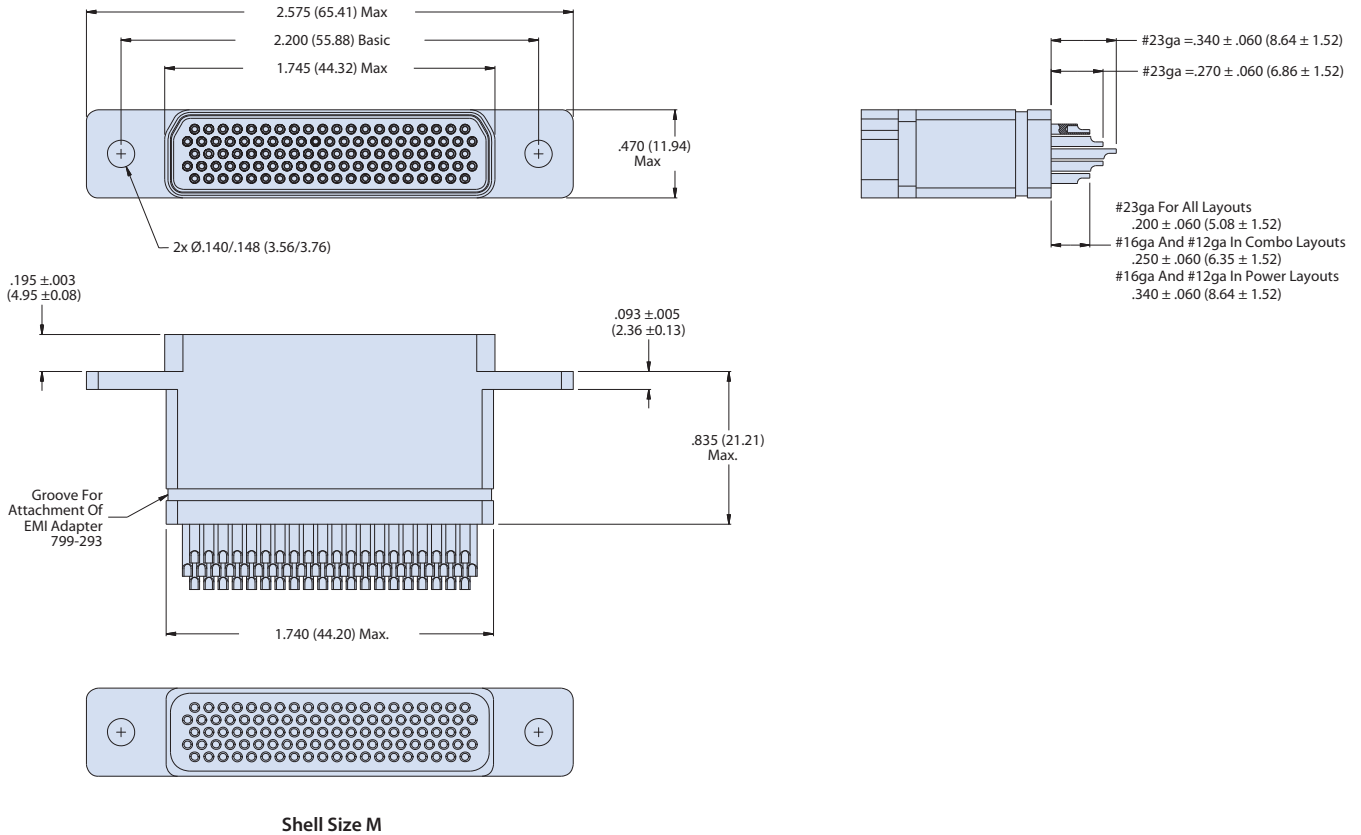

Dimensions in inches (millimeters) and are subject to change without notice.

© 2013 Glenair, Inc.

U.S. CAGE Code 06324

Printed in U.S.A.

GLENAIR, INC. • 1211 AIR WAY • GLENDALE, CA 91201-2497 • 818-247-6000 • FAX 818-500-9912
 www.glenair.com G-43 E-Mail: sales@glenair.com

Rev. 04.03.24



240-790-070S SHELL SIZE A, B, C, D, E, F, J AND K DIMENSIONS

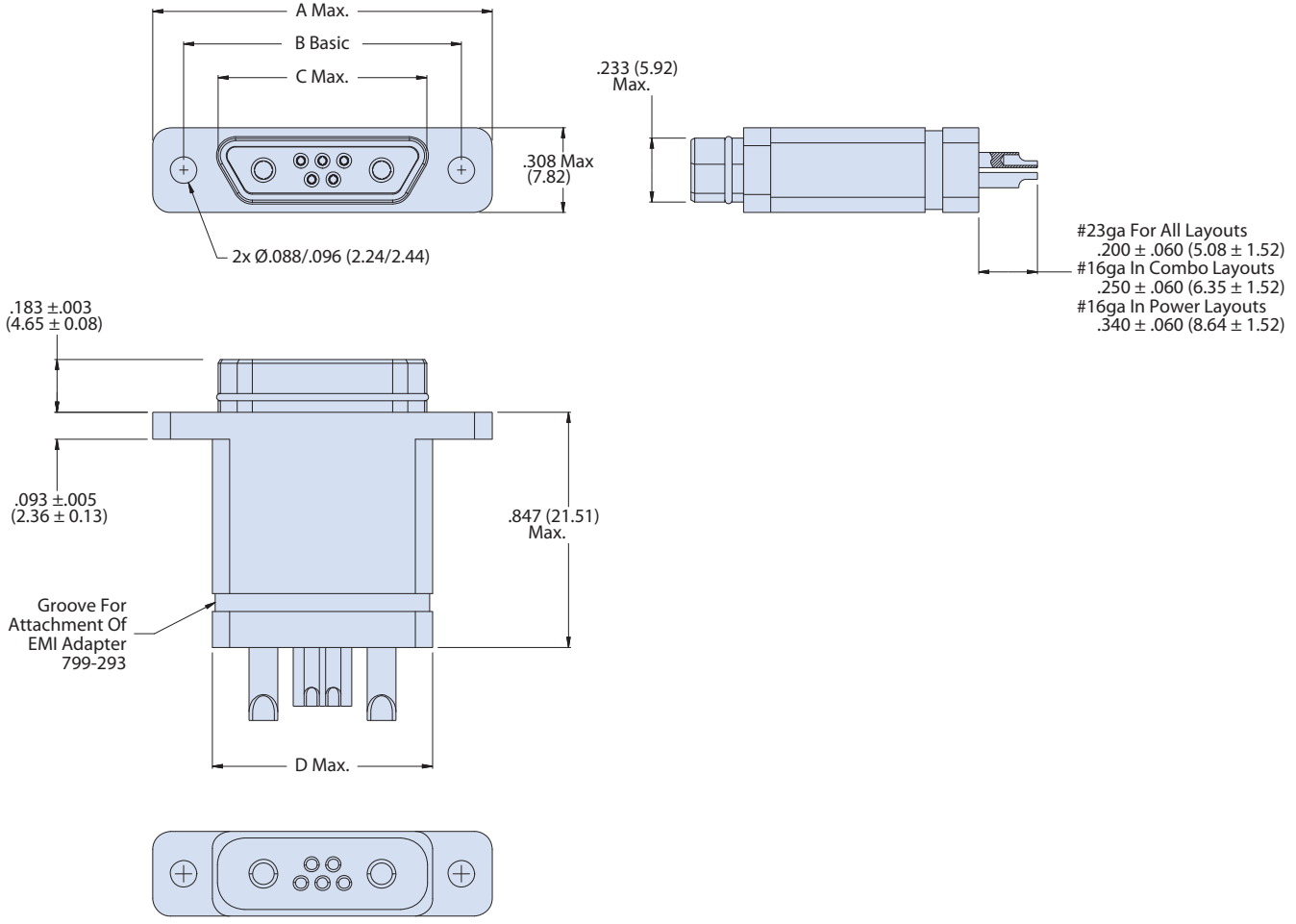

Shell Sizes A,B,C,D,E,F,J,K

790-070S Dimensions for Size A-F, J and K								
Shell Size	A Max.		B Basic		C Max		D Max	
	In.	mm.	In.	mm.	In.	mm.	In.	mm.
A	.785	19.94	.565	14.35	.335	8.51	.390	9.91
B	.935	23.75	.715	18.16	.485	12.32	.540	13.72
C	1.085	27.56	.865	21.97	.635	16.13	.690	17.53
D	1.185	30.10	.965	24.51	.735	18.67	.790	20.07
E	1.335	33.91	1.115	28.32	.885	22.48	.940	23.88
F	1.485	37.72	1.265	32.13	1.035	26.29	1.090	27.69
J	1.845	46.86	1.615	41.02	1.390	35.31	1.450	36.83
K	2.240	56.90	2.015	51.18	1.795	45.59	1.840	46.74

Dimensions in inches (millimeters) and are subject to change without notice.

240-790-070
 Series 79 Filtered Cable Plug
 with Solder Cup Termination



Series 79
 Micro-Crimp

240-790-070S SHELL SIZE G DIMENSIONS

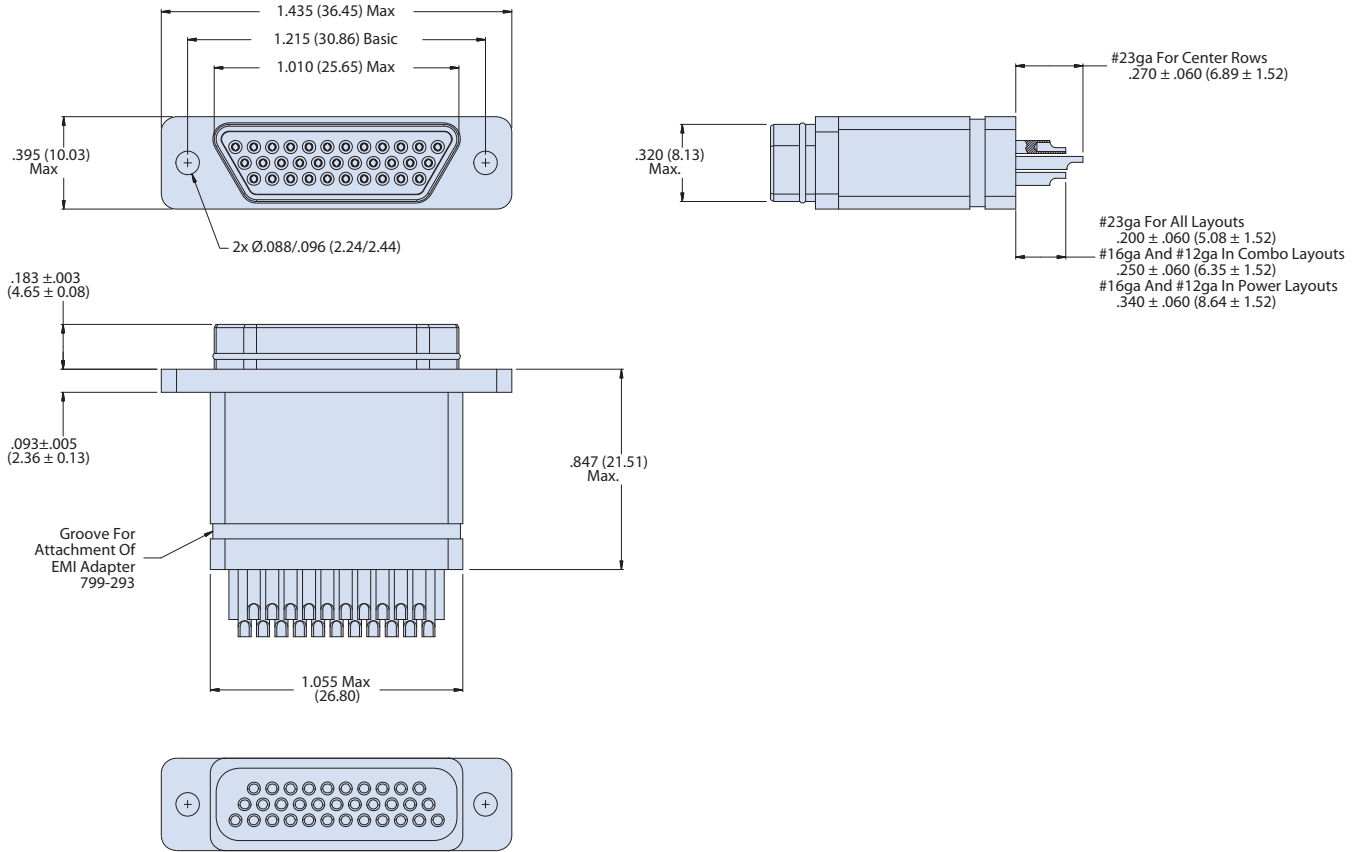

Shell Size G



Dimensions in inches (millimeters) and are subject to change without notice.

© 2013 Glenair, Inc.

U.S. CAGE Code 06324

Printed in U.S.A.

GLENAIR, INC. • 1211 AIR WAY • GLENDALE, CA 91201-2497 • 818-247-6000 • FAX 818-500-9912
 www.glenair.com **G-47** E-Mail: sales@glenair.com

Rev. 04.03.24



240-790-070S SHELL SIZE H AND L DIMENSIONS

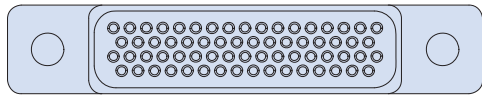
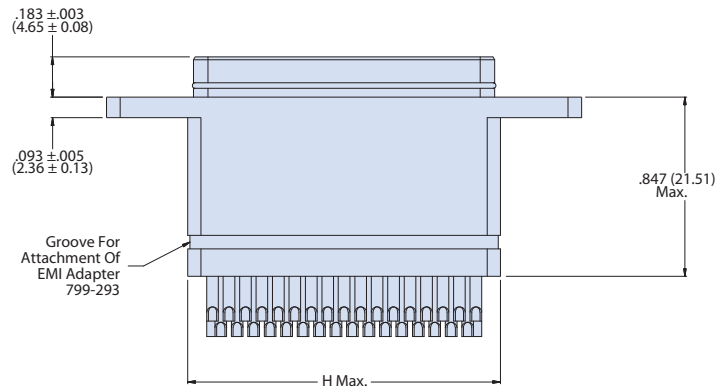
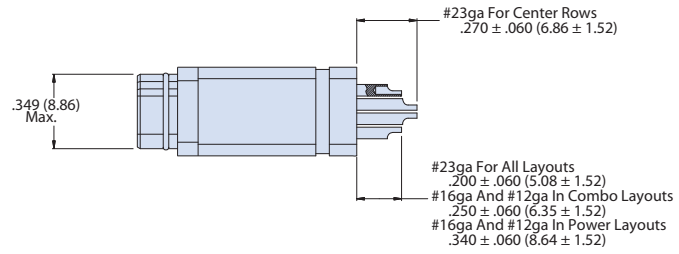
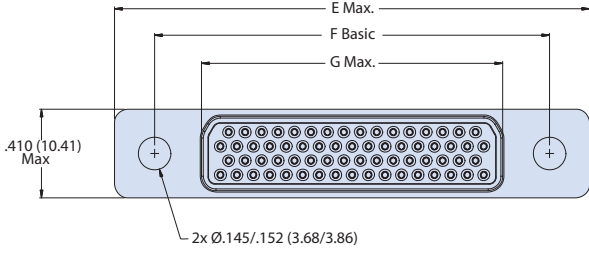

Shell Size H & L

790-070S Size H & L Dimensions								
Shell Size	E Max		F Basic		G Max		H Max	
	In.	mm.	In.	mm.	In.	mm.	In.	mm.
H	2.175	55.25	1.800	45.72	1.385	35.18	1.440	36.58
L	2.420	61.47	2.036	51.71	1.623	41.22	1.675	42.55

Dimensions in inches (millimeters) and are subject to change without notice.

240-790-070
 Series 79 Filtered Cable Plug
 with Solder Cup Termination



240-790-070S SHELL SIZE M DIMENSIONS

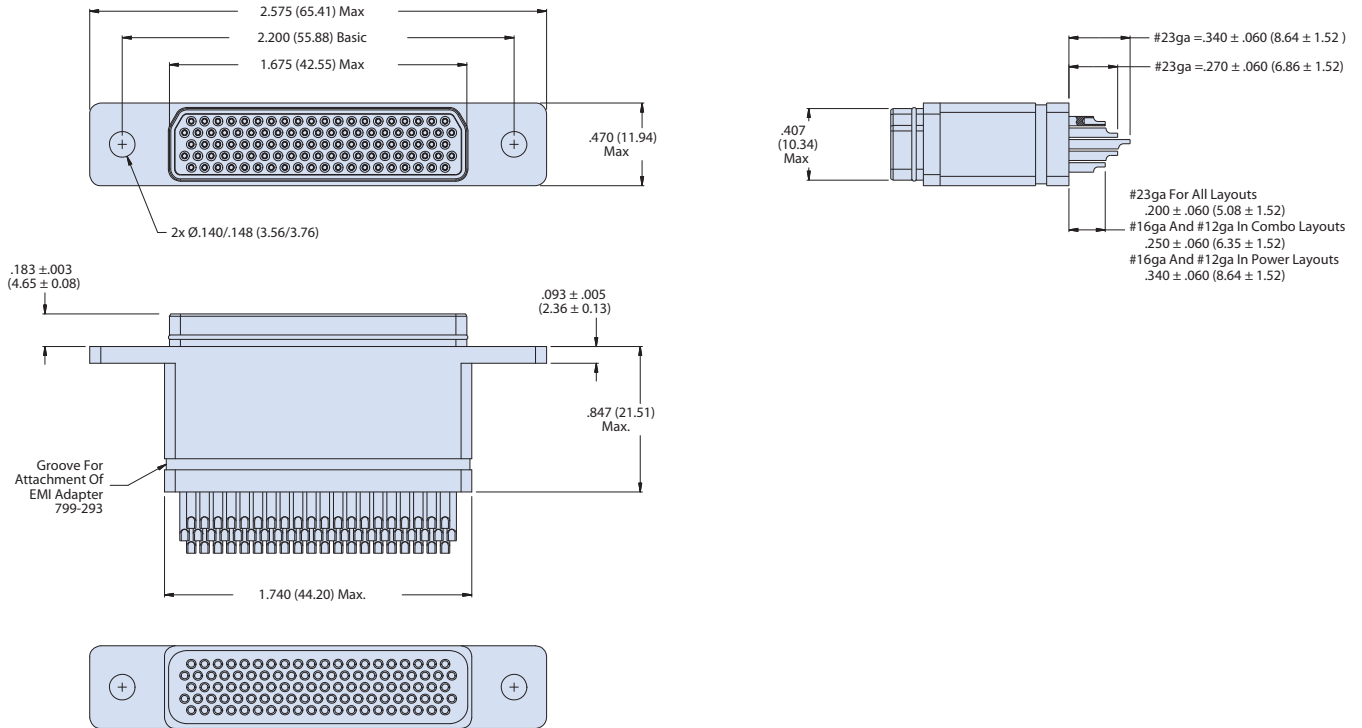

Shell Size M



Dimensions in inches (millimeters) and are subject to change without notice.



240-790-071
Series 79 Filtered Receptacle
Rear Panel Mount with Solder Cup Termination

How To Order Filter Series 79 Connectors	
Sample Part Number	240-790-071 P H-66 ME P D P
Series	240-790-071
Contact Type	P - Pin Contacts
Insert Arrangement	(See Table I)
Shell Material/Finish	Aluminum Shell ME - Electroless Nickel MT - Nickel-PTFE E - Chem Film Z2 - Gold UC - Zinc Cobalt with Black Chromate J - Cadmium with Yellow Chromate NF - Cad/O.D. over Electroless Nickel
Filter Type	C - C Filter P - Pi Filter
Filter Class	X, Y, Z, A, B, C, D, E, F, G, J (See Table II)
Mating Hardware Options	P - Jackposts G - Male Guide Pins S - Female Guide Sockets N - No Mating Hardware (See Table)

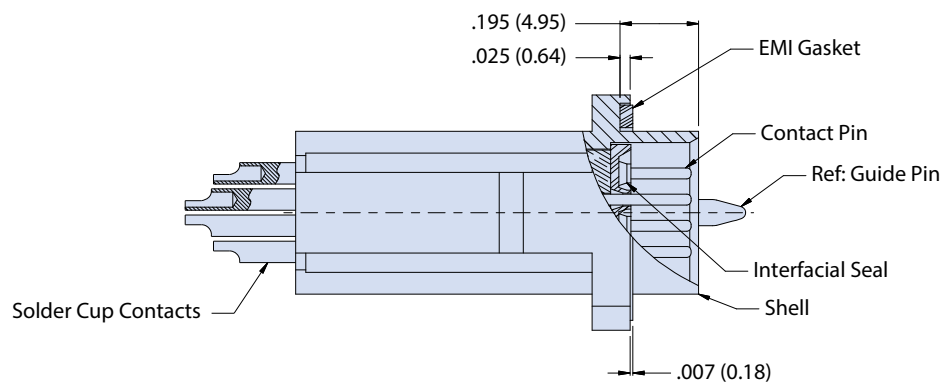
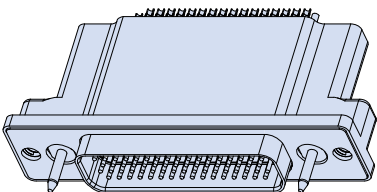

Notes

- Assembly to be identified with Glenair's name, part number, and date code, space permitting
- EMI Filtered receptacle connector designed to meet requirements of MIL-STD-2120 and Glenair Series 79 specifications. Unless otherwise specified herein, refer to Glenair specification 799-008 for additional performance characteristics.
- All contacts to have identical filter value. Other filter arrangements available, contact factory
- Dielectric Withstanding Voltage: 500 VDC (Filter Class X, Y, Z are 250 VDC)
- Insulation Resistance:
5,000 MEGOHMS min @ 200VDC for Class A, B, C, D, E, F, G & J.
1,000 MEGOHMS @ 83VDC for classes, X, Y, & Z

- Current Carrying Capacity
23 Gage - 5 Amps max. for all layouts
16 Gage - 7.5 Amps max. for combo layouts / 13 Amps max. for all-power layouts
12 Gage - 13 Amps max. for combo layouts / 23 Amps max. for all-power layouts
- Other filter styles (C-L, L-C, Unbalanced Pi, Multi-Stage, Multi-Value) are available. Please consult factory with your requirements.

Materials/Finishes:

Insulators - High Grade Rigid Dielectric / N.A.
Interfacial Seal - Fluorosilicone Elastomer / N.A.
Contacts - Copper Alloy / 50 microinches Gold over Nickel
Mating Hardware - 300 Series Stainless Steel / Passivated
EMI Gasket - Silver-Filled Fluorosilicone, CHO-SEAL 1287

Dimensions in inches (millimeters) and are subject to change without notice.

240-790-071
Series 79 Filtered Receptacle
 Rear Panel Mount with Solder Cup Termination



Table I: Contact Arrangements

Layout	Contact Quantity			Face View
	#23	#16	#12	
A-5	5			
B-2P2		2		
B-9	9			
C-13	13			
D-15	15			
D-3P3		3		
D-7P2	5	2		
E-11P2	9	2		
E-19	19			
E-7P3	4	3		
F-15P2	13	2		
F-23	23			
F-5P5		5		
G-33	33			
H-10P4	6		4	
H-29P7	22	7		
H-36P2	34		2	
H-54P2	52	2		
H-5P5			5	
H-66	66			
J-17P4	13	4		
J-25P2	23	2		
J-33	33			
J-7P7		7		
K-27P4	23	4		
K-35P2	33	2		
K-43	43			
K-9P9		9		
L-6P6			6	
L-78	78			
M-102	102			

Table II: Capacitor Array Code / Capacitance Range

Class	Pi - Circuit (pF)	C - Circuit (pF)
X*†	160,000 - 240,000	80,000 - 120,000
Y*	80,000 - 120,000	40,000 - 60,000
Z*	60,000 - 90,000	30,000 - 45,000
A	38,000 - 56,000	19,000 - 28,000
B	32,000 - 45,000	16,000 - 22,500
C	18,000 - 33,000	9,000 - 16,500
D	8,000 - 12,000	4,000 - 6,000
E	3,300 - 5,000	1,650 - 2,500
F	800 - 1,300	400 - 650
G	400 - 600	200 - 300
J	70-120	35-60

* Filter Classes X, Y and Z are 250 VDC.
 All others are 500 VDC
 † Class X filters not available for insert arrangements with 3 or more rows of contacts

Blind mate

SHELL SIZES A, B, C, D, E, F, G, J, K

± .030 (0.76) Allowable misalignment from centerline

SHELL SIZES H, L

± .040 (1.02) Allowable misalignment from centerline

SHELL SIZE M

± .050 (1.27) Allowable misalignment from centerline



Table III: Hardware Option

N No Mating Hardware		Connector supplied with blind tapped holes. .150" (3.8 mm) minimum depth. Shell size M has #8-32 UNC-2B thread. Shell sizes H and L have #6-32 UNC-2B thread. All other sizes have #4-40 UNC-2B thread.
P Jackposts		Connector is supplied with non-removable stainless steel jackposts. Shell size M has 6-32-UNC thread. Shell sizes H and L have #4-40 UNC-2B thread. All other sizes have #2-56 UNC-2B thread.
G Guide Pins		Connector is supplied with stainless steel non-removable guide pins for blind mate applications. Mates with type "S" guide sockets on corresponding plug connector.
S Guide Sockets		Connector is supplied with stainless steel non-removable bushings for blind mate applications. Mates with type "G" guide pins on corresponding plug connector.

Dimensions in inches (millimeters) and are subject to change without notice.



240-790-071P SHELL SIZE A, B, C, D, E, F, J AND K DIMENSIONS

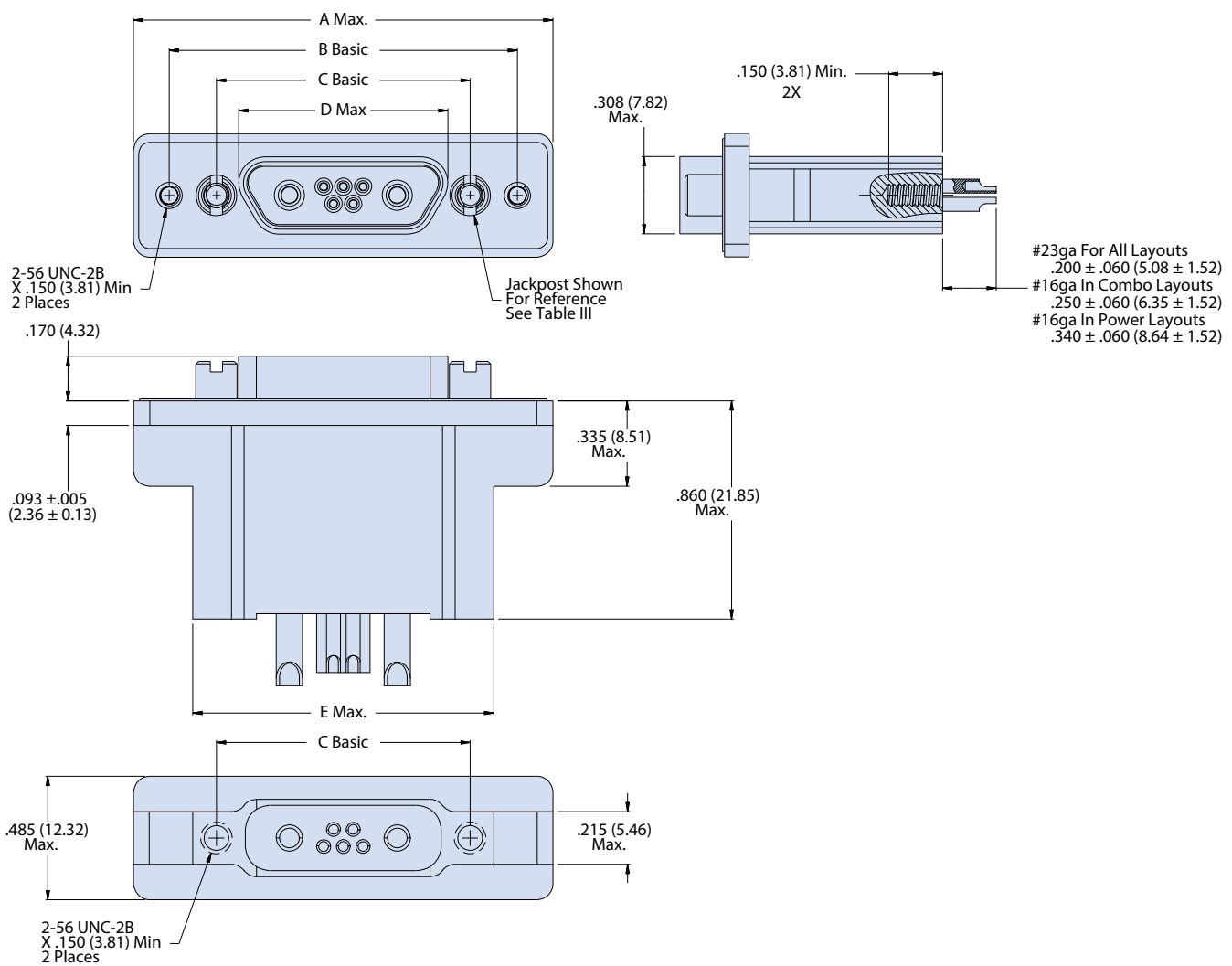

Shell Sizes A,B,C,D,E,F,J,K

790-071P Dimensions for Size A-F, J and K										
Shell Size	A Max.		B Basic		C Basic		D Max		E Max	
	In.	mm.	In.	mm.	In.	mm.	In.	mm.	In.	mm.
A	1.211	30.76	.925	23.50	.565	14.35	.401	10.19	.760	19.30
B	1.361	34.57	1.075	27.31	.715	18.16	.551	14.00	.910	23.11
C	1.511	38.38	1.225	31.12	.865	21.97	.701	17.81	1.060	26.92
D	1.611	40.92	1.325	33.66	.965	24.51	.801	20.35	1.160	29.46
E	1.761	44.73	1.475	37.47	1.115	28.32	.951	24.16	1.310	33.27
F	1.911	48.54	1.625	41.28	1.265	32.13	1.101	27.96	1.460	37.08
J	2.261	57.43	1.975	50.17	1.615	41.02	1.460	37.08	1.810	45.97
K	2.661	67.59	2.375	60.33	2.015	51.18	1.860	47.24	2.210	56.13

Dimensions in inches (millimeters) and are subject to change without notice.

240-790-071
 Series 79 Filtered Receptacle
 Rear Panel Mount with Solder Cup Termination



Series 79
 Micro-Crimp

240-790-071P SHELL SIZE G DIMENSIONS

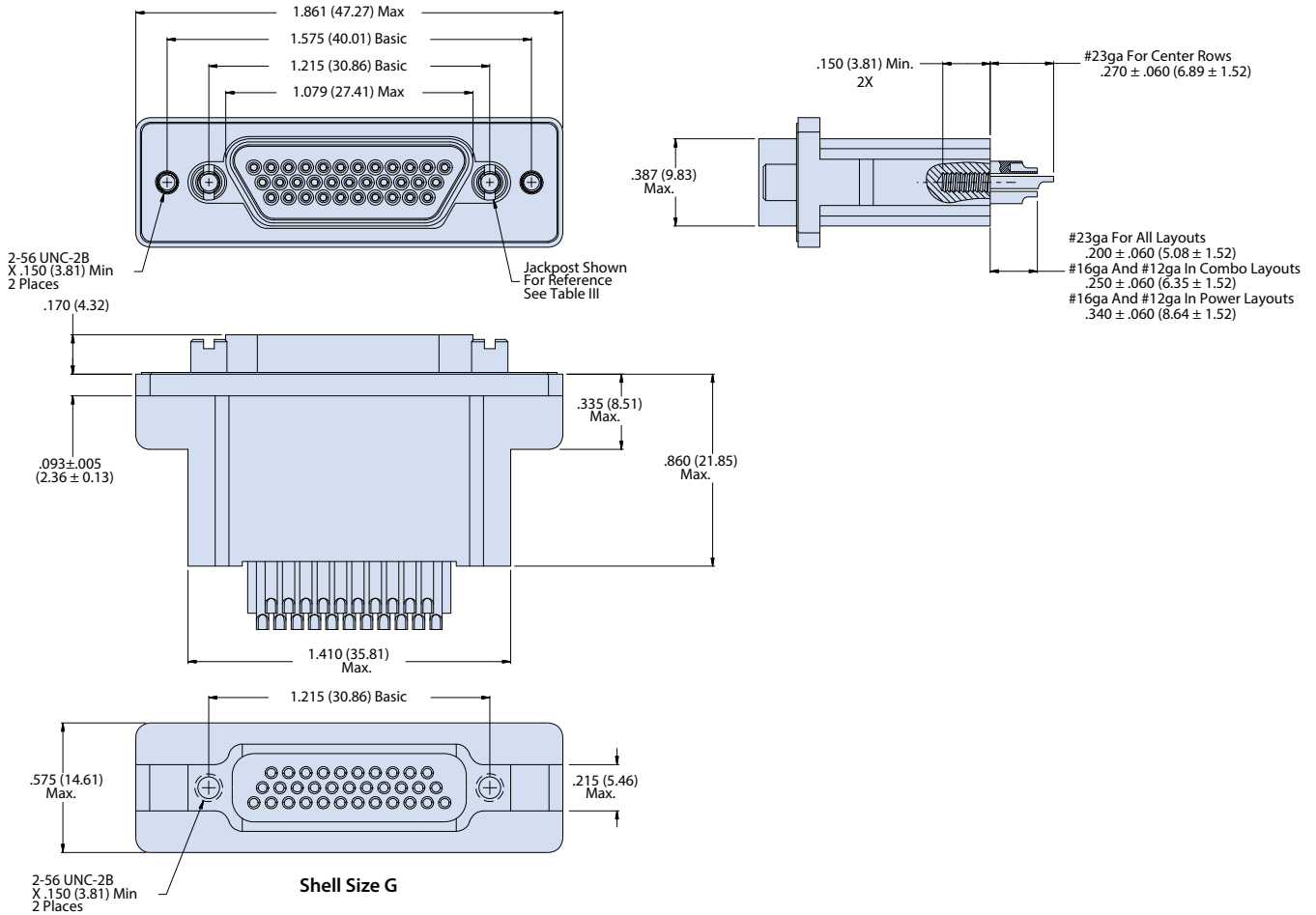

Dimensions in inches (millimeters) and are subject to change without notice.

© 2013 Glenair, Inc.

U.S. CAGE Code 06324

Printed in U.S.A.



240-790-071P SHELL SIZE H AND L DIMENSIONS

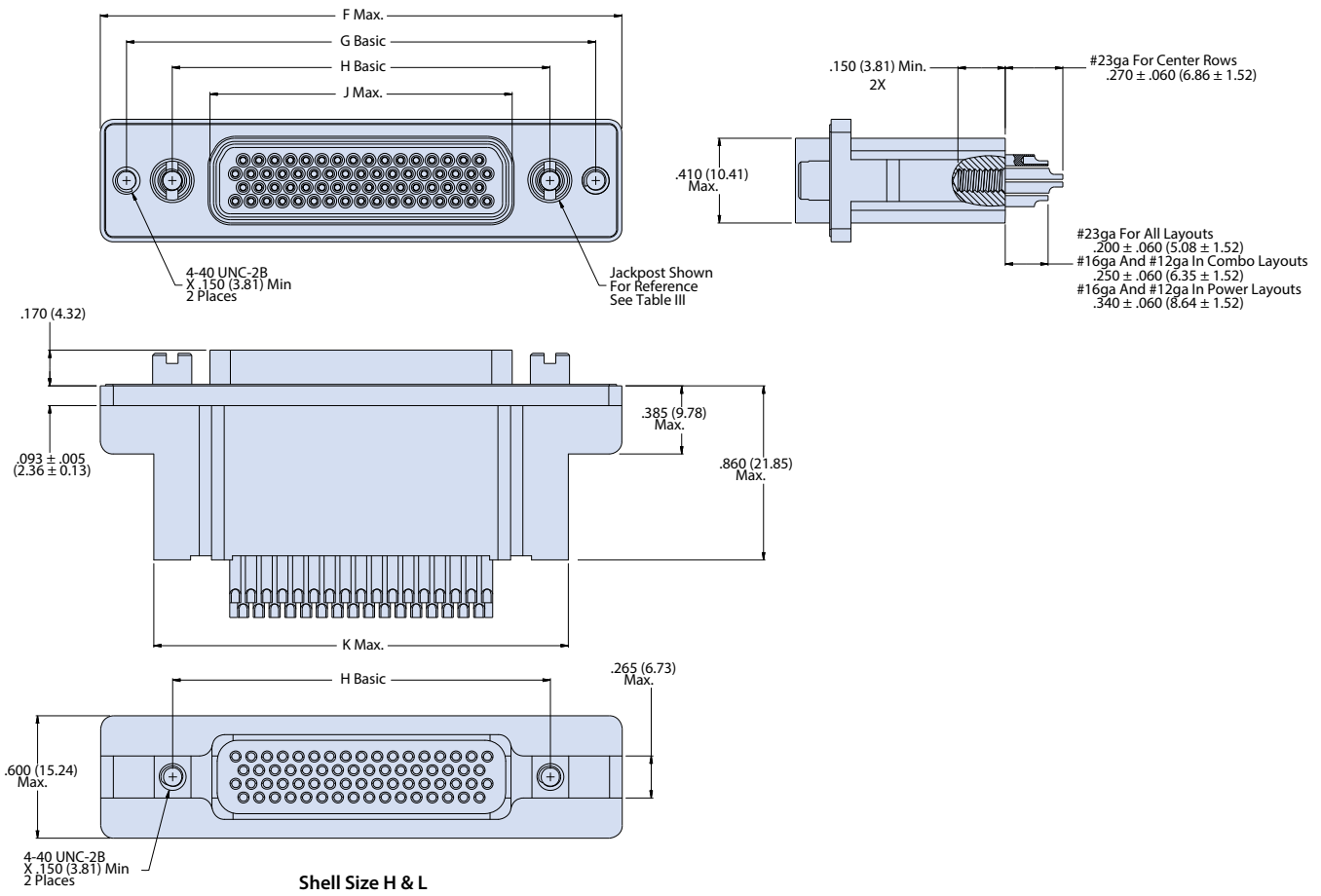

Shell Size H & L

790-071P Size H & L Dimensions										
Shell Size	F Max		G Basic		H Basic		J Max		K Max	
	In.	mm.	In.	mm.	In.	mm.	In.	mm.	In.	mm.
H	2.500	63.50	2.236	56.79	1.800	45.72	1.450	36.83	2.045	51.94
L	2.736	69.49	2.472	62.79	2.036	51.71	1.686	42.82	2.281	57.94

Dimensions in inches (millimeters) and are subject to change without notice.

240-790-071
 Series 79 Filtered Receptacle
 Rear Panel Mount with Solder Cup Termination



Series 79
 Micro-Crimp

240-790-071P SHELL SIZE M DIMENSIONS

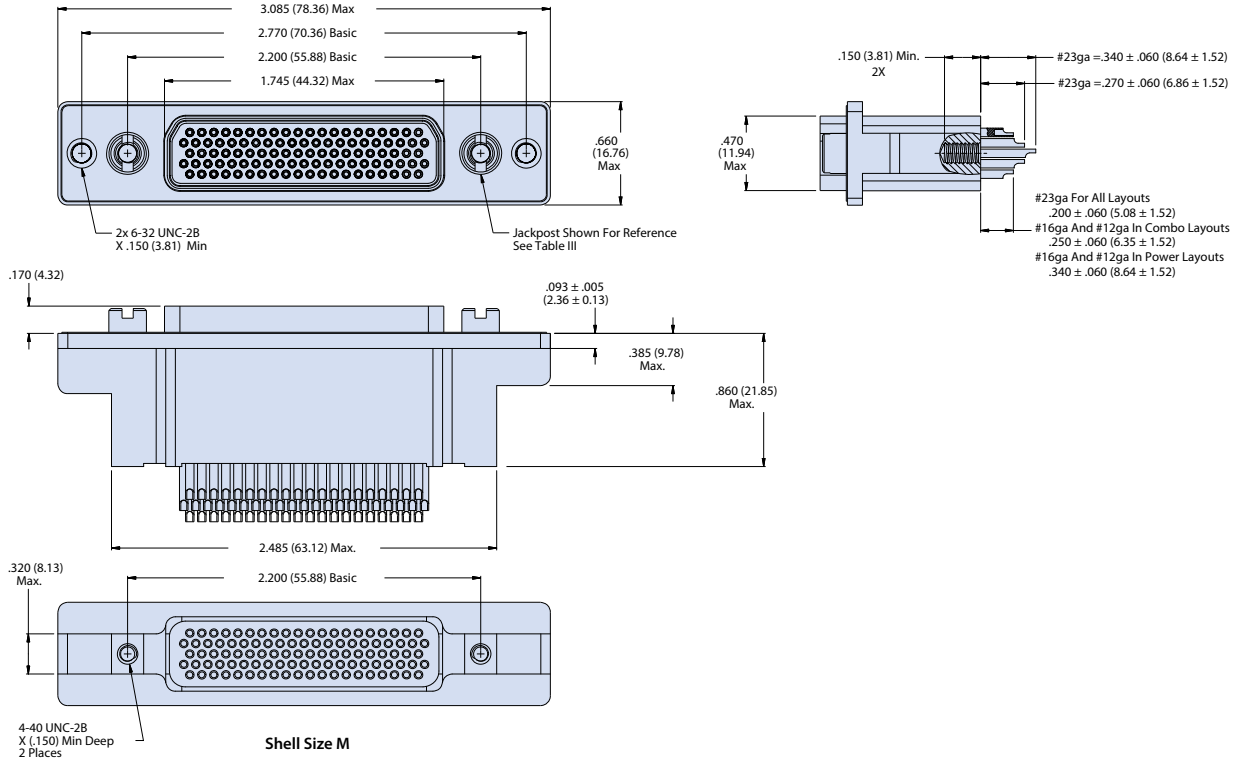

Dimensions in inches (millimeters) and are subject to change without notice.

© 2013 Glenair, Inc.

U.S. CAGE Code 06324

Printed in U.S.A.

240-790-072
Series 79 Filtered Plug
 Rear Panel Mount with Solder Cup Termination



Table I: Contact Arrangements

Layout	Contact Quantity			Face View
	#23	#16	#12	
A-5	5			
B-2P2		2		
B-9	9			
C-13	13			
D-15	15			
D-3P3		3		
D-7P2	5	2		
E-11P2	9	2		
E-19	19			
E-7P3	4	3		
F-15P2	13	2		
F-23	23			
F-5P5		5		
G-33	33			
H-10P4	6		4	
H-29P7	22	7		
H-36P2	34		2	
H-54P2	52	2		
H-5P5			5	
H-66	66			
J-17P4	13	4		
J-25P2	23	2		
J-33	33			
J-7P7		7		
K-27P4	23	4		
K-35P2	33	2		
K-43	43			
K-9P9		9		
L-6P6			6	
L-78	78			
M-102	102			

Table II: Capacitor Array Code / Capacitance Range

Class	Pi - Circuit (pF)	C - Circuit (pF)
X*†	160,000 - 240,000	80,000 - 120,000
Y*	80,000 - 120,000	40,000 - 60,000
Z*	60,000 - 90,000	30,000 - 45,000
A	38,000 - 56,000	19,000 - 28,000
B	32,000 - 45,000	16,000 - 22,500
C	18,000 - 33,000	9,000 - 16,500
D	8,000 - 12,000	4,000 - 6,000
E	3,300 - 5,000	1,650 - 2,500
F	800 - 1,300	400 - 650
G	400 - 600	200 - 300
J	70-120	35-60

* Filter Classes X, Y and Z are 250 VDC.
 All others are 500 VDC
 † Class X filters not available for insert arrangements with 3 or more rows of contacts

Blind mate

SHELL SIZES A, B, C, D, E, F, G, J, K

± .030 (0.76) Allowable misalignment from centerline

SHELL SIZES H, L

± .040 (1.02) Allowable misalignment from centerline

SHELL SIZE M

± .050 (1.27) Allowable misalignment from centerline



Table III: Hardware Option

N No Mating Hardware		Connector supplied with blind tapped holes. .150" (3.8 mm) minimum depth. Shell size M has #8-32 UNC-2B thread. Shell sizes H and L have #6-32 UNC-2B thread. All other sizes have #4-40 UNC-2B thread.
P Jackposts		Connector is supplied with non-removable stainless steel jackposts. Shell size M has 6-32-UNC thread. Shell sizes H and L have #4-40 UNC-2B thread. All other sizes have #2-56 UNC-2B thread.
G Guide Pins		Connector is supplied with stainless steel non-removable guide pins for blind mate applications. Mates with type "S" guide sockets on corresponding plug connector.
S Guide Sockets		Connector is supplied with stainless steel non-removable bushings for blind mate applications. Mates with type "G" guide pins on corresponding plug connector.

Dimensions in inches (millimeters) and are subject to change without notice.



240-790-072S SHELL SIZE A, B, C, D, E, F, J AND K DIMENSIONS

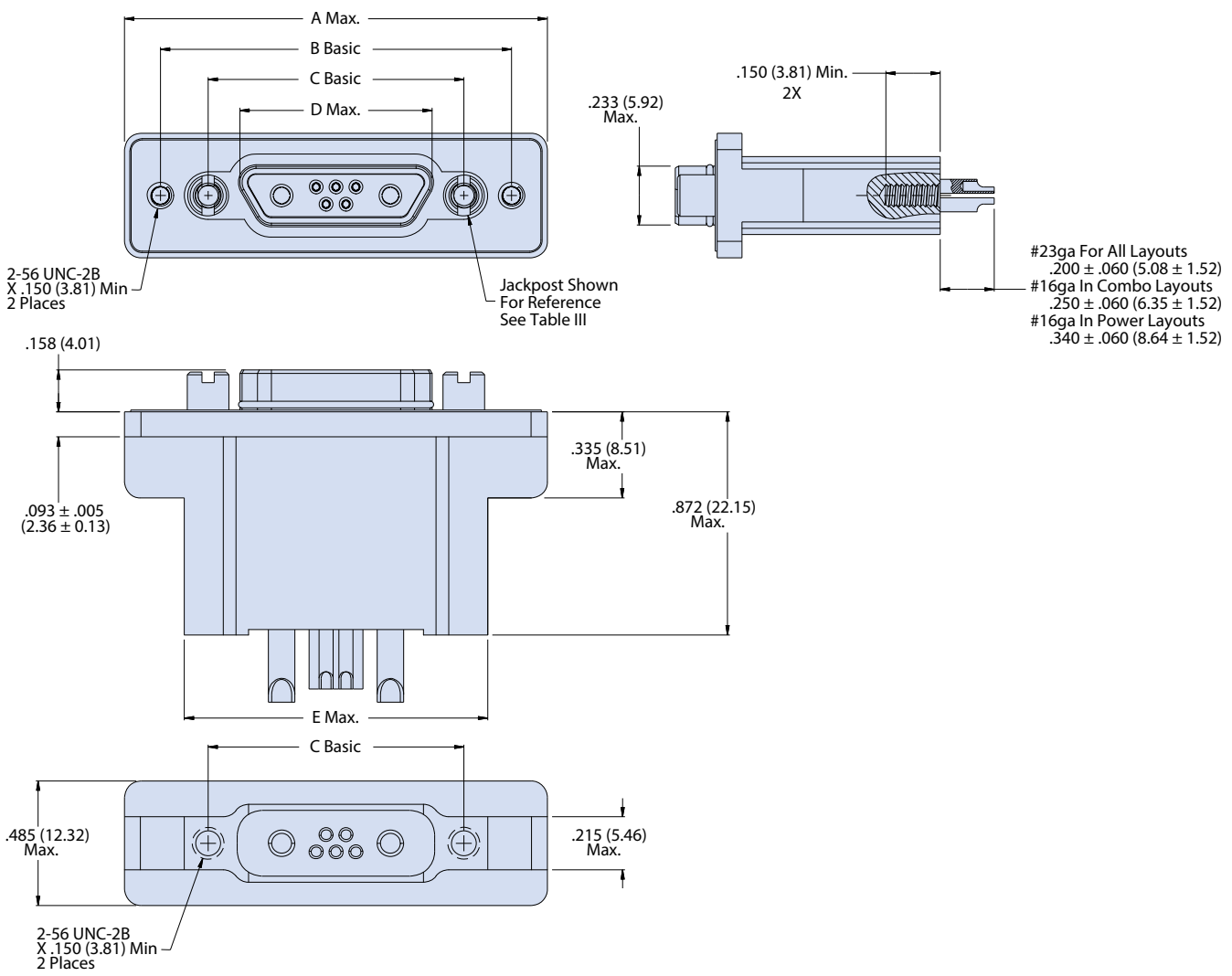

Shell Sizes A,B,C,D,E,F,J,K

790-072S Dimensions for Size A-F, J and K										
Shell Size	A Max.		B Basic		C Basic		D Max.		E Max.	
	In.	mm.	In.	mm.	In.	mm.	In.	mm.	In.	mm.
A	1.211	30.76	.925	23.50	.565	14.35	.335	8.51	.760	19.30
B	1.361	34.57	1.075	27.31	.715	18.16	.485	12.32	.910	23.11
C	1.511	38.38	1.225	31.12	.865	21.97	.635	16.13	1.060	26.92
D	1.611	40.92	1.325	33.66	.965	24.51	.735	18.67	1.160	29.46
E	1.761	44.73	1.475	37.47	1.115	28.32	.885	22.48	1.310	33.27
F	1.911	48.54	1.625	41.28	1.265	32.13	1.035	26.29	1.460	37.08
J	2.261	57.43	1.975	50.17	1.615	41.02	1.390	35.31	1.810	45.97
K	2.661	67.59	2.375	60.33	2.015	51.18	1.795	45.59	2.210	56.13

Dimensions in inches (millimeters) and are subject to change without notice.

240-790-072
 Series 79 Filtered Plug
 Rear Panel Mount with Solder Cup Termination



Series 79
 Micro-Crimp

240-790-072S SHELL SIZE G DIMENSIONS

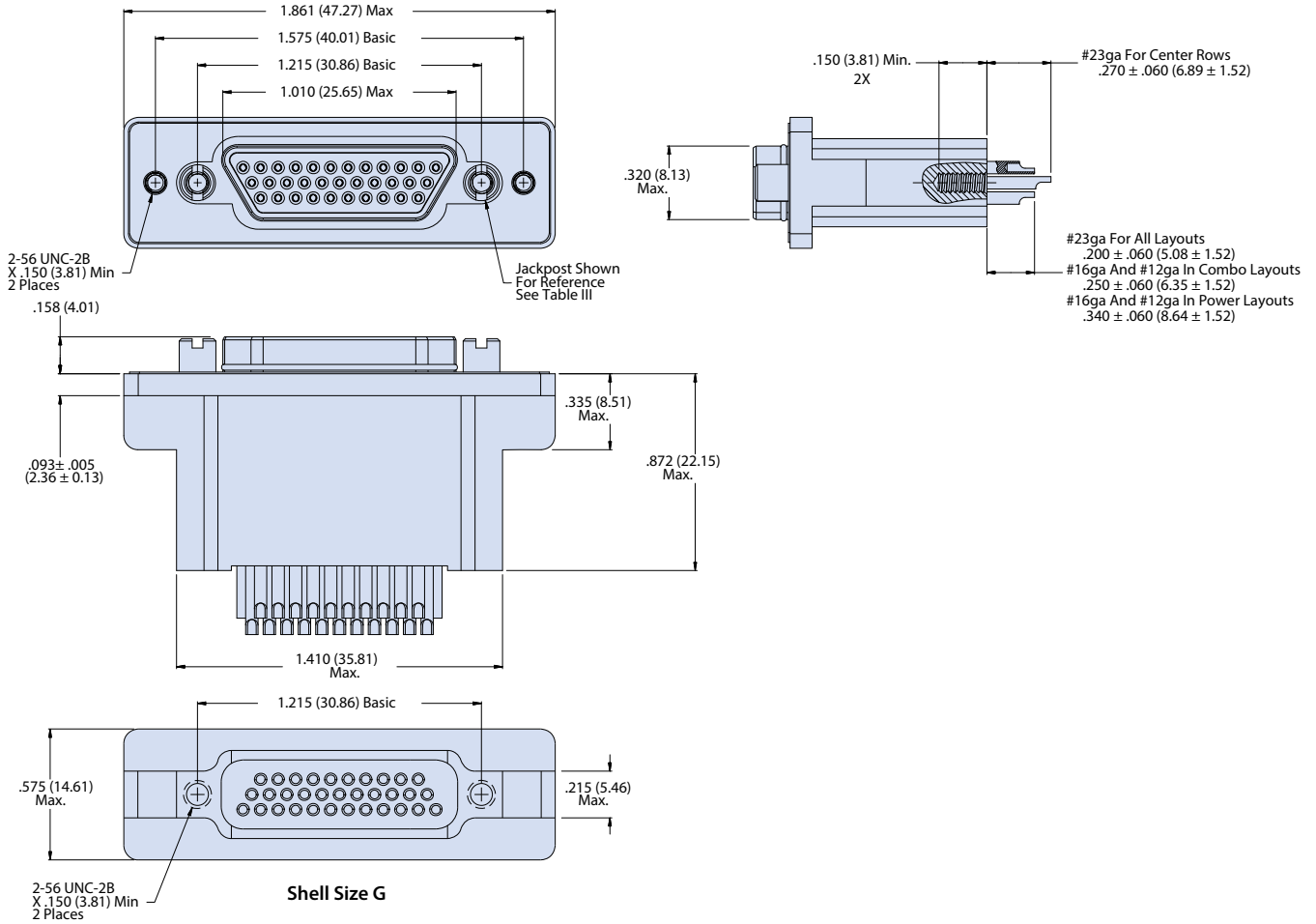

Dimensions in inches (millimeters) and are subject to change without notice.

© 2013 Glenair, Inc.

U.S. CAGE Code 06324

Printed in U.S.A.



240-790-072S SHELL SIZE H AND L DIMENSIONS

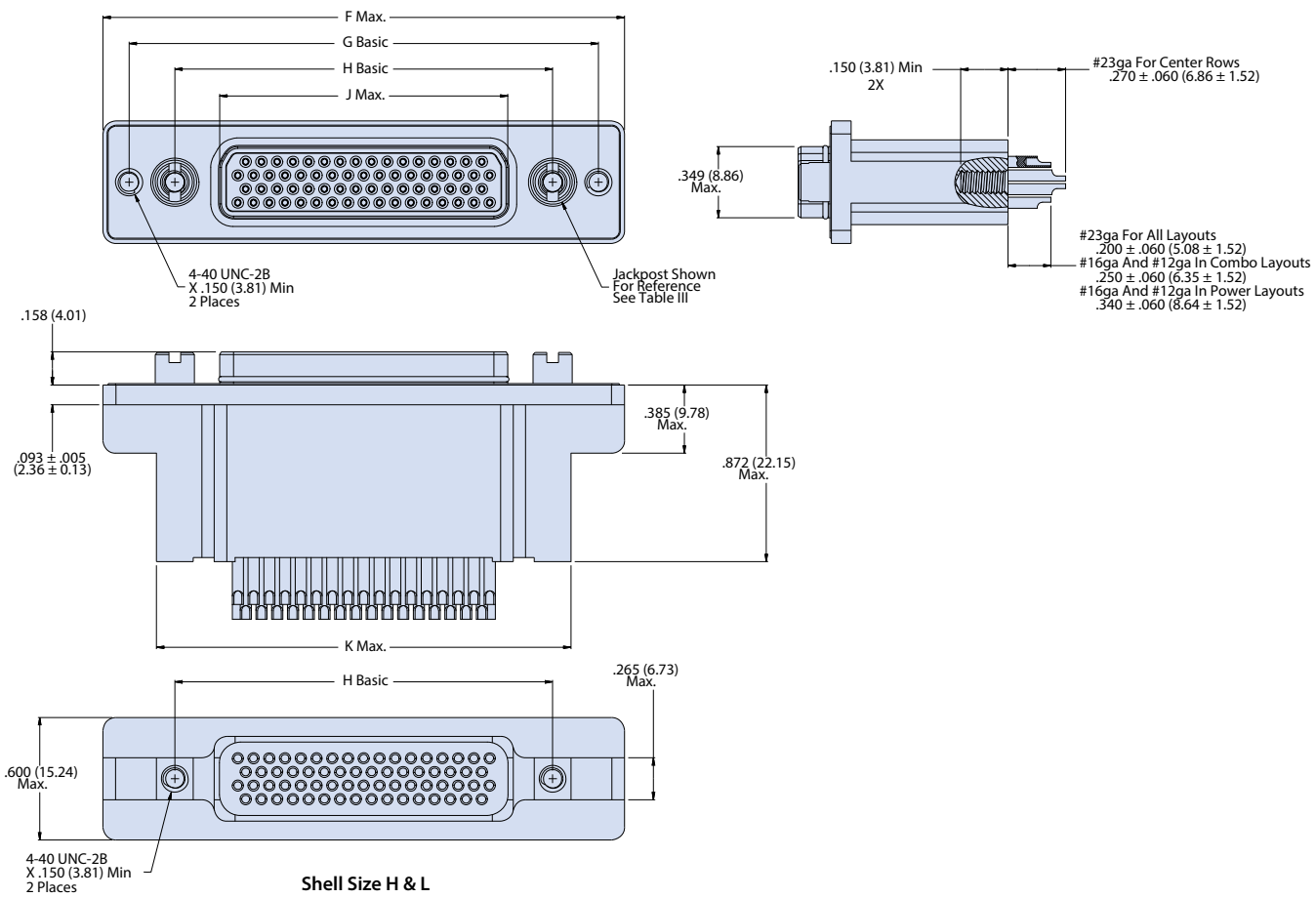

790-072S Size H & L Dimensions										
Shell Size	F Max.		G Basic		H Basic		J Max.		K Max.	
	In.	mm.	In.	mm.	In.	mm.	In.	mm.	In.	mm.
H	2.500	63.50	2.236	56.79	1.800	45.72	1.385	35.18	2.045	51.94
L	2.736	69.49	2.472	62.79	2.036	51.71	1.623	41.22	2.281	57.94

Dimensions in inches (millimeters) and are subject to change without notice.

240-790-072
 Series 79 Filtered Plug
 Rear Panel Mount with Solder Cup Termination



Series 79
 Micro-Crimp

240-790-072S SHELL SIZE M DIMENSIONS

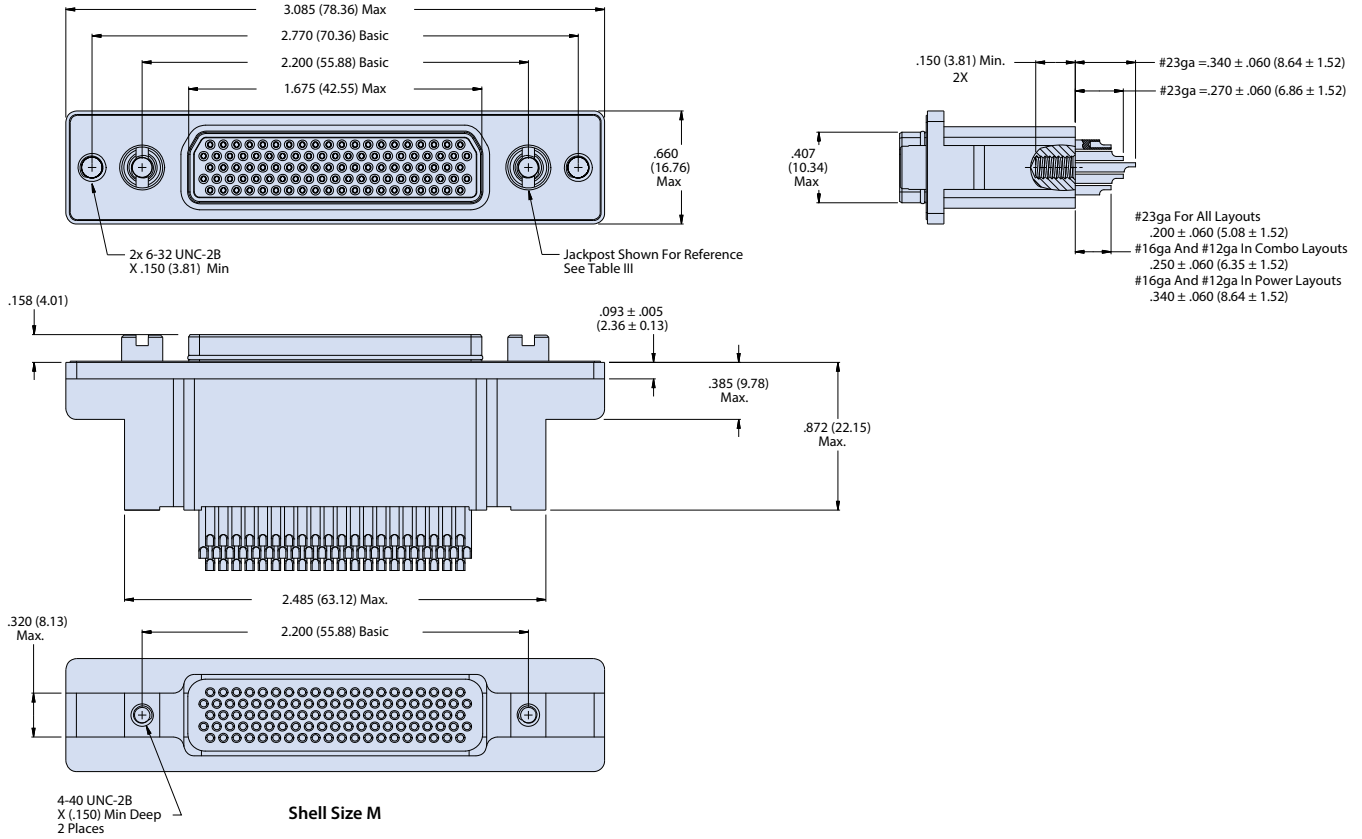

Dimensions in inches (millimeters) and are subject to change without notice.

© 2013 Glenair, Inc.

U.S. CAGE Code 06324

Printed in U.S.A.

SERIES 240



ARINC Filter Connectors

Fast, reliable in-house manufacturing



Glenair manufactures a full range of ARINC 600 filter connectors for use in EMC/EMP management of electronic systems and interconnect cabling. All connectors are designed in accordance with the ARINC 600 specification, and are designed to mate with ARINC 600 plugs with the same insert configuration and opposite contact gender. Planar filter arrays and TVS diodes may be integrated into both standard catalog as well as build-to-order configurations. Glenair's state-of-the-art diode burn-in process tests leaded and surface mount diodes with leakage current monitored throughout the entire test procedure ensuring field reliability.



Glenair, Inc.
1211 Air Way
Glendale, CA
91201-2497
818-247-6000
sales@glenair.com
www.glenair.com

240-601
Page H-2

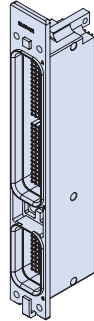

ARINC 600 Size 1 Environmentally Compatible Filter Receptacle

240-602
Page H-4

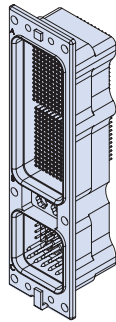

ARINC 600 Size 2 Environmentally Compatible Filter Receptacle

240-603
Page H-6

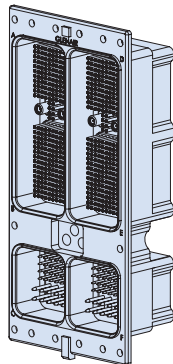

ARINC 600 Size 3 Environmentally Compatible Filter Receptacle

Dimensions in inches (millimeters) and are subject to change without notice.



240-601
ARINC 600 Size 1
Environmentally Compatible Filter Receptacle

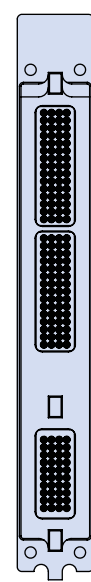
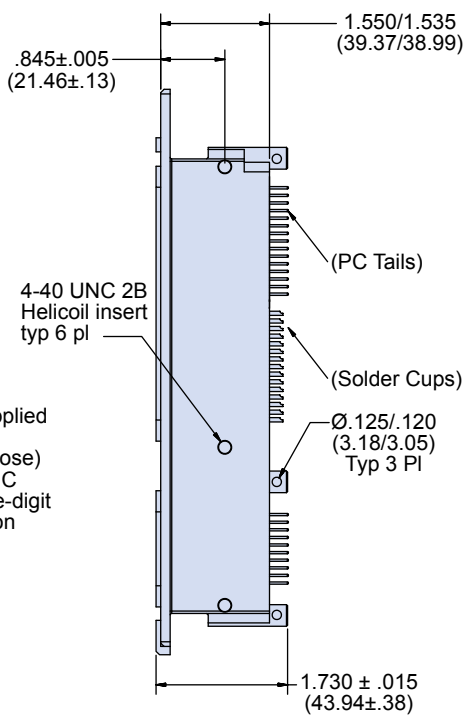
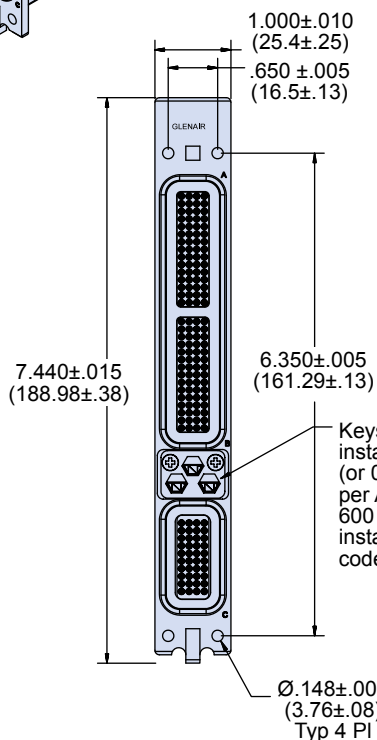
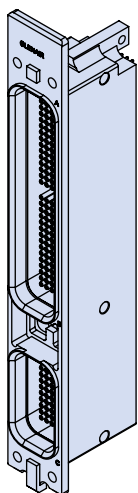
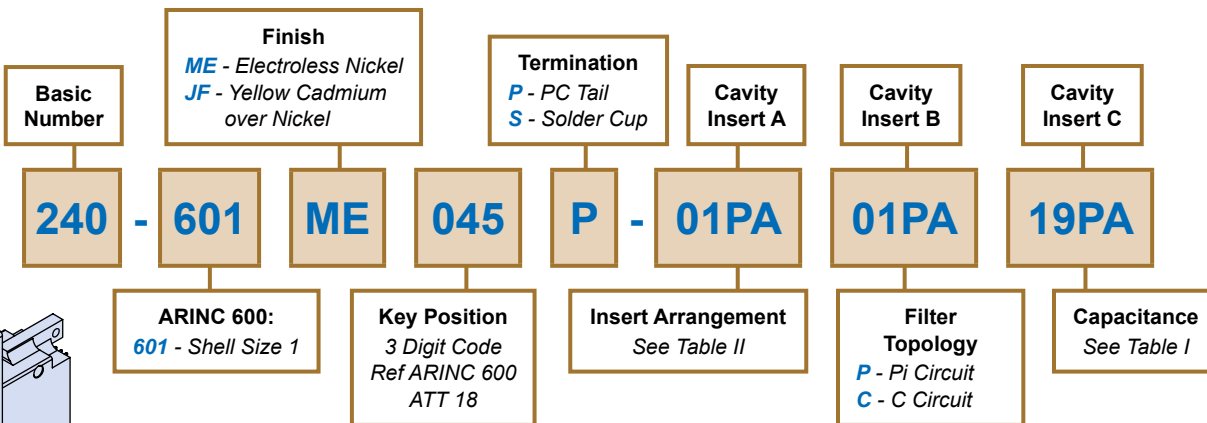

Dimensions in inches (millimeters) and are subject to change without notice.

240-601
ARINC 600 Size 1
Environmentally Compatible Filter Receptacle



Table II: Insert Arrangements

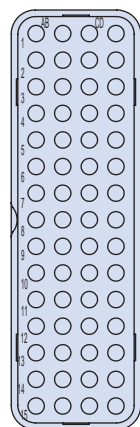

Insert 01
60 #22

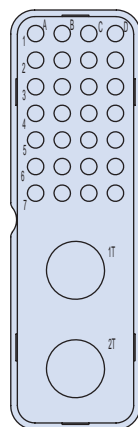

Insert 20
30 #22
2 #8

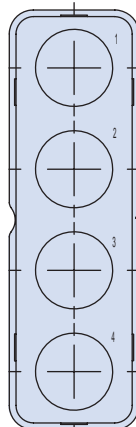

Insert 27
4 #8

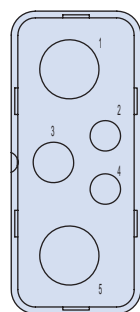

Insert 03
2 #5 Coax
1 #12
2 #16

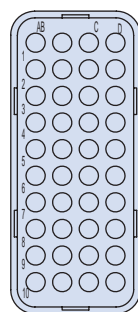

Insert 19
40 #22

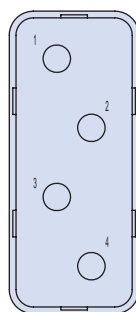

Insert 21
4 #12

Insert contains grounded coax non-filtered

Table I: Capacitor Array Code / Capacitance Range

Class	Pi - Circuit (pF)	C - Circuit (pF)
X	160,000 - 240,000	80,000 - 120,000
Y	80,000 - 120,000	40,000 - 60,000
Z	60,000 - 90,000	30,000 - 45,000
A	38,000 - 56,000	19,000 - 28,000
B	32,000 - 45,000	16,000 - 22,500
C	18,000 - 33,000	9,000 - 16,500
D	8,000 - 12,000	4,000 - 6,000
E	3,300 - 5,000	1,650 - 2,500
F	800 - 1,300	400 - 650
G	400 - 600	200 - 300
J	70-120	35-60



Notes

- Glenair ARINC 600 receptacle is designed to mate with COTS ARINC 600 plug IAW ARINC 600 specification with the same insert configuration
- Material/Finish:
Shell: Aircraft Grade Aluminum
Insulators: High Grade Rigid Dielectric
PC Tail and Solder Cup Contacts: Copper Alloy/Gold over Nickel
- Assembly to be permanently identified with (space permitting) Glenair, part number, cavity and contact location, and date code.
- Insert arrangement in accordance with ARINC 600 (arrangement shown for reference only)
- EMI filter receptacle connector designed to meet requirements of MIL-STD-2120 and ARINC 600.
- Electrical Parameters:
Working Voltage - 200 VDC, 115 VAC 400Hz
Dielectric Withstanding Voltage (DWV) - 500 VDC
Insulation Resistance (IR) - 5000 Megohms min at 200 VDC
- Custom filter types available (consult factory).
- Additional mounting features available (consult factory).
- Environmental compatibility features:
Single piece shell to limit any contaminants or moisture ingress due to post-processing such as solder wash.
Termination area sealed via o-rings around each module.
Termination may utilize sealing compound to further aid in environmental compatibility

Dimensions in inches (millimeters) and are subject to change without notice.

240-602
ARINC 600 Size 2
Environmentally Compatible Filter Receptacle

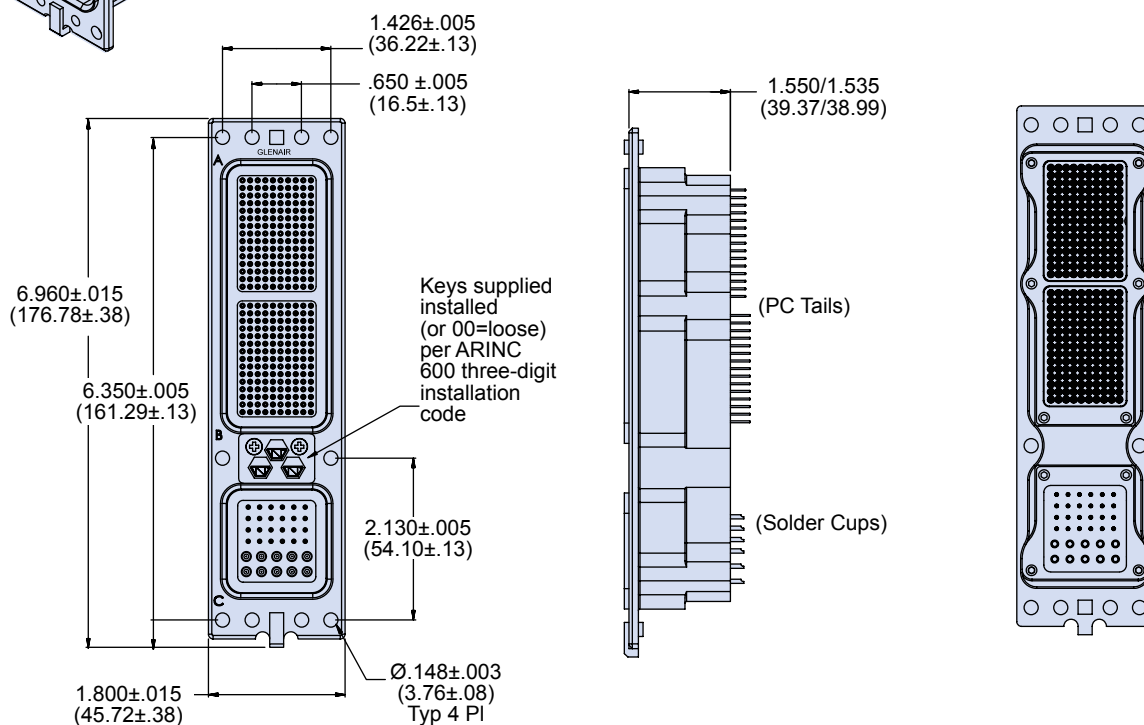
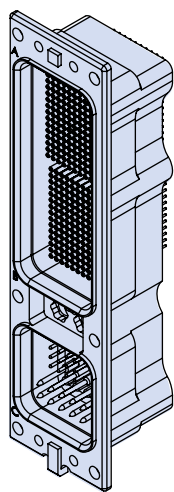
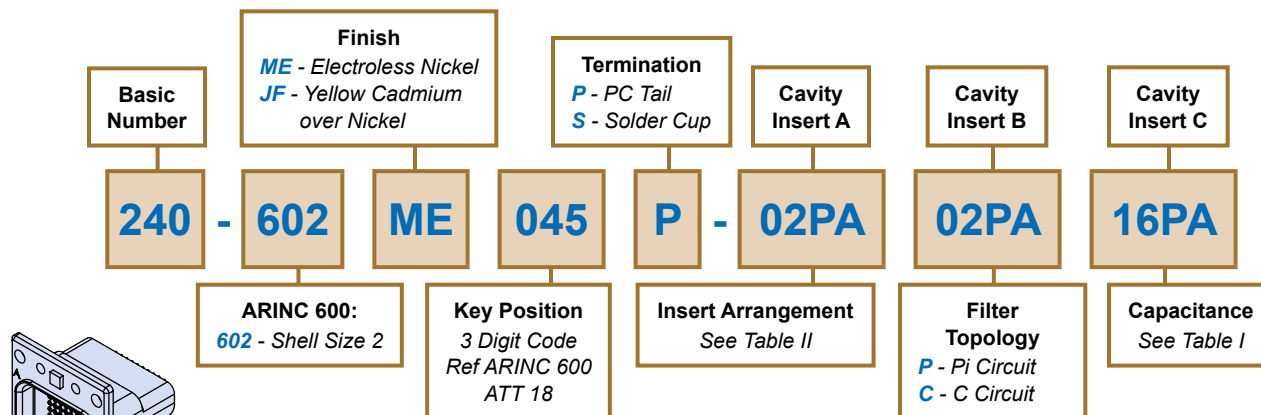

Dimensions in inches (millimeters) and are subject to change without notice.

240-602
ARINC 600 Size 2
Environmentally Compatible Filter Receptacle



Table II: Insert Arrangements

Insert 07 100 #22	Insert 24 20 #20 4 #8 Twinax	Insert 16 24 #20 10 #16	Insert 13 6 #8 Twinax (Grounded)	Insert blank (for cavity C)	Insert 22 50 #16 4 #12	Insert 04 2 #5 4 #12 3 #16 4 #20	
Insert 02 150 #22	Insert 15 110 #22 6 #20 5 #12 (Twinax)	Insert 05 70 #22 1 #5 (Coax)	Insert 08 70 #22 1 #5 (Coax)	Insert blank (for cavity A, B)	Insert 17 60 #20	Insert 12 10 #8 Twinax (grounded)	Insert 14 118 #22 2 #8 (Twinax)

Table I: Capacitor Array Code / Capacitance Range

Class	Pi - Circuit (pF)	C - Circuit (pF)
X	160,000 - 240,000	80,000 - 120,000
Y	80,000 - 120,000	40,000 - 60,000
Z	60,000 - 90,000	30,000 - 45,000
A	38,000 - 56,000	19,000 - 28,000
B	32,000 - 45,000	16,000 - 22,500
C	18,000 - 33,000	9,000 - 16,500
D	8,000 - 12,000	4,000 - 6,000
E	3,300 - 5,000	1,650 - 2,500
F	800 - 1,300	400 - 650
G	400 - 600	200 - 300
J	70-120	35-60

Notes

- Glenair ARINC 600 receptacle is designed to mate with COTS ARINC 600 plug IAW ARINC 600 specification with the same insert configuration
- Material/Finish:
Shell: Aircraft Grade Aluminum
Insulators: High Grade Rigid Dielectric
PC Tail and Solder Cup Contacts: Copper Alloy/Gold over Nickel
- Assembly to be permanently identified with (space permitting) Glenair, part number, cavity and contact location, and date code.
- Insert arrangement in accordance with ARINC 600
- EMI filter receptacle connector designed to meet or exceed requirements of MIL-STD-2120 and ARINC 600.
- Electrical Parameters:
Working Voltage - 200 VDC, 115 VAC 400Hz
Dielectric Withstanding Voltage (DWV) - 500 VDC
Insulation Resistance (IR) - 5000 Megohms min at 200 VDC
- Custom filter types available (consult factory).
- Additional mounting features available (consult factory).
- Environmental compatibility features:
Single piece shell to limit any contaminants or moisture ingress due to post-processing such as solder wash.
Termination area sealed via o-rings around each module.
Termination may utilize sealing compound to further aid in environmental compatibility

Dimensions in inches (millimeters) and are subject to change without notice.





240-603
ARINC 600 Size 3
Environmentally Compatible Filter Receptacle

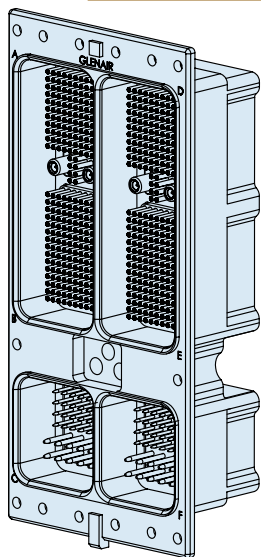
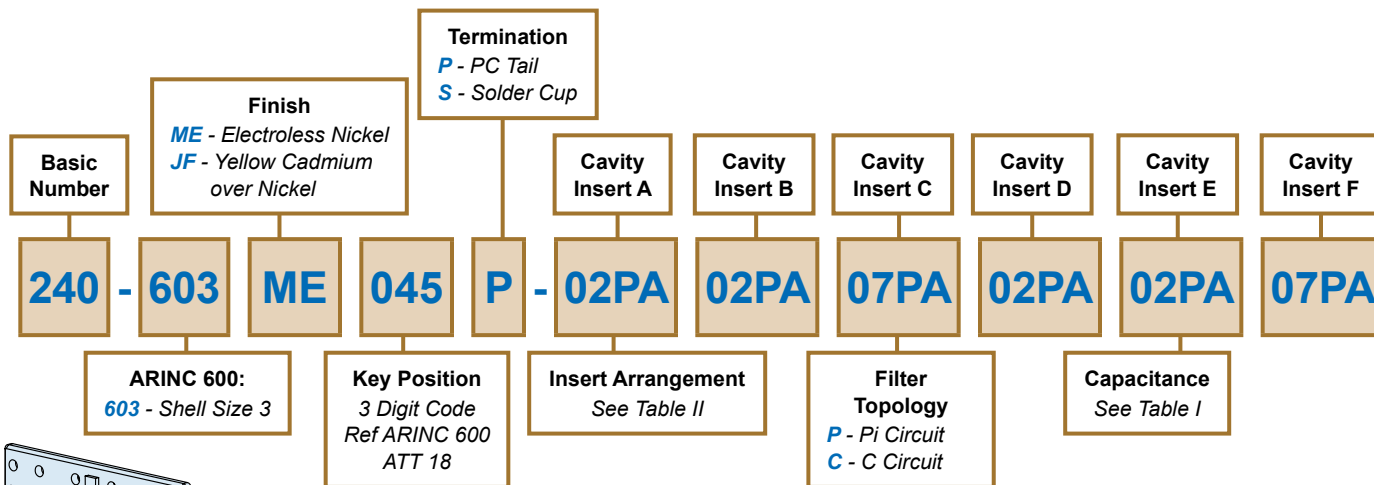

H

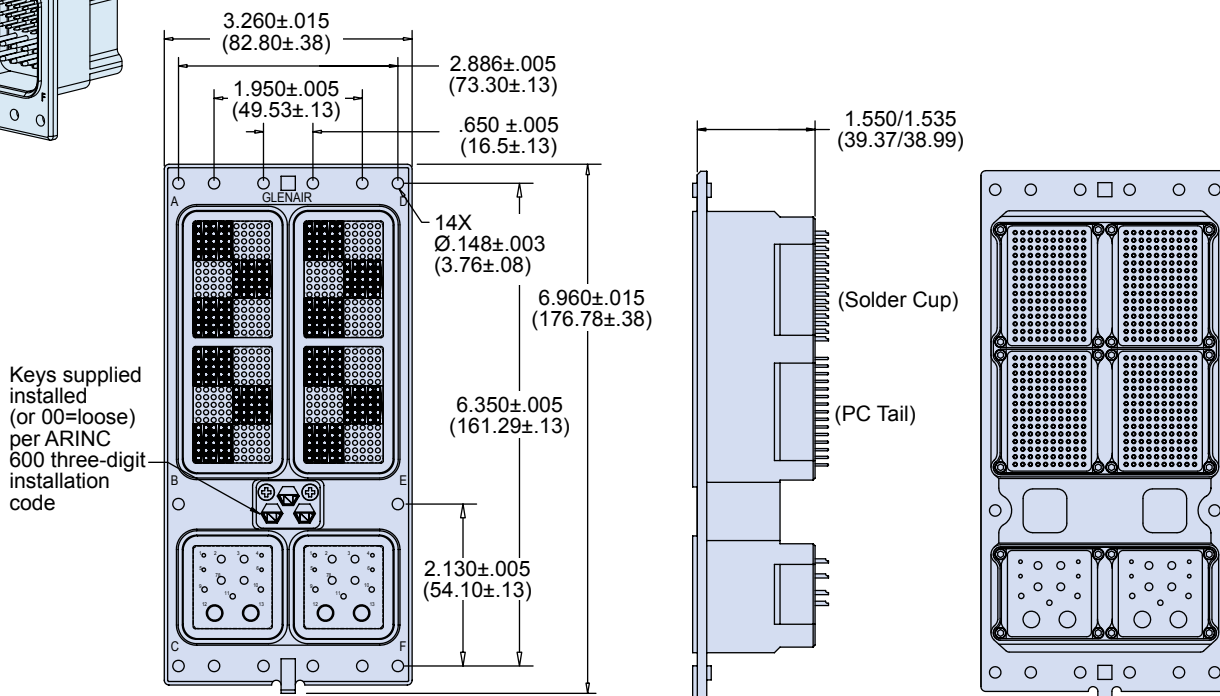

Dimensions in inches (millimeters) and are subject to change without notice.

240-603
ARINC 600 Size 3
Environmentally Compatible Filter Receptacle



Table II: Insert Arrangements

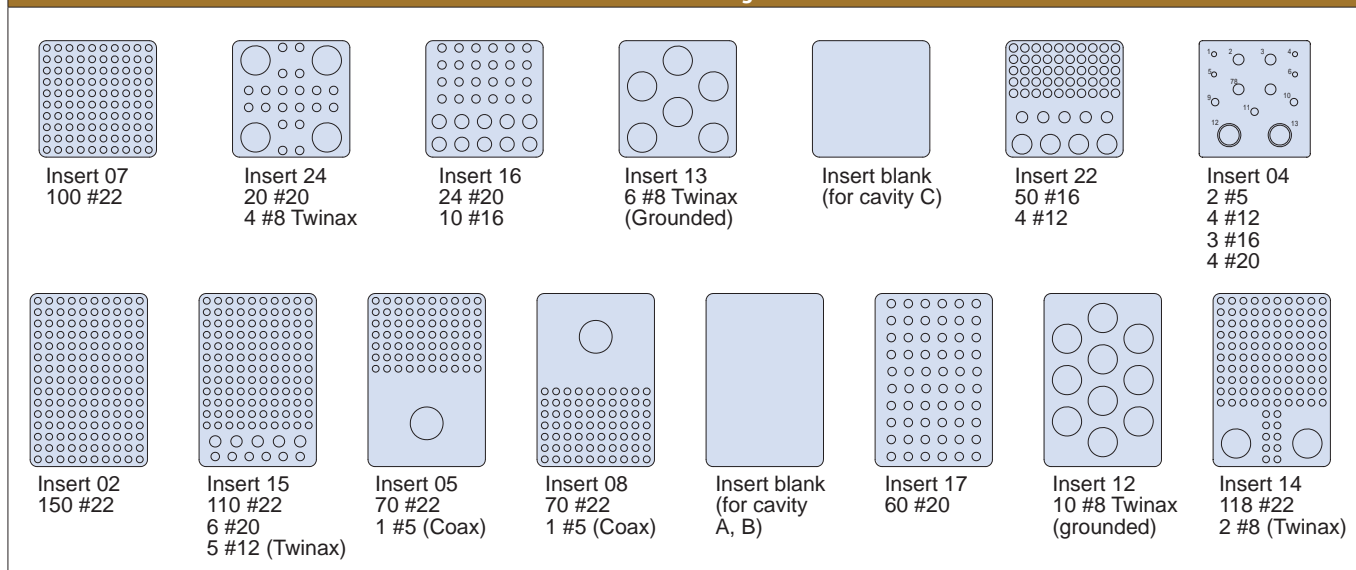

Table I: Capacitor Array Code / Capacitance Range

Class	Pi - Circuit (pF)	C - Circuit (pF)
X	160,000 - 240,000	80,000 - 120,000
Y	80,000 - 120,000	40,000 - 60,000
Z	60,000 - 90,000	30,000 - 45,000
A	38,000 - 56,000	19,000 - 28,000
B	32,000 - 45,000	16,000 - 22,500
C	18,000 - 33,000	9,000 - 16,500
D	8,000 - 12,000	4,000 - 6,000
E	3,300 - 5,000	1,650 - 2,500
F	800 - 1,300	400 - 650
G	400 - 600	200 - 300
J	70-120	35-60

Notes

- Glenair ARINC 600 receptacle is designed to mate with COTS ARINC 600 plug IAW ARINC 600 specification with the same insert configuration and opposite gender
- Material/Finish:
Shell: Aircraft Grade Aluminum
Insulators: High Grade Rigid Dielectric
PC Tail and Solder Cup Contacts: Copper Alloy/Gold over Nickel
- Assembly to be permanently identified with (space permitting) Glenair, part number, cavity and contact location, and date code.
- Insert arrangement in accordance with ARINC 600
- EMI filter receptacle connector designed to meet or exceed requirements of MIL-STD-2120 and ARINC 600.
- Electrical Parameters:
Working Voltage - 200 VDC, 115 VAC 400Hz
Dielectric Withstanding Voltage (DWV) - 500 VDC
Insulation Resistance (IR) - 5000 Megohms min at 200 VDC
- Custom filter types available (consult factory).
- Additional mounting features available (consult factory).
- Environmental compatibility features:
Single piece shell to limit any contaminants or moisture ingress due to post-processing such as solder wash.
Termination area sealed via o-rings around each module.
Termination may utilize sealing compound to further aid in environmental compatibility.

Dimensions in inches (millimeters) and are subject to change without notice.





ARINC 600 Connectors Polarizing Positions of Available Keying Positions

Position	Plug			Receptacle		
	Left Post	Center Post	Right Post	Left Post	Center Post	Right Post
00	•	•	•	•	•	•
01	1	1	1	4	4	4
02	2	1	1	4	4	3
03	3	1	1	4	4	2
04	4	1	1	4	4	1
05	5	1	1	4	4	6
06	6	1	1	4	4	5
07	1	1	6	5	4	4
08	2	1	6	5	4	3
09	3	1	6	5	4	2
10	4	1	6	5	4	1
11	5	1	6	5	4	6
12	6	1	6	5	4	5
13	1	1	5	6	4	4
14	2	1	5	6	4	3
15	3	1	5	6	4	2
16	4	1	5	6	4	1
17	5	1	5	6	4	6
18	6	1	5	6	4	5
19	1	1	4	1	4	4
20	2	1	4	1	4	3
21	3	1	4	1	4	2
22	4	1	4	1	4	1
23	5	1	4	1	4	6
24	6	1	4	1	4	5
25	1	1	3	2	4	4
26	2	1	3	2	4	3
27	3	1	3	2	4	2
28	4	1	3	2	4	1
29	5	1	3	2	4	6
30	6	1	3	2	4	5
31	1	1	2	3	4	4
32	2	1	2	3	4	3
33	3	1	2	3	4	2
34	4	1	2	3	4	1
35	5	1	2	3	4	6
36	6	1	2	3	4	5
37	1	2	1	4	3	4
38	2	2	1	4	3	3
40	4	2	1	4	3	1
41	5	2	1	4	3	6
42	6	2	1	4	3	5
43	1	2	6	5	3	4
44	2	2	6	5	3	3
45	3	2	6	5	3	2
46	4	2	6	5	3	1
47	5	2	6	5	3	6
48	6	2	6	5	3	5
49	1	2	5	6	3	4
50	2	2	5	6	3	3
51	3	2	5	6	3	2
52	4	2	5	6	3	1
53	5	2	5	6	3	6
54	6	2	5	6	3	5

Position	Plug			Receptacle		
	Left Post	Center Post	Right Post	Left Post	Center Post	Right Post
55	1	2	4	1	3	4
56	2	2	4	1	3	3
57	3	2	4	1	3	2
58	4	2	4	1	3	1
59	5	2	4	1	3	6
60	6	2	4	1	3	5
61	1	2	3	2	3	4
62	2	2	3	2	3	3
63	3	2	3	2	3	2
64	4	2	3	2	3	1
65	5	2	3	2	3	6
66	6	2	3	2	3	5
67	1	2	2	3	3	4
68	2	2	2	3	3	3
69	3	2	2	3	3	2
70	4	2	2	3	3	1
71	5	2	2	3	3	6
72	6	2	2	3	3	5
73	1	3	1	4	2	4
74	2	3	1	4	2	3
75	3	3	1	4	2	2
76	4	3	1	4	2	1
77	5	3	1	4	2	6
78	6	3	1	4	2	5
79	1	3	6	5	2	4
80	2	3	6	5	2	3
81	3	3	6	5	2	2
82	4	3	6	5	2	1
83	5	3	6	5	2	6
84	6	3	6	5	2	5
85	1	3	5	6	2	4
86	2	3	5	6	2	3
87	3	3	5	6	2	2
88	4	3	5	6	2	1
89	5	3	5	6	2	6
90	6	3	5	6	2	5
91	1	3	4	1	2	4
92	2	3	4	1	2	3
93	3	3	4	1	2	2
94	4	3	4	1	2	1
95	5	3	4	1	2	6
96	6	3	4	1	2	5
97	1	3	3	2	2	4
98	2	3	3	2	2	3
99	3	3	3	2	2	2
100	4	3	3	2	2	1
101	5	3	3	2	2	6
102	6	3	3	2	2	5
103	1	3	2	3	2	4
104	2	3	2	3	2	3
105	3	3	2	3	2	2
106	4	3	2	3	2	1
107	5	3	2	3	2	6
108	6	3	2	3	2	5

Dimensions in inches (millimeters) and are subject to change without notice.

ARINC 600 Connectors Polarizing Positions of Available Keying Positions



Position	Plug			Receptacle		
	Left Post	Center Post	Right Post	Left Post	Center Post	Right Post
109	1	4	1	4	1	4
110	2	4	1	4	1	3
111	3	4	1	4	1	2
112	4	4	1	4	1	1
113	5	4	1	4	1	6
114	6	4	1	4	1	5
115	1	4	6	5	1	4
116	2	4	6	5	1	3
117	3	4	6	5	1	2
118	4	4	6	5	1	1
119	5	4	6	5	1	6
120	6	4	6	5	1	5
121	1	4	5	6	1	4
122	2	4	5	6	1	3
123	3	4	5	6	1	2
124	4	4	5	6	1	1
125	5	4	5	6	1	6
126	6	4	5	6	1	5
127	1	4	4	1	1	4
128	2	4	4	1	1	3
129	3	4	4	1	1	2
130	4	4	4	1	1	1
131	5	4	4	1	1	6
132	6	4	4	1	1	5
133	1	4	3	2	1	4
134	2	4	3	2	1	3
135	3	4	3	2	1	2
136	4	4	3	2	1	1
137	5	4	3	2	1	6
138	6	4	3	2	1	5
139	1	4	2	3	1	4
140	2	4	2	3	1	3
141	3	4	2	3	1	2
142	4	4	2	3	1	1
143	5	4	2	3	1	6
144	6	4	2	3	1	5
145	1	5	1	4	6	4
146	2	5	1	4	6	3
147	3	5	1	4	6	2
148	4	5	1	4	6	1
149	5	5	1	4	6	6
150	6	5	1	4	6	5
151	1	5	6	5	6	4
152	2	5	6	5	6	3
153	3	5	6	5	6	2
154	4	5	6	5	6	1
155	5	5	6	5	6	6
156	6	5	6	5	6	5
157	1	5	5	6	6	4
158	2	5	5	6	6	3
159	3	5	5	6	6	2
160	4	5	5	6	6	1
161	5	5	5	6	6	6
162	6	5	5	6	6	5

Position	Plug			Receptacle		
	Left Post	Center Post	Right Post	Left Post	Center Post	Right Post
163	1	5	4	1	6	4
164	2	5	4	1	6	3
165	3	5	4	1	6	2
166	4	5	4	1	6	1
167	5	5	4	1	6	6
168	6	5	4	1	6	5
169	1	5	3	2	6	4
170	2	5	3	2	6	3
171	3	5	3	2	6	2
172	4	5	3	2	6	1
173	5	5	3	2	6	6
174	6	5	3	2	6	5
175	1	5	2	3	6	4
176	2	5	2	3	6	3
177	3	5	2	3	6	2
178	4	5	2	3	6	1
179	5	5	2	3	6	6
180	6	5	2	3	6	5
181	1	6	1	4	5	4
182	2	6	1	4	5	3
183	3	6	1	4	5	2
184	4	6	1	4	5	1
185	5	6	1	4	5	6
186	6	6	1	4	5	5
187	1	6	6	5	5	4
188	2	6	6	5	5	3
189	3	6	6	5	5	2
190	4	6	6	5	5	1
191	5	6	6	5	5	6
192	6	6	6	5	5	5
193	1	6	5	6	5	4
194	2	6	5	6	5	3
195	3	6	5	6	5	2
196	4	6	5	6	5	1
197	5	6	5	6	5	6
198	6	6	5	6	5	5
199	1	6	4	1	5	4
200	2	6	4	1	5	3
201	3	6	4	1	5	2
202	4	6	4	1	5	1
203	5	6	4	1	5	6
204	6	6	4	1	5	5
205	1	6	3	2	5	4
206	2	6	3	2	5	3
207	3	6	3	2	5	2
208	4	6	3	2	5	1
209	5	6	3	2	5	6
210	6	6	3	2	5	5
211	1	6	2	3	5	4
212	2	6	2	3	5	3
213	3	6	2	3	5	2
214	4	6	2	3	5	1
215	5	6	2	3	5	6
216	6	6	2	3	5	5

Dimensions in inches (millimeters) and are subject to change without notice.



SERIES 240



TVS Filter Connectors

Configurable, fast-turnaround, catalog transient voltage suppression filter connectors



Glenair is the only manufacturer in the high-performance interconnect industry to offer transient voltage suppression interconnects as a fast-turnaround catalog item. These configurable TVS devices prevent catastrophic EMP failure in military and commercial aircraft for both EMP (electromagnetic pulse) as well as lightning protection. Lightweight and small form-factor designs save space and weight. Available configurations include D38999 type receptacles, plugs, and go-between adapters. All available versions may be custom configured to meet specific voltage, wattage, and clamping time requirements. Glenair catalog TVS connectors are designed in accordance with MIL-DTL-38999 electrical, mechanical, and environmental requirements, and mate with appropriate shell size and opposite contact gender connectors.



Glenair, Inc.
1211 Air Way
Glendale, CA
91201-2497
818-247-6000
sales@glenair.com
www.glenair.com

Product Selection Guide

242-383A
Page J-2

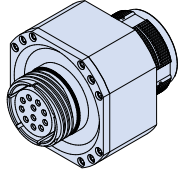

MIL-DTL-38999 Series III Type TVS Adapter

242-383P
Page J-4

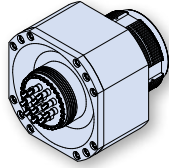

MIL-DTL-38999 Series III Type TVS Plug
with Solder Cup Contacts

242-383S
Page J-6

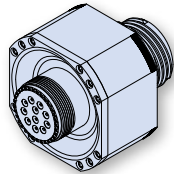

MIL-DTL-38999 Series III Type TVS Jam Nut Receptacle
with Crimp Contacts

244-001
Page J-8



MIL-DTL-38999 Series III Type TVS Jam Nut Receptacle with Front
RJ45 Jack to Rear Solder Cup or PC Tail Termination

244-002
Page J-9



SuperSeal™
MIL-DTL-38999 Series III Type TVS Jam Nut Receptacle with Front
RJ45 Jack to Rear Solder Cup or PC Tail Termination and Standoffs

244-003
Page J-10



SuperSeal™
MIL-DTL-38999 Series III Type TVS Jam Nut Receptacle with RJ45
Jack to Rear Solder Cup or PC Tail Termination and Standoffs

244-004
Page J-11



SuperSeal™
MIL-DTL-38999 Series III Type TVS Wall Mount Receptacle with
RJ45 Jack to Rear Solder Cup or PC Tail Termination and Standoffs

Dimensions in inches (millimeters) and are subject to change without notice.

D38999 SERIES III TYPE TVS ADAPTER

How To Order								
Sample Part Number	242-383	A	-XXXX	NF	19-11	PS	N	N
TVS Connector	MIL-DTL-38999 Series III							
Shell Style	A = Adapter							
Diode Net List	Assigned by Glenair. See Table V							
Connector Class	See Table II							
Insert Arrangement	IAW MIL-STD-1560							
Contact Gender	PS = Pins, Plug Side SP = Sockets, Plug Side							
Flange Mounting Style	N = Not Applicable							
Alternate Key Position	A, B, C, D, E, N = Normal, U = Universal (Do not mate Universal with Universal)							

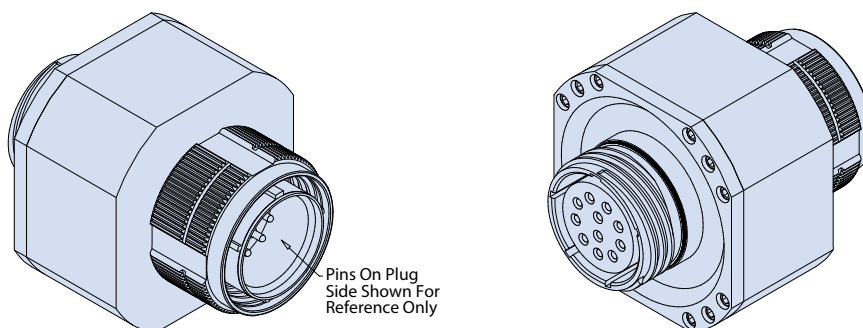

Notes

- Materials/Finishes: Shell Housing & Coupling Nut: See Table II
Ground Spring: Beryllium Copper Alloy/Electroless Nickel
Insulators: High grade rigid dielectric
Seals: Fluorosilicone
Contacts: Copper Alloy/Gold over Nickel per ASTM B 488
- Assembly to be identified with Glenair's name, part number, and date code - space permitting.
- Insert Arrangement in accordance with MIL-STD-1560. (Arrangement shown for reference only)
- Electrical Performance: Specific diode voltage code options per Table III. Diode wattage based on 10 x 1000 uS peak pulse power waveform.
Clamping Time: Less than 1 picosecond, 0V to min. breakdown.
- Glenair will assign a diode net list code and provide a separate net list drawing containing specific electrical requirements. Fill out applicable columns of Table V and return.
- Consult factory for low capacitance, ground requirements, power ratings above 5000W, special test requirements, or other modifications.
- Operating temperature: -55°C to +150°C

Dimensions in inches (millimeters) and are subject to change without notice.

242-383A
MIL-DTL-38999 Series III Type TVS Connector
Adapter

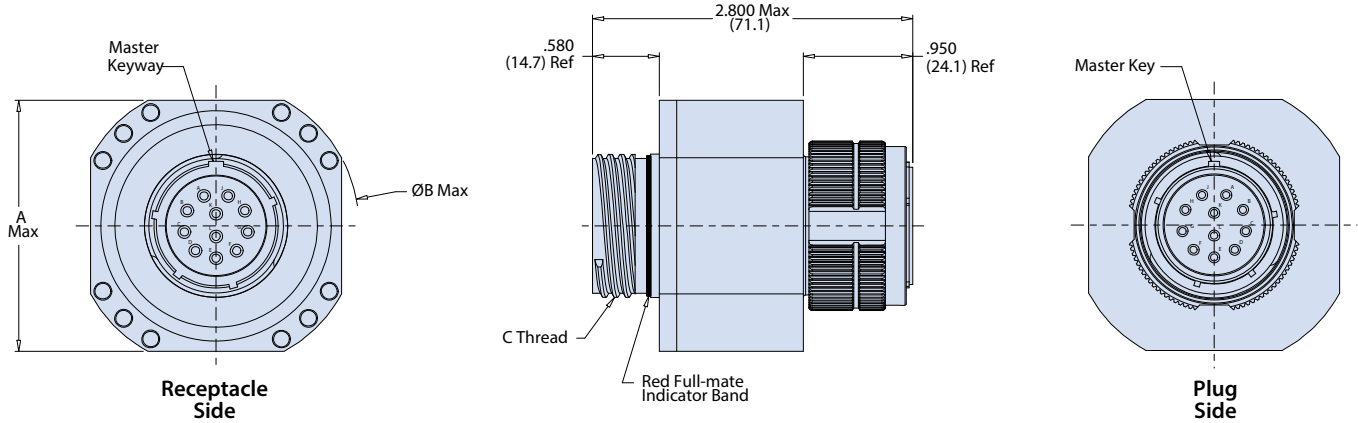

Shell Size	A Max	ØB Max	C Thread
9	1.000 (25.4)	1.300 (33.0)	.6250-.1P-.3L-TS-2A
11	1.400 (35.6)	1.700 (43.2)	.7500-.1P-.3L-TS-2A
13	1.700 (43.2)	2.000 (50.8)	.8750-.1P-.3L-TS-2A
15	1.700 (43.2)	2.000 (50.8)	1.0000-.1P-.3L-TS-2A
17	2.000 (50.8)	2.300 (58.4)	1.1875-.1P-.3L-TS-2A
19	2.200 (55.9)	2.500 (63.5)	1.2500-.1P-.3L-TS-2A
21	2.300 (58.4)	2.600 (66.0)	1.3750-.1P-.3L-TS-2A
23	2.600 (66.0)	2.900 (73.7)	1.5000-.1P-.3L-TS-2A
25	2.900 (73.7)	3.200 (81.3)	1.6250-.1P-.3L-TS-2A

Sym	Material	Finish Description
ME	Aluminum	Electroless Nickel
MT		Ni-PTFE 1000 Hour Grey™ Nickel Fluorocarbon Polymer
NF		Cadmium O.D. Over Electroless Nickel
ZN		Zinc-Nickel, Olive Drab
ZNU		Zinc Nickel, Black
ZR		Zinc Nickel, Black - RoHS
ZL		Stainless Steel

Dimensions in inches (millimeters) and are subject to change without notice.





242-383P MIL-DTL-38999 Series III Type TVS Connector Plug with Solder Cup Contacts

D38999 SERIES III TYPE TVS PLUG WITH SOLDER CUP CONTACTS

How To Order									
Sample Part Number	242-383	P	-XXXX	NF	19-11	P	S	N	N
TVS Connector	MIL-DTL-38999 Series III								
Shell Style	P = Plug								
Diode Net List	Assigned by Glenair. See Table V								
Material and Finish	See Table II								
Insert Arrangement	IAW MIL-STD-1560								
Contact Gender	P = Pin S = Socket								
Termination	S = Solder Cup								
Flange Mounting Style	N = Not Applicable								
Alternate Key Position	A, B, C, D, E, N = Normal, U = Universal (Do not mate Universal with Universal receptacle)								

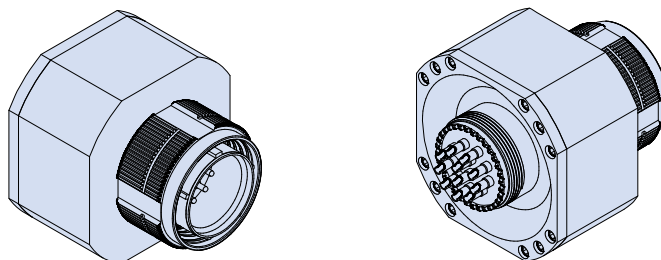

Notes

- Materials/Finishes: Shell Housing & Coupling Nut: See Table II
Ground Spring: Beryllium Copper Alloy/Electroless Nickel
Insulators: High grade rigid dielectric
Seals: Fluorosilicone
Contacts: Copper Alloy/Gold over Nickel per ASTM B 488
- Assembly to be identified with Glenair's name, part number, and date code - space permitting.
- Insert Arrangement in accordance with MIL-STD-1560. (Arrangement shown for reference only)
- Electrical Performance: Specific diode voltage code options per Table III. Diode wattage based on 10 x 1000 uS peak pulse power waveform.
Clamping Time: Less than 1 picosecond, 0V to min. breakdown.
- Glenair will assign a diode net list code and provide a separate net list drawing containing specific electrical requirements. Fill out applicable columns of Table V and return.
- Consult factory for low capacitance, ground requirements, power ratings above 5000W, special test requirements, or other modifications.
- Operating temperature: -55°C to +150°C

Dimensions in inches (millimeters) and are subject to change without notice.

242-383P
MIL-DTL-38999 Series III Type TVS Connector
Plug with Solder Cup Contacts

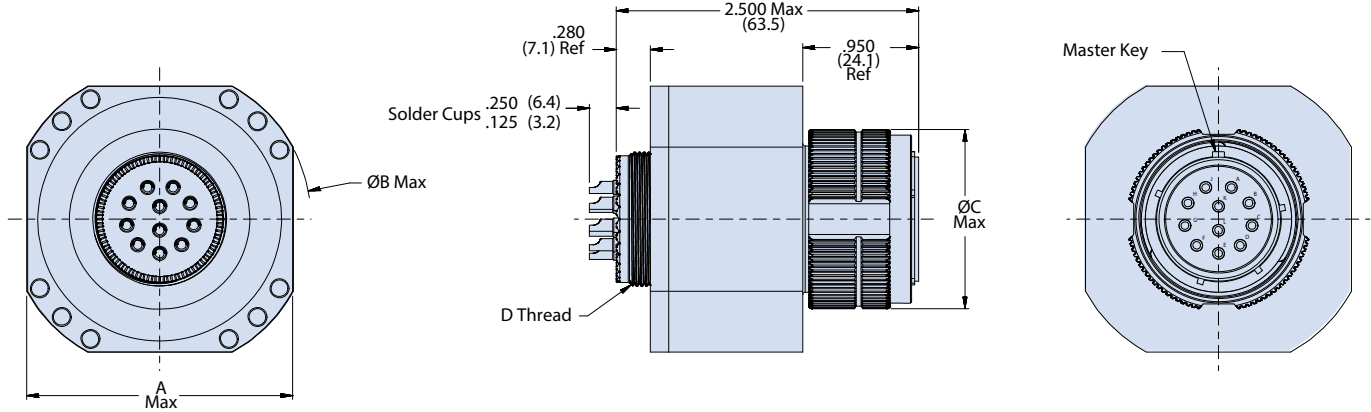

Table I: Dimensions

Shell Size	A Max	ØB Max	ØC Max	D Thread
9	1.000 (25.4)	1.300 (33.0)	.858 (21.8)	M12 X 1.0-6g 0.100R
11	1.400 (35.6)	1.700 (43.2)	.984 (25.0)	M15 X 1.0-6g 0.100R
13	1.700 (43.2)	2.000 (50.8)	1.157 (29.4)	M18 X 1.0-6g 0.100R
15	1.700 (43.2)	2.000 (50.8)	1.280 (32.5)	M22 X 1.0-6g 0.100R
17	2.000 (50.8)	2.300 (58.4)	1.406 (35.7)	M25 X 1.0-6g 0.100R
19	2.200 (55.9)	2.500 (63.5)	1.516 (38.5)	M28 X 1.0-6g 0.100R
21	2.300 (58.4)	2.600 (66.0)	1.642 (41.7)	M31 X 1.0-6g 0.100R
23	2.600 (66.0)	2.900 (73.7)	1.768 (44.9)	M34 X 1.0-6g 0.100R
25	2.900 (73.7)	3.200 (81.3)	1.890 (48.0)	M37 X 1.0-6g 0.100R

Table II: Material and Finish

Sym	Material	Finish Description
ME	Aluminum	Electroless Nickel
MT		Ni-PTFE 1000 Hour Grey™ Nickel Fluorocarbon Polymer
NF		Cadmium O.D. Over Electroless Nickel
ZN		Zinc-Nickel, Olive Drab
ZNU		Zinc Nickel, Black
ZR		Zinc Nickel, Black - RoHS
ZL	Stainless Steel	Electro-Deposited Nickel

Dimensions in inches (millimeters) and are subject to change without notice.



242-383S

MIL-DTL-38999 Series III Type TVS Connector Jam Nut Receptacle with Crimp Contacts

D38999 SERIES III TYPE TVS JAM NUT RECEPTACLE WITH CRIMP CONTACTS

How To Order	
Sample Part Number	242-383 S -XXXX NF 19-11 P C N N
TVS Connector	MIL-DTL-38999 Series III
Shell Style	S = Jam Nut Receptacle
Diode Net List	Assigned by Glenair. See Table V
Material and Finish	See Table II
Insert Arrangement	IAW MIL-STD-1560
Contact Gender	P = Pin S = Socket
Termination	C = Crimp
Flange Mounting Style	N = Not Applicable
Alternate Key Position	A, B, C, D, E, N = Normal, U = Universal (Do not mate Universal with Universal receptacle)

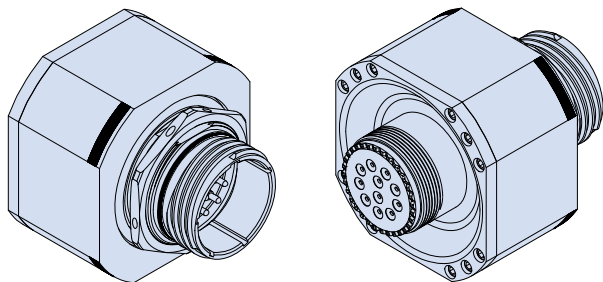

Table II: Material and Finish

Sym	Material	Finish Description
ME	Aluminum	Electroless Nickel
MT		Ni-PTFE 1000 Hour Grey™ Nickel Fluorocarbon Polymer
NF		Cadmium O.D. Over Electroless Nickel
ZN		Zinc-Nickel, Olive Drab
ZNU		Zinc Nickel, Black
ZR		Zinc Nickel, Black - RoHS
ZL	Stainless Steel	Electro-Deposited Nickel

Notes

- Materials/Finishes: Shell Housing & Jam Nut: See Table II
Ground Spring: Beryllium Copper Alloy/Electroless Nickel
Insulators: High grade rigid dielectric
Seals: Fluorosilicone
Contacts: Copper Alloy/Gold over Nickel per ASTM B 488
- Assembly to be identified with Glenair's name, part number, and date code - space permitting.
- Insert Arrangement in accordance with MIL-STD-1560.
(Arrangement shown for reference only)
- Electrical Performance: Specific diode voltage code options per Table III. Diode wattage based on 10 x 1000 uS peak pulse power waveform.

Clamping Time: Less than 1 picosecond, 0V to min. breakdown.

- Glenair will assign a diode net list code and provide a separate net list drawing containing specific electrical requirements. Fill out applicable columns of Table V and return.
- Consult factory for low capacitance, ground requirements, power ratings above 5000W, special test requirements, or other modifications.
- Operating temperature: -55°C to +150°C
- Crimp removable contacts to conform to M39029/57-359 Size #12, M39029/57-358 Size #16, M39029/57-357 Size #20, and M39029/57-354 Size #22D (supplied loose)

Dimensions in inches (millimeters) and are subject to change without notice.

242-383S
MIL-DTL-38999 Series III Type TVS Connector
Jam Nut Receptacle with Crimp Contacts

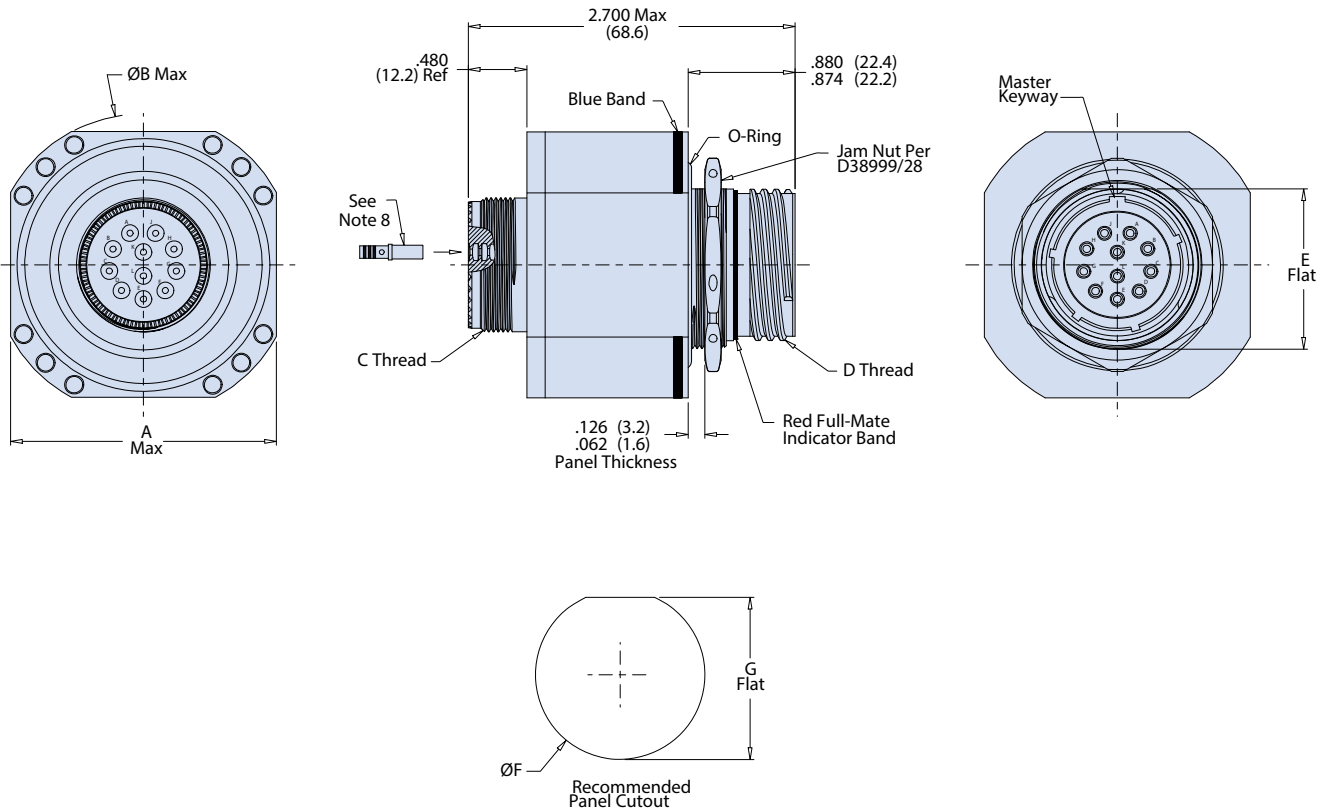

Table I: Dimensions

Shell Size	A Max	ØB Max	C Thread	D Thread	E Flat $\pm .005 (\pm .013)$	Ø F $\pm .005 (\pm .013)$	G Flat $\pm .005 (\pm .013)$
9	1.000 (25.4)	1.300 (33.0)	M12 X 1.0-6g 0.100R	.6250-.1P-.3L-TS-2A	.650 (16.5)	.705 (17.9)	.665 (16.9)
11	1.400 (35.6)	1.700 (43.2)	M15 X 1.0-6g 0.100R	.7500-.1P-.3L-TS-2A	.750 (19.1)	.830 (21.1)	.766 (19.5)
13	1.700 (43.2)	2.000 (50.8)	M18 X 1.0-6g 0.100R	.8750-.1P-.3L-TS-2A	.937 (23.8)	1.015 (25.8)	.950 (24.1)
15	1.700 (43.2)	2.000 (50.8)	M22 X 1.0-6g 0.100R	1.0000-.1P-.3L-TS-2A	1.063 (27.0)	1.140 (29.0)	1.080 (27.4)
17	2.000 (50.8)	2.300 (58.4)	M25 X 1.0-6g 0.100R	1.1875-.1P-.3L-TS-2A	1.186 (30.1)	1.265 (32.1)	1.205 (30.6)
19	2.200 (55.9)	2.500 (63.5)	M28 X 1.0-6g 0.100R	1.2500-.1P-.3L-TS-2A	1.311 (33.3)	1.390 (35.3)	1.330 (33.8)
21	2.300 (58.4)	2.600 (66.0)	M31 X 1.0-6g 0.100R	1.3750-.1P-.3L-TS-2A	1.436 (36.5)	1.515 (38.5)	1.455 (37.0)
23	2.600 (66.0)	2.900 (73.7)	M34 X 1.0-6g 0.100R	1.5000-.1P-.3L-TS-2A	1.561 (39.6)	1.640 (41.7)	1.580 (40.1)
25	2.900 (73.7)	3.200 (81.3)	M37 X 1.0-6g 0.100R	1.6250-.1P-.3L-TS-2A	1.686 (42.8)	1.765 (44.8)	1.705 (43.3)

Dimensions in inches (millimeters) and are subject to change without notice.



244-001

MIL-DTL-38999 Series III Type TVS Connector Jam Nut Receptacle with RJ45 Jack to Rear Solder Cup or PC Tail Termination and Standoffs

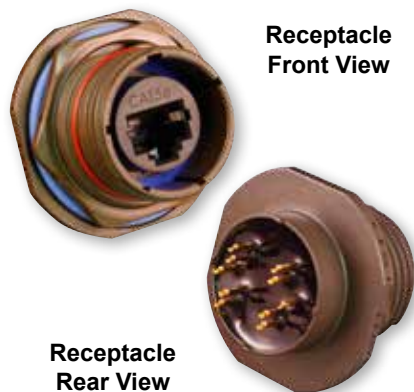

Receptacle
Front View

Receptacle
Rear View

Materials and Finishes¹

NF	Cadmium olive drab
ME	Electroless nickel
MT	Nickel PTFE

NOTES

1. See Section A for alternate key positions, panel cutout dimensions and complete finish options

All external dimensions, features, etc. compliant with D38999/20, /24, &/26. Consult factory for additional information.

How to Order

Sample Part Number	244-001	NF	19	P	G	N	1
Basic Number	244-001						
Finish ¹	See Material & Finish Table						
Shell Size	17 or 19						
Termination	P = PC tail S = Solder cup						
Insert-to-Shell Grounding	G = Shielded and grounded to shell						
Alternate Key Position ¹	Per MIL-DTL-38999 A, B, C, D, E, N = Normal ²						
RJ45 Orientation	1, 2, 3, or 4						

RJ45 ORIENTATION CODE AND PCB LAYOUT (PCB LAYOUT FOR PC TAIL VERSION)

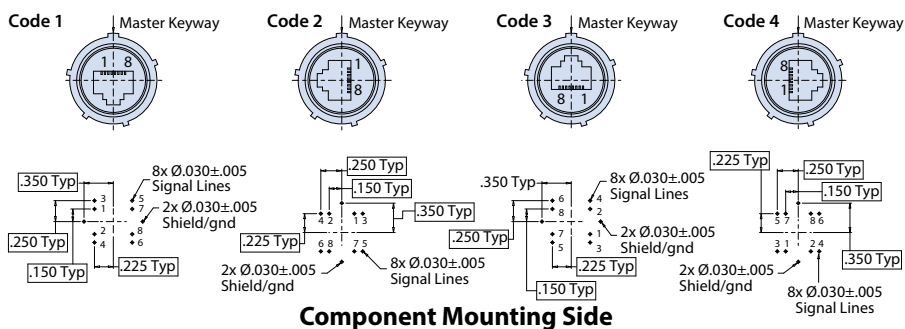

Jam Nut Dimensions

Shell Size	A Thread	B Thread	C		D Sq.		Ø E		Ø F		G Flat	
			in	mm	in	mm	in	mm	in	mm	in	mm
17	1.1875-.1P-.3L-TS-2A	M32 x 1.0-6g 0.100R	.122	3.10	1.642	41.71	1.764	44.81	1.270	32.56	1.210	30.73
			.083	2.11	1.610	40.89	1.740	44.20	1.260	32.00	1.200	30.48
19	1.2500-.1P-.3L-TS-2A	M35 x 1.0-6g 0.100R	.154	3.91	1.827	46.41	1.949	49.50	1.395	35.43	1.335	33.91
			.114	2.90	1.795	45.59	1.925	48.90	1.385	35.18	1.325	33.66

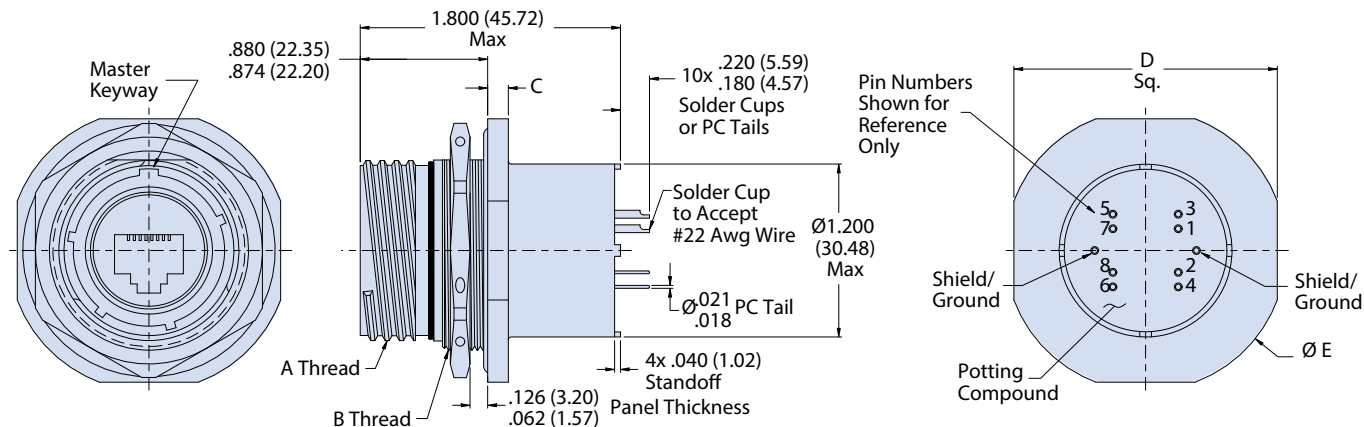

Dimensions in inches (millimeters) and are subject to change without notice.

244-002

MIL-DTL-38999 Series III Type TVS Connector
Wall Mount Receptacle with RJ45 Jack To Rear Solder Cup or PC Tail
Termination and Standoffs



TVS Connectors



How to Order	
Sample Part Number	244-002 NF 19 P G N 1
Basic Number	244-002
Finish ¹	See Material & Finish Table
Shell Size ¹	17 or 19
Termination	P = PC tail S = Solder cup
Insert-to-Shell Grounding	G = Shielded and grounded to shell
Alternate Key Position ¹	Per MIL-DTL-38999 A, B, C, D, E, N = Normal
RJ45 Orientation	1, 2, 3, or 4

Materials and Finishes ¹	
NF	Cadmium olive drab
ME	Electroless nickel
MT	Nickel PTFE

NOTES

- See Section A for alternate key positions, panel cutout dimensions and complete finish options

All external dimensions, features, etc. compliant with D38999/20, /24, &/26. Consult factory for additional information.

RJ45 ORIENTATION CODE AND PCB LAYOUT (PCB LAYOUT FOR PC TAIL VERSION)

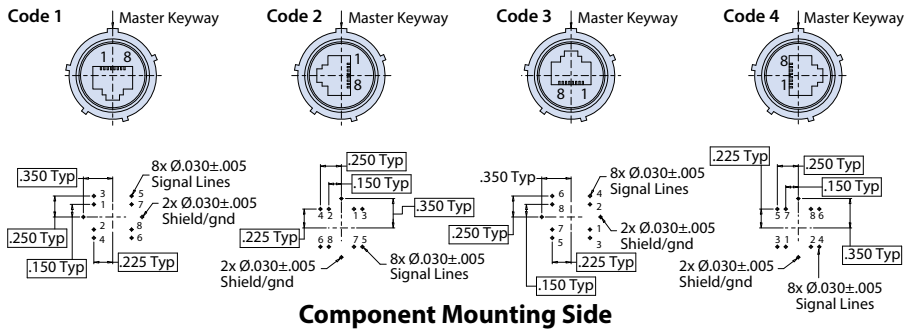

Component Mounting Side

Jam Nut Dimensions									
Shell Size	A Thread	B Sq.		C Bsc		Ø D Min.		E Bsc	
		in	mm	in	mm	in	mm	in	mm
17	1.1875-1P-.3L-TS-2A	1.323	33.60	1.062	26.97	1.219	30.96	1.062	26.97
		1.299	32.99						
19	1.2500-1P-.3L-TS-2A	1.449	36.80	1.156	29.36	1.297	32.94	1.156	29.36
		1.425	36.195						

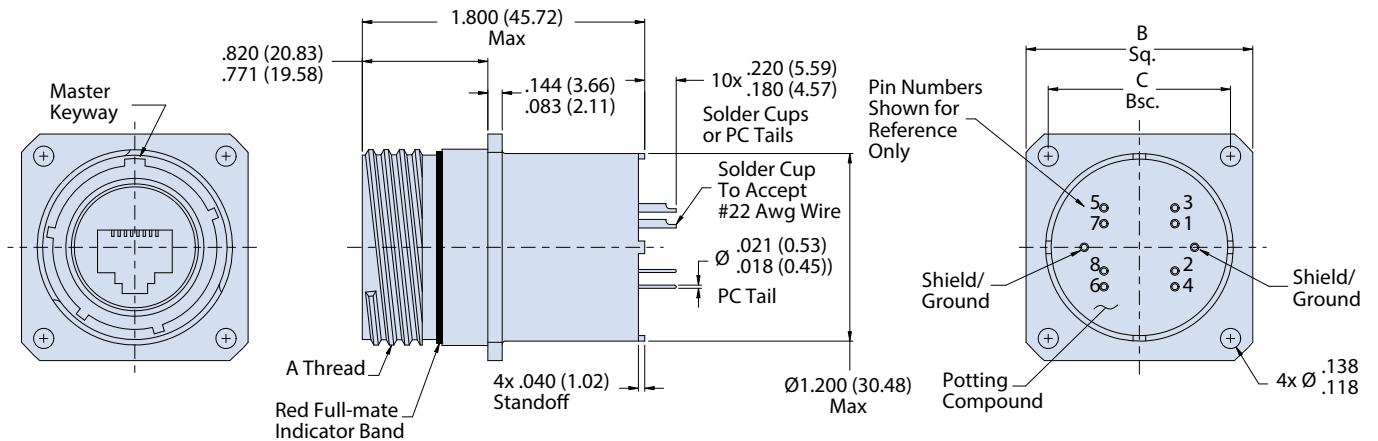

Dimensions in inches (millimeters) and are subject to change without notice.



244-003

MIL-DTL-38999 Series III Type TVS Connector Jam Nut Receptacle with RJ45 Jack To Rear Solder Cup or PC Tail Termination and Accessory Threads



Materials and Finishes¹

NF	Cadmium olive drab
ME	Electroless nickel
MT	Nickel PTFE

NOTES

- See Section A for alternate key positions, panel cutout dimensions and complete finish options

All external dimensions, features, etc. compliant with D38999/20, /24, &/26. Consult factory for additional information.

How to Order

Sample Part Number	244-003	NF	19	P	G	N	1
Basic Number	244-003						
Finish¹	See Material & Finish Table						
Shell Size	17 or 19						
Termination	P = PC tail S = Solder cup						
Insert-to-Shell Grounding	G = Shielded and grounded to shell						
Alternate Key Position¹	Per MIL-DTL-38999 A, B, C, D, E, N = Normal						
RJ45 Orientation	1, 2, 3, or 4						

RJ45 ORIENTATION CODE AND PCB LAYOUT (PCB LAYOUT FOR PC TAIL VERSION)

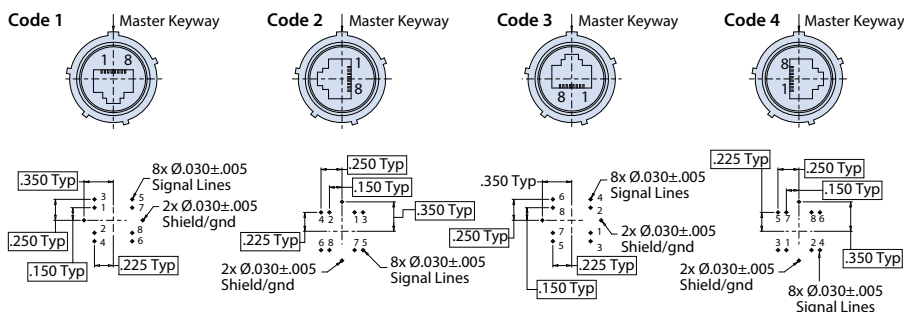

Component Mounting Side

Jam Nut Dimensions

Shell Size	A Thread	B Thread	C		D Sq.		$\varnothing E$		$\varnothing F$		G Flat	
			in	mm	in	mm	in	mm	in	mm	in	mm
17	1.1875-.1P-.3L-TS-2A	M32 x 1.0-6g 0.100R	.122	3.10	1.642	41.71	1.764	44.81	1.270	32.26	1.210	30.73
			.083	2.11	1.610	40.89	1.740	44.17	1.260	32.00	1.200	30.48
19	1.2500-.1P-.3L-TS-2A	M35 x 1.0-6g 0.100R	.154	3.91	1.827	46.41	1.949	49.50	1.395	35.43	1.35	33.91
			.114	2.90	1.795	45.59	1.925	48.90	1.385	35.18	1.325	33.66

JAM-NUT RECEPTACLE WITH ACCESSORY THREADS

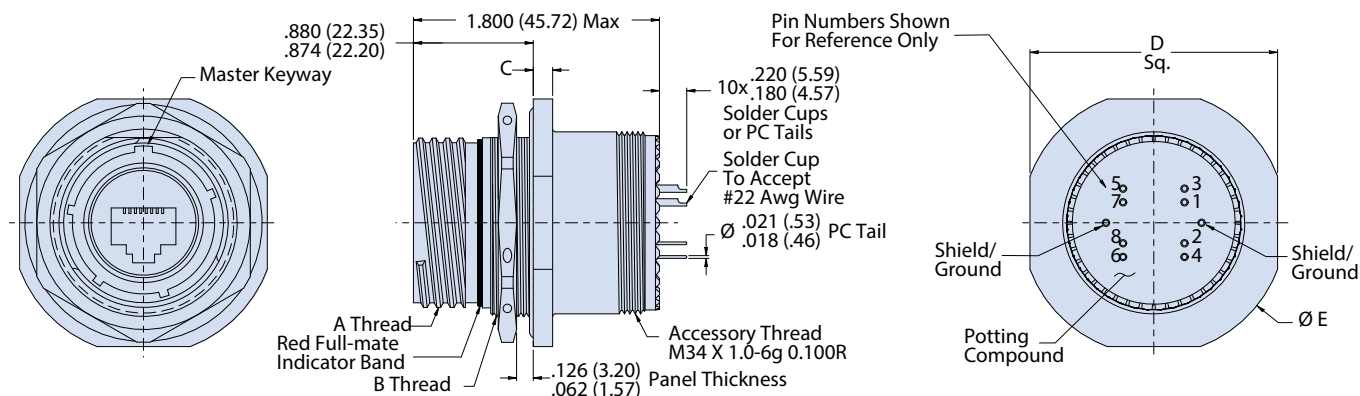

244-004

MIL-DTL-38999 Series III Type TVS Connector
Rear Panel Mount Receptacle with RJ45 Jack to Rear Solder Cup or
PC Tail Termination and Accessory Threads



TVS Connectors



How to Order	
Sample Part Number	244-004 NF 19 P G N 1
Basic Number	244-004
Finish ¹	See Material & Finish Table
Shell Size	17 or 19
Termination	P = PC tail S = Solder cup
Insert-to-Shell Grounding	G = Shielded and grounded to shell
Alternate Key Position	Per MIL-DTL-38999 A, B, C, D, E, N = Normal
RJ45 Orientation	1, 2, 3, or 4

Materials and Finishes ¹	
NF	Cadmium olive drab
ME	Electroless nickel
MT	Nickel PTFE

NOTES

- See Section A for alternate key positions, panel cutout dimensions and complete finish options

All external dimensions, features, etc. compliant with D38999/20, /24, &/26. Consult factory for additional information.

RJ45 ORIENTATION CODE AND PCB LAYOUT (PCB LAYOUT FOR PC TAIL VERSION)

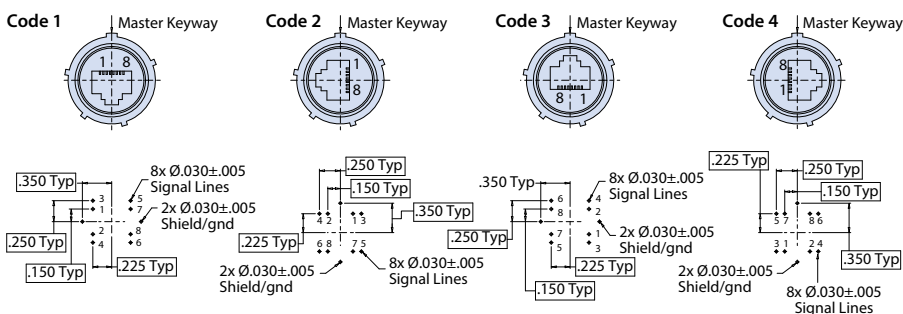

Component Mounting Side

		Jam Nut Dimensions							
Shell Size	A Thread	B Sq.		C Bsc		Ø D Min		E Bsc	
		in	mm	in	mm	in	mm	in	mm
17	1.1875-.1P-.3L-TS-2A	1.323 1.299	33.60 32.99	1.062	26.97	1.219	30.96	1.062	26.97
19	1.2500-.1P-.3L-TS-2A	1.449 1.425	36.80 36.195	1.156	29.36	1.297	32.94	1.156	29.36

REAR PANEL MOUNT RECEPTACLE WITH ACCESSORY THREADS

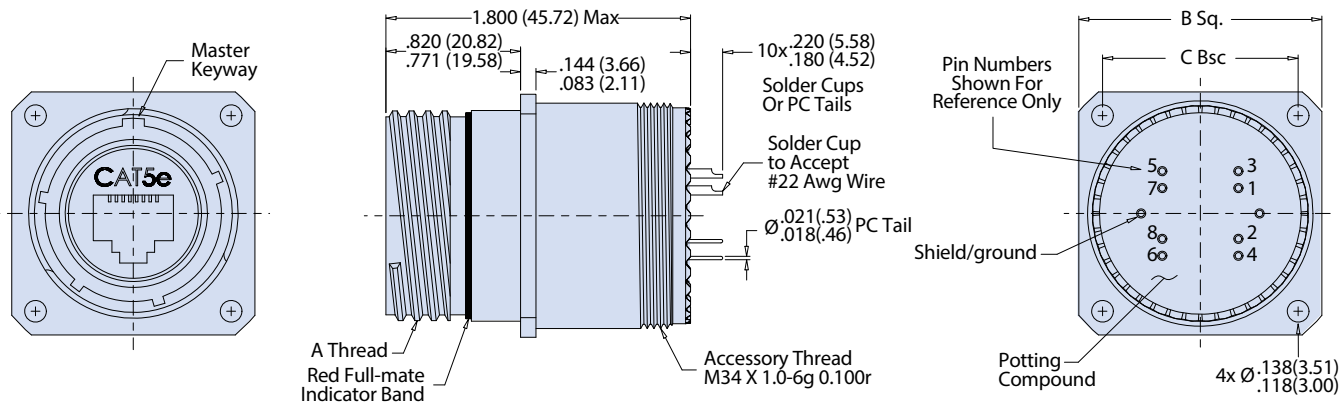

Dimensions in inches (millimeters) and are subject to change without notice.



MIL-DTL-38999 Series III Type TVS Connectors TVS Selection Chart

Table III: TVS Selection Chart

Diode Voltage Code	Reverse Standoff Voltage (V)	Breakdown Voltage (V)		Max Reverse Leakage (Ua)			Test Current (MA)	Maximum Clamping Voltage (V)	Diode Availability		
		Min	Max	1,500W	3,000W	5,000W			1,500W	3,000W	5,000W
5.0	5.0	6.40	7.00	800	800	N/A	10	9.2	X	X	
6.0	6.0	6.67	7.37	800	800	N/A	10	10.3	X	X	
6.5	6.5	7.22	7.98	500	500	N/A	10	11.2	X	X	
7.0	7.0	7.78	8.60	200	200	N/A	10	12.0	X	X	
7.5	7.5	8.33	9.21	100	100	N/A	1	12.9	X	X	
8.0	8.0	8.89	9.83	50	50	N/A	1	13.6	X	X	
8.5	8.5	9.44	10.40	20	20	N/A	1	14.4	X	X	
9.0	9.0	10.00	11.10	10	10	N/A	1	15.4	X	X	
10	10.0	11.10	12.30	5	5	N/A	1	17.0	X	X	
11	11.0	12.20	13.50	1	2	N/A	1	18.2	X	X	
12	12.0	13.30	14.70	1	2	800	1*	19.9	X	X	X
13	13.0	14.40	15.90	1	2	500	1*	21.5	X	X	X
14	14.0	15.60	17.20	1	2	200	1*	23.2	X	X	X
15	15.0	16.70	18.50	1	2	100	1	24.4	X	X	X
16	16.0	17.80	19.70	1	2	50	1	26.0	X	X	X
17	17.0	18.90	20.90	1	2	20	1	27.6	X	X	X
18	18.0	20.00	22.10	1	2	10	1	29.2	X	X	X
20	20.0	22.20	24.50	1	2	5	1	32.4	X	X	X
22	22.0	24.40	26.90	1	2	5	1	35.5	X	X	X
24	24.0	26.70	29.50	1	2	5	1	38.9	X	X	X
26	26.0	28.90	31.90	1	2	5	1	42.1	X	X	X
28	28.0	31.10	34.40	1	2	5	1	45.4	X	X	X
30	30.0	33.30	36.80	1	2	5	1	48.4	X	X	X
33	33.0	36.70	40.60	1	2	5	1	53.3	X	X	X
36	36.0	40.00	44.20	1	2	5	1	58.1	X	X	X
40	40.0	44.40	49.10	1	2	5	1	64.5	X	X	X
43	43.0	47.80	52.80	1	2	5	1	69.4	X	X	X
45	45.0	50.00	55.30	1	2	5	1	72.7	X	X	X
48	48.0	53.30	58.90	1	2	5	1	77.4	X	X	X
51	51.0	56.70	62.70	1	2	5	1	82.4	X	X	X
54	54.0	60.00	66.30	1	2	5	1	87.1	X	X	X
58	58.0	64.40	71.20	1	2	5	1	93.6	X	X	X
60	60.0	66.70	73.70	1	2	5	1	96.8	X	X	X
64	64.0	71.10	78.60	1	2	5	1	103.0	X	X	X
70	70.0	77.80	86.00	1	2	5	1	113.0	X	X	X
75	75.0	83.30	92.10	1	2	5	1	121.0	X	X	X
78	78.0	86.70	95.80	1	2	5	1	126.0	X	X	X
85	85.0	94.40	104.00	1	2	5	1	137.0	X	X	X
90	90.0	100.00	111.00	1	2	5	1	146.0	X	X	X
100	100.0	111.00	123.00	1	2	5	1	162.0	X	X	X
110	110.0	122.00	135.00	1	2	5	1	177.0	X	X	X
120	120.0	133.00	147.00	1	2	5	1	193.0	X	X	X
130	130.0	144.00	159.00	1	2	5	1	209.0	X	X	X
150	150.0	167.00	185.00	1	2	5	1	243.0	X	X	X
160	160.0	178.00	197.00	1	2	5	1	259.0	X	X	X
170	170.0	189.00	209.00	1	2	5	1	275.0	X	X	X
180	180.0	201.00	222.00	1	N/A	N/A	1	292.0	X		
200	200.0	224.00	247.00	1	N/A	N/A	1	324.0	X		
220	220.0	246.00	272.00	1	N/A	N/A	1	356.0	X		
250	250.0	279.00	309.00	1	N/A	N/A	1	405.0	X		
300	300.0	335.00	371.00	1	N/A	N/A	1	486.0	X		
350	350.0	391.00	432.00	1	N/A	N/A	1	567.0	X		
400	400.0	447.00	494.00	1	N/A	N/A	1	648.0	X		
440	440.0	492.00	543.00	1	N/A	N/A	1	713.0	X		

*Indicated test current is to be 10mA for 5,000W devices only.

Dimensions in inches (millimeters) and are subject to change without notice.

MIL-DTL-38999 Series III Type TVS Connectors

TVS Diode Power Selection Chart

Typical Junction Capacitance



Table IV: TVS Diode Power Selection Chart

RTCA DO-160 Waveform	Level	Open Circuit Voltage/ Short Circuit Voltage V/A	Reverse Standoff Voltage	Maximum Clamping Voltage	Recommended Minimum Diode Power (Watts)	
Waveform 3 Damped Sine 	1	100/4	5 to 60	9.2 to 96.8	600	
	2	250/10	5 to 150	9.2 to 243	600	
	3	600/24	5 to 170	9.2 to 275	600	
	4	1500/60	5 to 54	9.2 to 87.1	600	
			58 to 150	93.6 to 243	1,500	
			160 to 170	259 to 275	3,000	
	5	3200/128	5 to 22	9.2 to 35.5	600	
			24 to 60	38.9 to 96.8	1,500	
			64 to 130	103 to 209	3,000	
	Waveform 4 Double Exponential 6.4 X 69usec 	1	50/10	5 to 30	9.2 to 48.4	600
		2	125/25	5 to 75	9.2 to 121	600
		3	300/60	5 to 17	9.2 to 27.6	600
				18 to 26	29.2 to 42.1	3,000
				28 to 110	45.4 to 177	5,000
		4	750/150	120 to 170	193 to 275	15,000*
5 to 8.5				9.2 to 14.4	3,000	
9 to 60				15.4 to 96.8	5,000	
5		1600/320	64 to 170	103 to 275	15,000*	
			5 to 24	9.2 to 38.9	5,000	
			26 to 78	42.1 to 126	15,000*	
Waveform 5A Double Exponential 40 X 120usec 		1	50/50	5 to 30	9.2 to 48.4	1,500
		2	125/125	5 to 75	9.2 to 121	3,000
		3	300/300	5 to 15	9.2 to 24.4	3,000
				17 to 170	26.7 to 275	15,000*
	4	750/750	180	291	30,000*	
			17 to 22	26.7 to 35.5	15,000*	
	5	1600/1600	30 to 48	55.2 to 77.4	30,000*	
				N/A		

*Consult factory for Diode Power Ratings above 5,000W

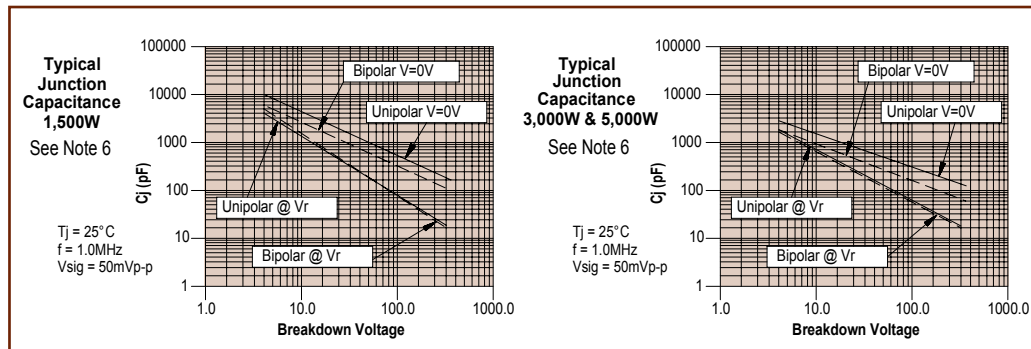

Dimensions in inches (millimeters) and are subject to change without notice.



MIL-DTL-38999 Series III Type TVS Connectors TVS Diode Requirement Form

Table V: TVS Diode Requirement Form (Fill out and return)

Connector Pin #		Diode Voltage Code 5.0 – 440	Diode Polarity Bipolar / Unipolar	Diode Wattage 1,500W / 3,000W / 5,000W	Connector Pin #		Diode Voltage Code 5.0 – 440
1	A				44	w	
2	B				45	x	
3	C				46	y	
4	D				47	z	
5	E				48	AA	
6	F				49	BB	
7	G				50	CC	
8	H				51	DD	
9	J				52	EE	
10	K				53	FF	
11	L				54	GG	
12	M				55	HH	
13	N				56	JJ	
14	P				57	KK	
15	R				58	LL	
16	S				59	MM	
17	T				60	NN	
18	U				61	PP	
19	V				62		
20	W				63		
21	X				64		
22	Y				65		
23	Z				66		
24	a				67		
25	b				68		
26	c				69		
27	d				70		
28	e				71		
29	f				72		
30	g				73		
31	h				74		
32	i				75		
33	j				76		
34	k				77		
35	m				78		
36	n				79		
37	p				80		
38	q				81		
39	r				82		
40	s				83		
41	t				84		
42	u				85		
43	v				86		

Note: Enter "No Diode" for unprotected lines

Dimensions in inches (millimeters) and are subject to change without notice.

**MIL-DTL-38999 Series III Type TVS Connectors
TVS Diode Requirement Form**



Diode Polarity Bipolar / Unipolar	Diode Wattage 1,500W / 3,000W / 5,000W	Connector Pin #	Diode Voltage Code 5.0 – 440	Diode Polarity Bipolar / Unipolar	Diode Wattage 1,500W / 3,000W / 5,000W
		87			
		88			
		89			
		90			
		91			
		92			
		93			
		94			
		95			
		96			
		97			
		98			
		99			
		100			
		101			
		102			
		103			
		104			
		105			
		106			
		107			
		108			
		109			
		110			
		111			
		112			
		113			
		114			
		115			
		116			
		117			
		118			
		119			
		120			
		121			
		122			
		123			
		124			
		125			
		126			
		127			
		128			



Dimensions in inches (millimeters) and are subject to change without notice.

SERIES 245

Mighty Mouse Breakout Board

Rugged, reliable performance for on-site testing



The Glenair small form-factor 245-805 Mighty Mouse Breakout Board allows fast and reliable monitoring / testing of Unit Under Test (UUT) circuits and contacts during operation. The breakout board, equipped with switch technology instead of fragile plastic jumpers, is inserted between the UUT and the interconnect cable assembly to facilitate accurate debugging of intermittent failures / abnormal transient signals. Each breakout board is supplied with a rugged overmolded cordset that ensures test board durability in both laboratory and on-site testing.

- Switches offer improved durability and reliability over plastic jumpers
- .080" test points
- Circuit board is secured in a metal shell for strength and stability
- Supplied with a cable assembly to facilitate on-site testing
- Available for the complete range of Series 805 Mighty Mouse insert arrangements

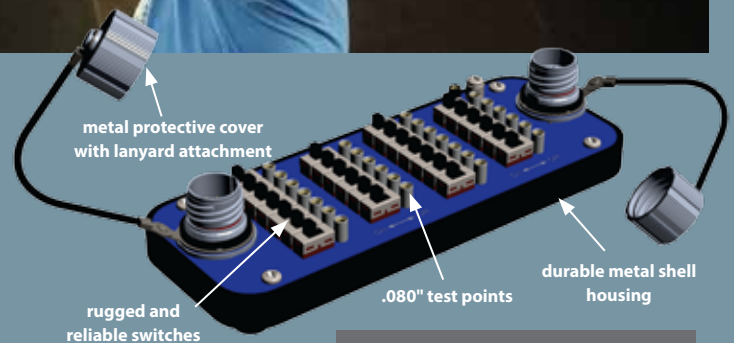

Glenair®

Glenair, Inc.
1211 Air Way
Glendale, CA
91201-2497
818-247-6000
sales@glenair.com
www.glenair.com

SERIES 245

Mighty Mouse Breakout Board

Rugged, reliable performance for on-site testing

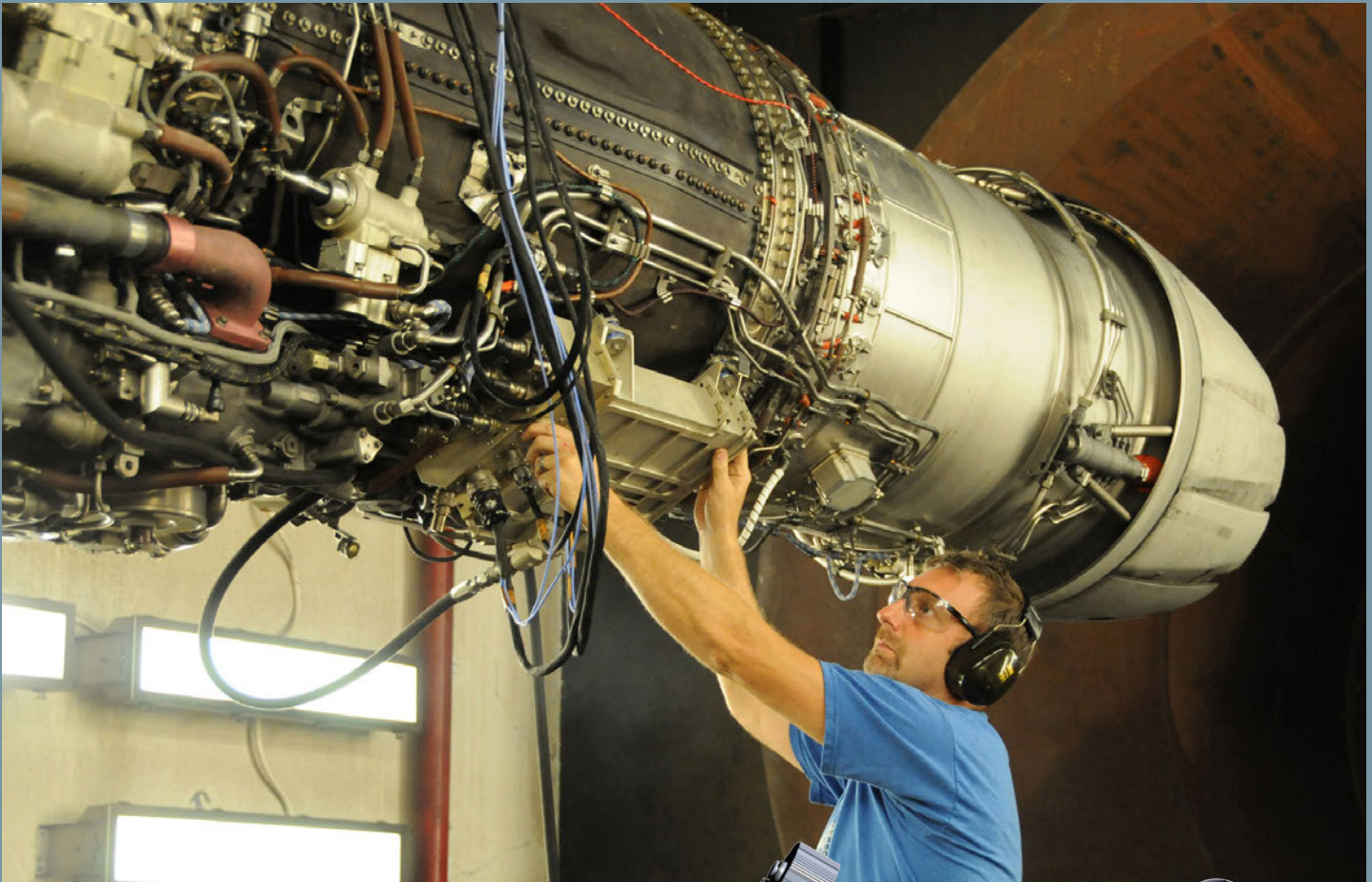

The Glenair small form-factor 245-805 Mighty Mouse Breakout Board allows fast and reliable monitoring / testing of Unit Under Test (UUT) circuits and contacts during operation. The breakout board, equipped with switch technology instead of fragile plastic jumpers, is inserted between the UUT and the interconnect cable assembly to facilitate accurate debugging of intermittent failures / abnormal transient signals. Each breakout board is supplied with a rugged overmolded cordset that ensures test board durability in both laboratory and on-site testing.

- Switches offer improved durability and reliability over plastic jumpers
- .080" test points
- Circuit board is secured in a metal shell for strength and stability
- Supplied with a cable assembly to facilitate on-site testing
- Available for the complete range of Series 805 Mighty Mouse insert arrangements

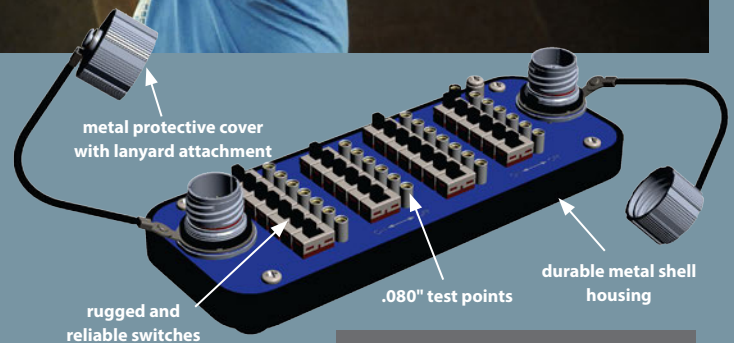

Glenair[®]

Glenair, Inc.
1211 Air Way
Glendale, CA
91201-2497
818-247-6000
sales@glenair.com
www.glenair.com

245-805 Mighty Mouse Breakout Board



How To Order					
Sample Part Number	245-805	-NF	12-26	A	-36
Breakout Board	Series 805 Mighty Mouse				
Material/Finish	See Table I				
Connector Insert Arrangement	See Table II				
Connector Key Position	A, B, C, D, E, F (A=Normal)				
Cordset Length	In inches (12 In. min.) Omit = No cordset				

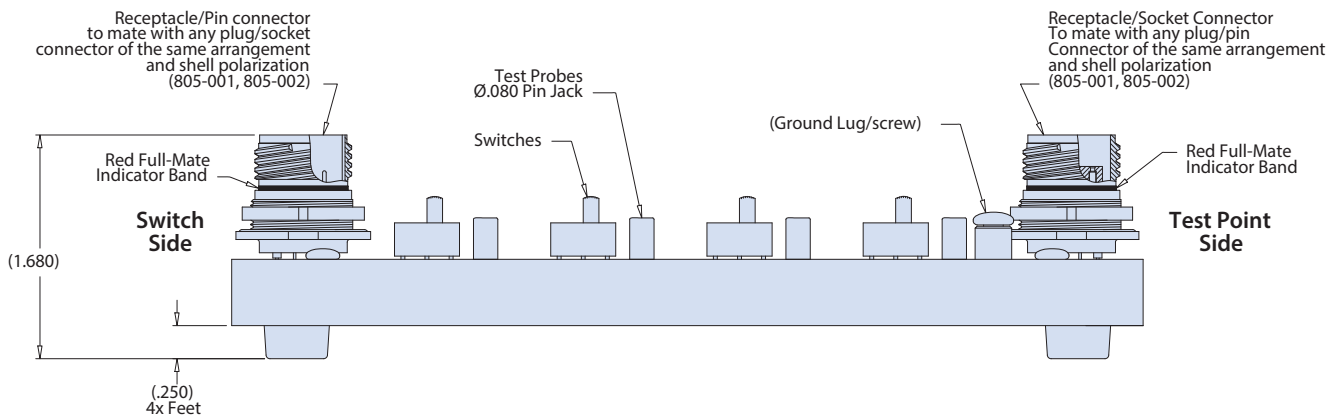
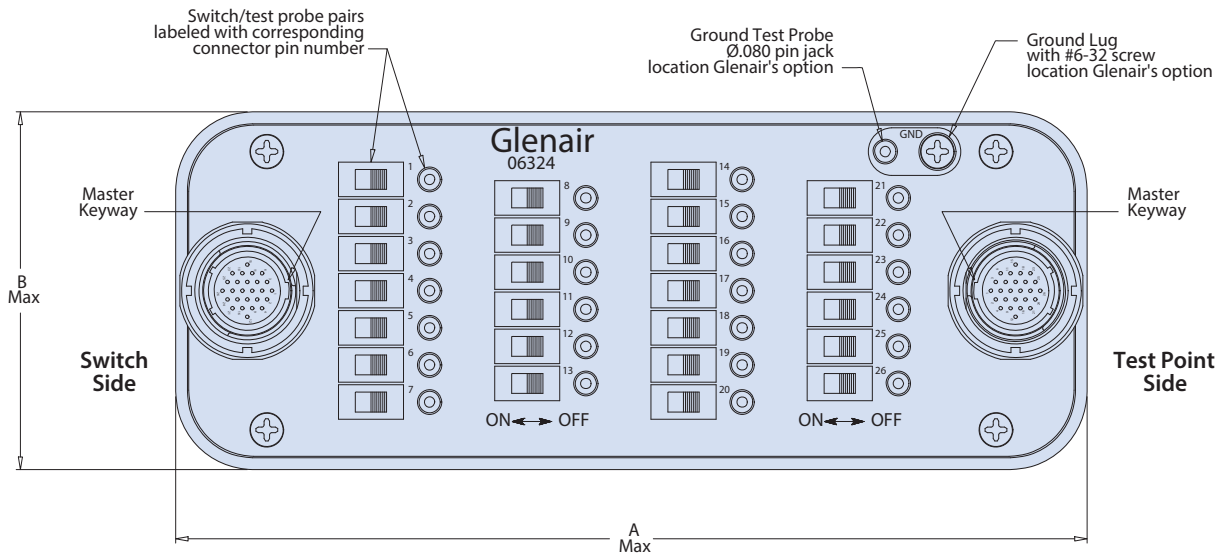

Dimensions in inches (millimeters) and are subject to change without notice.

© 2013 Glenair, Inc.

U.S. CAGE Code 06324

Printed in U.S.A.

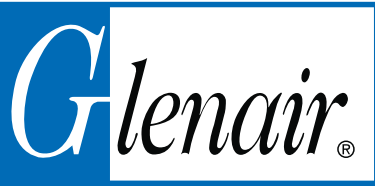

245-805 Mighty Mouse Breakout Board

Table I: Material/Finish

Class	Shell Material	Finish Description
M	Aluminum	Electroless Nickel
MT		Ni-PTFE 1000 Hour Grey
NF		Olive Drab Cadmium Over Electroless Nickel
ZN		Ninc-Nickel, Olive Drab
ZNU		Zinc-Nickel, Black
ZL	Stainless Steel	Electro-Deposited Nickel

Table III: Dimensions

Board Size	A Max		B Max		Max Trace Length (PCB)	
	In.	mm.	In.	mm.	In.	mm.
2	4.000	101.6	2.250	57.2	4.0	101.6
3	5.250	133.4	2.250	57.2	7.0	177.8
4	7.250	184.2	3.000	76.2	10.0	254.0
5	7.500	190.5	3.750	95.3	13.0	330.2
6	8.500	215.9	5.500	139.7	18.0	457.2
7	9.500	241.3	6.750	171.5	20.0	508.0

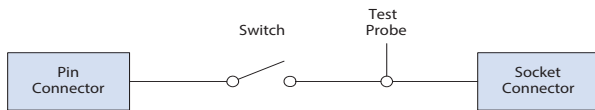
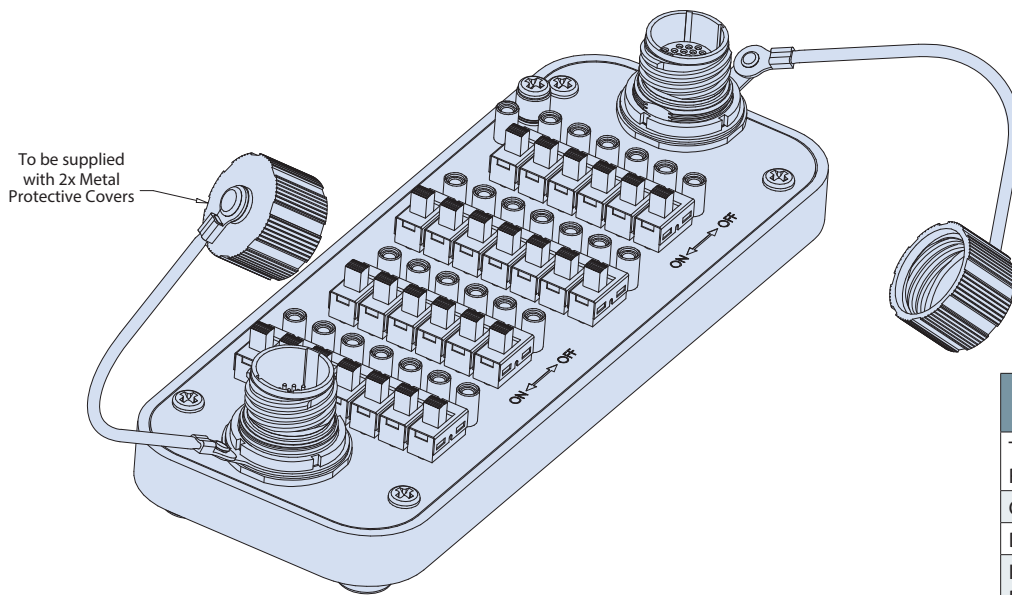
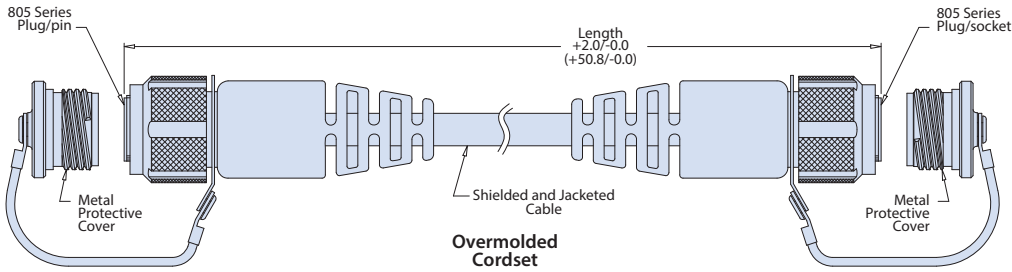

Table II: 805 Series Mighty Mouse Contact Arrangements

Contact Size	Contact Quantity					Insert Arrangement	Board Size
	#23	#20	#20HD	#16	#12		
Size #23 Contacts	4					8-4	2
	6					8-6	2
	7					8-7	2
	10					9-10	2
	13					10-13	2
	19					11-19	3
	26					12-26	4
	31					13-31	4
	37					15-37	4
	55					18-55	5
Size #20HD Contacts	85					19-85	6
	100					21-100	6
	130					23-130	7
			3			8-23	2
			5			9-25	2
			8			10-28	2
			10			11-210	2
			20			15-220	3
			35			18-235	4
			41			19-241	5
Size #16 Contacts					55	21-255	6
					69	23-269	6
				1		8-1	2
				2		10-2	2
				4		11-4	2
				5		12-5	2
				7		15-7	2
				12		18-12	3
				14		19-14	3
				19		21-19	4
Size #12 Contacts					22	23-22	4
					1	9-1	2
					2	12-2	2
					2	15-2	2
					3	15-3	2
					5	18-5	2
					7	19-7	2
					12	23-12	3
Mixed Size "Combo" Layouts	4	2				10-200	2
	8	2				11-201	2
	4			2		11-200	2
	8			2		12-202	2
	4				2	12-201	2
	6				2	15-200	2
	10				2	15-201	2
	12				1	12-200	2

Dimensions in inches (millimeters) and are subject to change without notice.

245-805 Mighty Mouse Breakout Board



Series 245 Breakout Board Performance Specifications	
Temperature Rating	-30°C to +85°
Current Rating	5A Max
DWV	300 VDC
Insulation Resistance	5 Gigohms Min @ 200 VDC
Note: Although the PCB traces and components used are capable of withstanding high voltage/current, use caution to avoid exposure to any lethal levels. Not intended for handheld use at voltages above 33 VRMS/70 VDC.	

Material/Finish

- Connector Seals - Fluorosilicone
- Connector Contacts - Copper Alloy/Gold Over Nickel per ASTM B488
- Housing - Aluminum Alloy/Black Anodized
- Circuit Board - FR4 Epoxy Glass/Gold or HASL Plated Solder Pads
- Test Probe Contact - Copper Alloy/Silver Plating
- Hardware - Stainless Steel/Passivated
- Feet - Thermoplastic 75 Durometer

Notes:

- Standard breakout boards do not contain current limiting or current protection devices. It is the user's responsibility to limit current. Consult factory with custom requirements, including TVS diode protection or in-line resistors.
- Optional cordset supplied standard with plug/plug configuration—pin contacts on one side and socket contacts on the other.

Dimensions in inches (millimeters) and are subject to change without notice.

SERIES 240

Conductive Gaskets and Accessories

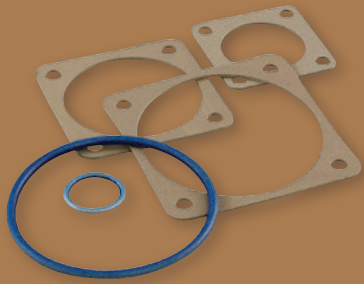

Key elements in every interconnect system designed for optimal EMC performance



Designers of interconnect cable systems have a responsibility to manage potential sources of electromagnetic interference. This includes shielding electronic boxes to prevent the emission of EMI from electronic system components, as well as shielding interconnect cabling to prevent interference from grounding to wire circuits. Key technologies in EMC design include conductive panel gaskets, connector o-rings, and conductive braided cable shielding. Backshells used as cable shield termination devices are also critical components in a well-designed interconnect system. Glenair is the world's largest manufacturer and supplier of EMC connector accessories, EMI/RFI braided shielding, and the assembly tools required for proper installation and use of these technologies. This section of the catalog introduces just a few of the more important accessory elements in systems designed for EMC. For information on other products of this type, please consult the factory or see www.glenair.com.



Glenair, Inc.
1211 Air Way
Glendale, CA
91201-2497
818-247-6000
sales@glenair.com
www.glenair.com

Product Selection Guide

249-001
Page L-2

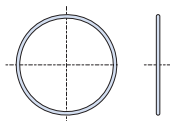

Conductive O-Ring for D38999 Jam Nut Receptacles

249-002
Page L-4

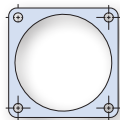

Conductive O-Ring for D38999 Wall Mount Receptacles

249-003
Page L-6

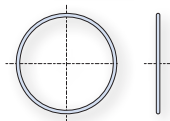

Conductive O-Ring for Mighty Mouse Jam Nut Receptacles

249-005
Page L-8

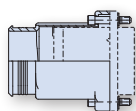

EMI/RFI Backshell for Micro-D Filter Connectors

249-006
Page L-9

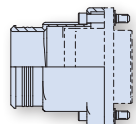

EMI/RFI Backshell for C-Filter Micro-D Connectors

249-033
Page L-10



Jackscrew/Jackpost Kit for Filter Micro-D Adapters

249-051
Page L-10



Jackscrew/Jackpost Kit for Filter D-Sub Adapters

179-045
Page L-11

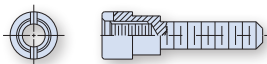

Jackpost Kit for Rear Panel Mount Micro-D Connectors

103-026, -027,
-031, -051
Page L-12



AmberStrand and ArmorLite Microfilament Composite Braid

107-098, 107-099
Page L-14

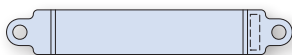

ArmorLite Single- and Dual-Layer Grounding Straps

103-026, -027,
-031, -051
Page L-16



Band-Master™ ATS Manual Tools and Bands

Dimensions in inches (millimeters) and are subject to change without notice.

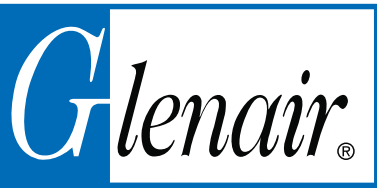

249-001
Conductive O-Ring
for D38999 Jam Nut Receptacles

CONDUCTIVE O-RING FOR D38999 JAM NUT RECEPTACLES

How To Order			
Sample Part Number	249-001	-09	-H
Conductive O-Ring	for D38999 Jam Nut Receptacles		
Dash No.	See Table I		
Material	See Table II		

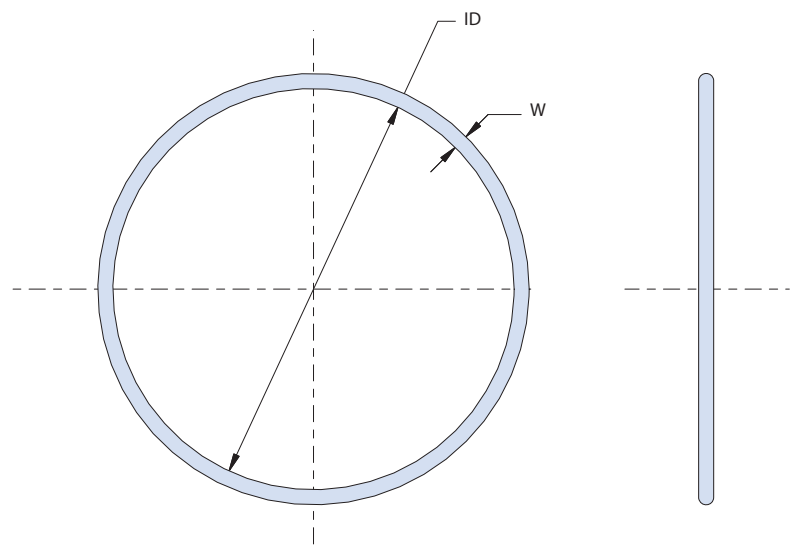

Notes

1. Parts of the same dash number to be packaged in bulk and identified by bag and tag.
2. Kits to be packaged and identified with Glenair name plus part number in large print.

Dimensions in inches (millimeters) and are subject to change without notice.

249-001
Conductive O-Ring
for D38999 Jam Nut Receptacles



Table I: Dash No.

Dash Number	O-Ring ID x W
-09	.801 x .070
-11	.989 x .070
-13	1.114 x .070
-15	1.239 x .070
-17	1.364 x .070
-19	1.487 x .103
-21	1.612 x .103
-23	1.737 x .103
-25	1.862 x .103
-KIT	2 each of dash no. -09 thru -25

Table II: Material

Designator	Material
B	Silver Plated Aluminum Filled Silicone per MIL-DTL-83528, Type "B" (CHO-SEAL 1285 or equivalent)
C	Passivated Silver Plated Aluminum Filled Fluorosilicone per MIL-DTL-83528, Type "D" (CHO-SEAL 1298 or equivalent)
E	Nickel Coated Graphite Filled EPDM (CHO-SEAL 6307 or equivalent)
H	Silver Plated Copper Filled Silicone per MIL-DTL-83528, Type "A" (CHO-SEAL 1215 or equivalent)
S	Nickel Coated Graphite Filled Silicone (CHO SEAL S6305 or equivalent)
L	Nickel Coated Graphite Filled Fluorosilicone (CHO-SEAL L6303 or equivalent)
Y	Nickel Plated Aluminum Filled Fluorosilicone (CHO-SEAL 6503 or equivalent)

Dimensions in inches (millimeters) and are subject to change without notice.



249-002
Conductive Gasket
for D38999 Wall Mount Receptacles

CONDUCTIVE GASKET FOR D38999 WALL MOUNT RECEPTACLES

How To Order			
Sample Part Number	249-002	-09	-H
Conductive Gasket	for D38999 Wall Mount Receptacles		
Dash No.	See Table I		
Material	See Table II		

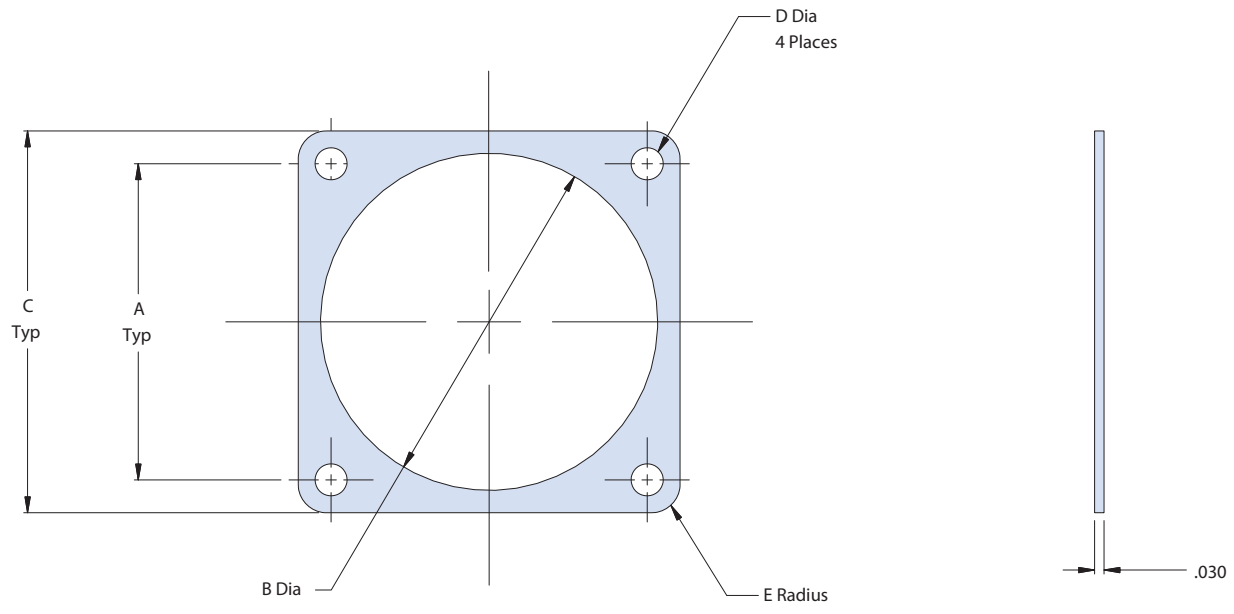

Notes

1. Parts of the same dash number to be packaged in bulk and identified by bag and tag.

Dimensions in inches (millimeters) and are subject to change without notice.

249-002
Conductive Gasket
for D38999 Wall Mount Receptacles



Table I: Dash No.					
Dash Number	A ± .005 (.13)	Ø B ± .007 (.18)	C ± .008 (.20)	Ø D ± .005 (.13)	E Radius ± .015 (.38)
-09	0.719 (18.3)	0.687 (17.4)	0.937 (23.8)	0.125 (3.2)	0.105 (2.7)
-11	0.812 (20.6)	0.772 (19.6)	1.031 (26.2)	0.125 (3.2)	0.105 (2.7)
-13	0.906 (23.0)	0.937 (23.8)	1.125 (28.6)	0.125 (3.2)	0.105 (2.7)
-15	0.969 (24.6)	1.063 (27.0)	1.250 (31.8)	0.125 (3.2)	0.135 (3.4)
-17	1.062 (27.0)	1.187 (30.1)	1.343 (34.1)	0.125 (3.2)	0.135 (3.4)
-19	1.156 (29.4)	1.312 (33.3)	1.467 (37.3)	0.125 (3.2)	0.135 (3.4)
-21	1.250 (31.8)	1.437 (36.5)	1.562 (39.7)	0.125 (3.2)	0.135 (3.4)
-23	1.375 (34.9)	1.562 (39.7)	1.703 (43.3)	0.152 (3.9)	0.135 (3.4)
-25	1.500 (38.1)	1.600 (40.6)	1.812 (46.0)	0.152 (3.9)	0.135 (3.4)

Table II: Material	
Designator	Material
C	Passivated Silver Plated Aluminum Filled Fluorosilicone per MIL-DTL-83528, Type "D" (CHO-SEAL 1298 or equivalent)
H	Silver Plated Copper Filled Silicone per MIL-DTL-83528, Type "A" (CHO-SEAL 1215 or equivalent)
E	Nickel Plated Graphite Filled EPDM (CHO-SEAL 6307 or equivalent)
F	Silver Plated Nickel Filled EPDM (CHO-SEAL 6435 or equivalent)



Dimensions in inches (millimeters) and are subject to change without notice.



249-003
Conductive O-Ring
for Mighty Mouse Jam Nut Receptacles

CONDUCTIVE O-RING FOR MIGHTY MOUSE JAM NUT RECEPTACLES

How To Order				
Sample Part Number	249-003	-801	-06	-B
Conductive O-Ring	for Mighty Mouse Jam Nut Receptacles			
Mighty Mouse Connector Series	-800, -801, -804, -805			
Shell Size	See Table I			
Material	See Table II			

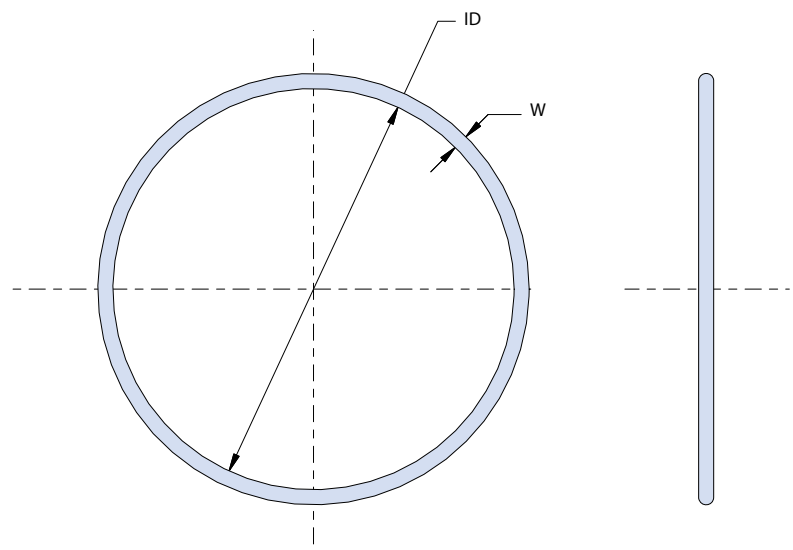

Notes

1. Parts to be packaged in bulk and identified by bag and tag.

Dimensions in inches (millimeters) and are subject to change without notice.

249-003
Conductive O-Ring
for Mighty Mouse Jam Nut Receptacles



Table I: Shell Size				
Shell Size	800 Series O-Ring ID x W	801 Series O-Ring ID x W	804 Series O-Ring ID x W	805 Series O-Ring ID x W
-5	.364 X .045	.394 X .047	.505 X .070	
-6	.426 X .050	.459 X .049	.525 X .071	
-7	.489 X .055	.578 X .040	.638 X .073	
-8	.588 X .051	.578 X .040	.688 X .070	.578 X .040
-9	.614 X .070	.650 X .045	.750 X .070	.709 X .045
-10	.709 X .079	.709 X .043	.813 X .063	.709 X .045
-11				.780 X .047
-12	.801 X .070		.943 X .070	.894 X .047
-13		.894 X .047		
-14	.926 X .070		1.061 X .073	
-15	.989 X .070		1.114 X .070	1.024 X .047
-16		1.086 X .040		
-17		1.142 X .043		
-18				1.201 X .047
-19				1.257 X .047
-21		1.417 X .047		
-23				1.530 X .047

Table II: Material	
Designator	Material
B	Silver Plated Aluminum Filled Silicone per MIL-DTL-83528, Type "B" (CHO-SEAL 1285 or equivalent)
C	Passivated Silver Plated Aluminum Filled Fluorosilicone per MIL-DTL-83528, Type "D" (CHO-SEAL 1298 or equivalent)
H	Silver Plated Copper Filled Silicone per MIL-DTL-83528, Type "A" (CHO-SEAL 1215 or equivalent)
X	Nickel Plated Aluminum Filled Silicone (Cho-Seal 6502 or equivalent)
Y	Nickel Plated Aluminum Filled fluorosilicone (Cho-Seal 6503 or equivalent)

Dimensions in inches (millimeters) and are subject to change without notice.

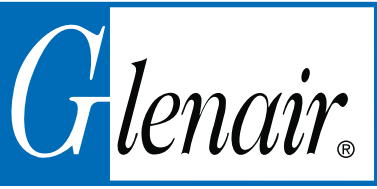

249-005
EMI/RFI Backshell
for Micro-D Filter Connectors

EMI/RFI BACKSHELL FOR MICRO-D FILTER CONNECTORS

How To Order					
Sample Part Number	249-005	M	25	H	M
EMI/RFI Backshell	for Micro-D Filter Connectors				
Finish	M = Electroless Nickel Z2 = Gold Plate				
Shell Size	(See Table I)				
Hardware Option	B = Slotted Head H = Hex Socket Head				
Band Option	M = Micro-Band Included N = No Band Supplied				

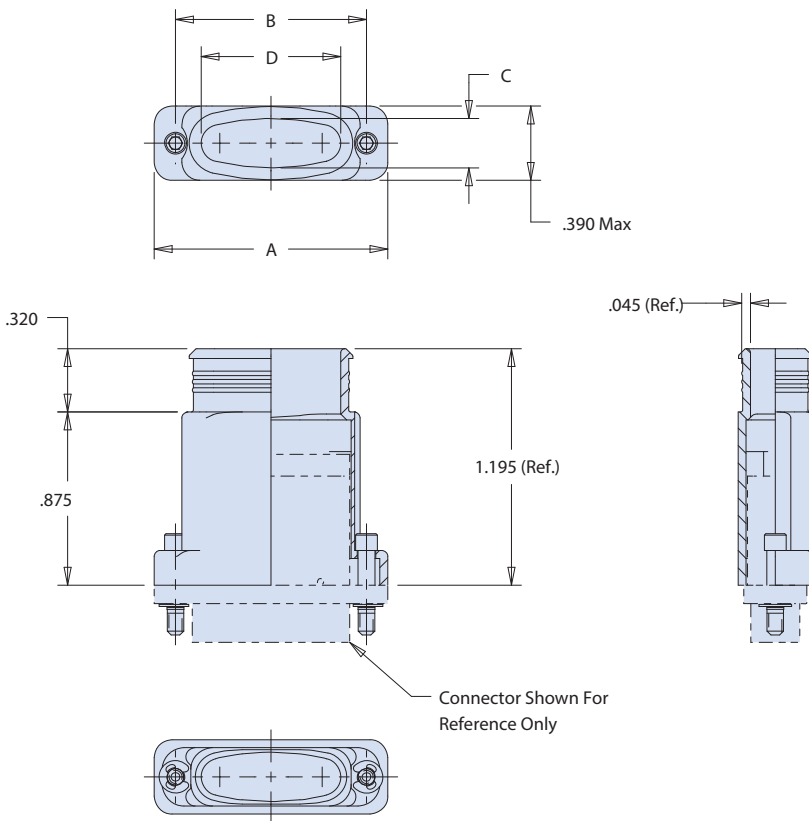

Table I: Shell Size/Dimensions					
Size	A Max	B	C	D	Dia / Sq. In.
09	0.785 (19.9)	0.565 (14.4)	0.180 (4.6)	0.180 (4.6)	0.171/0.023 (0.6/4.3)
15	0.935 (23.7)	0.715 (18.2)	0.230 (5.8)	0.230 (5.8)	0.216/0.037 (0.9/5.5)
21	1.085 (27.6)	0.865 (22.0)	0.220 (5.6)	0.380 (9.7)	0.257/0.052 (1.3/6.5)
25	1.185 (30.1)	0.965 (24.5)	0.220 (5.6)	0.480 (12.2)	0.276/0.060 (1.5/7.0)
31	1.335 (33.9)	1.115 (28.3)	0.220 (5.6)	0.630 (16.0)	0.306/0.074 (1.9/7.8)
37	1.485 (37.7)	1.265 (32.1)	0.220 (5.6)	0.780 (19.8)	0.367/0.106 (2.7/9.3)

Notes

1. Assembly identified with Glenair's name, P/N and date code, space permitting

Material/Finish

Backshell - Al Alloy
Hardware - 300 Series CRES/Passivated

Dimensions in inches (millimeters) and are subject to change without notice.

249-006
EMI/RFI Backshell
for C-Filter Micro-D Connectors



EMI/RFI BACKSHELL FOR C-FILTER MICRO-D FILTER CONNECTORS

How To Order					
Sample Part Number	249-006	M	25	H	M
EMI/RFI Backshell	for C-Filter Micro-D Filter Connectors				
Finish	M = Electroless Nickel Z2 = Gold Plate				
Shell Size	(See Table I)				
Hardware Option	B = Slotted Head H = Hex Socket Head				
Band Option	M = Micro-Band Included N = No Band Supplied				

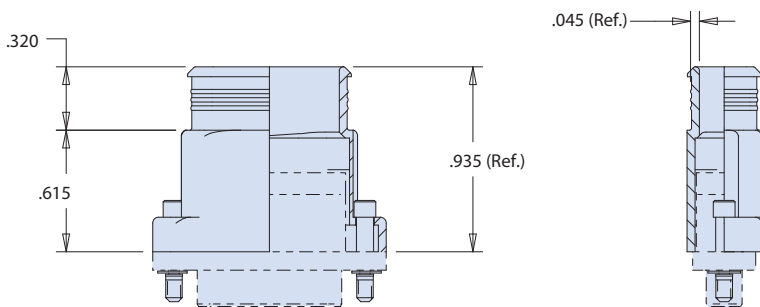
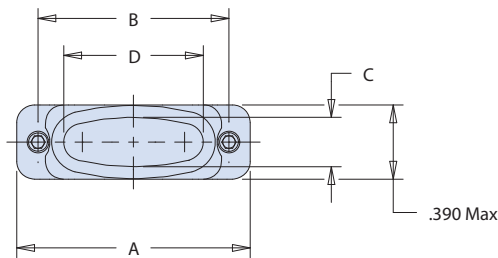

Connector Shown For Reference Only

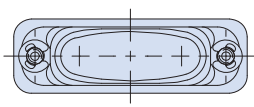

Table I: Shell Size/Dimensions					
Size	A Max	B	C	D	Dia / Sq. In.
09	0.785 (19.9)	0.565 (14.4)	0.180 (4.6)	0.180 (4.6)	0.171/0.023 (0.6/4.3)
15	0.935 (23.7)	0.715 (18.2)	0.230 (5.8)	0.230 (5.8)	0.216/0.037 (0.9/5.5)
21	1.085 (27.6)	0.865 (22.0)	0.220 (5.6)	0.380 (9.7)	0.257/0.052 (1.3/6.5)
25	1.185 (30.1)	0.965 (24.5)	0.220 (5.6)	0.480 (12.2)	0.276/0.060 (1.5/7.0)
31	1.335 (33.9)	1.115 (28.3)	0.220 (5.6)	0.630 (16.0)	0.306/0.074 (1.9/7.8)
37	1.485 (37.7)	1.265 (32.1)	0.220 (5.6)	0.780 (19.8)	0.367/0.106 (2.7/9.3)

Notes

1. Assembly identified with Glenair's name, P/N and date code, space permitting

Material/Finish

Backshell - Al Alloy
 Hardware - 300 Series CRES/Passivated

Dimensions in inches (millimeters) and are subject to change without notice.



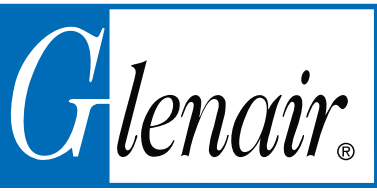

249-033 • 249-051
Jackscrew/Jackpost Kits
for Filter Micro-D Adapters and Filter D-Sub Adapters

249-033 JACKSCREW/JACKPOST KIT FOR FILTER MICRO-D ADAPTERS

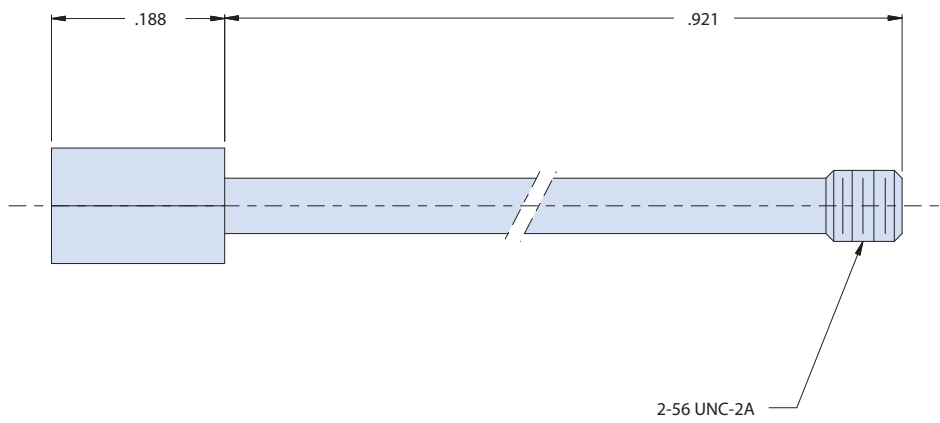
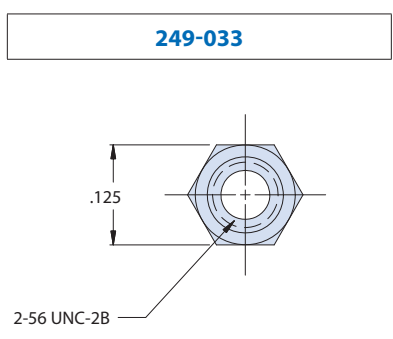

Notes

1. Remove all burrs and sharp edges
2. Kit consists of 2 Jackposts and 2 MS16633-4006 E-Clips

Material/Finish
Material: Corrosion-Resistant Steel IAW ASTM-A484 and ASTM-A582
Finish: Passivate IAW ASTM-A967

249-051 JACKSCREW/JACKPOST KIT FOR FILTER D-SUB ADAPTERS

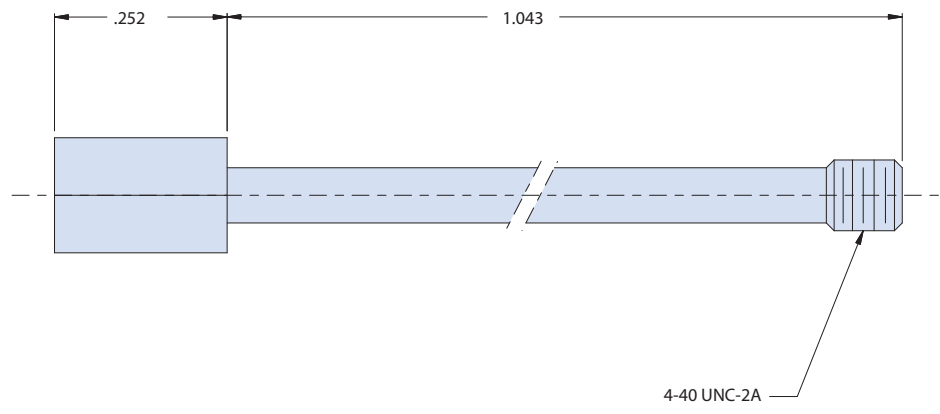
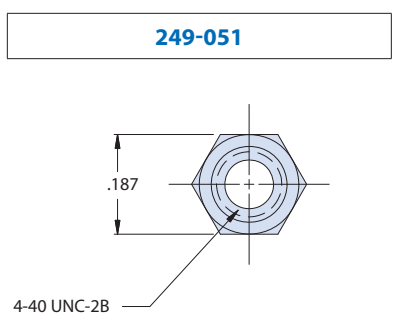

Notes

1. Remove all burrs and sharp edges
2. Kit consists of 2 Jackposts and 2 MS16633-4012 E-Clips

Material/Finish
Material: Corrosion-Resistant Steel IAW ASTM-A484 and ASTM-A582
Finish: Passivate IAW ASTM-A967

Dimensions in inches (millimeters) and are subject to change without notice.

© 2013 Glenair, Inc. U.S. CAGE Code 06324 Rev. 07.07.15 Printed in U.S.A.

179-045
Jackpost Kit
 for Rear Panel Mount Micro-D Connectors



179-045 JACKPOST KIT FOR REAR PANEL MOUNT MICRO-D CONNECTORS

How To Order			
Sample Part Number	179-045	-2	-2
Jackscrew/Jackpost Kit	for Rear Panel Mount Micro-D Connectors		
Dash No.	Table I		
Dash No.	Table II		

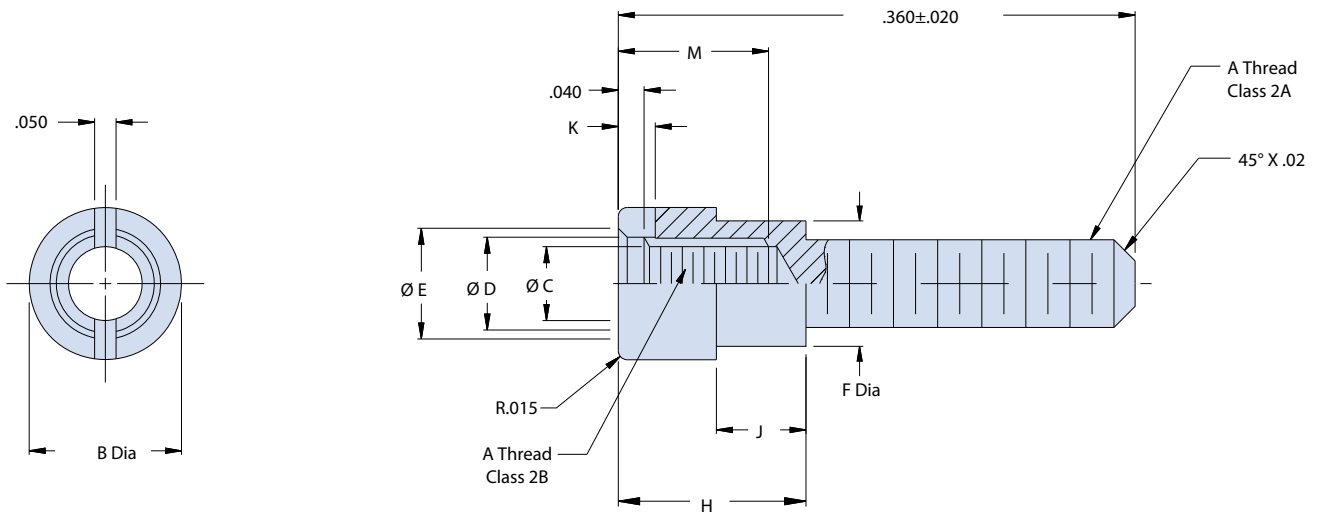

Dash No.	Shell Size	A Thread	Ø B	Ø C	Ø D	Ø E	F ± .003	G	H ± .005	M M.P.T.
2	09	2-56 UNC	.156 (4.0)	.073/.067 (1.9/1.7)	.088 (2.2)	.105 x 45°	.119 (3.0)	.125 (3.2)	.188 (4.8)	.155 (3.9)
	15	2-56 UNC	.156 (4.0)				.119 (3.0)			
	21	2-56 UNC	.156 (4.0)				.119 (3.0)			
	25	2-56 UNC	.156 (4.0)				.119 (3.0)			
	31	2-56 UNC	.156 (4.0)				.119 (3.0)			
	37	2-56 UNC	.156 (4.0)				.119 (3.0)			
51	2-56 UNC	.156 (4.0)	.119 (3.0)							
4	100	4-40 UNC	.187 (4.7)	.093/.085 (2.4/2.2)	.114 (2.9)	.131 x 45°	.140 (3.6)	.147 (3.7)	.180 (4.6)	.170 (4.3)

Dash No.	Panel Thickness	J ± .003	K ± .005
2	1/32	0.024 (0.6)	0.050 (1.3)
3	3/64	0.041 (1.0)	0.050 (1.3)
4	1/16	0.055 (1.4)	0.050 (1.3)
5	3/32	0.086 (2.2)	0.050 (1.3)
6	1/8	0.118 (3.0)	0.030 (0.8)
7	.080	0.074 (1.9)	0.050 (1.3)

Notes

1. Remove all burrs and sharp edges
2. Kit consists of 2 Jackposts

Material/Finish

Material: Corrosion-Resistant Steel IAW ASTM-A484 and ASTM-A582
 Finish: Passivate IAW ASTM-A967

Dimensions in inches (millimeters) and are subject to change without notice.

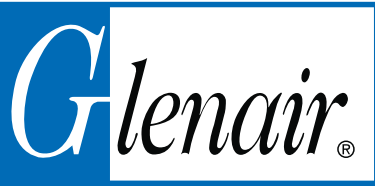

Microfilament Composite Braid How-to-Order

103-026 AND -027 AMBERSTRAND® EMI/RFI MICROFILAMENT COMPOSITE BRAIDED SHIELDING 100% COMPOSITE AND 75%/25% BLENDED VERSIONS

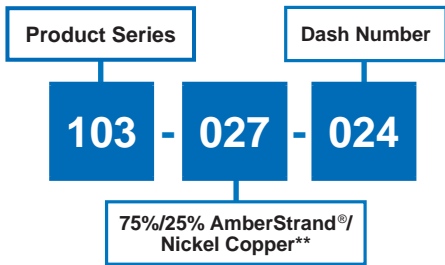
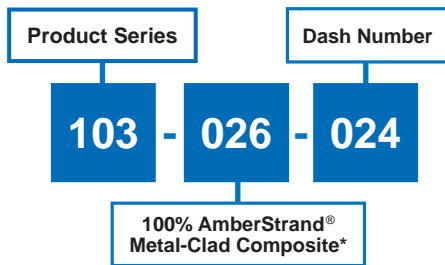

* Braid is made from nickel-plated AmberStrand composite fibers. AmberStrand is a registered trademark of Syscom Advanced Materials, Inc.

**Nickel clad thermoplastic, silver color, nickel plated copper wire/ASTM B355 CL 7 OFHC, 36 AWG

103-026 100% Composite AmberStrand®			
Part No.	Inner Diameter	Ref. Wire Bundle Range	Approximate Grams Per Foot
103-026-004	.125 (3.2)	.093 (2.4) .140 (3.5)	1.0
103-026-008	.250 (6.4)	.125 (3.2) .312 (7.9)	1.8
103-026-012	.375 (9.5)	.325 (8.2) .437 (11.1)	2.3
103-026-016	.500 (12.7)	.375 (9.5) .560 (14.2)	3.7
103-026-020	.625 (15.9)	.375 (9.5) .700 (17.8)	4.4
103-026-024	.750 (19.1)	.500 (12.7) .830 (21.1)	5.2
103-026-032	1.000 (25.4)	.780 (19.8) 1.100 (27.94)	8.0
103-026-040	1.250 (31.8)	.938 (23.8) 1.312 (33.3)	10.0
103-026-048	1.500 (38.1)	1.187 (30.1) 1.590 (40.37)	15.2
103-026-064	2.000 (50.8)	1.312 (33.3) 2.090 (53.08)	22.0

103-027 75%/25% Blended Composite AmberStrand®/Nickel Copper			
Part No.	Inner Diameter	Ref. Wire Bundle Range	Approximate Grams Per Foot
103-027-004	.125 (3.2)	.093 (2.4) .140 (3.5)	1.5
103-027-008	.250 (6.4)	.125 (3.2) .312 (7.9)	2.4
103-027-012	.375 (9.5)	.250 (6.4) .437 (11.1)	3.9
103-027-016	.500 (12.7)	.375 (9.5) .550 (13.9)	6.0
103-027-020	.625 (15.9)	.375 (9.5) .700 (17.8)	6.4
103-027-024	.750 (19.1)	.500 (12.7) .830 (21.1)	7.2
103-027-032	1.000 (25.4)	.780 (19.8) 1.100 (27.94)	11.0
103-027-040	1.250 (31.8)	.938 (23.8) 1.312 (33.3)	15.0
103-027-048	1.500 (38.1)	1.187 (30.1) 1.590 (40.37)	25.2
103-027-064	2.000 (50.8)	1.312 (33.3) 2.090 (53.08)	32.0

Specify length on purchase order. No minimums! Metric dimensions (mm) are in parentheses.

Dimensions in inches (millimeters) and are subject to change without notice.

Microfilament Composite Braid How-to-Order



103-051 ARMORLITE™ LIGHTWEIGHT EMI/RFI MICROFILAMENT STAINLESS STEEL BRAIDED SHIELDING



100% ArmorLite™

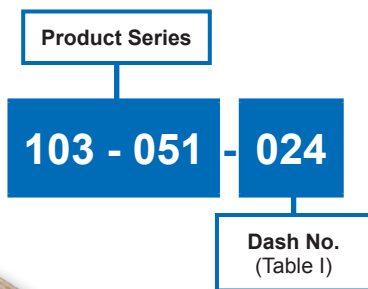

Specify length on purchase order. No minimums! Metric dimensions (mm) are in parentheses.

MATERIAL: Nickel clad/stainless steel, silver color.

Table I			
Part Number	Inner Diameter	Ref. Wire Bundle Range	Approximate Grams Per Foot
103-051-001	.031 (0.8)	.016 (0.4) .047 (1.2)	.5
103-051-002	.062 (1.6)	.040 (1.0) .075 (1.9)	1.15
103-051-004	.125 (3.2)	.093 (2.4) .140 (3.5)	1.5
103-051-008	.250 (6.4)	.125 (3.2) .312 (7.9)	2.2
103-051-012	.375 (9.5)	.250 (6.4) .406 (10.3)	2.9
103-051-016	.500 (12.7)	.375 (9.5) .560 (14.2)	4.4
103-051-020	.625 (15.9)	.375 (9.5) .700 (17.8)	4.8
103-051-024	.750 (19.1)	.500 (12.7) .800 (20.3)	5.8
103-051-032	1.000 (25.4)	.780 (19.8) 1.100 (27.9)	11.5
103-051-040	1.250 (31.8)	.938 (23.8) 1.312 (33.3)	14.0
103-051-048	1.500 (38.1)	1.187 (30.1) 1.590 (40.4)	17.3
103-051-064	2.000 (50.8)	1.312 (33.3) 2.090 (53.1)	22.8

Dimensions in inches (millimeters) and are subject to change without notice.

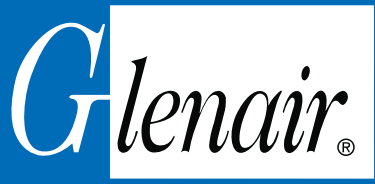

107-098 ArmorLite Single-Layer ESD Grounding Strap Light Duty, Low Profile

LIGHT DUTY LOW PROFILE ESD GROUNDING STRAP

How To Order				
Sample Part Number	107-098	-A	-12	-6
Grounding Strap	Single layer light duty ArmorLite			
Material	A = ArmorLite microfilament stainless steel braid			
Width Code	(See Table II)			
Length	Dimension in one inch increment			

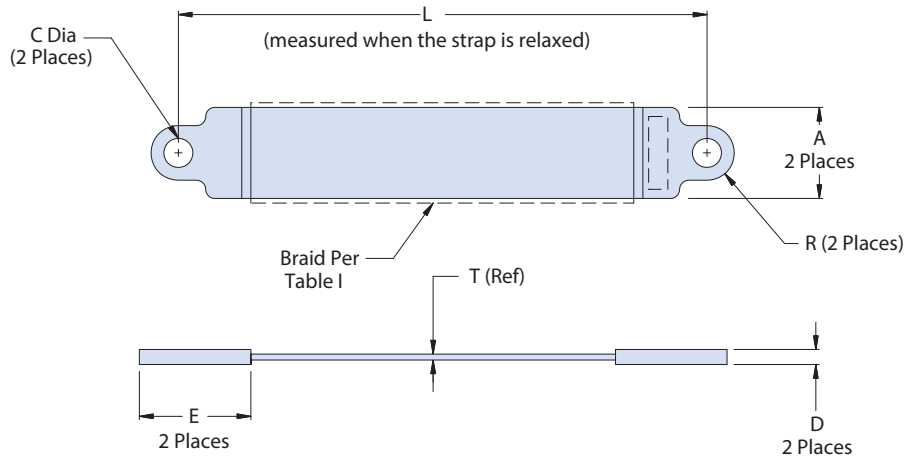

Table II: Mechanical/Electrical Parameters for ArmorLite Material

Width Code	A ± .03	C	R	D	E	T	Nom. Resistance mOhm/m* (AWG Equiv.)	Lug Junction Resistance mOhm	Weight gr/m*	Inductance nH/m (Ref. Only)	Test Current **	Tensile Strength
12	.290 (7.37)	.150 (3.81)	.145 (3.68)	.042 (1.06)	.480 (12.19)	.016 (.41)	48 (22)	0.129	9.0	1277	37	130
20	.480 (12.19)	.200 (5.08)	.240 (6.10)	.042 (1.06)	.690 (17.53)	.016 (.41)	26 (19)	0.111	13.4	1170	52	216
24	.590 (14.99)	.260 (6.60)	.295 (7.49)	.042 (1.06)	.790 (20.06)	.016 (.41)	23 (18)	0.097	17.9	1116	62	219
32	.820 (2.83)	.390 (9.91)	.375 (9.53)	.052 (1.32)	.950 (24.13)	.021 (.53)	13 (16)	0.089	35.8	1047	127	483
40	.870 (22.10)	.390 (9.91)	.375 (9.53)	.052 (1.32)	.950 (24.13)	.021 (.53)	11 (15)	0.061	40.3	1034	141	524
48	1.080 (27.43)	.390 (9.91)	.375 (9.53)	.052 (1.32)	.950 (24.13)	.021 (.53)	8 (14)	0.054	53.8	983	162	590
64	1.330 (33.78)	.390 (9.91)	.375 (9.53)	.052 (1.32)	.950 (24.13)	.021 (.53)	6 (12)	0.047	71.7	936	208	723

* Braid only, figures exclude termination lugs. **Test current is defined as the current required to reach 200° C at ambient temperature

Notes

1. Max operating temperature 200° C
2. Assembly identified with Glenair's name and part number, space permitting.
3. Parts shall withstand flexure of 250,000 cycles per EN4199-001 flex test.

Material/Finish

Lugs - copper/nickel plate per SAE AMS-26074, mat'l IAW ASTM B152, ASTM F68, ASTM B75 or MIL-T-24107
Solder - tin/copper alloy

Dimensions in inches (millimeters) and are subject to change without notice.

107-099
ArmorLite Dual-Layer Equipment Grounding Strap
Medium Duty, Low Profile



MEDIUM DUTY LOW PROFILE EQUIPMENT GROUNDING STRAP

How To Order				
Sample Part Number	107-099	-A	-12	-6
Grounding Strap	Dual layer medium duty ArmorLite			
Material	A = ArmorLite microfilament stainless steel braid			
Width Code	(See Table II)			
Length	Dimension in one inch increment			

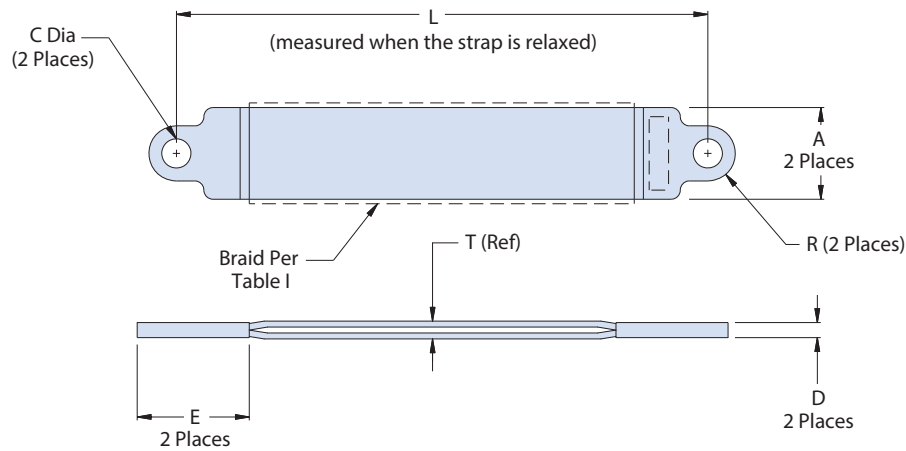

Table II: Mechanical/Electrical Parameters for ArmorLite Material

Width Code	A ± .03	C	R	D	E	T	Nom. Resistance mOhm/m* (AWG Equiv.)	Lug Junction Resistance mOhm	Weight gr/m*	Inductance nH/m (Ref. Only)	Test Current **	Tensile Strength
48	1.080 (27.43)	.390 (9.91)	.375 (9.53)	.080 (2.03)	1.15 (29.21)	.042 (1.06)	4 (11)	0.054	107.6	976	500	590
64	1.330 (33.78)	.390 (9.91)	.375 (9.53)	.080 (2.03)	1.15 (29.21)	.042 (1.06)	3 (10)	0.047	143.4	930	650	723

* Braid only, figures exclude termination lugs. **Test current is defined as the current required to reach 200° C at ambient temperature

Notes

1. Max operating temperature 200° C
2. Assembly identified with Glenair's name and part number, space permitting.
3. Parts shall withstand flexure of 250,000 cycles per EN4199-001 flex test.

Material/Finish

Lugs - copper/nickel plate per SAE AMS-26074, mat'l IAW ASTM B152, ASTM F68, ASTM B75 or MIL-T-24107
 Solder - tin/copper alloy

Dimensions in inches (millimeters) and are subject to change without notice.



Band-Master™ ATS Manual Tools and Bands

MANUAL BANDING TOOL FOR STANDARD BANDS



For Standard Bands 601 -005, -040, and -049

The 601-100 Standard Band-Master™ ATS Tool weighs 1.18 lbs., and is designed for standard flat .24" width clamping bands (601-005, 601-040 and 601-049) in a tension range from 100 to 180 lbs. Calibrate at 150 lbs. ± 5 lbs. for most shield terminations. Tool and band should never be lubricated.

Color-coded tensioning lever:
black = standard

Band-Master™ ATS Band Selection

Bands	Length		Part Number		Fits Diameter	
	in.	mm.	Flat	Pre-Coiled	in.	mm.
Short Standard Band	9.0	228.6	601-005	601-006	1.0	25.4
Medium Standard Band	14.0	355.6	601-040	601-041	1.8	47.8
Long Standard Band	18.0	457.2	601-049	601-050	2.5	63.5
Short Micro Band	5.0	127.0	601-024	601-025	0.5	12.7
Medium Micro Band	8.0	203.2	601-060	601-061	.88	22.4
Long Micro Band	14.0	355.6	601-064	601-065	1.8	47.8
Short Nano Band	6.0	152.4	601-500	601-501	.60	15.2
Medium Nano Band	9.0	228.6	601-504	601-505	.94	23.9
Long Nano Band	14.0	355.6	601-508	601-509	1.8	47.8

Cable Pull Strength for Standard Bands

Name	Material Type	Band Width	Material Thickness	Tool Setting	Cable Pull Strength
Standard	304 SS	0.24"	.020"	150 lbs	160 lbs

Dimensions in inches (millimeters) and are subject to change without notice.

STANDARD BANDS

**Short Flat 601-005
Short Precoiled 601-006**

Standard bands are precision constructed of 300 Series SST/Passivate. Short standard bands are 9.00 inches (228.6) in length and designed for use with the Band-Master™ ATS 601-100 manual banding tool or the 601-104 pneumatic banding tool. Bands should always be double wrapped and will accommodate diameters up to approximately 1.0 inches (25.4).

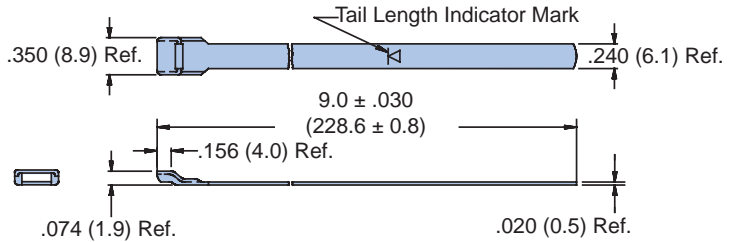

**Medium Flat 601-040
Medium Precoiled 601-041**

Standard bands are precision constructed of 300 Series SST/Passivate. Medium standard bands are 14.0 inches (355.6) in length and designed for use with the Band-Master™ ATS 601-100 manual banding tool or the 601-104 pneumatic banding tool. Bands should always be double wrapped and will accommodate diameters up to approximately 1.8 inches (45.7).

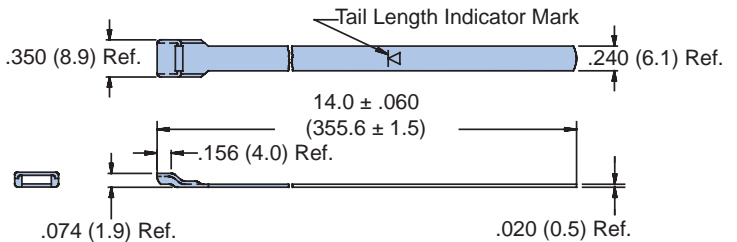

**Long Flat 601-049
Long Precoiled 601-050**

Standard bands are precision constructed of 300 Series SST/Passivate. Long standard bands are 18.0 inches (457.2) in length and designed for use with the Band-Master™ ATS 601-100 manual banding tool or the 601-104 pneumatic banding tool. Bands should always be double wrapped and will accommodate diameters up to approximately 2.5 inches (63.5).

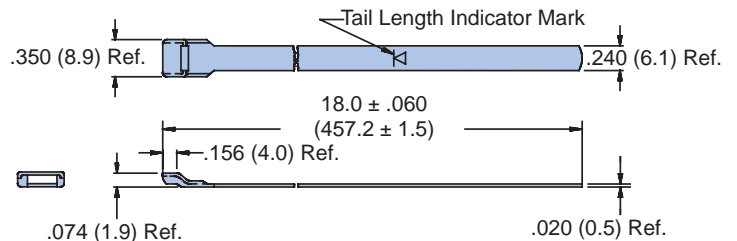

Dimensions in inches (millimeters) and are subject to change without notice.





Band-Master™ ATS Manual Tools and Bands

MANUAL BANDING TOOL FOR MICRO BANDS



For Micro Bands 601 -024, -060, and -064

The **601-101 Micro Band-Master™ ATS Tool** weighs 1.18 lbs., and is designed for micro .120" width clamping bands (601-024, 601-060 and 601-064) in a tension range from 50 to 85 lbs. Calibrate at 80 lbs ±5 lbs. for most shield terminations. Tool and band should never be lubricated.

Color-coded tensioning lever:
blue = micro

Band-Master™ ATS Band Selection

Bands	Length		Part Number		Fits Diameter	
	in.	mm.	Flat	Pre-Coiled	in.	mm.
Short Standard Band	9.0	228.6	601-005	601-006	1.0	25.4
Medium Standard Band	14.0	355.6	601-040	601-041	1.8	47.8
Long Standard Band	18.0	457.2	601-049	601-050	2.5	63.5
Short Micro Band	5.0	127.0	601-024	601-025	0.5	12.7
Medium Micro Band	8.0	203.2	601-060	601-061	.88	22.4
Long Micro Band	14.0	355.6	601-064	601-065	1.8	47.8
Short Nano Band	6.0	152.4	601-500	601-501	.60	15.2
Medium Nano Band	9.0	228.6	601-504	601-505	.94	23.9
Long Nano Band	14.0	355.6	601-508	601-509	1.8	47.8

Cable Pull Strength for Micro Bands

Name	Material Type	Band Width	Material Thickness	Tool Setting	Cable Pull Strength
Micro	304 SS	0.12"	.015"	80 lbs	80 lbs

Dimensions in inches (millimeters) and are subject to change without notice.

MICRO BANDS

Short Flat 601-024

Short Precoiled 601-025

Micro Bands are precision constructed of 300 Series SST. Short micro bands are 5.00 inches (127) in length and designed for use with the Band-Master™ 601-101 hand banding tool or the 601-105 pneumatic banding tool. Bands should always be double wrapped and will accommodate diameters up to approximately .5 inches (12.7).

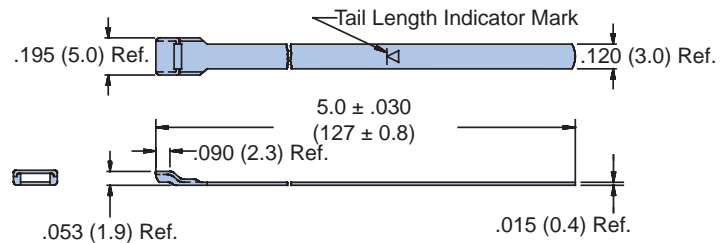

Medium Flat 601-060

Medium Precoiled 601-061

Micro Bands are precision constructed of 300 Series SST. Medium micro bands are 8.00 inches (203.2) in length and designed for use with the Band-Master™ 601-101 hand banding tool or the 601-105 pneumatic banding tool. Bands should always be double wrapped and will accommodate diameters up to approximately .88 inches (22.4).

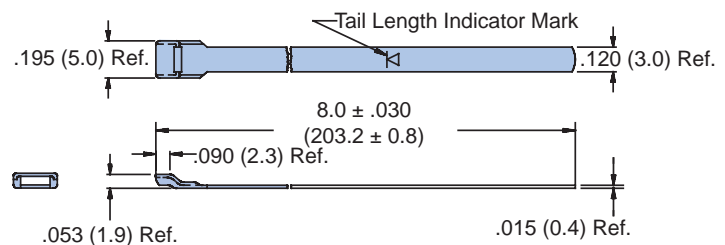

Long Flat 601-064

Long Precoiled 601-065

Micro Bands are precision constructed of 300 Series SST. Long Micro Bands are 14.00 inches (355.6) in length and designed for use with the Band-Master™ 601-101 hand banding tool or the 601-105 pneumatic banding tool. Bands should always be double wrapped and will accommodate diameters up to approximately 1.88 inches (47.7).

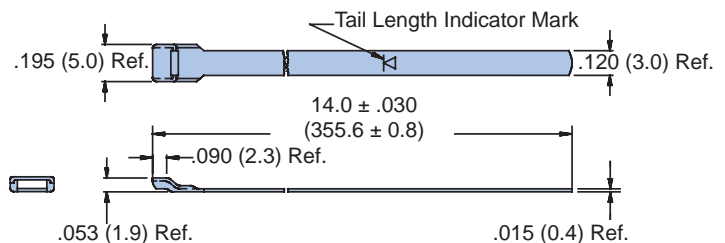

Dimensions in inches (millimeters) and are subject to change without notice.

Practical Solutions for Electromagnetic Compatibility

Designing interconnect systems which deliver clean data streams, undistorted by electromagnetic interference or pulses (EMI/EMP) is an enormous challenge. Electromagnetic Compatibility (EMC) requirements have been established to ensure that the performance of an individual electronic device is not degraded due to its proximity to high-frequency electromagnetic interference, and also to prevent the device itself from becoming a potential source of EMI. Sensitive electronic devices also need to be protected from voltage spikes generated during transient states or static discharges in the overall system.

Protecting sensitive devices and achieving electromagnetic compatibility in an interconnect environment, such as an aircraft avionics bay, is typically achieved through the application of EMI/EMP screening, grounding and filtering technologies. Interconnect industry techniques for achieving effective EMC include:

- Reflecting the signals outright,
- Reducing line-of-sight entry points in equipment and cable shields,
- Absorbing the interference in permeable material and dissipating it as heat,
- Conducting the EMI along the skin of the device/cable and taking it to ground,
- Filtering out interference at the point of interconnection, using specialized connectors which provide EMI suppression, and/or,
- Adding transient voltage suppression diodes to clamp voltage spikes.

In most applications, EMI management is not accomplished through the use of a single technique such as filtering, but rather through the combined use of various EMC technologies. While black box device manufacturers may incorporate a filter connector as a universal prophylactic against future, unknown levels of EMI, the final integration of the device into a

complex application environment typically requires the use of additional EMC technologies. At the most practical level this includes grounding conductively plated equipment housings with studs and straps, shielding cable conductors with metallic braiding, tape or conduit, and eliminating line-of-sight entry points through which electromagnetic waves can penetrate or escape the equipment. This later step is commonly performed by backshell devices which provide a reliable grounding platform for cable shielding and mechanically mask the conductor-to-contact termination from noisy waves of EMI.

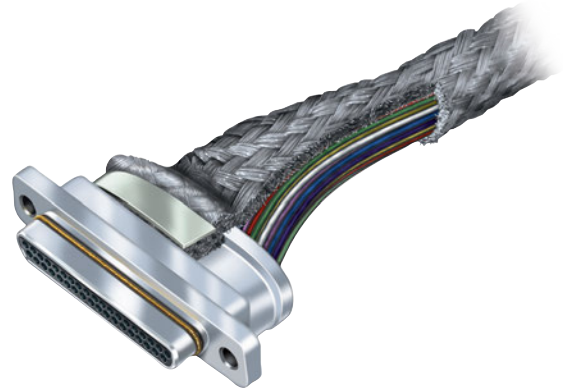

Cross-sectional view of a Micro-D connector assembly optimized for EMI noise suppression. Note the use of braided shielding, shield termination band and EMI ground spring. Effective EMI noise suppression may be accomplished solely with the use of filter connectors, but many designers prefer to augment the noise suppression provided by filters with accessory hardware such as banding backshells, conductive gaskets, grounding studs and cable shielding.

The frequency of the interfering signal is a critical concern when selecting EMI shielding devices. Low frequency magnetic waves in the 1 to 30 KHz range, for example, are most effectively shielded by absorbing the signals in permeable material. High frequency signals (30 KHz and above) are most effectively shielded by reducing entry windows and by ensuring adequate surface conductivity to ground.

Dimensions in inches (millimeters) and are subject to change without notice.

Introduction to Filter Connectors Application Checklist



Specification Reference:

- MIL-DTL-38999 Ser. 79 Micro-Crimp
- MIL-DTL-5015 Ser. 80 Mighty Mouse
- MIL-C-26482 MIL-C-28840
- MIL-DTL-83723 MIL-DTL-24308
- MIL-DTL-83513 ARINC 600
- PowerTrip

Series and/or Slash Sheet:

Shell Style:

- Jam-Nut Receptacle Plug
- Flange Mount Receptacle
- Dual Flange PCB Receptacle
- Solder Mount Receptacle
- Connector Adapter (Sav-Con®)

Shell Size/Arrangement:

Pin Count:

Contact Gender:

- Pin
- Socket

Hermetic:

- Yes
- No

Shell Rotation Position:

Shell Material and Finish:

Termination (PC Tail, Solder Cup, Piggyback Crimp, etc.):

Temperature Tolerance:

Operating: - ____°C to + ____°C
Storage: - ____°C to + ____°C

Operating Frequency Range of Effected Equipment:

Filter Capacitance:

PIN POSITION (Or Group of Pins)	FILTER VALUE* [pF] ± 20%
1	
2	
3	
4	

*1KHZ, 25°C

Desired Filter Circuit Type:

- C Filter C-L Filter
- L-C Filter Pi Filter

Labeling and Marking Instructions:

Insertion Loss:

	FREQUENCY [MHz]	ATTENUATION [dB]
GROUP 1		
GROUP 2		
GROUP 3		
GROUP 4		

IR:

_____ Volts

DWV:

_____ Volts

Capacitor Array Code:

Class	Pi - Circuit (pF)	C - Circuit (pF)
X*	160,000 - 240,000	80,000 - 120,000
Y*	80,000 - 120,000	40,000 - 60,000
Z*	60,000 - 90,000	30,000 - 45,000
A	38,000 - 56,000	19,000 - 28,000
B	32,000 - 45,000	16,000 - 22,500
C	18,000 - 33,000	9,000 - 16,500
D	8,000 - 12,000	4,000 - 6,000
E	3,300 - 5,000	1,650 - 2,500
F	800 - 1,300	400 - 650
G	400 - 600	200 - 300
J	70-120	35-60

* Filter Classes X, Y and Z are 250 VDC.
All others are 500 VDC

Note: For any capacitor array code listed, we can accommodate both C circuit and Pi circuit capacitance values.

Dimensions in inches (millimeters) and are subject to change without notice.



EMC Materials and Technologies

In interconnect cable assemblies, conductive wires and cables act as antennas to pick up and/or radiate noise. Cables can couple electrical or magnetic fields, or even radiated energy from another cable (known as “crosstalk”). The most basic of all material requirements is therefore to apply a conductive shielding around cable conductors to take electrical and magnetic field voltages to ground. Braided shielding provides the cable assembly with strength, durability and flexibility with just a slight sacrifice to effectiveness (compared to a solid conduit, conductive tape or other material). But at higher frequencies, braided shielding can lose effectiveness as the windows in the braid can become relatively large compared to the wavelength of the EMI. This is why other materials, such as metal-core conduit, conductive junction and equipment boxes, conductive gaskets, and so on also play important roles in EMC applications.

Many of the EMC materials and technologies supplied by Glenair are full-fledged product lines. Others are innovative techniques we can apply to a broad range of interconnect products. External and internal grounding springs are one such example. These gold-plated springs offer lower shell-to-shell resistance and are compatible with standard mating receptacles. Most of the connectors produced by Glenair can be equipped with grounding fingers for improved EMI shielding and grounding.

Most military grade interconnect devices and equipment housings are made of materials that accept conductive plating to provide some EMI protection outright and simultaneously facilitate grounding through the use of attached metallic or metallized textile studs and straps. While plated aluminum is the most common material for EMC applications, plated composite thermoplastic offers the ability to reduce weight and corrosion while still maintaining an effective ground path. The following section describes the many individual Glenair materials and technologies used for effective EMC.

Conductive Braided Shielding

Low frequency waves in the 1 to 30 kHz range can be absorbed into permeable conductive materials, such as shielding placed around individual conductors within a cable assembly or wire harness. This shielding material either captures the EMI taking it to ground or dissipates it as heat. Metallic braids and high-tech plated fabrics also shield cable conductors from line-of-sight penetration or escape, again by taking EMI to ground.

A wide range of cable shield termination technologies are available—the effectiveness of each style, and the complete shielding solution, can be measured using a transfer impedance test to evaluate the cable shield performance against electrostatic discharge and radiated emissions at various frequencies up to the gigahertz range. Shielding effectiveness can be calculated for a range of frequencies by taking the ratio of transfer impedance for an unprotected device or system compared to transfer impedance of a protected device or system, with the result expressed in decibels. Glenair cable shielding is manufactured in a wide range of designs and configurations. Materials include tin-plated copper, nickel-plated copper and tin-plated iron/copper. AmberStrand® is metallized composite thermoplastic material that matches metal shield performance at a fraction of the weight. Each material has specific performance advantages ranging from strength, to conductivity and corrosion protection.

Braided shields provide exceptional structural integrity while maintaining good flexibility and flex life. They also minimize low-frequency interference at audio and RF ranges. The material’s ability to contrib-



Dimensions in inches (millimeters) and are subject to change without notice.

ute to EMI reduction depends on the signal amplitude and frequency in relation to braid mesh count, wire diameter and material. Generally, the tighter the mesh and the higher the percentage of braid coverage, the more effective the shield is against high-frequency emissions. An alternative is to use more than one braid shield.

Metal Braid is offered in Tubular or Flat configurations in a variety of sizes from 1/32 inch (0.8 mm) to 2-1/2 inches (63.5 mm), and can easily be slipped over convoluted tubing and conduit as well as wire bundles, cables or similar constructions. Glenair's in-house braiding production capacity is truly impressive: More than 50 braiders, ranging from 16 to 96 carriers, provide the capability to produce large quantities of precise metal and non-metallic braid and expandable sleeving in tubular, tapered, and flat configurations.

An alternative to braided shielding, foil shields are made from aluminum laminated to a polyester or polypropylene film. Foil shields provide 100 percent cable coverage, improving protection against radiated emission and ingress at audio and radio frequencies. Because of their small size, foil shields are commonly used to shield individual pairs in multi-conductor cable to reduce crosstalk. Foil shields may also be bonded to a coaxial cable insulation or cable jacket with a layer of adhesive, allowing for faster, easier and more reliable termination.



Shield Effectiveness Series 74 Tubing
with External Tin/Copper Braid – 1 Inch Diameter

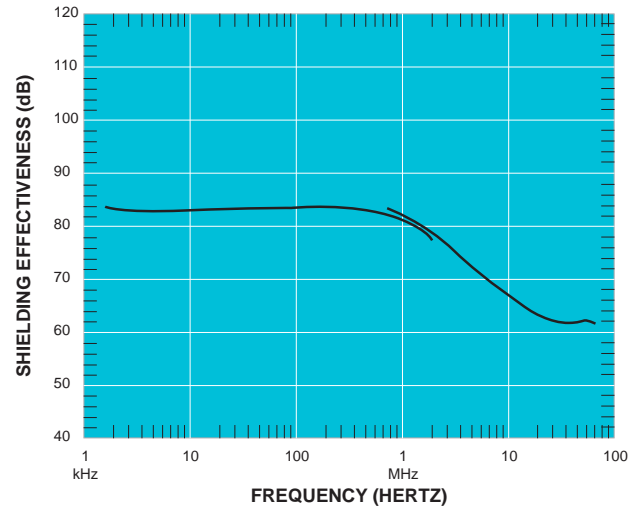

Shield Effectiveness Series 74 Tubing
with Two External Tin/Copper Braid – 1 Inch Diameter

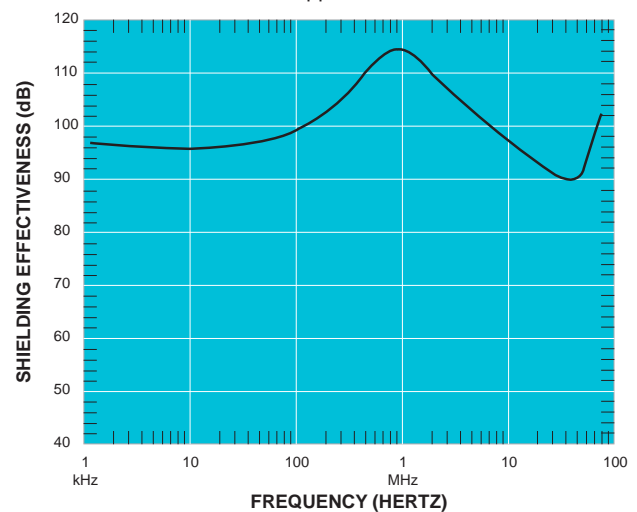

Glenair Braid Solutions

- Complete range of QQ-B-575B/A-A and ASTM B conductive braided shielding solutions
- Tubular, tapered tubular, and overbraided application options
- Every size from 1/32" to 3 3/4"
- High performance tubular fabric braided sleeving for every mechanical and wire-protection application requirement

Dimensions in inches (millimeters) and are subject to change without notice.

Swing-Arm Shield Sock Backshells

The selection of an appropriate shield termination backshell depends on many factors, including ease of assembly, cost, repairability, shield type and construction, cable diameter and type, cable jacket thickness, weight and corrosion resistance. Often the choice boils down simply to customer preference, although certainly cable construction, i.e., type of shielding and other mechanical factors is the most significant technical consideration.



As there is no single shield termination technology or methodology that will meet every customer requirement, Glenair supports every popular shield termination method with the full range of sizes and materials. Currently Glenair is able to produce an innovative backshell product, called the Swing-Arm that resolves a significant number of

design problems—including EMC. The composite thermoplastic Swing-Arm features an integrated EMI shield sock and configurable cable clamp—available with nickel/copper, tinned copper, metal-clad stainless steel or metallized composite thermoplastic shielding. The articulating arm can be configured to straight, 45° or 90° positions, reducing stock keeping requirements. The Swing-Arm also offers extremely fast, simple and trouble-free shield terminations.

Conical Ring Style Backshells

Glenair Series 38 and 39 EMI/RFI conical ring backshells provide reliable individual and overall shield termination by securing the shield under pressure between a conically shaped backshell and ground ring. Supplied in both environmental and non-environmental versions, this venerable backshell design accommodates both individual as well as overall shields and delivers low DC resistance across the termination area.

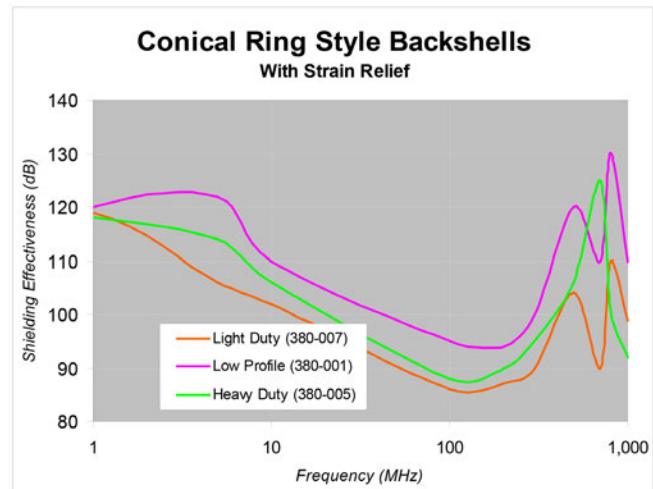
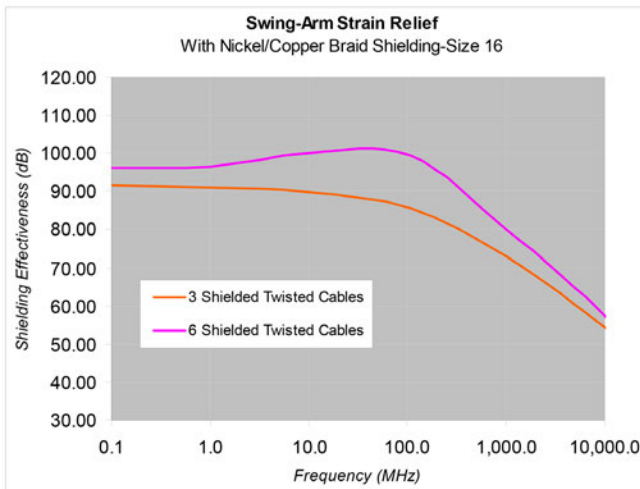
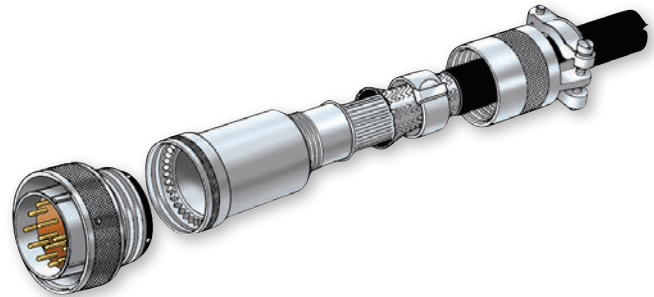

Dimensions in inches (millimeters) and are subject to change without notice.

Glenair Band-Master™ ATS

The unique low profile and smooth inside diameter of the Band-Master™ ATS steel clamping band virtually eliminates EMI leakage paths, providing reliable and repairable shield terminations. Cylindrical banding backshells are available for all Military Standard type connectors.



EMI/RFI Elliptical Banding Backshells

EMI Backshells provide shield termination as well as strain relief and mechanical protection. One-piece or split elliptical shells are chosen for rectangular connectors when the wire bundle diameter is too big to fit in a circular cable entry.

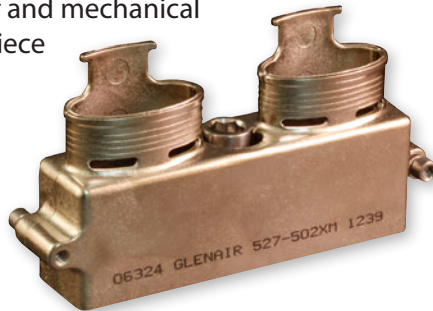

EMI/RFI Braided Grounding Straps

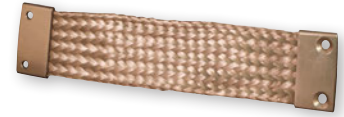

The opportunity to reduce weight and improve the flexibility and performance of grounding jumpers and straps has led many engineers to choose braided material configurations. Braided ground straps are typically supplied with either nickel-clad copper braid, or nickel-clad microfilament stainless steel braid (ArmorLite™). Ground lugs are fabricated from copper nickel plate per MIL-C-26074. The assemblies withstand flexure of 25,000 cycles and are current rated to a minimum of 50 amps.

Metal-Core Conduit

Glenair helically-wound metal conduit, overbraided with bronze, stainless steel or tinned copper shielding provides high levels of EMI protection across all radiation fields and frequencies. Metal-Core Conduit is the material of choice for TEMPEST secure communications and other applications involving sensitive electronic equipment and intense levels of EMI.

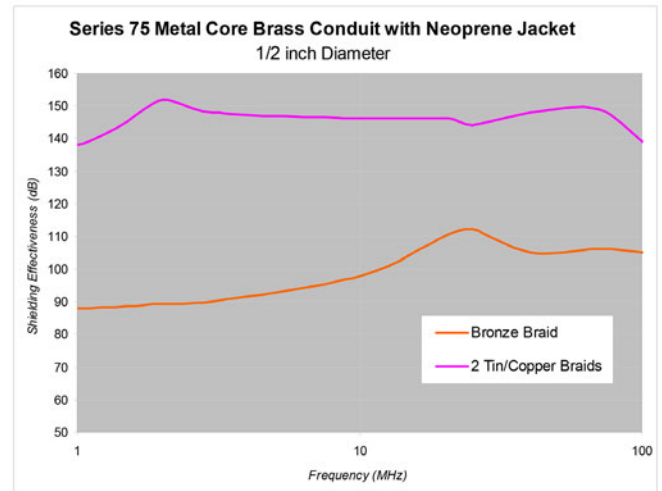
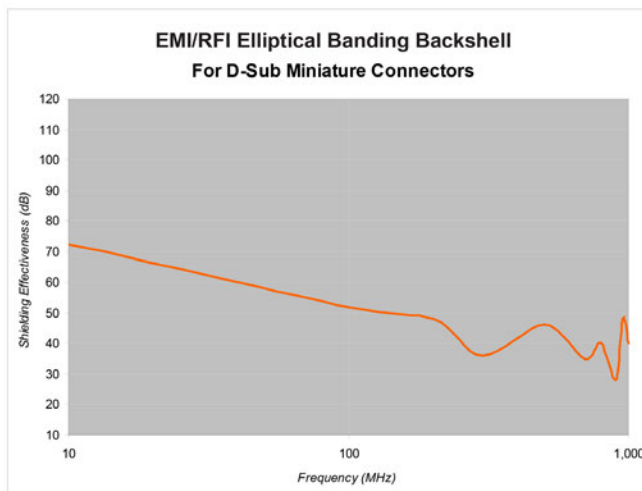

Dimensions in inches (millimeters) and are subject to change without notice.



EMI/EMP Filter Connector Overview

Filtering or suppression of electromagnetic noise within the connector package is reliably accomplished through the integration of capacitors, inductors and diodes into the connector to segregate interfering high-frequency or high voltage noise from the desired lower frequency signals. The capacitors strip off the interfering noise from the signal as it passes through the filter device. While various types of capacitor filters are available, perhaps the most widely applied is the Planar Array type. Planar Arrays are extremely effective at filtering high-frequency interference. Planar Array designs utilize ceramic capacitor arrays and ferrite inductors which externally surround each contact, and may be supplied in a single monolithic block to fit into any connector size or shape. Planar arrays may be fabricated with different capacitive values on individual pins for additional flexibility in achieving the desired level of EMC. Diodes are used to clamp the voltage below a certain value, thereby protecting the electronic circuitry. They are typically integrated into the connector using a small printed circuit board.



Ferrite elements and capacitors can be integrated into any connector package envelope.

Using filter technology has certain advantages to the electrical system engineer, most especially improved signal integrity as well as size and weight reduction. In addition, filters can be incorporated into an interconnect system late in the research and development process; for example after an unforeseen emission problem has been detected. In every filter application the signal levels and frequency bands must be well understood in order to select the appropriate mode or type of filter technology.

For example, electronic equipment used by avionic systems typically spans the electromagnetic spectrum from a few kilohertz to several gigahertz. At the low end, Omega Navigation, which is used to fix aircraft position within a network of ground based transmitters, operates in the frequency range of 10 to 14 KHz. VHF Omnidirectional Range Finders (VOR) are radio beacons used in point-to-point navigation. They operate from 108 to 118 MHz. Glideslope Systems used during landings operate in the 328 to 335 MHz range. Distance-Measuring Equipment (DME), which gauges the space between the aircraft and ground-based transponders operate at just over 1 GHz.

Clearly, potential EMI in the application environment described above covers a broad range of frequencies. Filter modes and types are consequently specified according to the EMI frequency ranges which are the source of the actual signal degradation and the operating frequency of the affected device. Certain electrical circuit criteria are also germane to filter selection, including:

- Capacitance Value
- Working Voltage
- Surge Voltage
- Dielectric Withstand Voltage
- Insulation Resistance
- Transient Protection

Dimensions in inches (millimeters) and are subject to change without notice.

Introduction to Filter Connectors

EMI/EMP Filter Connector Overview



Filter connectors appropriate for use in applications such as those referenced above are broadly identified as 'low-pass' filters (i.e. they let low frequency signals pass through and attenuate higher frequencies). The attenuation curve can be shaped using different filter types (different configurations of capacitors and inductors). These types include: Pi Filter, L-C or C-L Filter, and C Filter. These filter connector types are characterized by their relative abilities to filter noise according to capacitance, voltage values and load impedances. The simplest design is the "C", which consists of a single capacitor inserted between the signal line and ground.

While most EMI filter connectors can be used in a working temperature environment from -55 to 125° C, selected designs are optimized for higher operating temperatures. Hermetic Filter connectors provide the ultimate protection—ensuring system hermeticity while the added filter/diode elements safeguard electrical signals passing through the connector.

Prior to shipping a filtered connector, Glenair offers extensive testing, qualification and burn-in options. Tests range from a simple capacitance (C), insulation resistance (IR), and dielectric withstanding voltage (DWV), to more elaborate options such as RF insertion loss, dissipation factor, Zener/TVS diode test, ground resistance, voltage conditioning and thermal shock.

The Glenair factory, provided with the system attenuation and frequency values, relevant electrical specifications, and connector configuration details can design an effective filter device for every application (to get started, use the application checklist on page M-2). Glenair is able to supply filter technology in every cylindrical connector standard we produce including our Series 80 Mighty Mouse as well as MIL-C-38999, MIL-C-5015, MIL-DTL-83513, MIL-C-24308, and so on. Custom circular and rectangular styles are also available. Hybrid electrical/optical filter connectors are a specialty.

Common Filter Connector Types

Glenair supplies filter connectors in the following electrical configurations: C, L-C, C-L, and Pi. The following general values may be used in type selection: Single element filter connectors sporting either a single capacitor or inductor yield an insertion loss characteristic of 20dB per decade, dual element filters (capacitor plus an inductor) 40dB per decade, and triple element filters 60dB per decade. Selection is based primarily on source and load impedances but may also be influenced by the level of attenuation required at various frequencies. Please consult the factory for assistance in evaluating insertion loss values. All insertion loss values quoted for a 50 Ohm impedance.

C Circuit Filter

Single capacitor with low self inductance. This configuration is generally used to attenuate high frequency signals. The simple design allows high-frequency EMI to discharge to ground via the surrounding electromagnetic field.

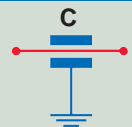

L-C or C-L Circuit Filter

Single capacitor combined with an inductive element. It is commonly used in a circuit with a both a low impedance source and a high impedance load or a low impedance load and a high impedance source. The inductive element should face the low impedance.

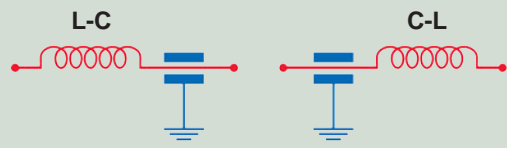

Pi Circuit Filter

Dual capacitors with a single inductive element positioned between them. The Pi filter provides exceptional high-frequency performance due to its sharper rolloff and is typically used when both source and load impedances are high.

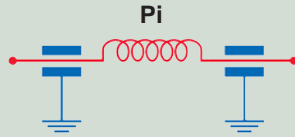

Dimensions in inches (millimeters) and are subject to change without notice.



Introduction to Filter Connectors Multilayer Ceramic Planar Capacitor Arrays

Multilayer Ceramic Planar Capacitor Arrays

Planar, multi-layer ceramic capacitive filters offer reduced size and improved performance compared to discrete discoidal or tubular capacitors. Planar array filter devices have the advantage, especially when compared to capacitive filters integrated at the circuit board level, of being bidirectionally effective at attenuating unwanted noise travelling into and out of equipment enclosures.

As mentioned above, the planar array can be designed with different capacitive values on individual pins, and pin groupings, and can also be selectively equipped with surge protection diodes. The ability to accommodate such Transient VoltageSuppressions (TVS) diodes to protect against voltage spikes from transient sources such as EMP, lightning or Electrostatic Discharge (ESD) is an additional strength of the planar array design. The planar array package can also easily accommodate ferrite elements to add inductance to the filter device. For these reasons and more, the planar array is the most common filter type specified in military aerospace and other high-performance applications.

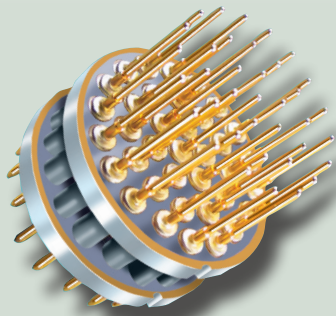

Multipin planar array filter device, assembled with its ferrite elements and connector contacts, ready for insertion into the connector shell. The flexible design allows for different capacitive values on individual pins as well as the integration of hybrid contacts such as optical termini.

The metal electrodes are plated on alternate ceramic layers with a 'hot' or ground electrode to match the contact pattern of the chosen connector. This results in a discrete capacitance value per hole—ultimately determining the EMI attenuation properties of the assembled filter device. After the layer-cake of dielectric materials and conductive elements is assembled, it is fired at high temperature to create a unified, monolithic structure.

As the figure below illustrates, the planar array is fabricated such that the capacitor positions align exactly to the pin layout positions of the connector. When combined with inductive ferrite elements, TVS diodes or other special circuitry, the final assembly is ready for insertion into the connector shell. The incorporation of filter elements into a standard cylindrical or rectangular connector will necessarily increase the overall length of the package. The extra real estate is usually added to the inside-the-box (non-mating) side of the connector receptacle. Another approach is to attach a connector adapter, or go-between, outfitted with the filter device, to the connector plug. This approach has the advantage of not requiring any dimensional changes in box design or receptacle connector package.

Typically, custom-configured planar arrays, with unique capacitive elements and values, are required to effectively address complex EMI problems such as might be encountered in an avionics bay or in the body of a missile. For this reason, planar array fabrication is accomplished using the most advanced CAD software and CNC machine tools. As critical EMI problems are often discovered late in the development process—perhaps only after equipment has been installed for use—it is critical that turnaround times in design and fabrication of custom designs are kept to a minimum. Glenair is committed to meeting the most aggressive delivery requirements for planar array type filter connectors.

Dimensions in inches (millimeters) and are subject to change without notice.

© 2013 Glenair, Inc.

U.S. CAGE Code 06324

Printed in U.S.A.

GLENAIR, INC. • 1211 AIR WAY • GLENDALE, CA 91201-2497 • 818-247-6000 • FAX 818-500-9912
www.glenair.com M-9 E-Mail: sales@glenair.com

EMI Filter and Transient Voltage Suppression Packaging

The packaging of EMI and TVS elements in standard connectors is an important element in effective EMC design. EMI/EMP connectors typically come in Mil-Spec packaging for easy intermating with Mil-Spec circular, D-sub, Micro-D and other standard formats. Such connectors are broadly identified as ‘low-pass’ filters (i.e., they let low frequency signals pass through and attenuate higher frequencies). The attenuation curve can be shaped using different filter types (different configurations of capacitors and inductors).

While the exterior of these very special connectors look normal enough, inside is another story—a planar array made of multiple layers of ceramic dielectric, separated by sheets of ceramic tape and screen printed with a pattern of metal electrodes to create a capacitor used to suppress or attenuate unwanted noise. Capacitance at each electrode protects against EMI, while carefully placed transient voltage suppression diodes guard against damage from lightning strike and other voltage surges.

Planar, multi-layer ceramic capacitive filters offer reduced size and improved performance compared to discrete discoidal chips or tubular capacitors. Planar array filter devices have the advantage, especially when compared to capacitive filters integrated at the circuit board level, of being bidirectionally effective at attenuating unwanted noise travelling into and out of equipment enclosures.

As critical EMI problems are often discovered late in

the development process—perhaps only after equipment has been installed for use—it is critical that turnaround times in design and fabrication of both standard and non-standard designs are kept to a minimum. Glenair is committed to meeting the most aggressive delivery requirements for planar array type filter connectors.

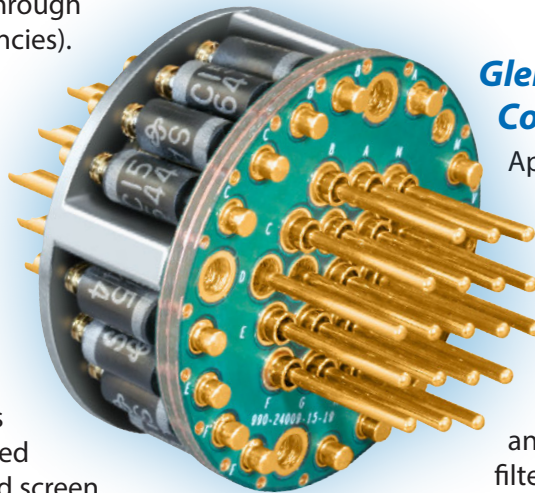

Glenair's Growing Filter Connector Availability

Applications requiring filtered connectors generally call for specific plating, mounting style, keying, shell size, contact layout, contact gender, termination, and frequency filtration. Typically, the filtered connector is either replacing an existing non-filtered receptacle, or it must mate with an existing cable plug. In some cases the filtering element is built into a connector go-between or saver. Whatever the packaging requirement, Glenair is committed to a “no gaps” product availability model whereby we can quickly build and ship any possible filter connector configuration for industry standard connector families such as MIL-DTL-38999, MIL-DTL-83513 and our own Series 80 “Mighty Mouse.”

Shell Size and Contact Count	Capacitance Codes
9	A, B, D, F
15	A, D
21	A, C, D
25	B, D, F
31	D
37	B, D, F

Dimensions in inches (millimeters) and are subject to change without notice.



Introduction to Filter Connectors EMI Filters and Transient Voltage Suppression Packaging

We currently stock some finished filtered connector parts in our Same Day inventory, and we will continue to add to this stock. More importantly, we have placed into inventory a wide range of the longest lead time component—ceramic planar filter arrays—in the most popular capacitance values. This filter array stocking program enables Glenair to provide the industry's fastest delivery of finished filtered connectors. In addition, we now have the in-house capability to manufacture our own ceramic planar capacitor arrays. This vertical integration will allow us to continue to add to component stock and reduce lead times even further.

Listed below are the current filtered connector families available for the fastest delivery in the industry. For any capacitor array code listed, we can accommodate both C-Section and Pi-Section capacitance values.

Shell Size Layout	Contact Count and Size	Capacitor Array Codes
11-35	13 #22D	B
13-35	22 #22D	D, E, F
15-35	37 #22D	E, X
17-8	8 #16	A
17-35	55 #22D	D, E, F
21-35	79 #22D	G
23-21	21 #16	X
23-35	100 #22D	G
25-29	29 #16	D
25-35	128 #22	D
25-43	20 #16, 23#20	C

MIL-DTL-38999 series I, II, III, and IV connectors in any plug or receptacle style, along with any material, plating, or filtration in the size and contact layouts with the capacitor codes listed below. These listed filter arrays make more than 142,000 D38999 finished parts. And more D38999 filter array layouts are being added to stock every day!

Mighty Mouse Series 801, 804, 805, and 800 in plug or any receptacle style, material, plating, or filtration are available in the size and contact layouts with the

Shell Size	Contact Count and Size	Capacitance Codes
5	3 #23	A
6	4 #23	A, D
6	7 #23	A, D
7	10 #23	A, D
8	13 #23	D
9	19 #23	A
10	26 #23	A, D
13	37 #23	A
16	55 #23	A
17	85 #23	A

capacitor codes listed above. These listed filter arrays can make more than 29,000 Mighty Mouse finished parts and more Mighty Mouse filter array layouts are being added to stock every day!

Micro-D Connectors in Solder Cup, Pre-Wired Pigtailed, Vertical Printed Circuit Boards, Right Angle Printed Circuit Boards and In-Line Adapters in any material, plating, or filtration are available in the size and contact counts with the capacitor codes listed below. These listed filter arrays can make almost 35,000 Micro-D finished parts (along with an essentially infinite number of pigtail Micro-D part numbers pre-wired to any length). Again, more Micro-D filter array layouts are being added to stock every day!

In addition to standard catalog products, Glenair filter connector designs may be customized for use in a wide range of application environments including avionic systems, down-hole drilling and logging devices, naval and marine platforms, network-centric ground warfare systems, and missile and satellite/space applications. Please call the factory or visit our website for more information.

Left to right: standard connector, filter connector, TVS connector



Dimensions in inches (millimeters) and are subject to change without notice.

EMP and TVS Defined

Electromagnetic Pulse (EMP) refers to the intense radio frequency pulses produced by nuclear explosions at high altitudes. Other names for this include Nuclear EMP (NEMP) and High-Altitude EMP (HEMP). Similarly, System Generated EMP (SGEMP) refers to electrical noise resultant from large amounts of composite skin used in satellites, aircraft and helicopters that discharge over time. Like other forms of electromagnetic interference, EMP can have a destructive effect on sensitive electronic devices, particularly those used in mission-critical military applications. This occurs if and when the EMP couples to an antenna or an unshielded cable and passes unmolested into an electronic device. EMP hardened equipment is designed to protect vital communications at a time when unhardened devices are likely to fail. Thus it is a standard requirement for many military applications to proactively protect certain devices from EMP via the integration of Transient Voltage Suppression technologies into the connectors that service the device.

Transient Voltage Suppression (TVS) technologies are designed to shunt voltage transients directly to ground before such surges can damage sensitive electronic equipment. Individual TVS diodes as well as diode modules may be incorporated directly into the filter connector package to provide optimal protection for either individual contacts or groups of contacts without significant increases in connector size or weight. Individual circuit protection diodes and diode modules are available for all connector types and are routinely stocked by Glenair to reduce lead-times. RTCA DO-160 and other electrical performance standards now define acceptable benchmarks for withstanding electromagnetic pulse, lightning strike, or other induced voltage surges.

Hermetic Packaging

Hermetic connectors are specified for applications as divergent as submarines and orbiting satellites. They are deployed to resist moisture ingress in underground applications and to withstand pressure differentials in vacuum chambers, laboratory equipment and commercial and military aircraft. Hermetic connectors, such as the MIL-DTL-38999 Series I, II, III and IV supplied by Glenair, are principally designed for use in military aerospace—in fact, the requirement for connector hermeticity was originally driven by military electronic applications. But the products are equally at home in commercial applications such as oil-patch logging equipment or medical devices.

Hermetic connectors are constructed from a core component-set that includes the connector shell, a vitreous glass insert and the selected contacts. Shells may be machined from stainless steel or Kovar[®], an iron-nickel-cobalt alloy with a co-efficient of expansion closely balanced to the glass inserts. Contacts used in hermetic connectors must be fabricated from high-grade iron/nickel materials that can withstand high-heat, and bond effectively to the vitreous glass seal.

As with other connector families, hermetic customers may specify the connector coupling style (threaded, bayonet, etc.), pin or socket gender and layout, contact termination type (solder cup or PCB termination), conductive or non-conductive finish, polarization and so on. Glenair's complete in-house hermetic capability affords us the ability to produce a wide-range of special purpose hermetic connectors designed to meet individual and unique customer specifications—such as EMI/EMP filtering.

Hermetic class EMI/EMP filter connectors are available throughout our complete range of filtered connector products in both Pi and C from 35 pF to 56000 pF. Connector platings and materials are offered in class H2 (stainless steel, electrodeposited nickel).

Dimensions in inches (millimeters) and are subject to change without notice.

Transient Voltage Suppression

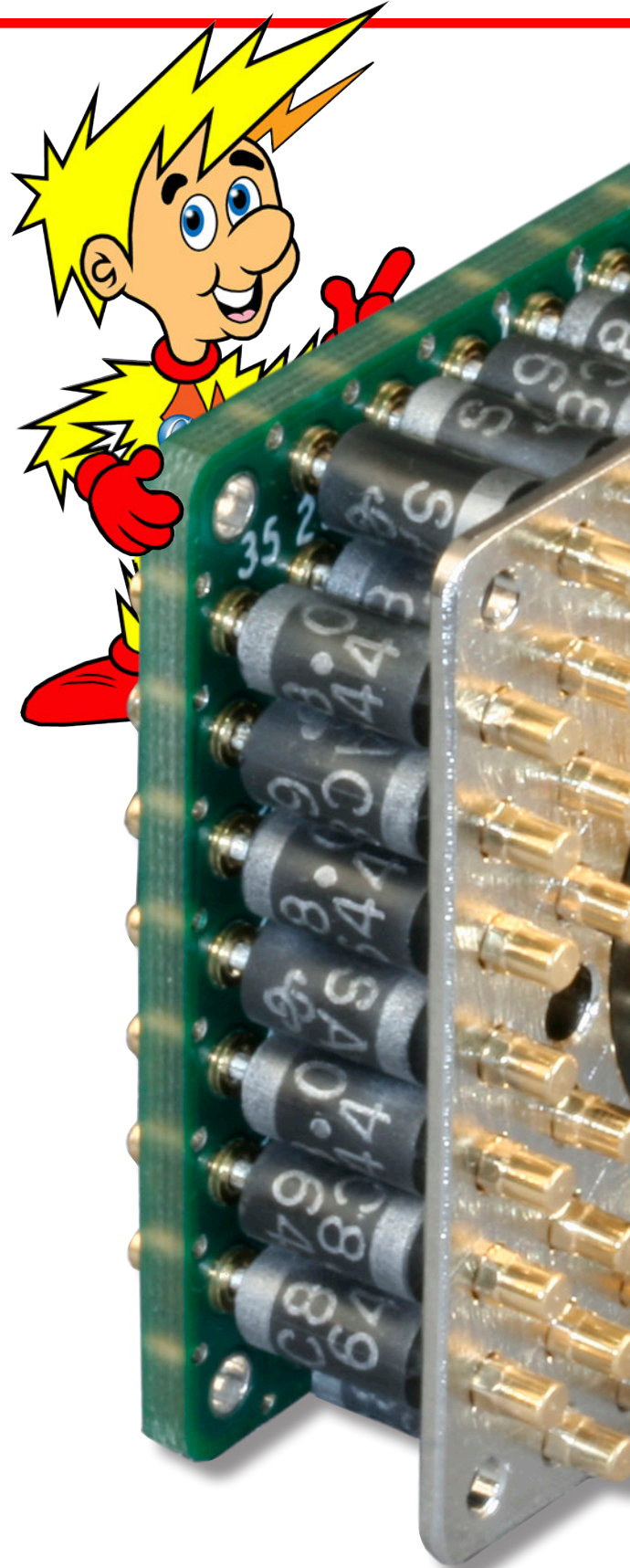
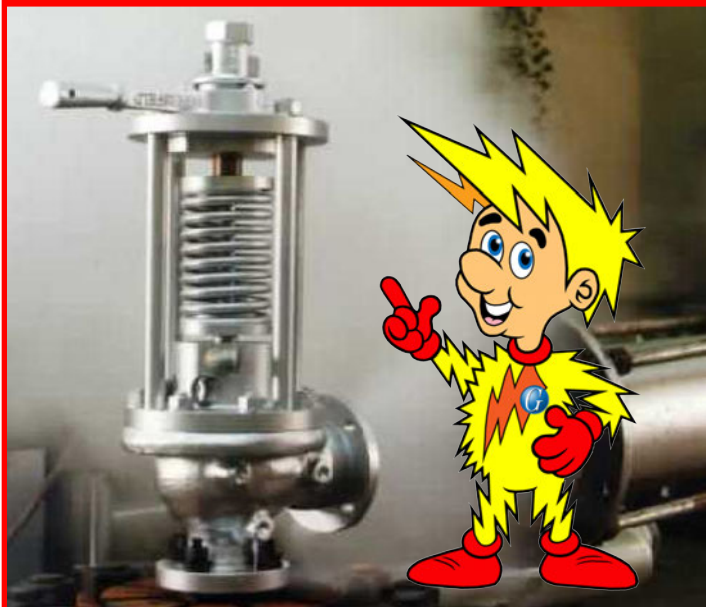
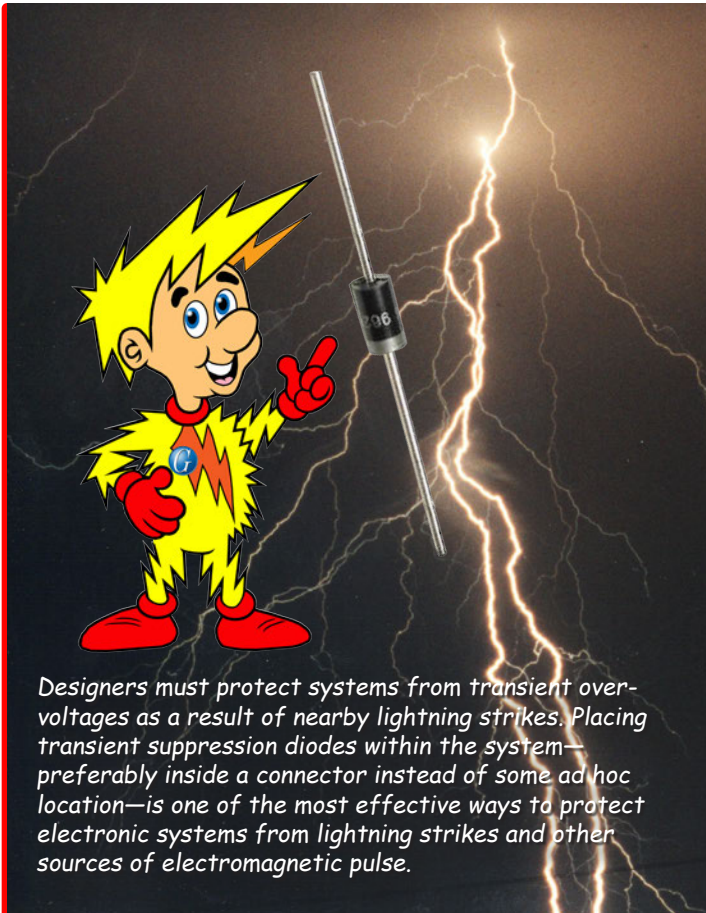

Workshop with Serge Gigawatt

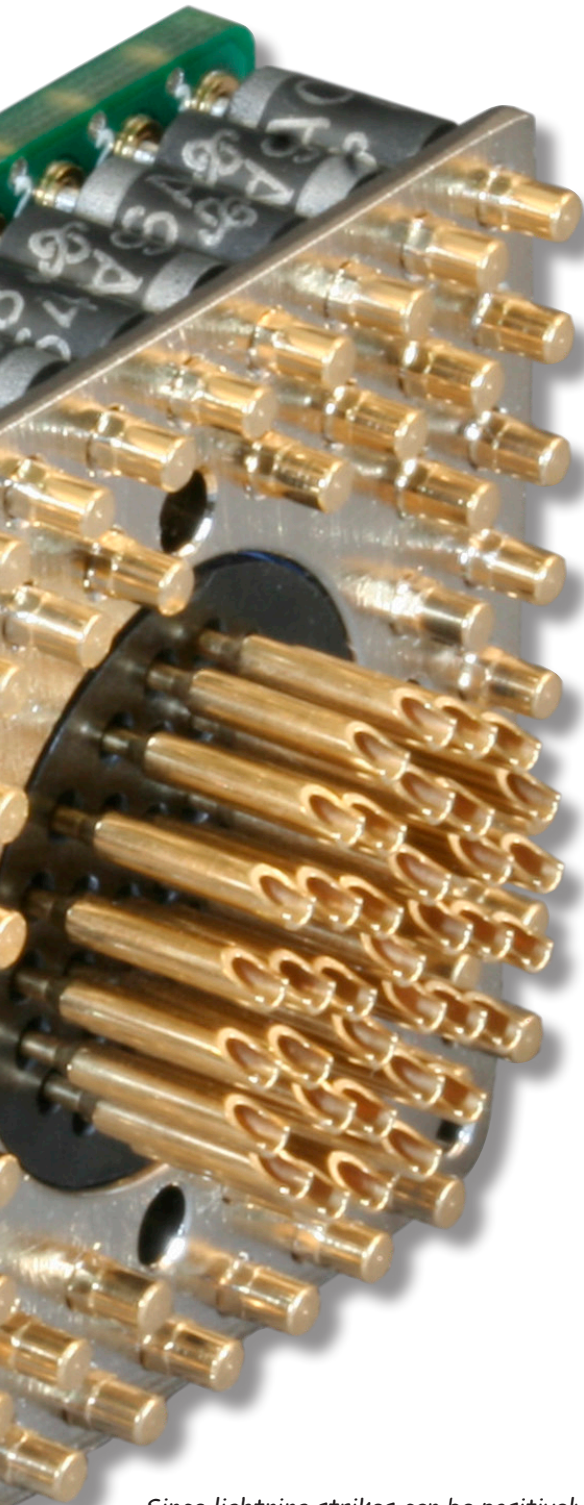

Since lightning strikes can be positively or negatively charged, special bi-directional diodes are available. If a system does not already have transient suppression diodes somewhere "in the box," Glenair can include diodes on EMI filtered or non-filtered connectors.

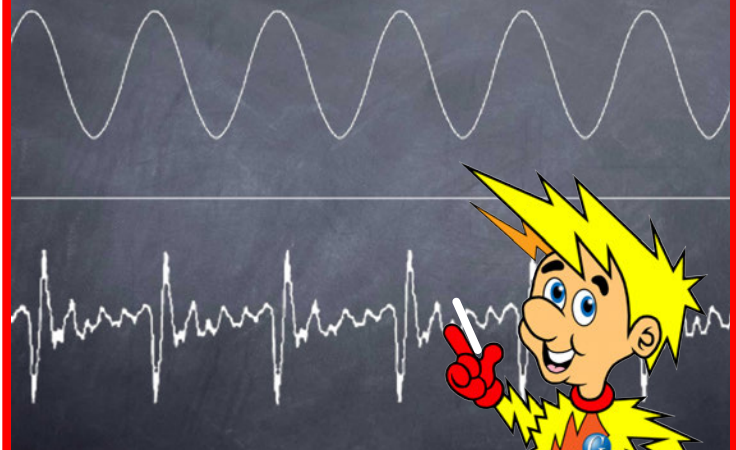

When specifying transient voltage suppression for a given lightning strike waveform (or "shape") and level (or magnitude), diodes must be compatible with EMI filter dielectric withstanding voltage (DWV) rating.

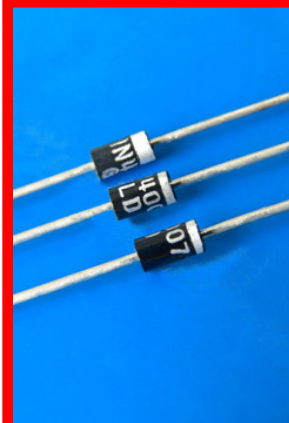

Diode power is rated in watts for a given pulse shape and pulse duration. Typically the reference values are given for a 10/1000 μ s pulse. This means that the diode can absorb the peak power rated for a pulse with 10 μ s rise time and 1000 μ s fall time. If the system is subjected to a different pulse shape or duration the value must be adjusted accordingly. The table on the following page does just that for RTCA DO160 lightning strike.

For high speed applications, diode capacitance and trace inductance are critical. Glenair engineers will recommend a suitable design for each application. This may involve using extremely compact surface mount diodes within the pin field of the connector, as shown below.

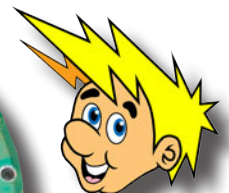
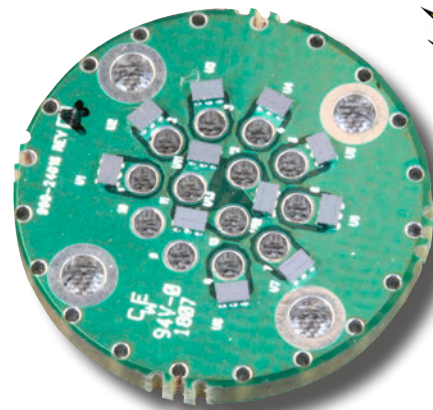



Introduction to Filter Connectors Transient Voltage Suppression Diode Selection Guide

Diode Power Selection for Lightning Strike Waveform Threats

DO 160 Waveform	Level	Open Circuit Voltage/Short Circuit Current V/A	Diode Peak Voltage (Vwm)	Diode Clamp Voltage (Vc)	Recommended Diode Power (Watts)
1 MHz Damped Ringing Sine 3	1	100/4	5 to 60	9.2 to 96.8	600
	2	250/10	5 to 150	9.2 to 243	600
	3	600/24	5 to 170	9.2 to 275	600
	4	1500/60	5 to 54	9.2 to 87.1	600
			58 to 150	93.6 to 243	1500
			160 to 170	259 to 275	3000
	5	3200/128	5 to 22	9.2 to 35.5	600
			24 to 60	38.9 to 96.8	1500
			64 to 130	103 to 209	3000
			150 to 170	243 to 275	5000
Double Exponential 6.4 x 70 μsec 4	1	50/10	5 to 30	9.2 to 48.4	600
	2	125/25	5 to 75	9.2 to 121	600
	3	300/60	5 to 17	9.2 to 27.6	600
			18 to 26	29.2 to 42.1	3000
			28 to 110	45.4 to 177	5000
	4	750/150	120 to 170	193 to 275	15000
			5 to 8.5	9.2 to 14.4	3000
			9 to 60	15.4 to 96.8	5000
	5	1600/320	64 to 170	103 to 275	15000
			5 to 24	9.2 to 38.9	5000
			26 to 78	42.1 to 126	15000
			90	147	30000
Double Exponential 40 x 120 μsec 5A	1	50/50	5 to 30	9.2 to 48.4	1500
	2	125/125	5 to 75	9.2 to 121	3000
	3	300/300	5 to 15	9.2 to 24.4	3000
			17 to 170	26.7 to 275	15000
			180	291	30000
	4	750/750	17 to 22	26.7 to 35.5	15000
			30 to 48	55.2 to 77.4	30000
	5	1600/1600	None		

Dimensions in inches (millimeters) and are subject to change without notice.

Introduction to Filter Connectors

Transient Voltage Suppression

Diode Selection Guide



Tables for the selection of diodes and recommended DWV for a specified waveform voltage threat.



1. Determine the specification threat waveform and level.
2. Determine the maximum clamping voltage that the system can tolerate (this may be a different value for each pin of the connector).
3. Move down the table to the waveform and Voc/Isc (Open Circuit Voltage/Short Circuit Current) that is covered in the specification.
4. Move across the table left to right and select the recommended diode power level.
5. If the application is a high frequency data line, a low capacitance diode will be needed. There is no difference in the power rating.
6. High speed data lines, Ethernet or USB, cannot tolerate much capacitance at all. These will need a special diode and no filter can be used.
7. If a filter is to be used in the application, consult EMI Filter Rating table (below) to determine the minimum DWV voltage needed to protect the selected filter capacitance.
8. The filter DWV rating applies with or without a diode.

EMI Filter Rating in Dielectric Withstanding Voltage (DWV) For Compatibility with Transient Suppressing Diodes										
DO 160 Waveform	Level	Waveform (Voc)	Recommended Dielectric Withstanding Voltage ▼	Capacitance pF Minimum						
				19000	16000	9000	4000	1650	400	200
1 MHz Damped Ringing Sine	1	100	Recommended Dielectric Withstanding Voltage ▼	500	500	500	500	500	500	500
	2	250		500	500	500	500	500	500	500
	3	600		500	500	500	670	720	720	720
	4	1500		740	840	1210	1660	1800	1800	1800
	5	3200		1580	1790	2580	3530	3840	3840	3840
Double Exponential 6.4 x 70 µsec	1	50		500	500	500	500	500	500	500
	2	125		500	500	500	500	500	500	500
	3	300		500	500	500	500	500	500	500
	4	750		820	850	900	900	900	900	900
	5	1600		1920	1920	1920	1920	1920	1920	1920
Double Exponential 40 x 120 µsec	1	50		500	500	500	500	500	500	500
	2	125		500	500	500	500	500	500	500
	3	300		500	500	500	500	500	500	500
	4	750		900	900	900	900	900	900	900
	5	1600		1920	1920	1920	1920	1920	1920	1920

Dimensions in inches (millimeters) and are subject to change without notice.



INSERTION LOSS											
Insertion Loss, dB Minimum, 25°C											
Frequency	X	Y	Z	A	B	C	D	E	F	G	J
1 MHz	22	16	13	6	5	3	—	—	—	—	—
10 MHz	41	36	33	24	23	16	8	4	—	—	—
100 MHz	56	53	52	41	39	35	28	21	10	5	1
500-1000 MHz	60	57	57	50	49	46	41	34	23	17	8

CAPACITANCE	
Class	C - Circuit (pF)
X*	80,000 - 120,000
Y*	40,000 - 60,000
Z*	30,000 - 45,000
A	19,000 - 28,000
B	16,000 - 22,500
C	9,000 - 16,500
D	4,000 - 6,000
E	1,650 - 2,500
F	400 - 650
G	200 - 300
J	35-60

* Filter Classes X, Y and Z are 250 VDC.
All others are 500 VDC



INSERTION LOSS											
Insertion Loss, dB Minimum, 25°C											
Frequency	X	Y	Z	A	B	C	D	E	F	G	J
1 MHz	23	19	17	10	8	5	1	—	—	—	—
10 MHz	70	55	52	40	35	25	14	8	2	0.8	—
100 MHz	75+	75+	75+	62	60	57	50	40	15	13	4
500-1000 MHz	75+	75+	75+	66	62	60	58	52	32	22	15

CAPACITANCE	
Class	Pi - Circuit (pF)
X*	160,000 - 240,000
Y*	80,000 - 120,000
Z*	60,000 - 90,000
A	38,000 - 56,000
B	32,000 - 45,000
C	18,000 - 33,000
D	8,000 - 12,000
E	3,300 - 5,000
F	800 - 1,300
G	400 - 600
J	70-120

* Filter Classes X, Y and Z are 250 VDC.
All others are 500 VDC

Notes

Standard voltage rating is 500 VDC DWV.

Insertion loss values quoted are for 50Ω impedance and no load condition.

Classes X, Y and Z are 250 VDC DWV. Consult factory for additional information.

Some shell configurations may require extra length for classes X, Y and Z.

Other configurations available. Consult factory.

Dimensions in inches (millimeters) and are subject to change without notice.

Insertion Loss Evaluation

Insertion loss is an important specification to consider in the selection of filter connectors. Insertion loss is a measure of the degradation experienced by a signal when a device, such as a connector, is inserted into the transmission path.

When a filter element performs its job of stripping signal noise from a transmission line, it may attenuate a portion of the desired signal as well. Measured in decibels (dB), insertion loss should be minimized in sensitive electronic systems which may operate at extremely low current levels. Typically, some amount of insertion loss is considered acceptable to accomplish the necessary signal selectivity, since the signal can always be re-amplified post-filtering. However, in many applications, too large a loss may ultimately result in the unacceptable degradation of system performance.

The evaluation of insertion loss is performed over a specific frequency range—i.e. a spectrum that extends from one limiting frequency to another. The intent being to measure signal degradation for each filter type across the actual operating frequencies of the equipment under consideration. Note that each filter type may yield different (theoretical and actual) insertion loss values depending on the specific capacitance and inductance ratings of the filter elements. Effective EMI/EMP filtering is, therefore, a balance between the purposeful attenuation of signal noise and the unfortunate degradation of signal strength—both conditions directly attributable to the insertion of the filter device into the system. Sensible EMC design should, as a consequence, always incorporate conventional grounding and shielding of interconnect cabling and equipment housings in anticipation of unexpected EMI problems. The tables on the opposite page explain predictable insertion loss [dB] for each filter type (C, L, and Pi), at the available capacitance ratings across a common frequency range [MHz].

Custom Options in Filtered Connectors

Glenair filter connector designs may be optimized for use in a wide range of application environments including avionic systems, down-hole drilling and logging devices, naval and marine platforms, network-centric ground warfare systems, and missile and satellite/space applications. Common electrical customizations include unique capacitance values on individual lines, electrostatic discharge designs, transient voltage suppression diodes, grounded holes and feed-throughs, as well as the incorporation of customer-specified filter architectures including Pi, C, L-C, C-L and T configurations.

Mechanical packaging options in EMI/EMP filter connectors include:

- Hybrid Fiber Optic/Electrical Contacts
- Hermetic Sealing
- Dual-Flange PCB Mount Designs
- Composite Thermoplastic Shell Materials
- Variable Length PCB Tails
- Piggy-Back Crimp Contacts
- EMI Grounding Fingers and Gaskets
- In-Line, Feed-Through, Plug and Other Shell Styles

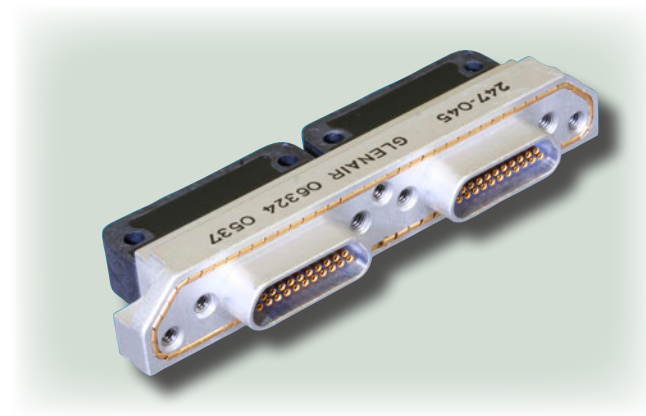

Custom dual plan Micro-D filter connector with EMI gasket and right angle PCB mounting. Glenair can apply a broad range of custom shell configurations, filter values, TVS technologies—even hybrid fiber optic contacts—into any standard connector package.

Dimensions in inches (millimeters) and are subject to change without notice.

© 2013 Glenair, Inc.

U.S. CAGE Code 06324

Printed in U.S.A.



Introduction to Filter Connectors Space Grade Applications, Soldering and Lightning Strike

Space Grade Applications

Nonmetallic materials such as rubber, plastic, adhesives and potting compounds can give off gasses when subjected to a vacuum or high heat. For space grade applications, Glenair offers a 24 hour 125° C thermal vacuum outgassing process to ensure our filter connector products do not give off gaseous molecules that might harm sensitive optical or electronic equipment.

The space industry has adopted a standardized test procedure, ASTM E 595, to evaluate outgassing properties of products that contain polymer materials. In the ASTM test, material samples are heated to 125° C at a vacuum of 5×10^{-5} torr for 24 hours. The test sample is then weighed to calculate the Total Mass Loss (TML), which may not exceed 1.00% of the total initial mass. Likewise the quantity of outgassed matter is weighed to determine the Collected Volatile Condensable Material (CVCM), which may not exceed 0.10% of the original specimen mass.

Glenair routinely performs both bakeout and thermal vacuum outgassing procedures on connector products that must conform to NASA screening or other outgassing standards. Our experience has been that the simpler bakeout process is more than adequate to meet the ASTM E 595 benchmark of 1.00% TML and 0.10% CVCM. Glenair is well versed in supplying filter connector products that are optimized for use in space grade applications, and we supply filter connectors compliant to EEE-INST-002, Table 2G, the recognized standard for spacegrade filter connectors.

Soldering

Our filter connector engineers are frequently asked about any special handling procedures that are required when soldering PC Tail and Solder-cup contacts. At issue is the potential to damage filter elements due to the high heat of the soldering process. The short answer is that any trained and qualified operator can complete the operation without any special precautions. While it certainly can't hurt to take some basic precautions such as preheating the connector or utilizing a heat sink on individual

contacts, our tests have revealed that, under normal conditions, the temperature of the ceramic filter array is not radically raised during solder termination of the contacts. Even in tests where we used a solder iron temperature of 350°C and an extremely long 'touch time' of 90 seconds, no adverse effects were observed. In fact, temperature at the ceramic remained well below 100°C at all times.

To prevent detrimental intrusion of cleaning solvents/water into the connector when terminating, the connector must be protected IAW IPC J-STD-001 and/or NASA STD-8739.3. For assistance and/or additional information, please contact the factory.

Composite Connectors and Lightning Strike

Composite thermoplastic materials, such as the 30% glass filled polyetherimide (PEI) used in Glenair's MIL-DTL-38999 Series III Wall Mount Receptacle Connector (240-011) have been tested for mechanical and electrical survivability to direct and indirect lightning strike. At issue is the ability of the composite connector shell to maintain its electrical continuity in the event of an intense voltage surge resulting from lightning strike.

In testing in accordance with MIL-STD-1344, items are subjected to waveform 1 and 5B using a high current generator. Items must remain functional without degradation of the unit's electrical performance, including filtering elements and TVS diodes and modules. Waveform 1 and 5B are applied starting at 3kA increasing to 20kA checking continuity measurements at set intervals. Waveform 1 is additionally subjected to an oscillatory wave starting at 30kA and increasing in 10kA steps until failure in continuity is measured.

While larger composite connector shell sizes (12 to 24) conform to MIL-STD-1344, smaller sizes (8 and 10) fail the test. Customers should select alternative materials, aluminum or stainless steel, when specifying small connector shell sizes in applications subject to lightning strike.

Dimensions in inches (millimeters) and are subject to change without notice.

© 2013 Glenair, Inc.

EMI/EMP Filter Connectors

U.S. CAGE Code 06324

Printed in U.S.A.

GLENAIR, INC. • 1211 AIR WAY • GLENDALE, CA 91201-2497 • 818-247-6000 • FAX 818-500-9912
www.glenair.com M-19 E-Mail: sales@glenair.com

Rev. 12.07.20

Introduction to Filter Connectors EMI/EMP Glossary



Absorption Loss: That part of shielding effectiveness dealing with energy absorption through a metal barrier.

Attenuation: Reduction in the quality or magnitude of an electrical signal. Suppression of EMI noise in the interconnect transmission path.

Aperture Leakage: Compromise in shielding effectiveness from holes, slits, and slots from braid, windows, cooling openings, and joints of metal boxes where EMI can get in or out.

Bandwidth: The frequency interval between the upper and lower 3 dB down response of a receiver.

Broadband EMI: Electrical disturbances whose frequency spectrum cover several octaves or decades in the frequency spectrum or exceed the receiver bandwidth.

Capacitance: The measure or ability of a multilayer ceramic planar array to capture and store electrical energy.

Common Mode (CM): As applied to two or more wires, all currents flowing therein with the same polarity.

Conducted Interference: EMI transmitted along an unshielded conductor or cable.

Coupling Path: The conducted or radiated path by which interfering energy gets from a source to a victim.

Cross Modulation: Energy from one transmitter that causes the modulation to change on a received signal from another transmitter.

Crosstalk: Electromagnetic energy bleed across dielectric materials, for example, in twisted pair cable sets or across adjacent connector contacts, disrupting the electrical signals in each respective circuit.

Differential Mode (DM): Voltages or currents on a wire pair that are of opposite polarity.

Dielectric Withstanding Voltage (DWV): Rating, expressed in volts at a given frequency at ambient temperature defining the maximum voltage a dielectric material can withstand before failing.

Drain: path by which charges absorbed by a conductor move to ground in a properly grounded system.

Electric Field: A radiated wave's potential gradient in volts per meter (V/m).

Electrical Gasket: A compressible bond used between two mating metal members to secure a low-impedance path between them.

EMC: Electromagnetic compatibility, the conditions under which all components of a system do not interfere with each other or with their environment.

EMI: Electromagnetic interference (opposite of EMC). Electromagnetic disturbance that degrades performance of electronic equipment.

EMP: Electromagnetic pulse. A broadband, high-intensity, short-duration burst of electromagnetic energy such as might occur as a result of a nuclear explosion.

ESD: Electrostatic discharge. A momentary (and unwanted) discharge of built-up electrical energy, usually from an electrically insulated object to an object with a different electrical potential.

Emission: Unwanted electromagnetic signal emanating from a piece of equipment.

Ferrite: Powdered magnetic material in form of beads, rods, and rings used to absorb EMI on wires and cables.

Field Strength: Radiated voltage or current per meter corresponding to electric or magnetic fields.

Filter: A device to block the flow of EMI while passing the desired signal frequencies.

Grounding: A conductive path to earth designed to eliminate electrical shock by shunting away dangerous currents.

Impulse Noise: A transient electrical disturbance, usually repetitive.

Inductors: Used with capacitors to form tuned circuits to filter out specific signal frequencies.

Magnetic Field: A radiated wave's current gradient, expressed in amperes per meter (A/m).

Multilayer Planar Array: Multi-layer ceramic EMI filter device housed in a connector. The most widely applied type of EMI filter.

Narrowband: EMI Interference whose emission bandwidth is less than the bandwidth of the EMI measuring receiver or spectrum analyzer.

Power Conditioning: Reduction of EMI pollution on power mains by inserting filters, isolators, regulators, or an uninterruptible power supply (UPS).

Radiated Interference: EMI or noise transmitted from any electrical system, from power-lines to mobile telephones.

Radio Frequency Interference (RFI): A special class of electromagnetic interference in which radio frequency transmissions cause unintentional problems in equipment operation.

Reflection Loss: Shielding effectiveness due to energy reflection from impedance mismatch between incident field and metal barrier.

Roll-Off: The frequency in an attenuation curve at which a filter begins to reduce the quality or magnitude of an electrical signal.

Shielding Effectiveness (SE): The ratio of field strengths (absorption and reflection losses) before and after installing a shield.

Dimensions in inches (millimeters) and are subject to change without notice.



Introduction to Filter Connectors EMI/EMP Glossary • RoHS Compliance Preference for Domestic Specialty Metals Statement

Shot Noise: The noise caused by random fluctuations in the motion of charge carriers such as electrons in a conductor.

Skin Depth: The calculated metal layer thickness through which some 63 percent of the surface current flows.

Surge: A sudden voltage increase on the power mains.

TEMPEST: Transient Electromagnetic Pulse Surveillance Technology.

Transfer Impedance (Z_t): The quality of cable shield performance calculated by the ratio of the coupled voltage to the surface current, in ohms per meter (Ω/m).





Transient: A short-duration voltage surge due to a lightning strike or other dynamic event.

UPS: Uninterruptible power supply.

Waveform: For lightning events, measure of electrical transient exposure level and surge severity.

Glenair Statement on RoHS Compliance

European Union Directive 2002/95/EC on Restriction of the use of certain Hazardous Substances ("RoHS") states that certain types of OEM equipment (primarily consumer electronic products such as personal computers) shall not contain lead, mercury, cadmium, hexavalent chromium, PBB's or PBDE's. For the record, Glenair does not produce any OEM products of this type. Furthermore, our interconnect components are either free of the substances RoHS controls, or specifically intended for use in military-aerospace applications that are exempt. Accordingly, Glenair will continue to offer cadmium and chromate finishes in accordance with DoD and aerospace specifications and as required by these customers. Makers of consumer products should refer to RoHS guidelines to ensure interconnect components are correctly specified when used in in RoHS regulated electronic equipment. Consumer product manufacturers may also refer to the following table to ensure any products they may specify from this catalog are equipped with RoHS compliant materials and finishes. Going forward, Glenair will gladly employ substitutes to current military-aerospace materials and finishes as they are proven reliable and as military standards permit.

Connector and Backshell Plating: RoHS Compliance		
Plating Type	RoHS Compliance	Notes
Cadmium with yellow or olive drab chromate conversion coating over electroless nickel	No	Electroless nickel is the preferred alternate.
Electroless nickel		First choice for RoHS compliance. Good corrosion resistance, excellent conductivity, M83513 approved, always in stock.
Stainless steel shell, passivated		Higher cost but unsurpassed corrosion resistance, not conductive enough for typical EMI needs. Build-to-order.
Gold over aluminum		Low volume, higher cost, excellent conductivity. Build-to-order.
Ni-PTFE 1000 Hour Grey™ Nickel Fluorocarbon Polymer		Conductive, CAD-Free, 1000 hr. salt spray plating offers outstanding corrosion protection. MIL-DTL-38999 Rev. L
Chem film	No	Electroless nickel is the preferred alternate.

Preference for Domestic Specialty Metals Statement

For parts we make and sell, we comply with the Preference for Domestic Specialty Metals requirements (as modified by Alternate 1, Deviation 20008-00002) that, additionally, are required to meet US Military Specifications, Federal Specifications, or ASTM (or other industry) Specifications. Vendors certify (and are audited) to adherence with these requirements with each purchase order fulfilled. Glenair parts are in compliance with DFARS 252.225-7014, Alternate 1, Deviation 20008-00002, "Preference for Domestic Specialty Metals."

Dimensions in inches (millimeters) and are subject to change without notice.

© 2013 Glenair, Inc.

U.S. CAGE Code 06324

Printed in U.S.A.

GLENAIR, INC. • 1211 AIR WAY • GLENDALE, CA 91201-2497 • 818-247-6000 • FAX 818-500-9912
www.glenair.com M-21 E-Mail: sales@glenair.com

Glenair Diode Burn-In Services: Fast, Reliable and Comprehensive

In addition to complete system design for EMI/RFI filtering applications and transient over-voltage suppression, Glenair offers in-house high temperature reverse bias (HTRB) diode burn-in services—a screening process designed to ensure Transient Voltage Suppression diode reliability. The reliability of TVS devices is of extreme importance due to the mission-critical role TVS protected electronic equipment plays in aerospace, communications, command and control systems. Failure of a diode is generally attributed to a physical defect in the part. Diode failure modes can include thermal fatigue, contact migration and other factors which can contribute to a short-circuit mode. Industry-standard qualification tests have been developed with stress levels matched to application requirements. The HTRB

test is used to monitor off-state leakage currents to reveal any failure modes prior to final assembly. In general, semiconductor manufacturers can take weeks to deliver tested diodes, whereas Glenair currently takes only days. Our test lab has the capabilities to test surface mount or leaded diodes. Leakage current is monitored throughout the burn-in process. Other labs may just take readings only before and after cycling, potentially missing weak diodes that could fail in the field. Glenair takes and records multiple reading throughout the burn-in process to ensure highest reliability of HTRB services. For this reason, you can count on Glenair for unparalleled diode reliability testing.

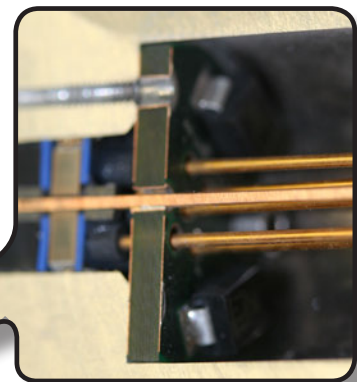
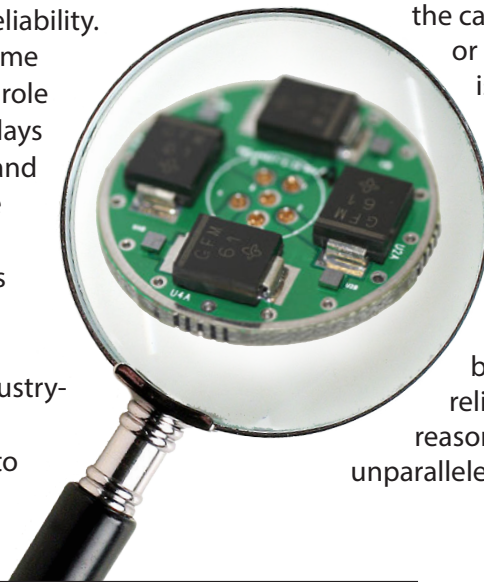

Glenair's state-of-the-art diode burn in process tests leaded and surface mount diodes with leakage current monitored throughout the entire test procedure, ensuring field reliability.

Dimensions in inches (millimeters) and are subject to change without notice.



Compliance Matrix for D38999 Series III Type Filter Connectors

MIL-DTL-38999, Table Xii, Group 2	Paragraph MIL-DTL-38999		3 Samples	
	TEST OR INSPECTION	REQUIREMENT	TEST METHOD	TEST REQUIRED?
Visual and Mechanical Inspection	3.1, 3.3, 3.4, 3.5, 3.52 and 3.53	4.5.1	YES	STANDARD TEST
Gauge Location	3.22	4.5.18	NO	NOT REQUIRED. UUT HAS NON-REMOVABLE CONTACTS
Gauge Retention	3.23	4.5.19	NO	NOT REQUIRED. UUT HAS NON-REMOVABLE CONTACTS
Maintenance Aging	3.6	4.5.2	NO	NOT REQUIRED. UUT HAS NON-REMOVABLE CONTACTS
Contact Retention	3.24	4.5.20.1	NO	NOT REQUIRED. UUT HAS NON-REMOVABLE CONTACTS
Altitude-low temperature	3.25	4.5.21	YES	OC22756-0616284 Altitude Low Temperature (247-245)
Insulation resistance at ambient temperature	N/A	N/A	YES	OC22756-0616284 Altitude Low Temperature (247-245)
Dielectric withstanding voltage at sea level	N/A	N/A	YES	OC22756-0616284 Altitude Low Temperature (247-245)
Capacitance between contacts	N/A	N/A	YES	CAPACITANCE BETWEEN CONTACTS - BEFORE VIBRATION (247-245)
				CAPACITANCE BETWEEN CONTACT - AFTER VIBRATION (247-245)
Capacitance matching	N/A	N/A	YES	CAPACITANCE MATCHING - BEFORE VIBRATION (247-245)
				CAPACITANCE MATCHING - AFTER VIBRATION (247-245)
Insertion loss at minimum temperature	N/A	N/A	YES	INSERTION LOSS AT MIN TEMPERATURE (247-245)
Insertion loss at maximum temperature	N/A	N/A	YES	INSERTION LOSS AT MAX TEMPERATURE (247-245)
Insertion loss for feed thru contacts	N/A	N/A	YES	INSERTION LOSS AT ROOM TEMPERATURE (247-245)
Cross talk isolation	N/A	N/A	YES	CROSSTALK ISOLATION (247-245)
Temperature Shock (380 Cycles)	#N/A	#N/A	YES	380 CYCLES THERMAL SHOCK (247-245)
Air Leakage	N/A	N/A	YES	OC22817-0716312 Air Leakage (247-245)
Functional Test - Ground contact resistance to connector shell	N/A	N/A	NO	NOT REQUIRED. UUT DOES NOT HAVE GROUND CONTACTS.
Functional Test - Contact capacitance to ground	N/A	N/A	YES	380 CYCLES THERMAL SHOCK (247-245)
Functional Test - Dielectric withstanding voltage at sea level	N/A	N/A	YES	380 CYCLES THERMAL SHOCK (247-245)
Functional Test - Insulation resistance	N/A	N/A	YES	380 CYCLES THERMAL SHOCK (247-245)
Coupling Torque	3.11	4.5.7	YES	OC21361-0915309 Coupling Torque (247-245)
Insulation Resistance at elevated temperature	N/A	N/A	YES	Insulation Resistance at Temp (247-245)
Dielectric withstanding voltage at altitude	N/A	N/A	YES	OC21363-0915311 DWV at Altitude (247-245)
Dielectric withstanding voltage at sea level	N/A	N/A	YES	OC21363-0915311 DWV at Altitude (247-245)
Durability	3.12	4.5.8	YES	OC21364-0915312 Durability (247-245)
Accessory thread strength	3.26	4.5.22	NO	NOT REQUIRED. UUT DOES NOT HAVE ACCESSORY THREADS.
Vibration	3.27	4.5.23	YES	OC22773-0616282B Sine Vibration (247-245)
				OC21365-0915313 Random Vibration at Temp (247-245)
Shock	3.28	4.5.24.1	YES	OC21362-0915310 Shock (247-245)
Functional Test - Ground contact resistance to connector shell	N/A	N/A	NO	NOT REQUIRED. UUT DOES NOT HAVE GROUND CONTACTS.
Functional Test - Contact capacitance to ground	N/A	N/A	YES	OC21362-0915310 Shock (247-245)
Functional Test - Dielectric withstanding voltage at sea level	N/A	N/A	YES	OC21362-0915310 Shock (247-245)
Functional Test - Insulation resistance	N/A	N/A	YES	OC21362-0915310 Shock (247-245)
Shell-to-shell conductivity	3.29	4.5.25	YES	OC22635-0316173 Shell-to-Shell Conductivity (247-245)
High temperature exposure	3.38.2	4.5.34.2	YES	High Temperature Exposure (247-245)

Dimensions in inches (millimeters) and are subject to change without notice.

Compliance Matrix for D38999 Series III Type Filter Connectors



Humidity	3.30	4.5.26	YES	OC21366-0915314 Humidity (247-245)
Insulation resistance at ambient temperature	N/A	N/A	YES	OC21366-0915314 Humidity (247-245)
Dielectric withstanding voltage at sea level	N/A	N/A	YES	OC21366-0915314 Humidity (247-245)
Functional Test - Ground contact resistance to connector shell	N/A	N/A	NO	NOT REQUIRED. UUT DOES NOT HAVE GROUND CONTACTS.
Functional Test - Contact capacitance to ground	N/A	N/A	YES	OC21366-0915314 Humidity (247-245)
Functional Test - Dielectric withstanding voltage at sea level	N/A	N/A	YES	OC21366-0915314 Humidity (247-245)
Functional Test - Insulation resistance	N/A	N/A	YES	OC21366-0915314 Humidity (247-245)
Contact retention	3.24	4.5.20.1	NO	NOT REQUIRED. UUT HAS NON-REMOVABLE CONTACTS
Post test examination	3.52 and 3.53	4.5.49	YES	STANDARD TEST

MIL-DTL-38999, Table Xii, Group 5	Paragraph MIL-DTL-38999		3 Samples	
TEST OR INSPECTION	REQUIREMENT	TEST METHOD	TEST REQUIRED?	TEST REPORT
Visual and Mechanical Inspection	3.1, 3.3, 3.4, 3.5, 3.52 and 3.53	4.5.1	YES	OC22772-0616281A Fluid Immersion (247-245)
Ozone exposure	3.33	4.5.29	NO	NOT REQUIRED. UUT WILL NOT BE EXPOSED TO OZONE.
Insulation resistance at ambient temperature	N/A	N/A	YES	OC22772-0616281A Fluid Immersion (247-245)
Dielectric withstanding voltage at sea level	N/A	N/A	YES	OC22772-0616281A Fluid Immersion (247-245)
Fluid immersion	3.34	4.5.30	YES	OC22772-0616281A Fluid Immersion (247-245)
Dielectric withstanding voltage at sea level	N/A	N/A	YES	OC22772-0616281A Fluid Immersion (247-245)
Coupling torque	3.11	4.5.7	YES	OC22772-0616281A Fluid Immersion (247-245)
Functional Test - Ground contact resistance to connector shell	N/A	N/A	NO	NOT REQUIRED. UUT DOES NOT HAVE GROUND CONTACTS.
Functional Test - Contact capacitance to ground	N/A	N/A	YES	OC22772-0616281A Fluid Immersion (247-245)
Functional Test - Dielectric withstanding voltage at sea level	N/A	N/A	YES	OC22772-0616281A Fluid Immersion (247-245)
Functional Test - Insulation resistance	N/A	N/A	YES	OC22772-0616281A Fluid Immersion (247-245)
Post test examination	3.52 and 3.53	4.5.49	YES	OC22772-0616281A Fluid Immersion (247-245)

MIL-DTL-38999, Table Xii, Group 9	Paragraph MIL-DTL-38999		3 Samples	
TEST OR INSPECTION	REQUIREMENT	TEST METHOD	TEST REQUIRED?	TEST REPORT
Visual and Mechanical Inspection	3.1, 3.3, 3.4, 3.5, 3.52 and 3.53	4.5.1	YES	OC22865-0716347A Salt Spray (247-245)
Shock (high impact)	3.28	4.5.24.2	NO	OC21209-0915355 Hi-Impact Shock (247-463)
Dielectric withstanding voltage at sea level	N/A	N/A	YES	OC22865-0716347A Salt Spray (247-245)
Electrolytic erosion	3.39	4.5.35	YES	OC22865-0716347A Salt Spray (247-245)
Shell-to-shell conductivity	3.29	4.5.25	YES	OC22865-0716347A Salt Spray (247-245)
Temperature cycling	N/A	N/A	NO	NOT REQUIRED.
Salt spray (corrosion)	3.17	4.5.13.2	YES	OC22865-0716347A Salt Spray (247-245)
Functional Test - Ground contact resistance to connector shell	N/A	N/A	NO	NOT REQUIRED. UUT DOES NOT HAVE GROUND CONTACTS.
Functional Test - Contact capacitance to ground	N/A	N/A	YES	OC22865-0716347A Salt Spray (247-245)
Functional Test - Dielectric withstanding voltage at sea level	N/A	N/A	YES	OC22865-0716347A Salt Spray (247-245)

Dimensions in inches (millimeters) and are subject to change without notice.



Compliance Matrix for D38999 Series III Type Filter Connectors

Functional Test - Insulation resistance	N/A	N/A	YES	OC22865-0716347A Salt Spray (247-245)
Coupling torque	3.11	4.5.7	YES	OC22865-0716347A Salt Spray (247-245)
Shell-to-shell conductivity	3.29	4.5.25	YES	OC22865-0716347A Salt Spray (247-245)
Coupling pin strength	3.21	4.5.17	NO	NOT REQUIRED. UUT IS A SERIES III TYPE CONNECTOR.
Post test examination	3.52 and 3.53	4.5.49	YES	OC22865-0716347A Salt Spray (247-245)

MIL-DTL-38999, Table Xii, Group 10	Paragraph MIL-DTL-38999		2 Samples	
TEST OR INSPECTION	REQUIREMENT	TEST METHOD	TEST REQUIRED?	TEST REPORT
Visual and Mechanical Inspection	3.1, 3.3, 3.4, 3.5, 3.52 and 3.53	4.5.1	NO	NOT REQUIRED. UUT IS NOT A FIREWALL CLASS CONNECTOR.
Firewall	3.40	4.5.36	NO	NOT REQUIRED. UUT IS NOT A FIREWALL CLASS CONNECTOR.
Post test examination	3.52 and 3.53	4.5.49	NO	NOT REQUIRED. UUT IS NOT A FIREWALL CLASS CONNECTOR.

MIL-DTL-38999, Table Xii, Group 11	Paragraph MIL-DTL-38999		3 Samples	
TEST OR INSPECTION	REQUIREMENT	TEST METHOD	TEST REQUIRED?	TEST REPORT
Visual and Mechanical Inspection	3.1, 3.3, 3.4, 3.5, 3.52 and 3.53	4.5.1	YES	OC22641-0516246 Ice & Dust (247-245)
Ice resistance	3.44	4.5.40	YES	OC22641-0516246 Ice & Dust (247-245)
Dust (fine sand)	3.45	4.5.41	YES	OC22641-0516246 Ice & Dust (247-245)
Impact (classes J and M)	3.49	4.5.45	NO	NOT REQUIRED. UUT IS NOT A CLASS J OR M CONNECTOR.
Functional Test - Ground contact resistance to connector shell	N/A	N/A	NO	NOT REQUIRED. UUT DOES NOT HAVE GROUND CONTACTS.
Functional Test - Contact capacitance to ground	N/A	N/A	YES	OC22641-0516246 Ice & Dust (247-245)
Functional Test - Dielectric withstanding voltage at sea level	N/A	N/A	YES	OC22641-0516246 Ice & Dust (247-245)
Functional Test - Insulation resistance	N/A	N/A	YES	OC22641-0516246 Ice & Dust (247-245)
Post test examination	3.52 and 3.53	4.5.49	YES	OC22641-0516246 Ice & Dust (247-245)

MIL-DTL-38999, Table Xii, Group 13	Paragraph MIL-DTL-38999		2 Samples	
TEST OR INSPECTION	REQUIREMENT	TEST METHOD	TEST REQUIRED?	TEST REPORT
Visual and Mechanical Inspection	3.1, 3.3, 3.4, 3.5, 3.52 and 3.53	4.5.1	NO	NOT REQUIRED. UUT IS NOT A CLASS J OR M CONNECTOR.
Hydrolytic stability (classes J and M)	3.47	4.5.43	NO	NOT REQUIRED. UUT IS NOT A CLASS J OR M CONNECTOR.
Post test examination	3.52 and 3.53	4.5.49	NO	NOT REQUIRED. UUT IS NOT A CLASS J OR M CONNECTOR.

MIL-DTL-38999, Table Xii, Group 14	Paragraph MIL-DTL-38999		2 Samples	
TEST OR INSPECTION	REQUIREMENT	TEST METHOD	TEST REQUIRED?	TEST REPORT
Visual and Mechanical Inspection	3.1, 3.3, 3.4, 3.5, 3.52 and 3.53	4.5.1	NO	NOT REQUIRED. UUT DOES NOT HAVE ACCESSORY THREADS.
Coupling torque	3.11	4.5.7	NO	NOT REQUIRED. UUT DOES NOT HAVE ACCESSORY THREADS.
Backshell shield braid-to-shell conductivity	3.29.1	4.5.25.1	NO	NOT REQUIRED. UUT DOES NOT HAVE ACCESSORY THREADS.

Dimensions in inches (millimeters) and are subject to change without notice.

Compliance Matrix for D38999 Series III Type Filter Connectors

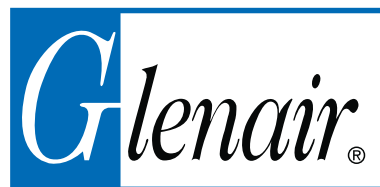

Resistance to indirect lightning strike	3.51	4.5.47	NO	NOT REQUIRED. UUT DOES NOT HAVE ACCESSORY THREADS.
Backshell shield braid-to-shell conductivity	3.29.1	4.5.25.1	NO	NOT REQUIRED. UUT DOES NOT HAVE ACCESSORY THREADS.
Coupling torque	3.11	4.5.7	NO	NOT REQUIRED. UUT DOES NOT HAVE ACCESSORY THREADS.
Insulation resistance at ambient temperature	N/A	N/A	NO	NOT REQUIRED. UUT DOES NOT HAVE ACCESSORY THREADS.
Dielectric withstanding voltage at sea level	N/A	N/A	NO	NOT REQUIRED. UUT DOES NOT HAVE ACCESSORY THREADS.
Post test examination	3.52 and 3.53	4.5.49	NO	NOT REQUIRED. UUT DOES NOT HAVE ACCESSORY THREADS.

Lightning Transient Test Group	Paragraph MIL-DTL-38999		2 Samples	
TEST OR INSPECTION	REQUIREMENT	TEST METHOD	TEST REQUIRED?	TEST REPORT
Lightning transient test	N/A	N/A	YES	TR056503 Lightning (247-245)
Functional Test - Ground contact resistance to connector shell	N/A	N/A	NO	NOT REQUIRED. UUT DOES NOT HAVE GROUND CONTACTS.
Functional Test - Contact capacitance to ground	N/A	N/A	YES	TR056503 Lightning (247-245)
Functional Test - Dielectric withstanding voltage at sea level	N/A	N/A	YES	TR056503 Lightning (247-245)
Functional Test - Insulation resistance	N/A	N/A	YES	TR056503 Lightning (247-245)

Rapid Decompression And Explosion Proofness Test Group	Paragraph MIL-DTL-38999		2 Samples	
TEST OR INSPECTION	REQUIREMENT	TEST METHOD	TEST REQUIRED?	TEST REPORT
Rapid decompression	N/A	N/A	YES	OC22757-0616266 Rapid Decompression (247-245)
Explosion Proofness	N/A	N/A	NO	NOT REQUIRED. UUT DOES NOT HAVE ACTIVE COMPONENTS.
Functional Test - Ground contact resistance to connector shell	N/A	N/A	NO	NOT REQUIRED. UUT DOES NOT HAVE GROUND CONTACTS.
Functional Test - Contact capacitance to ground	N/A	N/A	YES	OC22757-0616266 Rapid Decompression (247-245)
Functional Test - Dielectric withstanding voltage at sea level	N/A	N/A	YES	OC22757-0616266 Rapid Decompression (247-245)
Functional Test - Insulation resistance	N/A	N/A	YES	OC22757-0616266 Rapid Decompression (247-245)

Filter Life Test Group	Paragraph MIL-DTL-38999		2 Samples	
TEST OR INSPECTION	REQUIREMENT	TEST METHOD	TEST REQUIRED?	TEST REPORT
Filter life	N/A	N/A	YES	1000 Hour Life Test (247-075)
Functional Test - Ground contact resistance to connector shell	N/A	N/A	NO	NOT REQUIRED. UUT DOES NOT HAVE GROUND CONTACTS.
Functional Test - Contact capacitance to ground	N/A	N/A	YES	1000 Hour Life Test (247-075)
Functional Test - Dielectric withstanding voltage at sea level	N/A	N/A	YES	1000 Hour Life Test (247-075)
Functional Test - Insulation resistance	N/A	N/A	YES	1000 Hour Life Test (247-075)

Dimensions in inches (millimeters) and are subject to change without notice.



Series 240 Filter Connectors Part Number Index

Part Number	Page
103-026	L-12
103-027	L-12
103-031	L-13
103-051	L-13
107-098	L-14
107-099	L-15
179-045	L-11
240-021	E-2
240-030	D-7
240-031	D-9
240-032	D-14
240-033	D-16
240-034	D-18
240-051	E-10
240-066	E-6
240-075	D-23
240-076	D-25
240-077	D-27
240-078	D-29
240-083	E-12
240-264A	B-68
240-264J	B-66
240-264W	B-64
240-288A	B-112
240-288J	B-110
240-288W	B-108
240-381A	B-14
240-381J	B-10
240-381R	B-8
240-381S	B-12
240-381W	B-6
240-382A	B-24
240-382J	B-22
240-382W	B-20

Part Number	Page
240-383A	B-46
240-383D	B-42
240-383E	B-44
240-383J	B-36
240-383P	B-30
240-383Q	B-32
240-383R	B-38
240-383S	B-40
240-383W	B-34
240-384J	B-52
240-384R	B-58
240-384S	B-54
240-384W	B-56
240-515A	B-104
240-515J	B-100
240-515W	B-102
240-601	H-2
240-602	H-4
240-603	H-6
240-790-028	G-2
240-790-029	G-8
240-790-043	G-14
240-790-044	G-20
240-790-069	G-38
240-790-070	G-44
240-790-071	G-50
240-790-072	G-56
240-800	C-22
240-801	C-8
240-801-AA	C-12
240-804	C-14
240-805	C-16
240-805-AA	C-20
240-837A	B-74

Part Number	Page
240-837J	B-76
240-837W	B-78
240-838A	B-80
240-838J	B-82
240-838W	B-84
240-970J	F-4
240-970W	F-2
240-ITSJ	B-92
240-ITSW	B-94
242-383A	J-2
242-383P	J-4
242-383S	J-6
245-805	K-1
2470-1048	D-36
2470-1112	E-14
247-379	D-31
249-001	L-2
249-002	L-4
249-003	L-6
249-005	L-8
249-006	L-9
249-033	L-10
249-051	L-10
249-EMITS-DSUB	E-15
249-EMITS-MICRO	D-37
601-005	L-17
601-024	L-19
601-040	L-17
601-049	L-17
601-060	L-19
601-064	L-19
601-100	L-16
601-101	L-18

Dimensions in inches (millimeters) and are subject to change without notice.

WHY
CHOOSE

Glenair?



Plenty of Raw Materials!



Outstanding
Customer Service!



Abundant Machining Capacity!



In-House Assembly!



Huge "Same-Day" Inventory!

Glenair®

Glenair, Inc.
1211 Air Way
Glendale, CA
91201-2497
818-247-6000
sales@glenair.com
www.glenair.com



Out of This World
**INTERCONNECT
SOLUTIONS**

Glenair, Inc.

1211 Air Way • Glendale, California • 91201-2497
Telephone: 818-247-6000 • Fax: 818-500-9912 • sales@glenair.com
www.glenair.com

**Glenair Power
Products Group**

860 N. Main Street Extension
Wallingford, CT
06492

Telephone:
203-741-1115
Facsimile:
203-741-0053
sales@glenair.com

Glenair UK Ltd

40 Lower Oakham Way
Oakham Business Park
P.O. Box 37, Mansfield
Notts, NG18 5BY England

Telephone:
+44-1623-638100
Facsimile:
+44-1623-638111
sales@glenair.co.uk

Glenair Microway Systems

7000 North Lawndale Avenue
Lincolnwood, IL
60712

Telephone:
847-679-8833
Facsimile:
847-679-8849

Glenair Nordic AB

Gustav III : S Boulevard 46
S - 169 27 Solna
Sweden

Telephone:
+46-8-50550000
Facsimile:
+46-8-50550001
sales@glenair.se

Glenair Electric GmbH

Schaberweg 28
61348 Bad Homburg
Germany

Telephone:
06172 / 68 16 0
Facsimile:
06172 / 68 16 90
germany@glenair.com

Glenair Iberica

C/ La Vega, 16
45612 Velada
Spain

Telephone:
+34-925-89-29-88
Facsimile:
+34-925-89-29-87
sales@glenair.es

Glenair Italia S.p.A.

Via Del Lavoro, 7
40057 Quarto Inferiore –
Granarolo dell'Emilia
Bologna, Italy

Telephone:
+39-051-782811
Facsimile:
+39-051-782259
info@glenair.it

Glenair France SARL

7, Avenue Parmentier
Immeuble Central Parc #2
31200 Toulouse
France

Telephone:
+33-5-34-40-97-40
Facsimile:
+33-5-61-47-86-10
sales@glenair.fr

