

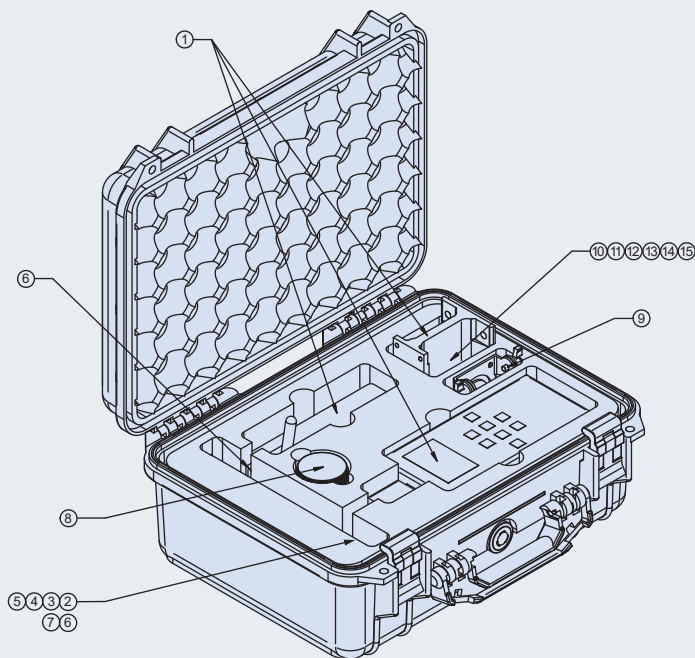

## Calibration Kits and Accessories



### 601-200 Calibration Kit For All Banding Tools

**The 601-200 Calibration Kit** includes:

1. 601-200-3 calibration device
2. Fifty 601-203 Micro test bands
3. Fifty 601-202 Standard test bands
4. Fifty 601-217 Nano test bands
5. Fifty 601-224 Slim Standard test bands
6. Fifty 601-227 Micro Slim test bands
7. Fifty 601-230 Micro-Max test bands
8. 601-205 calibration adjustment key
9. Adjustable mounting bracket for meter
10. 601-218 tool adapter for 600-058
11. 601-219 tool adapter for 600-067
12. 601-220 tool adapter for 600-061, 600-068
13. 601-223 tool adapter for 601-109, 601-110, 601-100, 601-106
14. 601-225 tool adapter for 601-101, 601-107, 601-122, 601-123, 601-129, 601-130
15. 601-226 Tool adapter for 601-108 and 601-118

Range of the calibration device is 0 to 500 lbs, and accuracy is calibrated to  $\pm 1$  lbs. at factory. Digital readout in .1 lb. increments. Meter supplied with RS-232 serial communication port. Serial/USB adapter cable included.

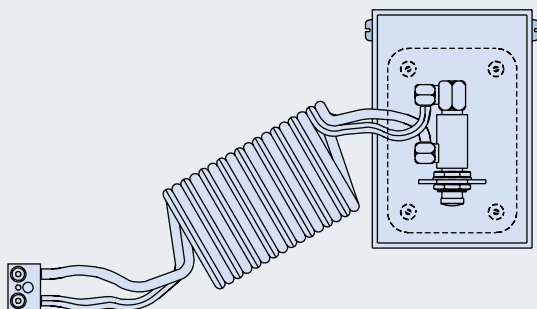

### 601-400 Foot Pedal Control for 601-106, 601-107, 601-110 and 601-118 Pneumatic Banding Tools

**The 601-400 Foot Pedal Control** frees both hands to help assure more accurate, reliable and faster shield terminations.