

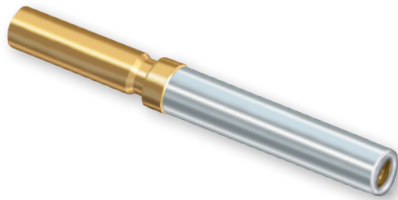

850-336-20-22
 M39029/56-351 Type
 Size 20 Socket Contact with Size 22 Crimp Barrel

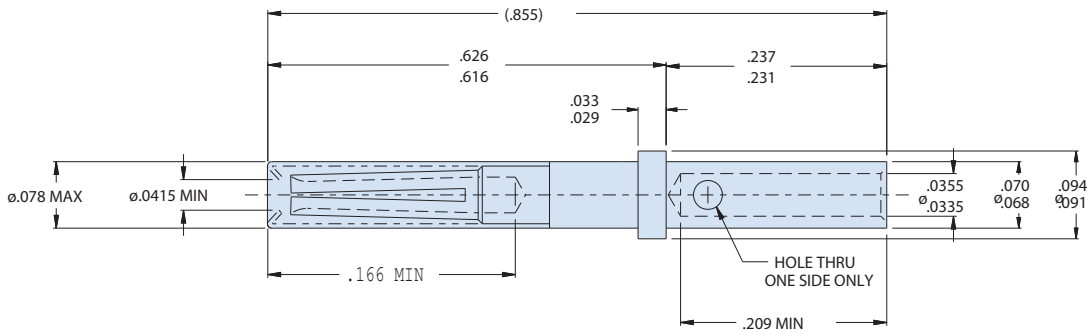

Mating End Size	Glenair Part Number	Wire Size
20	850-336-20	-22



Material and Finish

Contact body: Copper alloy / gold plated IAW ASTM B 488, Type II, code C, .000050
 Min thick, over nickel IAW SAE AMS-QQ-N-290, class 2, .000030 to .000150 thick.
 Hood: 305 cres, passivated

Crimp Tooling Data

Basic crimp tool: M22520/2-01
 Positioner: M22520/2-10

Notes

These contacts shall meet or exceed the applicable requirements specified in AS39029/56-351 except for 22AWG-28AWG crimp barrel.