

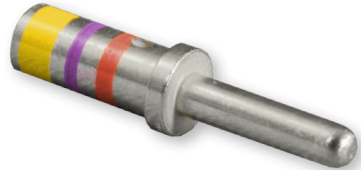

**Thermocouple Pin Contact to Fit D38999 Series I, II, III and IV and M24308 Connectors**

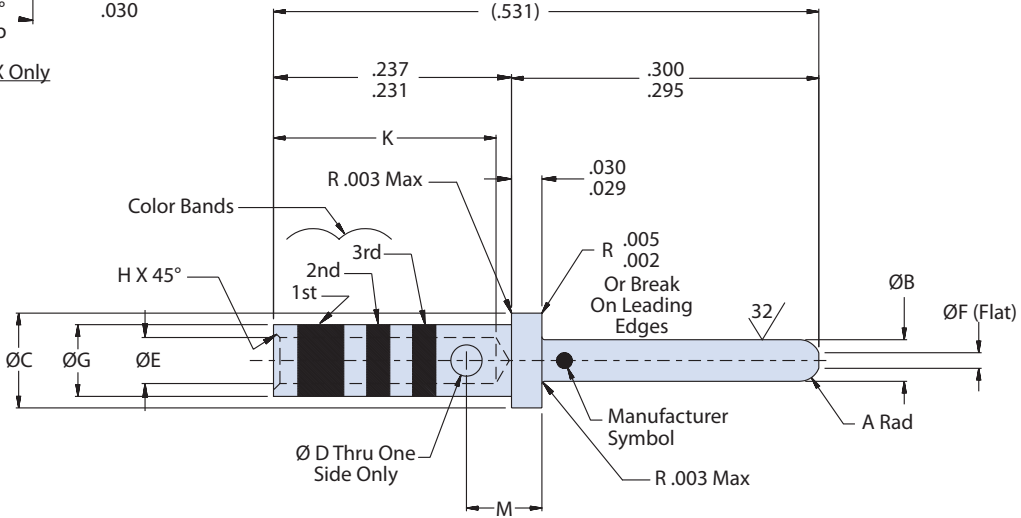

| Mating End Size | Wire Accomodation | Military Part Number | Glenair Part Number |
|-----------------|-------------------|----------------------|---------------------|
| 22              | 22-28 AWG         | M39029/87-470        | 850-023-22-470      |
| 22              | 22-28 AWG         | M39029/87-471        | 850-023-22-471      |
| 22              | 22-28 AWG         | M39029/87-472        | 850-023-22-472      |
| 22              | 22-28 AWG         | M39029/87-473        | 850-023-22-473      |
| 20              | 20-24 AWG         | M39029/87-474        | 850-023-20-474      |
| 20              | 20-24 AWG         | M39029/87-475        | 850-023-20-475      |
| 20              | 20-24 AWG         | M39029/87-476        | 850-023-20-476      |
| 20              | 20-24 AWG         | M39029/87-477        | 850-023-20-477      |
| 16              | 16-20 AWG         | M39029/87-478        | 850-023-16-478      |
| 16              | 16-20 AWG         | M39029/87-479        | 850-023-16-479      |
| 16              | 16-20 AWG         | M39029/87-480        | 850-023-16-480      |
| 16              | 16-20 AWG         | M39029/87-481        | 850-023-16-481      |

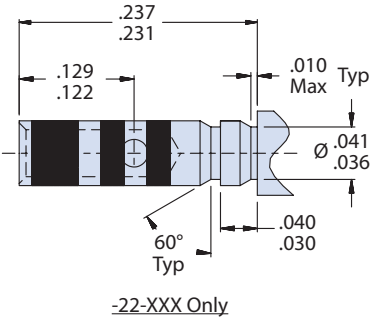

850-023  
AS39029/87 Type  
Thermocouple Pin Contact



Special Purpose

TABLE I: CONTACT DIMENSIONS

| Size | Glenair Part Number | Military Number | A (rad)      | ø B Min.       | ø C          | ø D          | ø E            | ø F          | ø G          | H            |
|------|---------------------|-----------------|--------------|----------------|--------------|--------------|----------------|--------------|--------------|--------------|
| 22   | 850-023-22-470      | M39029/87-470   | .020<br>.010 | .0305<br>.0295 | .062<br>.060 | .022<br>.018 | .0355<br>.0335 | .011<br>max  | .048<br>.046 | .005<br>.003 |
|      | 850-023-22-471      | M39029/87-471   |              |                |              |              |                |              |              |              |
|      | 850-023-22-472      | M39029/87-472   |              |                |              |              |                |              |              |              |
|      | 850-023-22-473      | M39029/87-473   |              |                |              |              |                |              |              |              |
| 20   | 850-023-20-474      | M39029/87-474   | .025<br>.015 | .041<br>.039   | .094<br>.091 | .032<br>.026 | .048<br>.046   | .015<br>max  | .070<br>.068 | .010<br>.005 |
|      | 850-023-20-475      | M39029/87-475   |              |                |              |              |                |              |              |              |
|      | 850-023-20-476      | M39029/87-476   |              |                |              |              |                |              |              |              |
|      | 850-023-20-477      | M39029/87-477   |              |                |              |              |                |              |              |              |
| 16   | 850-023-16-478      | M39029/87-478   | .025<br>.020 | .0635<br>.0615 | .130<br>.127 | .042<br>.036 | .068<br>.066   | .030<br>.011 | .103<br>.101 | .010<br>.005 |
|      | 850-023-16-479      | M39029/87-479   |              |                |              |              |                |              |              |              |
|      | 850-023-16-480      | M39029/87-480   |              |                |              |              |                |              |              |              |
|      | 850-023-16-481      | M39029/87-481   |              |                |              |              |                |              |              |              |

TABLE I (Continued): CONTACT DIMENSIONS

| Size | Glenair Part Number | Military Number | K            | M            | Color Bands |        |        | Material | Plating        |
|------|---------------------|-----------------|--------------|--------------|-------------|--------|--------|----------|----------------|
|      |                     |                 |              |              | 1st         | 2nd    | 3rd    |          |                |
| 22   | 850-023-22-470      | M39029/87-470   | .157<br>.141 | -            | Yellow      | Violet | Black  | JN       | None           |
|      | 850-023-22-471      | M39029/87-471   |              |              | Yellow      | Violet | Brown  | KN       | None           |
|      | 850-023-22-472      | M39029/87-472   |              |              | Yellow      | Violet | Red    | KP       | None           |
|      | 850-023-22-473      | M39029/87-473   |              |              | Yellow      | Violet | Orange | JP       | Cadmium Plate* |
| 20   | 850-023-20-474      | M39029/87-474   | .229<br>.209 | .078<br>.072 | Yellow      | Violet | Yellow | JN       | None           |
|      | 850-023-20-475      | M39029/87-475   |              |              | Yellow      | Violet | Green  | KN       | None           |
|      | 850-023-20-476      | M39029/87-476   |              |              | Yellow      | Violet | Blue   | KP       | None           |
|      | 850-023-20-477      | M39029/87-477   |              |              | Yellow      | Violet | Violet | JP       | Cadmium Plate* |
| 16   | 850-023-16-478      | M39029/87-478   | .229<br>.209 | .088<br>.082 | Yellow      | Violet | Gray   | JN       | None           |
|      | 850-023-16-479      | M39029/87-479   |              |              | Yellow      | Violet | White  | KN       | None           |
|      | 850-023-16-480      | M39029/87-480   |              |              | Yellow      | Gray   | Black  | KP       | None           |
|      | 850-023-16-481      | M39029/87-481   |              |              | Yellow      | Gray   | Brown  | JP       | Cadmium Plate* |

Per AS39029 spec, the composition designations have been changed as listed below:  
**JN** =Type J negative (formerly constantan)    **KP** =Type K positive (formerly chromel)  
**KN** =Type K negative (formerly alumel)        **JP** =Type J positive (formerly iron)

\*Chromate Clear Coat.

TABLE II: TOOL COMPATIBILITY

| Size | Glenair Part Number | Military Number | AWG Handling   | Crimp Tool                                | Positioner   | Insertion Tool              | Extraction Tool             |
|------|---------------------|-----------------|----------------|---|--|-----------------------------|-----------------------------|
| 22   | 850-023-22-470      | M39029/87-470   | 22, 24, 26, 28 | M22520/2-01<br>M22520/7-01                | M22520/2-09<br>M22520/7-07                         | M81969/14-01<br>M81969/8-01 | M81969/14-01<br>M81969/8-02 |
|      | 850-023-22-471      | M39029/87-471   |                |   |  |                             |                             |
|      | 850-023-22-472      | M39029/87-472   |                |   |  |                             |                             |
|      | 850-023-22-473      | M39029/87-473   |                |   |  |                             |                             |
| 20   | 850-023-20-474      | M39029/87-474   | 20, 22, 24     | M22520/7-01<br>M22520/2-01<br>M22520/1-01 | M22520/7-08<br>M22520/2-10<br>M22520/1-04<br>(Red) | M81969/8-05<br>M81969/14-02 | M81969/8-06<br>M81969/14-02 |
|      | 850-023-20-475      | M39029/87-475   |                |   |  |                             |                             |
|      | 850-023-20-476      | M39029/87-476   |                |   |  |                             |                             |
|      | 850-023-20-477      | M39029/87-477   |                |   |  |                             |                             |
| 16   | 850-023-16-478      | M39029/87-478   | 16, 18, 20     | M22520/1-01<br>M22520/7-01                | M22520/1-04 (Blue)<br>M22520/7-04                  | M81969/8-07<br>M81969/14-03 | M81969/8-08<br>M81969/14-03 |
|      | 850-023-16-479      | M39029/87-479   |                |   |  |                             |                             |
|      | 850-023-16-480      | M39029/87-480   |                |   |  |                             |                             |
|      | 850-023-16-481      | M39029/87-481   |                |   |  |                             |                             |