

El Ochito® Red HDMI and DisplayPort Product Features

**SUPERFLY
DATALINK** 

*The High-Speed Ultraminiature
Connector for Harsh Environments*



- **Ultra-small size**
- **Shielded Octaxial contacts**
- **Combo arrangement for HDMI 2.0 and DisplayPort 1.2**
- **Up to 10 Gbps per pair**
- **PCB or cable termination**
- **Threaded or Quick-disconnect**
- **Environmentally protected**
- **Aerospace-grade performance**

Cable connectors feature gold-plated crimp contacts, precision insulators, an integral backshell, and machined shells. Cable connectors are available as unassembled kits or ready-to-use factory-terminated cordsets.

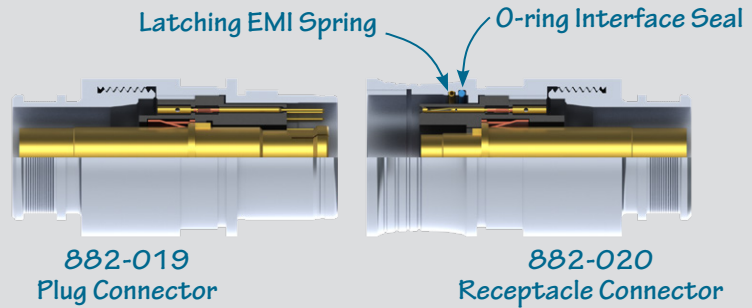

Push-pull SuperFly Datalink receptacle connectors feature a canted coil spring for secure mating and excellent EMI protection while fluorosilicone O-ring provides watertight sealing when mated.

Push-Pull HDMI and DisplayPort Cable Receptacle

